



# European Journal of Educational Research

Volume 11, Issue 2, 621 - 638.

ISSN: 2165-8714

<http://www.eu-jer.com/>

## Psychological Well-Being of School Counsellors Model

**Nur Jannah Bali-Mahomed**   
Universiti Kebangsaan, MALAYSIA

**Ku Suhaila Ku-Johari**   
Universiti Kebangsaan, MALAYSIA

**Mohd Izwan Mahmud**   
Universiti Kebangsaan, MALAYSIA

**Salleh Amat**   
Universiti Kebangsaan, MALAYSIA

**Syazwani Saadon**   
Universiti Kebangsaan, MALAYSIA

*Received: September 15, 2021 • Revised: November 13, 2021 • Accepted: January 1, 2022*

**Abstract:** The school counselor's role is increasingly challenging with various demands of students' problems and the issue of Coronavirus disease (COVID-19) pandemic also affect students' psychosocial and mental well-being. Therefore, school counselors need to equip themselves with high psychological well-being as a self-care factor to deal with burnout, instability, and work stress. This study aims to develop Psychological Well-Being Model among school counsellors. A total of 330 secondary school counsellors from four districts in Selangor were selected as the respondents using the group random sampling method. Data were collected through translated questionnaire instruments, namely Self Compassion Scale, Counselling Self Estimate Inventory, The Assessing Emotions Scale, Spiritual Involvement and Beliefs Scale Revised, and Psychological Well Being-Ryff. Confirmation Factor Analysis (CFA) and Structural Equation Modeling (SEM) show that there is a significant positive relationship between self-compassion, counselling self-efficacy, emotional intelligence, spiritual intelligence, and the school counsellor's psychological well-being. The findings also showed that self-compassion, counselling self-efficacy, emotional and spiritual intelligence affected 76.5% ( $R^2 = 0.765$ ) of variance in psychological well-being. This study is one of the earliest in presenting the school counsellor's psychological well-being model who can contribute to Malaysian education. The implications of this study suggest that the elements of self-compassion, counselling self-efficacy, emotional and spiritual intelligence, and psychological well-being should be applied in the curriculum at the counsellor training level in university so that counsellors have adequate preparation in providing effective services in schools. The Ministry of Education Malaysia, on the other hand, needs to cultivate psychological well-being interventions regularly so that counsellors can always manage various students' issues in schools as well as maintaining psychological well-being in terms of personnel and professionals.

**Keywords:** *Self-compassion, counseling self-efficacy, emotional intelligence, spiritual intelligence, psychological well-being, school counsellors.*

**To cite this article:** Ku-Johari, K. S., Bali-Mahomed, N. J., Mahmud, M. I., Amat, S., & Saadon, S. (2022). Psychological well-being of school counsellors model. *European Journal of Educational Research*, 11(2), 621-638. <https://doi.org/10.12973/eu-jer.11.2.621>

### Introduction

School counsellors are individuals responsible for delivering guidance and counselling services in schools. The counsellor's role becomes increasingly important in the era of national development, especially in producing individuals who have a noble character, high identity, highly knowledgeable and skilled (Johari & Amat, 2019). Therefore, Ministry of Education Malaysia (MoEM) outlines four focuses to be highlighted by the school counsellors, namely students' personal development, students' self-discipline improvement, students' career education as well as students' psychosocial and mental well-being (Ministry of Education, 2012). However, the increase in various recent domestic violence issues, attempted suicide, and child abuse (Jaafar, 2016) has made the counselling profession more challenging. Furthermore, students' problems such as lesbian, gay and bisexual make counsellors' self-efficacy declining (Sanders et al., 2017).

The school counsellor's role becomes complicated during the outbreak of the Coronavirus disease (COVID-19) pandemic. Majumdar et al. (2020) found that the COVID-19 issue affects students' well-being in terms of health, sleep disorders, anxiety, discomfort, and physical symptoms such as headaches, insomnia, and fatigue because of stress. Similarly, Golberstein et al. (2020) also found that mental health care is vital for children and adolescents, and usually,

**\* Corresponding author:**

Ku Suhaila Ku-Johari, Faculty of Education, Universiti Kebangsaan, Selangor, Malaysia. ✉ [suhaila@ukm.edu.my](mailto:suhaila@ukm.edu.my)



this disorder starts from young and, if left untreated, will cause various health problems and adverse social outcomes. According to them, the COVID-19 pandemic exacerbates mental health problems among children and adolescents due to public health issues, social isolation, and economic recession. Economic issues affect unemployment and adults' mental health, which also result in child abuse. In short, pandemic issues have triggered loneliness (Groarke et al., 2020) and mental health problems. Patrick et al. (2020) mentioned that COVID-19 had a detrimental effect on parents and children in the United States, where one of seven parents reported deteriorating behavioural health in their children. All of these scenarios affect the counsellor's career in school. Counsellors are also normal human beings who do not run away from personnel and professionals' pressures. Therefore, school counsellors need to prioritize personal well-being, especially the aspects of psychological well-being, to deliver effective counselling services in schools.

#### *Issues in Professional Counselling Services*

The demand to maintain counsellors' personal well-being is part of their professional responsibility. This coincides with the American Counseling Association, Code of Ethics (American Counseling Association, 2014) which focuses on counsellor's self-care in term of personal well-being. Meanwhile, Mcleod and Mcleod (2014) also focuses on the importance of maintaining counselling well-being, and this is supported by Callender and Lenz (2018), who encourage counsellors to take care of personal welfare and therapeutic effectiveness. However, counsellors are also human beings and face burnout, stress, and negative emotions (Roxas et al., 2019). There are times when counsellors get caught in client suffering, so they need to be aware even of entering into the client's life, but they need to remain present in their own lives (Skovholt & Mathison, 2016). Undeniably, counsellors experience stress when they are doing their best during counselling sessions, especially unbiased, more competent, not judgmental, and cultivate a sense of affection (Friedman, 2017).

Meanwhile, Coaston (2017) found that the burnout scenario among counsellors is due to the lack of ability to approach clients which results to interfere with the counsellor's emotions to focus on an extended period with a client. In addition, the counsellors' workload who undertake work not related to the counselling profession is among the main factors causing burnout, especially fatigue with the hostile work environment, reducing practical work, and inconsistency between expectations of duties and practices of school counsellors (Bardhoshi et al., 2014). Furthermore, instability often occurs when counsellors persistently focus on the client's plight and ignore and reject the counsellor's self-care needs (Lawson et al., 2007). Several previous studies have also discussed burnout problems among those in counselling that can affect their services (Kim & Lambie, 2018; Mullen & Crowe, 2017; Mullen & Gutierrez, 2016).

Furthermore, a recent domestic study found that school counsellors in Sarawak face the risk of burnout (Huat, 2018). Meanwhile, other studies have found that school counsellors' well-being is only at an average score (Kuen, 2015; Reping, 2017). This, gives the impression that school counsellors need to constantly monitor personal well-being and these personal care needs need to be taken seriously so that counsellors can deliver quality services to students in school. This is also emphasized by Arnout and Almoied, (2021) that unwell counsellors are unable to offer quality counselling services to their clients. Accordingly, studies on the psychological well-being of counsellors are appropriate to carry out and some past researchers have found that factors of self-compassion, counselling self-efficacy, emotional intelligence and spiritual intelligence influence psychological well-being. However, there are still few studies that focus all of these factors simultaneously on the school counsellors' psychological well-being. Therefore, the researcher intends to conduct this study to determine the relationship of self-compassion factors, counselling self-efficacy, emotional intelligence, and spiritual intelligence with psychological well-being and examining the contribution of all these factors to the psychological well-being of school counsellors. Researchers also developed a model of school counsellor psychological well-being that matched the data of the study.

#### *Research Objectives*

The objectives of the study are:

- To determine the relationship between self-compassion, counselling self-efficacy, emotional intelligence, spiritual intelligence, and school counsellors' psychological well-being.
- To determine the influence of self-compassion, counselling self-efficacy, emotional intelligence, spiritual intelligence towards school counsellors' psychological well-being.
- To develop psychological well-being model among school counsellors.

### **Literature Review**

#### *Psychological Well-being*

Ryan and Deci (2001) integrate the two perspectives of well-being which are hedonic well-being and eudemonic well-being. Hedonic well-being is related to individual happiness and is determined to achieve pleasure and avoid pain or suffering. Meanwhile, eudemonic well-being focuses on meaning, self-awareness involving human potential and serves as a fully functional individual level. Besides, Keyes et al. (2002) describe subjective well-being (SWB) as the assessment of life in terms of satisfaction and balance between positive and negative effects, while psychological well-

being (PWB) requires a perception of involvement in the existence of life challenges. In short, western researchers argue on a factual theoretical basis and have a broad view of the concept of well-being.

Ryff (1989) psychological well-being highlights a better interpretation of well-being (Ryan & Deci, 2001). Ryff (1989, 1995) describes psychological well-being as an individual free from negative feelings, feeling happy, being positive about oneself and past experiences, and striving to develop one's potential fully. Individuals with high psychological well-being are able to accept themselves and past lives well, function optimally, build positive relationships with other individuals, be loving and friendly (Stephanou & Athanasiadou, 2020). Generally, the component of psychological well-being drives an independent individual to function perfectly, wisely in choosing or creating an environment that suits him and having life goals to achieve and constantly developing potential and self-development.

Ryff (1995) describes well-being as encompassing continuous development throughout life. He presented a psychological well-being model in six dimensions: purpose in life, self-acceptance, environmental mastery, autonomy, personal growth, and positive relationships with others. Several previous studies have further reinforced the role of well-being as an aspect of personal care for the counselling services profession capable of controlling stress and burnout. For example, in his study, Brand (2019) mentions that personal and professional factors can cause stress on counsellors that results in problems such as burnout. Self-care is a way to help burnout. Counsellors need to learn to identify needs and act to maintain emotional, mental, physical, and social health while individual and personal support within themselves can reduce the likelihood of burnout and improve overall health. The study of Fye et al. (2020) shows various dimensions of burnout have been identified as relevant and a priority in focusing on personal care so that school counsellors are exposed to guidance opportunities and can improve advocacy skills and help reduce burnout problems. In addition, several past researchers have also found that psychological well-being also contributes to perceptions of counsellors' well-being (Harris et al., 2013; Merryman et al., 2015).

Meanwhile, previous studies also support that psychological well-being can refine adequate counselling services quality (Augustine & Anuradha, 2015; Purwaningrum et al., 2019). Meanwhile, Augustine and Anuradha (2015) explained that creating the school counsellor's position is one of the new educational efforts in India. He explores insights into school counsellors' psychological well-being by using qualitative research methods as appropriate to the counselling profession. The concept of psychological well-being is explored in detail, and the findings describe a) state of mind including good and balanced behaviour and b) sharp thinking and positive behaviour. Furthermore, Augustine and Anuradha (2015) view well-being as an integrated life in physical, mental, spiritual, social, and psychological development. This can be a useful guide to school counsellors in their careers and can be a practical checklist to ensure their own well-being.

### *Self-Compassion*

Self-compassion refers to an individual who has an open attitude, good treatment of himself, caring, feeling that the negative experiences he went through are part of the experiences of others and have the characteristics of self-concern (Neff, 2003, 2015; Neff & Germer, 2017). Individuals who have self-compassion can lead a good life despite difficulties and do not escape suffering, and are always calm and positive. Self-compassion consists of three main dimensions in which self-kindness is contrary to self-judgment, that is, serving oneself well as opposed to harsh self-punishment, common humanity, as opposed to isolation, acknowledges that every individual has the experience of making mistakes as opposed to isolating and blaming self and the element of mindfulness (Neff, 2003). These components can make individuals accept the difficulties of life as part of the experience to become fully human (Neff & Costigan, 2014).

Self-compassion is based on the theory of Social Mentality by Gilbert (1989). This theory sees that individuals' desire to form relationships by obtaining various forms of biosocial goals can be achieved through mutual understanding of roles in a relationship. This theory is based on internal systems' concept to form patterns of thinking, influence, and behaviour that can produce social roles. Self-compassion is the source of happiness mentioned in eudemonic concepts (Ryan & Deci, 2001). In comparison, Neff and Costigan (2014) explain self-compassion as the understanding of not avoiding pain but nourishing with kindness and goodwill, producing a sense of well-being that is the basis of the experience of making human beings entirely. The compassion component is linked to the concept of a healthy personality by Maslow (1971) and Rogers (1980), which emphasizes unconditional self-acceptance and strives to reach one's full potential. According to them, when an individual is aware of suffering and acts with kindness and understands that suffering is part of the human condition, the individual is able to overcome the struggle of life more easily.

Past studies have shown that self-compassion is related and contributes to counsellors' well-being (Beaumont et al., 2016; Fairbanks, 2016; Todd, 2017). Beaumont et al. (2016) found that lack of self-care strategies for an extended period resulted in counsellors and psychotherapists at risk of burnout and compassionate fatigue. His findings showed that students' counsellors and cognitive behavioural psychotherapy are at a high level of self-compassion and well-being, meanwhile compassionate fatigue and burnout were reported at low levels. Therefore, the self-compassion practice can help student practitioners manage these fatigue symptoms and burnout and, in turn, can improve the quality of their professional life. Meanwhile, Fairbanks (2016) showed that self-compassion and self-awareness were

positively associated with well-being. The results also showed that self-compassion alone is consistently the most substantial predictive factor.

Furthermore, Todd (2017) explains that school counsellors act as the frontlines in dealing with trauma and crisis in their school. Counsellors who understand the importance of personal well-being will practise healthy lifestyle behaviours, even though some school counsellors do not model a positive lifestyle and self-care. This study explores the school counsellors' experience who can prioritize and integrate the principles of well-being and self-compassionate behaviour and can survive in the career profession for ten years or more. His findings showed that school counsellors combine positive self-compassion and positive well-being behaviours. In conclusion, the importance of well-being and self-compassion towards the counsellor's profession, help improve the quality of counselling services.

#### *Counseling Self-Efficacy Scale*

Self-efficacy is an individual's ability and confidence in performing well-assigned tasks (Bandura, 1997). Meanwhile, counselling self-efficacy is an individual's assessment of their ability to conduct counselling sessions effectively (Larson & Daniels, 1998). Individuals with good counselling self-efficacy can conduct counselling sessions and assignments more perfectly. High counselling self-efficacy can increase motivation and job achievement as well as being able to manage challenges effectively (Bandura, 1982). Besides, a high level of self-efficacy can reduce uncertain situations and increase efforts to meet the challenges faced (Bandura, 1977). Larson and Daniels (1998) adapted Bandura's concept of self-efficacy to introduce counselling self-efficacy. They applied Bandura's theory of self-efficacy to see counsellors' counselling self-efficacy through Social Cognitive Model of Counsellor Training. This model guides in helping counsellors to deliver effective services to clients (Larson & Daniels, 1998).

Past studies support that counselling self-efficacy has a relationship with well-being (Ellis, 2019; Ghazali et al., 2017). Ghazali et al. (2017) found that when counselling self-efficacy increases, counsellors' well-being also increases. Meanwhile, Ellis's (2019) findings showed that three-dimensional burnout predicts well-being. The conclusion that the relationship between the three dimensions of burnout and counsellors' well-being is partly mediated by the counsellor's self-efficacy and maintaining counsellors' career. However, Curry's (2007) study found that counselling self-efficacy had nothing to do with counsellors' wellness. He also explains that counsellor training focuses on counselling practitioners' difficulties and challenges, resulting in high stress, burnout, compassion fatigue, substitution trauma, and instability. He suggested that further research should be conducted to look at the relationship between the two variables, thus this attracts researchers to determine the influence of counselling self-efficacy on counsellors' psychological well-being.

#### *Emotional Intelligence*

Emotional intelligence is an individual's ability to produce perception, reasoning, understanding the emotions of himself and other individuals (Mayer & Salovey, 1997). While Goleman (1995) gives the impression that emotional intelligence is an individual's ability to manage his own emotions, motivate himself, and manage others' emotions. Individuals with high emotional intelligence can master the characteristics of perseverance when facing with failure, self-compassion, wisely manage their feelings even in difficulties or happiness, and have high self-empathy. This study's emotional intelligence component is based on the emotional intelligence model developed by Mayer and Salovey (1997). The four branch of emotional intelligence model distinguishes four areas of problem-solving needed to support emotional reasoning, namely (a) the ability to describe and express perceptions related to emotions, (b) facilitate thinking by using emotions or the ability to adjust emotions, (c) understand emotions, and (d) manage emotions to oneself and others (Mayer & Salovey, 1997).

In general, several previous studies have concluded that the element of emotional intelligence can develop the counselors' well-being (Reping, 2017) and trainee counselors (Ghazali et al., 2017; Merrill, 2019). Therefore, emotional intelligence is an essential element in improving counselors' well-being to manage themselves well and provide effective services to their clients. Meanwhile, Merrill's (2019) findings showed that there is still a direct and significant effect between emotional intelligence and the well-being component, particularly the mental and spiritual aspects. The emotional intelligence trait seems to continue to play an important role in developing trainee counselors, particularly on how they engage in mental and spiritual well-being behaviors. Meanwhile, counselors who have a strong level of emotional intelligence can prevent burnout and deliver effective services (Gutierrez et al., 2019; Gutierrez & Mullen, 2016).

#### *Spiritual Intelligence*

Spiritual intelligence is related to personal knowledge and practice that reflects the elements of meaning and value in life (Zohar & Marshall, 2000). Meanwhile, Hatch et al., (1998) define spiritual intelligence as the mind's ability to be reflected from a noble heart to build admirable nature and morals. In addition, spiritual intelligence can be assumed as competencies, abilities, and behaviours in nurturing the experience of love to form the value of responsibility (Zohar, 2005; Zohar & Marshall, 2000). Besides, Karim (1991) views spiritual intelligence as the ability of the spirit in which

spiritual intelligence increases as the soul gets closer to Allah. Individuals who have the characteristics of spiritual intelligence will have a positive attitude in handling challenges and developing after making mistakes, shortcomings, and misery. The component of spiritual intelligence in this study is based on Zohar and Marshall's theory of spiritual intelligence (2000). They explained that spiritual intelligence is the most important, highest intelligence, and the primary source is needed for the function of intellectual and emotional intelligence.

Spiritual intelligence seeks to improve counsellors' psychological well-being (Hosseini & Amirianzadeh, 2018) and the wellness of trainee counsellors (Ghazali et al., 2017). In addition, spiritual intelligence plays a role in reducing counsellor burnout (Hardiman & Simmonds, 2013). The study of Hosseini and Amirianzadeh (2018) explores the role of spiritual well-being as a mediator of the relationship between attachment styles and counsellor Isfahan's psychological well-being. The results show that attachment styles have a direct relationship with spiritual well-being. In conclusion, spiritual well-being plays a vital role in the relationship between attachment styles and psychological well-being. Meanwhile, the study of Hardiman and Simmonds (2013) explained that burnout is a risk to counsellors and psychotherapists in their careers dealing with troubled clients. He sees a link between spiritual well-being and burnout among counsellors and psychotherapists.

### Methodology

This study was conducted with a quantitative approach using a correlation study design. This study determined the relationship of independent variables that is between self-compassion (BELAS), counseling self-efficacy (EFIKASI), emotional intelligence (K\_EMOSI), spiritual intelligence (K\_SPIRITUAL) with psychological well-being (K\_PSIKO) as the dependent variables. Next, inferential analysis was used to identify independent variables' contribution towards dependent variables is through Structural Equation Modeling (SEM) using AMOS. Therefore, to perform statistical tests of the Equation Model in producing a study model, it is necessary to determine a large sample size so that the findings are meaningful. Kline (2011) suggested a sample size of 200 or more while Hair et al. (2010) suggested that the sample size should be at least 200 and not more than 400 because the sample size that exceeds 400 will cause sensitivity and the goodness of fit model become weak. In this regard, researchers took all the considerations and set a sample of 330 high school counselors from four districts in Selangor. The cluster sampling method was used to select respondents.

This study uses five scales to measure different variables, namely Self Compassion Scale, Counseling Self Estimate Inventory (COSE), The Assessing Emotions Scale (AES), Spiritual Involvement and Beliefs Scaled Revised (SIBSR-R), and Psychological Well Being-Ryff (PWB). To assess whether the data were free from the common method bias issue, Harman's single factor test was performed (Podsakoff et al., 2003). It was found that 41.7% of the variance was explained by one factor indicating that there was no common bias method issue in this study (less than 50%). All questionnaires used were translated into Malay. Neff develops the Self-Compassion Scale (2003), which has 26 items with six constructs, namely self-kindness (5 items), self-judgment (5 items), common-humanity (4 items), isolation (4 items), mindfulness (4 items), and over-identification (4 items). The reliability of this scale is .92 (Neff, 2003). Meanwhile, Counseling Self Estimate Inventory (COSE) developed by (Larson et al., 1992) has 37 items and five constructs, namely micro-skills (12 items), process (10 items), challenging client behaviors (7 items), cultural competence (4 items) and awareness of values (4 items). The reliability of this scale is .93 (Larson et al., 1992). Next, The Assessing Emotions Scale (AES) developed by Schutte et al. (2009) has four dimensions, namely, perception of emotions (10 items), managing emotions in the self (9 items), social skills, or managing others' emotions (8 items), and utilizing emotions (6 items). This scale with Cronbach's alpha reliability .90 (Schutte et al., 2009). Spiritual Involvement and Beliefs Scaled Revised (SIBSR-R) was developed by Hatch et al. (1998) and has been adapted by Zakaria (2011) contains 36 items and four dimensions, namely, spiritual basis (24 items), existence (6 items), self-application (3 items) and acceptance dimension (3 items). The reliability of the spiritual intelligence scale is as high as .92 (Hatch et al., 1998). Meanwhile, the Psychological Well Being-Ryff (PWB) scale developed by (Ryff & Keyes, 1995) has 54 items and six dimensions, namely self-acceptance (9 items), positive relationships with other individuals (9 items), autonomy (9 items), environmental mastery (9 items), life goals (9 items) and personal growth (9 items). Meanwhile, this scale's reliability is also high, which is between .86 to .93 (Ryff, 1989). Outliers are identified by using Mahalanobis distance method. Samples with Mahalanobis distance squared greater than the critical chi-square value ( $p < 0.001$ ) were dropped from further analysis (Tabachnick & Fidell, 2007). To assess the normality assumptions of a distribution, the values of skewness and kurtosis are used. Normality assessment for each sub-construct found that each item was in the range of -3 and +3 for skewness coefficient and was in the range of -10 and +10 for the kurtosis coefficient (Kline, 2011). This proves that the normality assumption has been adhered to. To assess the normality assumptions of a distribution, the values of skewness and kurtosis are used. Normality assessment for each sub-construct found that each item was in the range of -3 and +3 for skewness coefficient and was in the range of -10 and +10 for the kurtosis coefficient (Kline, 2011). This proves that the normality assumption has been adhered to.

## Results

### Confirmatory Factory Analysis (CFA)

To determine the validity of this study's constructs, the confirmatory factor analysis (CFA) approach was used. CFA focuses only on the relationship between the factors and items in the questionnaire, known as the measurement model. In this study, the researchers analyzed the latent construct only (Pooled CFA). For the steps for SEM analysis, the three criteria that must be followed are unidimensionality, validity, and reliability. Pooled CFA must be implemented to achieve the three criteria stated before carrying out the structural equation modelling process. The process for unidimensionality is met when all measuring items have acceptable factor loading for that respective latent construct. In order to ensure unidimensionality of a measurement model, item with low factor loading ( $< 0.60$ ) should be deleted. Items with a factor loading less than 0.6 would result a weak construct in measurement models. Items with a factor loading less than 0.6 must be excluded from the measurement model, even if the fit indices for the measurement model is reached (Awang, 2014). However, according to Byrne (2010) and Hair et al., (2010), factor load should exceed 0.5. Assessment for validity namely convergent validity, construct validity and discriminant validity are required prior to modelling the structural model. Conditions for convergent validity can be met when all items or dimensions in the measurement report significant values are verified through Average Variance Extracted (AVE) values. While the validity of the construct can be seen through the fit indices values (goodness-of-fit, GOF) and then the discriminant validity is achieved if the square root of AVE value belonging to particular construct is greater than any correlation among any pair of latent constructs.

Next, the reliability of the measurement model is seen through the internal reliability (Cronbach's alpha value), exceeding 0.7 while the CR value must be equal to or more than 0.6. The AVE value must be equal to or greater than 0.5 for each construct to achieve reliability. The table 1 shows the validity and reliability criteria by which construct reliability (CR) and AVE values are measured. Table 1 show the summary of validity and reliability.

Table 1. Summary of Validity and Reliability

Criteria	Characteristics
One dimensional	If factor loading more than 0.6
Validity	Convergent Validity, AVE value greater than 0.5 Construct Validity, (Fitness Indexes), Chisq $p > 0.05$ , RMSEA $< 0.80$ , GFI $> 0.90$ , AGFI $> 0.90$ , CFI $> 0.90$ , TLI $> 0.90$ , Chisq/df $> 5.0$
	Discriminant validity. Correlation between the variable lower than 0.85
Reliability	Internal reliability, Cronbach alpha $> 0.7$
	Construct reliability, CR $> 0.6$ Average Variance Extracted, AVE $> 0.5$

There are three categories of fit indices to measure the model fit with the data. Among them are absolute fit, incremental fit, and parsimonious fit. The fit consists of the Goodness of Fit Index (GFI) and Root Mean Square of Error Approximation (RMSEA). Incremental fit also consists of Adjusted Goodness of Fit (AGFI), Comparative Fit Index (CFI), Tucker Lewis Index (TLI), and Normed Fit Index (NFI). The next parsimonious fit consists of Chi-Square / Degree of Freedom (Chi-Square/df). The fit indices values for GFI, CFI, TLI, NFI should be greater than 0.90, indicating a right level of fit, while RMSEA less than 0.8 and Chi-Square/df less than 0.3 indicate good fit (Hair et al., 2010). The fit indices to the category and the level of acceptance of is shown in the table 2.

Table 2. Index Categories and Minimum Index (Awang, 2014)

Category	Name of index	Level of acceptance	Comment	References
Absolute fit	Chi-Square two ( $\chi^2$ )	$p > 0.05$	Sample size $> 200$	Wheaton et al. (1977)
	Root of Mean Square Error of Approximation (RMSEA)	RMSEA $< 0.08$	A range of 0.05 to 0.10 is acceptable	Browne and Cudeck (1993)
	Goodness of Fit Index (GFI)	GFI $> 0.90$	GFI = 0.95 is good match	Joreskog and Sorbom (1984)
Incremental fit	Comparative Fit Index (CFI)	CFI $> 0.90$	CFI = 0.95 is good match	Bentler (1990)
	Tucker Lewis Index (TLI)	TLI $> 0.90$	TLI = 0.95 is good match	Bentler and Bonett (1980); (Hair et al., 2010)
Parsimonious fit	Chi-square / df ( $\chi^2 / df$ )	$(\chi^2 / df) < 5.0$	Should $< 5.0$	Marsh and Hocevar (1985)

Pooled CFA and structured model fit are sufficient by looking at only one fit indices from each index category for construct validity for model acceptance (Awang, 2014).

Item Parcelling

Item parcelling is often used in an empirical analysis of structured equations model (SEM) since Cattell introduced it in 1956 (Bandalos, 2002; Kishton & Widaman, 1994; Little et al., 2002). Parcelling refers to a procedure for calculating the total or average score between several items. These total or average scores are then used as indicators in latent constructs in SEM analysis, rather than individual item scores (Bandalos, 2002, 2008; Little et al., 2002; Yang et al., 2010). Previous studies have shown that item parcelling has been used for latent constructs such as attitudes, which aims to reduce the influence of systematic error for each item on the estimated model and also help obtain a better model with corresponding data (Little et al., 2002; Yang et al., 2010). This study uses item parcelling in structured equation model (SEM).

Pooled Measurement Model

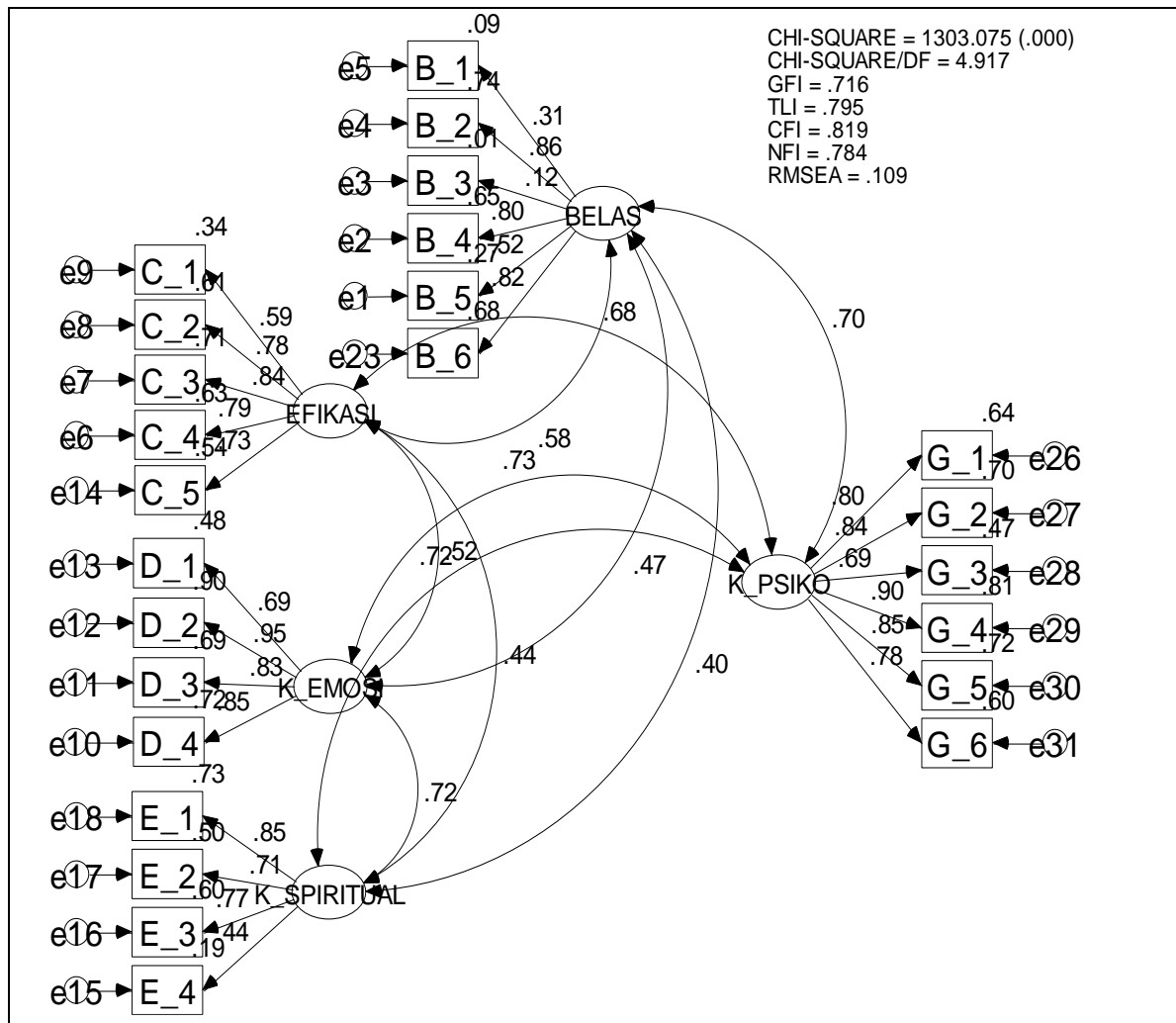

Figure1. Pooled Measurement Model for All Constructs

In the Figure 1, B represents self-compassion (BELAS), which has six constructs; C represents counselling self-efficacy (EFIKASI) with five constructs; D represents emotional intelligence (K\_EMOSI) with four constructs; E represents spiritual intelligence (K\_SPIRITUAL) with four constructs and G represents psychological well-being (K\_PSIKO) which has six constructs. Assessment on the measurement model were conducted. However, an unsatisfactory fitness index was obtained compared to the minimum index for model fitness statistics, referring to the table above. Therefore, modifications or reviews are needed to improve the model fitness index, considering the factor loading of the item and establishing a correlation between error terms.

Table 3. Summary Fit Statistics of Measurement Model

Fit statistics	Minimum index	Basic AFP index
Chi-Square	-	1303.075
p-value	p > 0.05	< 0.001
CMIN/dk	< 5.0	4.917
CFI	> 0.90	0.819
TLI	> 0.90	0.795
GFI	> 0.90	0.716
RMSEA	< 0.08	0.109

The findings showed that the re-specified Confirmatory Factor Analysis model does not have a satisfactory fit model. Some items have a factor loading value of less than 0.50. As a result, items B\_1, B\_3, B\_5, and E\_4 were eliminated.

Pooled Measurement Model (Re-specified model)

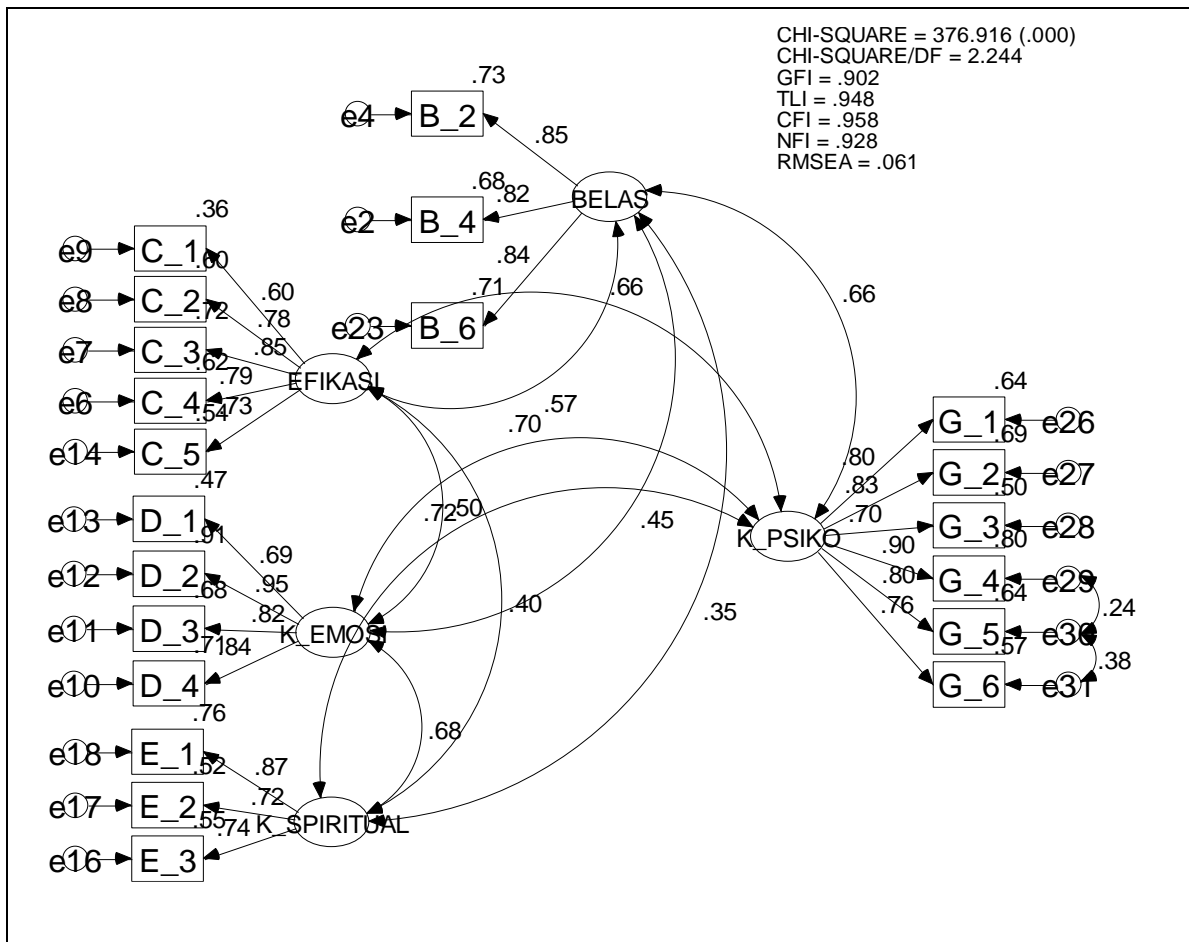

Figure 2. Pooled Measurement Model (Revised) for All Constructs

Table 4. Summary of Measurement Model Fitness Statistics (Revised)

Fit statistics	Minimum index	Basic CFA index
Chi-Square	-	376.916
p-value	p > 0.05	< 0.001
CMIN/dk	< 5.0	2.244
CFI	> 0.90	0.958
TLI	> 0.90	0.948
GFI	> 0.90	0.902
RMSEA	< 0.08	0.061

The findings in figure 2 showed that Confirmatory Analysis Model has satisfactory fitness model. It was found that the exogenous variables, namely self-compassion, counselling self-efficacy, emotional and spiritual intelligence, are each



significantly correlated with each other. Self-compassion showed a moderate positive relationship with psychological well-being [ $r = .663, p < .05$ ], counselling self-efficacy showed a moderate positive relationship with psychological well-being [ $r = .660, p < .05$ ]. Meanwhile, emotional intelligence showed a strong positive relationship with psychological well-being [ $r = .702, p < .05$ ] and spiritual intelligence showed a strong positive relationship with psychological well-being [ $r = .716, p < .05$ ].

Table 5. Relationship Results Between Self-Compassion, Self-Efficacy of Counselling, Emotional Intelligence, Spiritual Intelligence and Psychological Well-Being

Dependent Variable	Independent Variable	r	p-value
Psychological Well Being	← Self- Compassion	0.663	<0.001*
Psychological Well-being	← Counselling self-efficacy	0.660	<0.001*
Psychological Well being	← Emotional Intelligence	0.702	<0.001*
Psychological Well-being	← Spiritual Intelligence	0.716	<0.001*

\* p-value < 0.05

Referring to the table 5, Ha1 states that there is a significant relationship between self-compassion and psychological well-being. The results of the study found that there was a significant relationship between self-compassion and school counsellors' psychological well-being. Therefore, Ha1 is accepted. Ha2 further states a significant relationship between counselling self-efficacy of and psychological well-being. The results of the study found that there is a significant relationship between counselling self-efficacy and school counsellors' psychological well-being. Therefore, Ha2 is accepted. Meanwhile, Ha3 states that there is a significant relationship between emotional intelligence and psychological well-being. The results of the study found that there is a significant relationship between emotional intelligence and school counsellors' psychological well-being. Therefore, Ha3 is accepted. Moreover, Ha 4 states a significant relationship between spiritual intelligence and psychological well-being. The results of the study found that there is a significant relationship between spiritual intelligence and school counsellors' psychological well-being. Therefore, Ha4 is accepted.

#### Validity and Reliability of the Confirmatory Factor Analysis of the Study Model

Table 6. Validity and Reliability of Constructs

Construct	Number of original items	Number of items remaining	Factor loading	CR > 0.60	AVE > 0.50	Cronbach's Alpha
Self- Compassion	6	3	0.824 - 0.853	0.877	0.705	0.877
Counselling self-efficacy	5	5	0.598 - 0.846	0.866	0.566	0.860
Emotional Intelligence	4	4	0.687 - 0.952	0.899	0.692	0.897
Spiritual Intelligence	4	3	0.719 - 0.873	0.823	0.610	0.808
Psychological Well-being	6	6	0.704 - 0.897	0.914	0.640	0.918

Average Variance Extracted (AVE) is used to determine the convergence validity, and a construct is said to achieve convergent validity if the AVE value exceeds 0.50. The table 6 shows that all constructs have AVE values greater than 0.50. Based on the above findings, then it can be concluded that convergent validity has been established.

#### Discriminant Validity

Furthermore, the discriminant validity showing the measurement model of a construct independent of overlapping items (Pallant, 2016) was reviewed by comparing the correlation between constructs with the AVE's square root value for each construct (Awang, 2014; Fornell & David, 1981). Discriminant validity is achieved when AVE's square root value is greater than the correlation value between constructs by respective rows and columns for that particular constructs. Therefore, findings from table 7 show that discriminant validity is achieved.

Table 7. Discriminant Validity

Construct	(1)	(2)	(3)	(4)	(5)
Self-Compassion (1)	<b>0.840</b>				
Counselling Self -Efficacy (2)	0.569	<b>0.752</b>			
Emotional Intelligence (3)	0.449	0.499	<b>0.832</b>		
Spiritual Intelligence (4)	0.355	0.401	0.679	<b>0.781</b>	
Psychological Well Being (5)	0.663	0.660	0.702	0.716	<b>0.800</b>

Evaluation of normality assumptions

Structural Equation Modelling (Original)

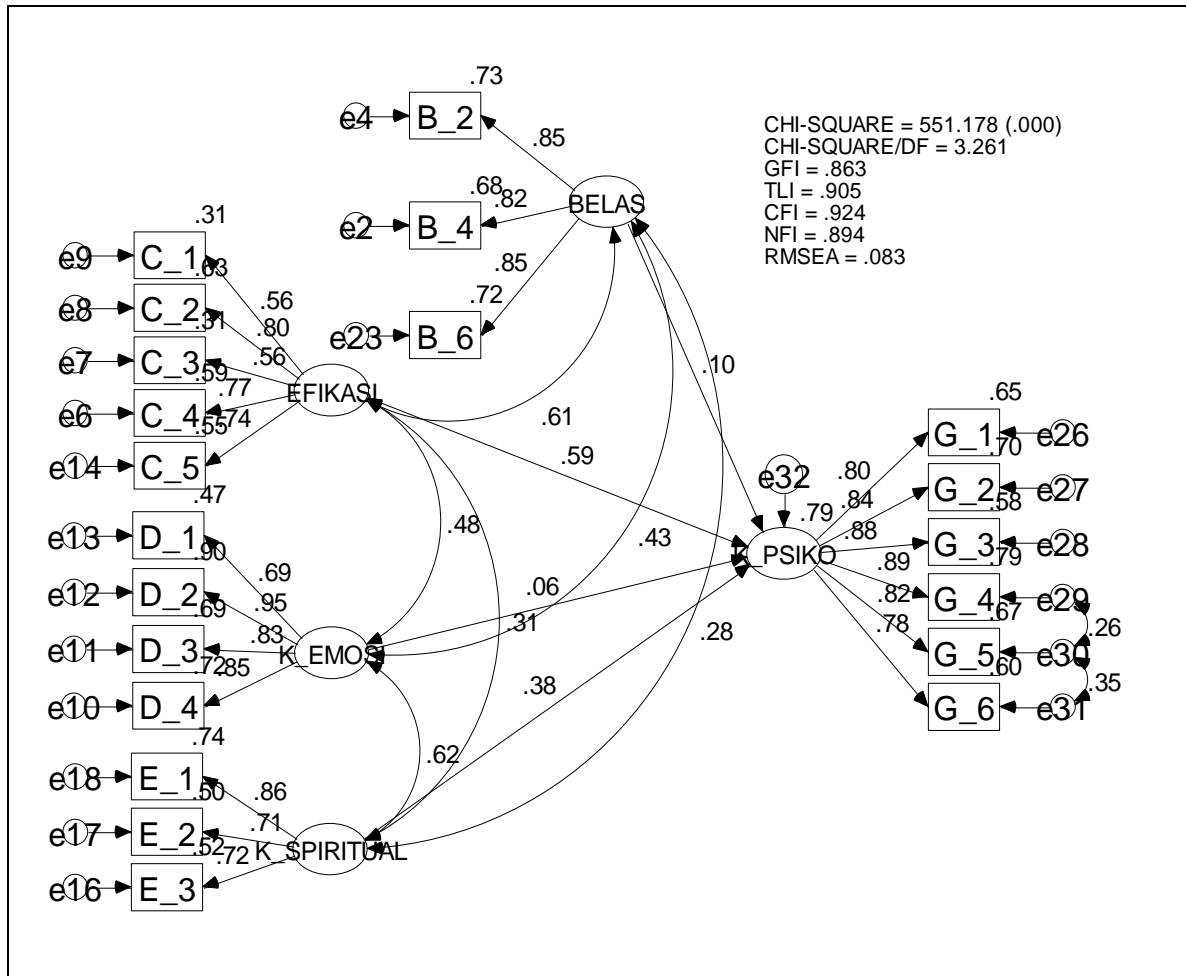

Figure 3. School Counsellors' Psychological Well-Being Model

Assessment on the measurement model were conducted. However, there were some unsatisfactory fit indices were obtained compared to the minimum index for model fitness statistics, referring to the table 8. Therefore, modifications or reviews are needed to improve the model fit indices by considering the factor loading and establishing a correlation between error terms.

Table 8: Summary of Measurement Model Match Statistics

Fit statistics	Minimum Index	Basic CFA index
Chi Square	-	551.178
p-value	p > 0.05	< 0.001
CMIN/dk	< 5.0	3.261
CFI	> 0.90	0.924
TLI	> 0.90	0.905
GFI	> 0.90	0.863
RMSEA	< 0.08	0.083

Structural Equation Model (Re-specified Model)

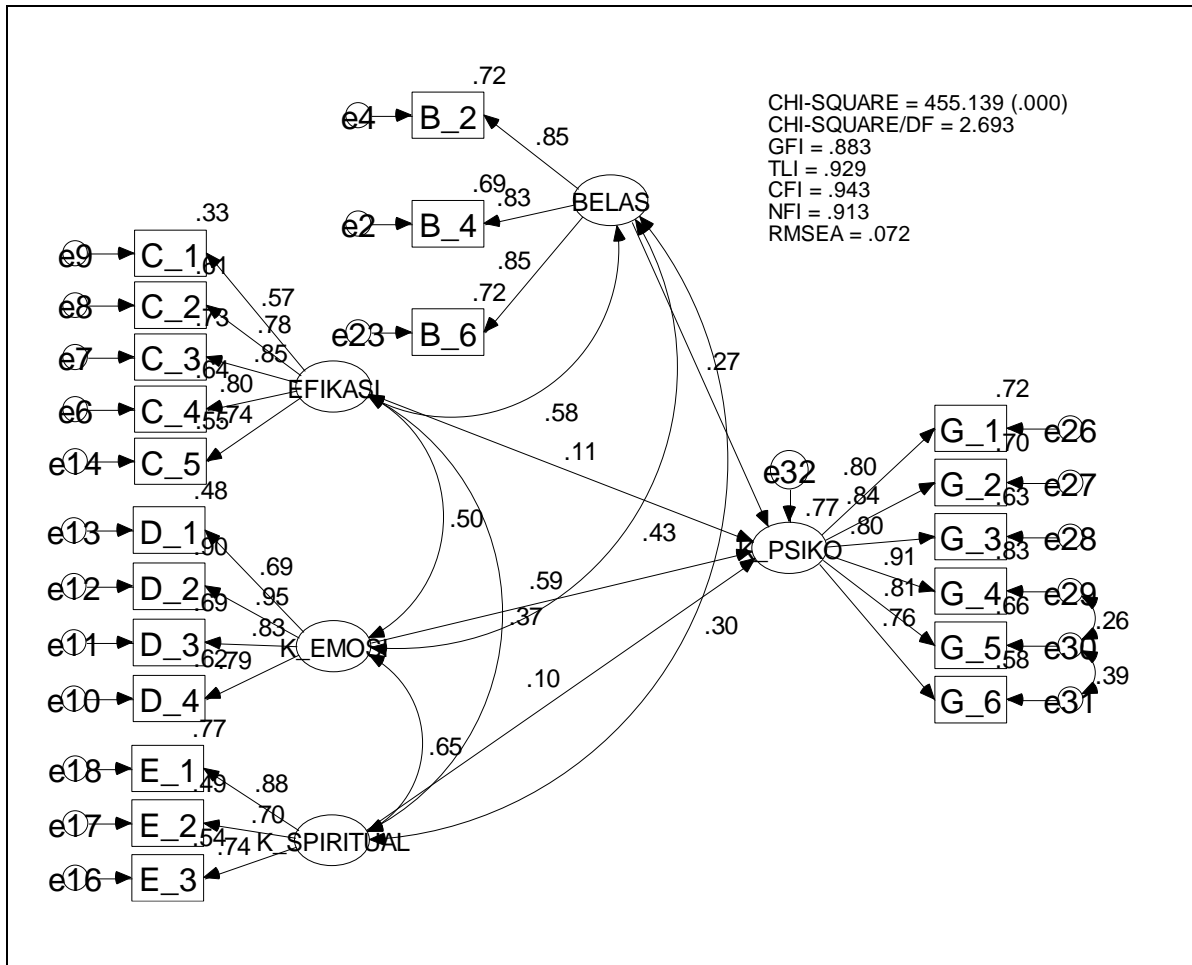

Figure 4. School Counsellors' Psychological Well-Being Model (Re-Specified Model)

In this section, assessment on structural model is discussed to study the effects of exogenous variables on endogenous variables. The figure 4 displays the structured model tested, showing the causal relationship between each construct in the study. A review of the analysis's output found that the factor loading and regression coefficients were within an acceptable range. The direction of the arrow in the structured model also indicates a reasonable and theoretical direction.

The results of the analysis found that the fit statistics are adequate with the normed chi-square values ( $\chi^2/df$ ) is 2.693, CFI = 0.943, TLI = 0.929, GFI = 0.883 and RMSEA = 0.072. In overall, the majority of fitness statistics used exceeded the threshold values suggested by most researchers.

Consequently, it was found that the value of the indices of this model meets the suggested fitness index by previous researchers, namely  $\chi^2 / df < 5.0$ , RMSEA  $< 0.08$ , CFI  $> 0.90$ , GFI approaching 0.90, and TLI  $> 0.90$  (Awang, 2014). This indicates that this model is suitable to test the relationship between self-compassion, counselling self-efficacy, emotional and spiritual intelligence with the psychological well-being of school counsellors. Furthermore, based on the findings of structured equations modelling, there are 76.5% variance in psychological well-being can be explained by self-compassion, counselling self-efficacy, emotional intelligence spiritual intelligence.

It was found that emotional intelligence constructs are the most significant contributors to school counsellors' psychological well-being with standardised regression weight,  $\beta_{\text{emotional intelligence}} = 0.586$ , followed by self-compassion ( $\beta_{\text{self-compassion}} = 0.268$ ), counselling self-efficacy ( $\beta_{\text{counselling self-efficacy}} = 0.107$ ) and spiritual intelligence ( $\beta_{\text{spiritual intelligence}} = 0.097$ ).

Below is table 9 shows fit Index for structured models and table 10 is the standardized regression weight.

Table 9. Corresponding Index for Structured Model

Parameter	Coefficient
$\chi^2$	455.139
$\chi^2/df$	2.693
p	< 0.001
RMSEA	0.072
TLI	0.929
CFI	0.943
GFI	0.883

Notes:  $\chi^2$ : Chi-square goodness of fit; df: Degrees of freedom; CFI: Comparative Fit Index; TLI: Tucker-Lewis Fit Index (TLI); RMSEA: Root Mean Square Error; GFI: Goodness of Fit Index

Table 10. Standardised Regression Weight

DV	IV	Beta Estimate	S.E	C.R	p
Psychological Well being	Self -Compassion	.268	.050	5.538	< 0.001*
Psychological Well being	Counselling Self -Efficacy	.107	.041	2.216	0.027 *
Psychological Well being	Emotional Intelligence	.586			< 0.001*
Psychological Well being	Spiritual Intelligence	.097	.073	2.146	0.032*

\* p-value < 0.05

Referring to the table 10, Ha 5 hypothesis showed that self-compassion has a significant influence on school counsellors' psychological well-being with values ( $p < .05$ ). Hypothesis Ha 6 showed that counselling self-efficacy significantly influenced the psychological well-being of school counsellors with values ( $p < .05$ ). Meanwhile, Ha 7 hypothesis showed that emotional intelligence had a significant influence on the school counsellors' psychological well-being with values ( $p < .05$ ), and Ha 8 hypothesis showed that spiritual intelligence had a significant influence on the school counsellors' psychological well-being with values ( $p < .05$ ). Moreover, Ha9 hypothesis showed that the School Counsellor Psychological Well-being Model is compatible with the data of the study. Therefore, the hypotheses Ha5, Ha6, Ha7, Ha8, Ha9 are acceptable.

### Discussion

The findings of this study show that there is a positive relationship and influences between self-compassion and school counselors' psychological well-being. This is in line with the view of (Ryan & Deci, 2001), who found that self-compassion is a component in the eudemonic concept and Neff and Costigan (2014) also linked that self-compassion can make individuals feel prosperous. This finding is in line with Fairbanks (2016) study, but his study involved trainee counselors who found that self-compassion is a strong predictor factor. Beaumont et al. (2016) proved the findings to be similar to this study; only his study was on educator counselors and focused on mental well-being. However, both studies give the impression that self-compassion is an essential feature in developing the counselors' psychological well-being. This can improve the achievement and quality of counselor services in schools, especially offering effective counseling services (Purwaningrum et al., 2019). The findings of the study also support Todd (2017), who explained that school counselors could survive in their careers by practicing self-compassion and well-being. Self-compassion is a factor that contributes to the school counselors' psychological well-being and thus helps school counselors cope with various demands of work in school.

Moreover, the findings of this study identify that emotional intelligence is related and contributes to psychological well-being. These findings coincide with Reping's (2017) study. However, his study measures the relationship of emotional intelligence with wellness. These findings of this study also strengthen the study of Ghazali et al. (2017) and Merrill (2019) study examining trainee counselors. All previous studies have found that the higher the level of emotional intelligence, the higher the counselors' well-being. This suggests that the component of emotional intelligence can further strengthen the school counselors' psychological well-being. This is emphasized by Harris et al. (2013) and Merryman et al. (2015) in their study explaining that psychological well-being is related to counselors' wellness perceptions. Counselors who have high psychological well-being characteristics will always be positive, strive to develop their potential, and encourage self-growth to become stronger individuals to face the challenges (Ryff, 1989). Emotional intelligence can be a catalyst for school counselors' psychological well-being and a suitable mechanism of self-care in avoiding issues such as burnout and being able to offer superior services in schools.

Furthermore, the findings of the study support the study of Hosseini and Amiranzadeh (2018), which shows that there is a relationship between spiritual factors and counselors psychological well-being. Moreover, Ghazali et al. (2017) also confirmed that spiritual intelligence plays a role in the trainee counselors' wellness. In addition, spiritual elements can help reduce the risk of counselors' burnout (Hardiman & Simmonds, 2013) and, in turn, shape the characteristics of psychological well-being. Spiritual component combines the values towards perfect behaviours and later builds counselors' objectives, have good relationship with others as well as wise in decision making in personnel and

professionals. This can help counselors become more mature, have happy characteristics, and fully function in carrying various responsibilities in school. So, counselors need to cultivate psychological well-being practices to balance their situation and be able to form positive thoughts and behaviors, which can reduce the stress faced (Augustine & Anuradha, 2015).

In overall, the findings of the study can produce school counselors' psychological well-being model which matches the data of the study and found that 76.5% variance in psychological well-being is explained by all factors of self-compassion, counseling self-efficacy, emotional and spiritual intelligence. The emotional intelligence factor is the most significant contributor to the counselors' psychological well-being. These findings indicate that all of the contributing factors selected in this study are appropriate and capable of improving school counselors' psychological well-being. Based on previous studies, only a few studies focus on the counselors' psychological well-being, for example, a study by Fairbanks (2016) only combines self-compassion and mindfulness that contributes 64.9% variance to trainee counselors' psychological well-being. Meanwhile, Ellis's (2019) counselor wellness model only focuses on counseling self-efficacy factors with burnout and career defending behaviors. Therefore, the findings give the impression that the aspects of self-compassion, counseling self-efficacy, emotional and spiritual intelligence, and psychological well-being should be considered in strengthening the school counselors' profession in delivering better quality services.

### Conclusions

In conclusion, the findings of this study answer all the research questions. Studies prove that there are a relationship and influence between self-compassion, counseling self-efficacy, emotional intelligence, spiritual intelligence and school counselors' psychological well-being. This study was also able to produce a model of psychological well-being for school counselors. The school counselors' psychological well-being model can be used as a guide to the university, MoEM, and the Board of Counselors to produce prosperous counselors and perform services professionally. At the university level, training and curriculum in the field of guidance and counseling can be improved by applying self-care elements, primarily psychological well-being, and aspects of self-compassion, self-counseling, emotional, and spiritual intelligence. This proposal is in line with Osborn's (2004) view, which suggested focusing on building counselor resilience rather than focusing on the stress and shortcomings faced because preventing fatigue or exhaustion is a reactive response while focusing on counselors' well-being is proactive.

Besides, the Ministry of Education Malaysia can regard the psychological well-being model as a reference base in building proper training and interventions to increase school counselors' psychological strength to face the challenges and various students' issues in school. Meanwhile, the Malaysian Board of Counselors can provide professional courses to school counselors and formulate appropriate strategies in developing the school counselors' competence who are always smart in balancing psychological well-being and do not neglect the aspect of personal care in personnel and professionals. In addition, some previous studies on psychological well-being in Malaysia only focused on organizational counselors (Ismail et al., 2017) and counselors at the Mara Institute of Education (Nasharudin & Amat, 2017). Hence, the findings of this study can fill the gaps of the importance of counseling school.

### Recommendations

Based on this study, it is proposed that further research should focus on qualitative studies based on interview in order to be able to explore in depth the factors that can contribute to the school counselors' psychological well-being. Besides, the identified factors that can improve psychological well-being also can be included in the interviews conducted. The findings and information in this interview will be more meaningful and can be used to guide the MoEM in designing training modules to strengthen the quality of school counselor services.

### Limitations

This study has some limitations that can be identified and can be used as a backup. The sample of this study involves secondary school counselors only and does not involve primary school counselors. Apart from that, the population of the study administered only involved four District Education Offices in Selangor. Furthermore, this study only focused on psychological well-being related to self-compassion, counselling self-efficacy, emotional intelligence, and spiritual intelligence. Meanwhile, there are studies found that social supports affect psychological well-being.

Such suggestions or ideas can be considered to improve school counselors' self-compassion, counseling self-efficacy, emotional intelligence dan spiritual intelligence. School counselors need to be alert and focused on practicing all the factors discussed to deliver more effective services in school and always positive in performing every task.

### Authorship Contribution Statement

Bali-Mahomed: Conceptualization, design, analysis, writing, interpretation, drafting manuscript. Ku-Johari: Editing/reviewing, supervision, technical, material support, final approval. Mahmud: Reviewing, supervision, technical, material support. Amat: Statistical analysis, technical, material support. Saadon: Statistical analysis, technical.

## References

- American Counseling Association. (2014). *ACA code of ethics*. Ethics Archive. <https://bit.ly/3s3MuB>
- Arnout, B. A., & Almoied, A. A. (2021). A structural model relating gratitude, resilience, psychological well-being and creativity among psychological counsellors. *Counselling and Psychotherapy Research*, 21(2), 470-488. <https://doi.org/10.1002/capr.12316>
- Augustine, L., & Anuradha, S. (2015). School counsellors' insights on well-being. *International Journal of Management and Social Science Research Review*, 1(9), 180-188. <https://bit.ly/3pHzVYs>
- Awang, Z. (2014). *A handbook on SEM for academicians and practitioners*. MPWS Rich Publication.
- Bandalos, D. L. (2002). The effects of item parceling on goodness-of-fit and parameter estimate bias in structural equation modeling. *Structural Equation Modeling*, 9(1), 78-102. [https://doi.org/10.1207/S15328007SEM0901\\_5](https://doi.org/10.1207/S15328007SEM0901_5)
- Bandalos, D. L. (2008). Is parceling really necessary? A comparison of results from item parceling and categorical variable methodology. *Structural Equation Modeling*, 15(2), 211-240. <https://doi.org/10.1080/10705510801922340>
- Bandura, A. (1977). Self-efficacy: Toward a unifying theory of behavioral change. *Psychological Review*, 84(2), 191-215. <https://doi.org/10.1037/0033-295x.84.2.191>
- Bandura, A. (1982). Self-efficacy mechanism in human agency. *American Psychologist*, 37(2), 122-147. <https://doi.org/10.1037/0003-066X.37.2.122>
- Bandura, A. (1997). *Self-efficacy: The exercise of control*. W. H. Freeman.
- Bardhoshi, G., Schweinle, A., & Duncan, K. (2014). Understanding the impact of school factors on school counselor burnout: A mixed-methods study. *The Professional Counselor*, 4(5), 426-443. <https://doi.org/10.15241/gb.4.5.426>
- Beaumont, E., Durkin, M., Hollins Martin, C., & Carson, J. (2016). Measuring relationships between self-compassion, compassion fatigue, burnout and well-being in student counsellors and student cognitive behavioural psychotherapists: A quantitative survey. *Counselling and Psychotherapy Research*, 16(1), 15-23. <https://doi.org/10.1002/capr.12054>
- Bentler, P. M. (1990). Comparative fit indexes in structural models. *Psychological Bulletin*, 107(2), 238-246. <https://doi.org/10.1037%2F0033-2909.107.2.238>
- Bentler, P. M., & Bonett, D. G. (1980). Significance tests and goodness of fit in the analysis of covariance structures. *Psychological Bulletin*, 88(3), 588-606. <https://doi.org/10.1037/0033-2909.88.3.588>
- Brand, K. (2019). School counselor self-care practices as mitigating factors regarding professional burnout. *Counselor Education Capstones*, 99, 1-27. <https://bit.ly/3yqxpw0>
- Browne, M. W., & Cudeck, R. (1993). Alternative ways of assessing model fit. In K. A. Bollen & J. S. Long (Eds.), *Testing structural equation models* (pp. 136-162). Sage.
- Byrne, B. M. (2010). *Structural equation modeling with AMOS: Basic concepts, application and programing*. Lawrence Erlbaum Associates.
- Callender, K. A., & Lenz, A. S. (2018). Implications for wellness-based supervision and professional quality of life. *Journal of Counseling & Development*, 96(4), 436-448. <https://doi.org/10.1002/jcad.12225>
- Coaston, S. C. (2017). Self-care through self-compassion: A balm for burnout. *The Professional Counselor*, 7(3), 285-297. <https://doi.org/10.15241/scc.7.3.285>
- Curry, J. (2007). *An investigation of the relationship between counseling self-efficacy and counselor wellness among counselor education students* [Doctoral dissertation, University of Central Florida Orlando]. University of Central Florida - Stars. <https://bit.ly/3rSCcmm>
- Ellis, D. S. (2019). *Exploring the mediating effects between counselor self-efficacy, career sustaining behaviors, perceived wellness, and burnout among novice counselors: testing two proposed mediation models* [Doctoral dissertation, Sam Houston State University]. Sam Houston State University- Scholarly Works @ SHSU. <https://bit.ly/3GFI6eN>
- Fairbanks, L. (2016). *Self-compassion, mindfulness and wellbeing in counselors in training*. [Master's thesis, Central Washington University]. Central Washington University, ScholarWorks@CWU. <https://bit.ly/3yqj2kk>
- Fornell, C., & David, F. L. (1981). Evaluating structural equation models with unobservable variables and measurement error. *Journal of Marketing Research*, 18(1), 39-50. <https://doi.org/10.2307/3151312>
- Friedman, K. (2017). Counselor self-care and mindfulness. *Contemporary Buddhism*, 18(2), 321-330. <https://doi.org/10.1080/14639947.2017.1373437>

- Fye, H. J., Cook, R. M., Baltrinic, E. R., & Baylin, A. (2020). Examining individual and organizational factors of school counselor burnout. *The Professional Counselor, 10*(2), 235-250. <https://doi.org/10.15241/hjf.10.2.235>
- Ghazali, M., Noah, S. M., Jaafar, W. M. W., & Hassan, S. A. (2017). The influence of wellness perception, emotional intelligence, spiritual intelligence, and counselling self-efficacy towards counselor trainees' self-development. *Imperial Journal of Interdisciplinary Research, 3*(2). <https://www.onlinejournal.in/IJIRV3I2/236.pdf>
- Gilbert, P. (1989). *Human nature and suffering*. Psychology Press//Guilford Press.
- Golberstein, E., Wen, H., & Miller, B. F. (2020). Coronavirus disease 2019 (COVID-19) and mental health for children and adolescents. *JAMA Pediatrics, 174*(9), 819-820. <https://doi.org/10.1001/jamapediatrics.2020.1456>
- Goleman, D. (1995). *Emotional intelligence*. Bantam Books.
- Groarke, J. M., Berry, E., Graham-Wisener, L., McKenna-Plumley, P. E., McGlinchey, E., & Armour, C. (2020). Loneliness in the UK during the COVID-19 pandemic: Cross-sectional results from the COVID-19 Psychological Wellbeing Study. *PLOS ONE, 15*(9), e0239698. <https://doi.org/10.1371/journal.pone.0239698>
- Gutierrez, D., Butts, C. M., Lamberson, K. A., & Lassiter, P. S. (2019). Examining the contributions of trait emotional intelligence on addiction counselor burnout. *Journal of Addictions & Offender Counseling, 40*(1), 52-64. <http://doi.org/10.1002/jaoc.12056>
- Gutierrez, D., & Mullen, P. (2016). Emotional intelligence and the counselor: examining the relationship of trait emotional intelligence to counselor burnout. *Journal of Mental Health Counseling, 38*(3), 187-200. <http://doi.org/10.17744/mehc.38.3.01>
- Hair, J. F., Anderson, R. E., Tatham, R. L., & Black, W. C. (2010). *Multivariate data analysis: A global perspective* (7th ed.). Pearson Prentice Hall
- Hardiman, P., & Simmonds, J. G. (2013). Spiritual well-being, burnout and trauma in counsellors and psychotherapists. *Mental Health, Religion & Culture, 16*(10), 1044-1055. <http://doi.org/10.1080/13674676.2012.732560>
- Harris, M., Martin, M., & Martin, D. (2013). The relationship between psychological wellbeing and perceived wellness in graduate-level Counseling students. *Higher Learning Research Communications, 3*(2), 14-31. <https://doi.org/10.18870/hlrc.v3i2.91>
- Hatch, R. L., Burg, M. A., Naberhaus, D. S., & Hellmich, L. K. (1998). The spiritual involvement and beliefs scale revised. *Journal of Family Practice, 46*(6), 476-486. <https://bit.ly/3IK014o>
- Hosseini, F., & Amiranzadeh, M. (2018). The mediating role of spiritual well-being in the relationship between attachment styles and psychological well-being of Isfahan's counselors. *Indian Journal of Positive Psychology, 9*(2), 294-298. <https://www.proquest.com/docview/2158118414>
- Huat, C. S. (2018). The relationship between role conflict and burnout among secondary school counselors in Sarawak. *Global Business and Management Research: An International Journal, 10*(2), 10-22. <http://www.gbmr.ioksp.com/>
- Ismail, M., Jamaluddin, S., & Sumari, M. (2017). The counselors' psychological wellbeing. *International Journal of Academic Research in Business and Social Sciences 7*(3), 733-738. <https://bit.ly/3ITPII8>
- Jaafar, W. M. W. (2016). Counselor professionalism issues. In W. M. W. Jaafar, A. Awang, S. Amat & R. M. Min (Eds.), *Competencies of professional counselors* (pp.15-25). Lembaga Kaunselor.
- Johari, K. S. K., & Amat, M. I. (2019). Malaysian school counsellors' challenges in job description, job satisfaction and competency. *Religion, Science Magazine Sociality Humanities, 4*(19), 2477-9083. <https://bit.ly/3EP89zE>
- Joreskog, K. G., & Sorbom, D. (1984). *Advances in factor analysis and structural equation models*. Rowman & Littlefield Publishers.
- Karim, F. (1991). *Imam Ghazali's Ihya Ulumuddin: The book of religious learnings* (Vol. 3). Islamic Book Services.
- Keyes, C. L., Shmotkin, D., & Ryff, C. D. (2002). Optimizing well-being: the empirical encounter of two traditions. *Journal of Personality and Social Psychology, 82*(6), 1007-1022. <https://doi.org/10.1037/0022-3514.82.6.1007>
- Kim, N., & Lambie, G. W. (2018). Burnout and implications for professional school counselors. *The Professional Counselor, 8*(3), 277-294. <https://doi.org/10.15241/nk.8.3.277>
- Kishton, J. M., & Widaman, K. F. (1994). Unidimensional versus domain representative parceling of questionnaire items: An empirical example. *Educational and Psychological Measurement, 54*(3), 757-765. <https://doi.org/10.1177/0013164494054003022>
- Kline, R. B. (2011). Convergence of structural equation modeling and multilevel modeling. In M. Williams, & W. P. Vogt (Eds.), *The SAGE handbook of innovation in social research methods* (pp. 562-589). SAGE Publication Ltd. <https://www.doi.org/10.4135/9781446268261>

- Kuen, N. H. (2015). *The influence of counselor well-being on work involvement among counselors in Malaysia*. [Unpublished master's thesis]. Universiti Putra Malaysia
- Larson, L. M., & Daniels, J. A. (1998). Review of counseling self-efficacy literature. *The Counseling Psychologist*, 26(2), 179-218. <https://doi.org/10.1177/0011000098262001>
- Larson, L. M., Suzuki, L. A., Gillespie, K. N., Potenza, M. T., Bechtel, M. A., & Toulouse, A. L. (1992). Development and validation of the counseling self-estimate inventory. *Journal of Counseling Psychology*, 39(1), 104-120. <https://doi.org/10.1037/0022-0167.39.1.105>
- Lawson, G., Venart, E., Hazler, R. J., & Kottler, J. A. (2007). Toward a culture of counselor wellness. *The Journal of Humanistic Counseling, Education and Development*, 46(1), 5-19. <https://doi.org/10.1002/j.2161-1939.2007.tb00022.x>
- Little, T. D., Cunningham, W. A., Shahar, G., & Widaman, K. F. (2002). To parcel or not to parcel: Exploring the question, weighing the merits. *Structural Equation Modeling*, 9, 151-173. [https://doi.org/10.1207/S15328007SEM0902\\_1](https://doi.org/10.1207/S15328007SEM0902_1)
- Majumdar, P., Biswas, A., & Sahu, S. (2020). COVID-19 pandemic and lockdown: Cause of sleep disruption, depression, somatic pain, and increased screen exposure of office workers and students of India. *Chronobiology International*, 37(8), 1191-1200. <https://doi.org/10.1080/07420528.2020.1786107>
- Marsh, H. W., & Hocevar, D. (1985). Application of confirmatory factor analysis to the study of self-concept: First- and higher order factor models and their invariance across groups. *Psychological Bulletin*, 97(3), 562-582. <https://doi.org/10.1037/0033-2909.97.3.562>
- Maslow, A. H. (1971). *Self-actualization*. Big Sur Recordings.
- McLeod, J., & McLeod, J. (2014). *Personal and professional development for counsellors, psychotherapists and mental health practitioners*. McGrawHill Education. <https://www.mhebooklibrary.com/doi/book/10.1036/9780335247349>
- Merrill, E. A. (2019). *Wellness among counselors in training: examining the relationship between trait emotional intelligence, perceptions of stress, perceptions of wellness, and wellness behaviors* [Doctoral dissertations, University of North Carolina]. ProQuest Dissertations Publishing. <https://bit.ly/3IH55Yu>
- Merryman, W. S., Martin, N., & Martin, D. (2015). Relationship between psychological well-being and perceived wellness in online graduate counselor education students. *The Journal of Counselor Preparation and Supervision*, 7(1), 1-32. <https://doi.org/10.7729/71.1073>
- Ministry of Education. (2012). *Surat Siaran KPM Bil 12 Tahun 2012* [Information circular, no 12. 2012]. <https://bit.ly/31TwFRF>
- Mullen, P. R., & Crowe, A. (2017). Self-stigma of mental illness and help seeking among school counselors. *Journal of Counseling and Development*, 95(4), 401-411. <https://doi.org/10.1002/jcad.12155>
- Mullen, P. R., & Gutierrez, D. (2016). Burnout, stress and direct student services among school counselors. *The Professional Counselor*, 6(4), 344-359. <https://doi.org/10.15241/pm.6.4.344>
- Nasharudin, M., & Amat, S. (2017, July 12-13). *Psychological well-being and life satisfaction among counselors at the Mara Institute of Education* [Paper presentation]. National Social Work Conference, Social Institute of Malaysia, Kuala Lumpur, Malaysia.
- Neff, K. D. (2003). The development and validation of a scale to measure self-compassion. *Self and Identity*, 2(3), 223-250. <https://doi.org/10.1080/15298860309027>
- Neff, K. D. (2015). The self-compassion scale is a valid and theoretically coherent measure of self-compassion. *Mindfulness*, 7, 264-274. <https://doi.org/10.1007/s12671-015-0479-3>
- Neff, K. D., & Costigan, A. P. (2014). Self-compassion, well-being, and happiness. *Psychologie in Österreich*, 2(3), 114-119. <https://cutt.ly/2le0aRG>
- Neff, K. D., & Germer, C. (2017). Self compassion and psychological wellbeing. In E. Seppala, E. Simon-Thomas, S. Brown, M. Worline, D. Cameron & J. Doty (Eds.), *Oxford handbook of compassion science* (pp. 371-385). Oxford University Press. <https://doi.org/10.1093/oxfordhb/9780190464684.013.27>
- Osborn, C. J. (2004). Seven salutary suggestions for counselor stamina. *Journal of Counseling & Development*, 82(3), 319-328. <https://doi.org/10.1002/j.1556-6678.2004.tb00317.x>
- Pallant, J. (2016). *SPSS Survival Manual: A Step by step guide to data analysis using SPSS program* (6th ed.). McGraw-Hill Education.
- Patrick, S. W., Henkhaus, L. E., Zickafoose, J. S., Lovell, K., Halvorson, A., Loch, S., Letterie, M., & Davis, M. M. (2020). Well-being of parents and children during the COVID-19 pandemic: A national survey. *Pediatrics*, 146(4), 1-3. <https://doi.org/10.1542/peds.2020-0836>



- Podsakoff, P. M., MacKenzie, S. B., Lee, J.-Y., & Podsakoff, N. P. (2003). Common method biases in behavioral research: A critical review of the literature and recommended remedies. *Journal of Applied Psychology, 88*(5), 879-903. <https://doi.org/10.1037/0021-9010.88.5.879>
- Purwaningrum, R., Hanurawan, F., Degeng, N. S., & Triyono. (2019). School counselor's psychological well-being: a phenomenological study. *European Journal of Education Studies, 6*(2), 80-99. <https://oapub.org/edu/index.php/ejes/article/view/2418>
- Reping, F. (2017). *The relationship between personal well -being and emotional intelligence among counselors in Selangor, Malaysia* [Unpublished master's thesis]. Universiti Putra Malaysia.
- Rogers, C. R. (1980). *A way of being*. Houghton Mifflin.
- Roxas, M. M., David, A. P., & Aruta, J. J. B. R. (2019). Compassion, forgiveness and subjective well being among Filipino Counseling Professionals. *International Journal for the Advancement of Counselling, 41*, 272-283. <https://doi.org/10.1007/s10447-019-09374-w>
- Ryan, R. M., & Deci, E. L. (2001). On happiness and human potentials: A review of research on hedonic and eudaimonic well-being. *Annual Review of Psychology, 52*, 141-166. <https://doi.org/10.1146/annurev.psych.52.1.141>
- Ryff, C. D. (1989). Happiness is everything, or is it? explorations on the meaning of psychological well-being. *Journal of Personality and Social Psychology, 57*(6), 1069-1081. <https://doi.org/10.1037/0022-3514.57.6.1069>
- Ryff, C. D. (1995). Psychological well-being in adult life. *Current Directions in Psychological Science, 4*(4), 99-104. <https://doi.org/10.1111/1467-8721.ep10772395>
- Ryff, C. D., & Keyes, C. L. M. (1995). The structure of psychological well-being revisited. *Journal of Personality & Social Psychology, 69*, 719-727. <https://doi.org/10.1037/0022-3514.69.4.719>
- Salovey, P., & Sluyter, D. J. (Eds.). (1997). *Emotional development and emotional intelligence: Educational implications*. Basic Books.
- Sanders, C., Welfare, L., & Culver, S. (2017). Career counseling in middle schools: A study of school counselor self-efficacy. *The Professional Counselor, 7*(3), 238-250. <https://doi.org/10.15241/cs.7.3.238>
- Schutte, N. S., Malouff, J. M., & Bhullar, N. (2009). The assessing emotions scale. In C. Stough, D. H. Saklofske, & J. D. A. Parker (Eds.), *Assessing emotional intelligence* (pp.119-134). Springer Publishing. [https://doi.org/10.1007/978-0-387-88370-0\\_7](https://doi.org/10.1007/978-0-387-88370-0_7)
- Skovholt, T. M., & Mathison, M. T. (2016). *The resilient practitioner burnout and compassion fatigue prevention and self care strategies for the helping professions* (3rd ed.). Taylor and Francis Group, LLC. <https://doi.org/10.4324/9781315737447>
- Stephanou, G., & Athanasiadou, K. (2020). Interpersonal relationships: cognitive appraisals, emotions and hope. *European Journal of Psychology and Educational Research, 3*(1), 13-38. <https://doi.org/10.12973/ejper.3.1.13>
- Tabachnick, B. G., & Fidell, L. S. (2007). *Using multivariate statistics* (5th ed.). Allyn & Bacon/Pearson Education.
- Todd, A. (2017). *An exploration of self-compassion and wellness behaviors among practicing school counselors* [Doctoral dissertation, University of South Florida]. Digital Commons @ University of South Florida. <https://bit.ly/3ILDvED>
- Wheaton, B., Muthen, B., Alwin, D., & Summers, G. (1977). Assessing reliability and stability in panel models. *Sociological Methodology, 8*(1), 84-136. <https://doi.org/10.2307/270754>
- Yang, C., Nay, S., & Hoyle, R. H. (2010). Three approaches to using lengthy ordinal scales in structural equation models: Parceling, latent scoring, and shortening scales. *Applied Psychological Measurement, 34*(2), 122-142. <https://doi.org/10.1177/0146621609338592>
- Zakaria, N. (2011). *The influence of emotional and spiritual intelligence factors and social factors on the cognitive strategies of emotional self -regulation and social behavior of adolescents* [Unpublished doctoral dissertation]. Universiti Putra Malaysia.
- Zohar, D. (2005). Spiritually intelligent leadership. *Leader to Leader, 2005*(38), 45-51. <https://doi.org/10.1002/ltl.153>
- Zohar, D., & Marshall, I. (2000). *Spiritual intelligence the ultimate intelligence*. Bloomsbury Publishing Plc.