

# Measuring Social Relations in New Classroom Spaces: Development and Validation of the Social Context and Learning Environments (SCALE) Survey

J.D. Walker  
University of Minnesota

Paul Baepler  
University of Minnesota

This study addresses the need for reliable and valid information concerning how innovative classrooms on college and university campuses affect teaching and learning. The Social Context and Learning Environments (SCALE) survey was developed through a three-stage process involving approximately 1300 college students. Exploratory and confirmatory factor analyses supported a four-factor solution that measures formal and informal aspects of student-to-student as well as student-to-instructor classroom relations. The resulting 26-item instrument can be used by instructors to measure classroom social context in different types of learning spaces and to guide efforts to improve student outcomes.

## Introduction

Recent years have seen rapid growth in the design, development, construction, and use of new-style classrooms at institutions of higher education in North America and beyond (Oblinger, 2006; Finkelstein et al. 2010). This increased interest is evident in major classroom redesign projects at leading universities (e.g., the Mosaic Initiative at Indiana University, <https://uits.iu.edu/mosaic>; the Team-Based Learning Project at UMass Amherst, <http://innovate.umass.edu/team-based-learning-classrooms/>; the Active Learning Classrooms project at the University of Minnesota, <https://cei.umn.edu/support-services/tutorials/active-learning-classrooms>), and in the fact that active learning classrooms (ALCs) were named the top strategic technology of 2017 by the EDUCAUSE Center for Analysis and Research (<http://er.educause.edu/blogs/2017/3/active-learning-classrooms-the-top-strategic-technology-for-2017>).

In parallel with the development of new learning spaces, a growing body of research has emerged that examines the changes brought about in the teaching-learning process by holding classes in these new classrooms. Some studies have found that, compared to near-identical classes taught in traditional classrooms, teaching a class in an active learning classroom yields improvements in both student affective responses and in student learning outcomes

(Brooks, 2010; Walker, Brooks & Baepler, 2011; Baepler, Walker & Driessen, 2014); other studies have yielded null results (Stoltzfus & Libarkin, 2016). What has been studied less often than the outcomes associated with different types of learning spaces are the possible *mechanisms* that underlie those outcomes. If new classrooms do affect teaching and learning, by what means do they do so?

The purpose of this study is to contribute to answering this question by conceptualizing how learning spaces shape the teaching-learning process, focusing in particular on changes to the social aspects of learning. From a theoretical point of view, the contribution of this study is to break down the social aspects of classroom learning into clear, distinct dimensions as well as to provide a reliable and valid way of measuring those dimensions. Practically speaking, this study validates a simple self-report instrument that can be used by instructors to gauge the social components of a class and to guide efforts to promote the most educationally constructive of those components.

## Literature Review

We came to the idea of social context through our early research on ALCs (Whiteside, Brooks, & Walker, 2010). In a series of focus group interviews, we asked instructors and students who had taught or taken classes in ALCs what was different about these learning spaces; a common theme was that ALCs changed the social aspects of class, primarily through their physical layout. That the ALCs had no single focal point to draw attention seemed to influence instructors and students so that they interacted with each other more frequently than in a lecture hall - from instructors threading

---

J.D. Walker, Center for Educational Innovation,  
University of Minnesota.

Paul Baepler, Center for Educational Innovation,  
University of Minnesota.

through the student tables asking and answering questions to students facing one another and conversing.

The idea that social context may be an important component of the educational process is bolstered by the fact that it has received substantial attention in the area of educational theory focusing on interpersonal relationships in the classroom (Amedeo, Golledge & Stimson, 2009; Meyers, 2008; Tiberius & Billson, 1991).

Conceptually, social context has affinities with related concepts such as academic engagement, but it is not the same as engagement. In an educational context, engagement is typically thought of as a kind of involvement in the educational process and it is almost always conceptualized as having multiple dimensions with the most common being behavioral, affective, and cognitive (Appleton, 2008; Fredericks *et al.*, 2004). Accordingly, students are said to be engaged when they behave in certain ways (attend class, participate in class-related activities, etc.); when they have certain sorts of feelings (of belonging, of enjoyment, of identification with academic pursuits, etc.); and when they have certain types of beliefs and thoughts (perceiving that subject matter is interesting, worthwhile, etc.) (Jimerson, Campos & Greif, 2003). Moreover, engagement is usually conceived as having a positive association with academic achievement, including learning outcomes as well as completion, persistence, time to degree, etc. (Appleton *et al.*, 2006; Christenson & Thurlow, 2004).

Social context, as we think of it, differs from engagement in its essentially interpersonal nature. Depending on the theory, student engagement may or may not include a social component, whereas social context consists of the network of inter-relationships in the classroom, between instructors and students as well as among students themselves. In fact, social context may help to determine how engaged students are in the educational process, and if so, it should be conceptualized and measured separately. This observation becomes particularly relevant when we conceive of how classroom space affects learning. A classroom that facilitates social interaction may affect student engagement, and possibly learning outcomes, differently than a traditional classroom that does not invite the same social connections.

## Methodology

### *Item generation*

In preparing to design items, we reviewed our existing data on social interaction in the classroom. We consulted transcripts of interviews with instructors, recordings of student focus groups, formal observation logs, and responses to hundreds of open-ended survey questions from both instructors and students. Additionally, we reviewed

the educational literature on working alliances and social context. From this initial review we developed 63 items that mapped to constructs we identified in our data and in the literature. Our aim was to capture the spectrum of social interactions among students and instructors as it might manifest both inside and outside the classroom. All of the items conformed to guidelines for writing effective questionnaire items that minimize measurement error (Dillman, 2014).

We sought content validity by reviewing items with four researchers and conducting three think-aloud interviews with students. As a result of these procedures, we eliminated items that were deemed not to express an aspect of social relations. For instance, the item “I am responsible for my own learning” only implicitly involves a social connection and was thus removed. We also revised ambiguous wording when it arose in the think-aloud. For example, students considered the item “I know the instructor as a person” to indicate a high level of connection that was rarely if ever achieved; however, students felt that they more frequently became “acquainted” with an instructor, so we revised that item to reflect that nuance. Additionally, because our plan was to make comparisons between traditional classroom seating arrangements and the more flexible configurations of the ALCs, we eliminated any mention of “groups” or “partners” and opted for references to students “sitting near me.” This change makes the SCALE survey agnostic with respect to the type of learning environment in which it is implemented and ideal for making comparisons between room types.

### *Pilot test: Exploratory factor analysis*

The item-generation process resulted in a survey that contained 31 items measured on an agree/disagree scale; we administered this survey to 842 introductory science students at the University of Minnesota in 2015. To explore the underlying dimensions in the data, we conducted an exploratory factor analysis using principal components analysis (PCA). We chose PCA because it attempts to explain as much of the total variance in an observed data set as possible, using a set of latent factors. We chose an oblique rotation (oblimin with Kaiser normalization) because we expected the factors to be correlated.

Following recommendations from Costello *et al.* (2005), we used Kaiser’s criterion (Eigenvalues greater than one), the shape of the scree plot, and substantive interpretability to determine how many components to retain from the analysis. The initial PCA yielded 5 factors using Kaiser’s criterion, but the fifth of these factors contained just two items and had an Eigenvalue of only 1.030, while the scree plot showed a distinct drop in plotted Eigenvalues between factors 4 and 5. These two items were therefore removed

from the analysis. Furthermore, two additional items were removed because their factor loadings were below .40 and hence were too low for practical significance (Netemeyer, Bearden, & Sharma, 2003).

A second PCA with oblimin rotation was conducted on the remaining 27 items. The Kaiser-Meyer-Olkin measure of sampling adequacy was acceptable (KMO = .929), Bartlett's test of sphericity was significant ( $\chi^2 = 10259.86, p < .000$ ), and all criteria recommended retaining 4 factors which together explained 58.21% of variance in the data set. Some researchers suggest that PCA and factor-analytic techniques like principal axis factoring (PAF) will yield similar results if the data set does not contain excessive measurement error (Costello, 2005; Teo, 2013), therefore another analysis was run on the remaining 27 items, using PAF with oblimin rotation. This analysis produced a 4-factor solution nearly identical to the one obtained from the PCA, indicating low measurement error in the data.

The 4-factor solution divides into two broad categories: two factors describe student interactions with each other and 2 factors outline the connection between the student and instructor. Factor 1 (Student-Student General Relations) comprised 10 items pertaining to whether the respondent knew other students in the class and had learned from them. Factor 2 (Student-Instructor Formal Relations) contained 5 items that focused on more formal aspects of class, like asking questions during class, taking tests or handling assignments. Five items made up factor 3 (Student-Instructor Informal Relations) and had to do with mutual acquaintance between students and instructor. Finally, the 7 items in factor

4 (Student as Instructor) all pertained to the respondent's playing the role of instructor with respect to his or her fellow students.

All of the factors had reliability coefficients greater than .7, and none could attain greater reliability by removing any of their constituent items. Correlations between the factors were positive, significant at the  $p < .01$  level, and only moderate in size (ranging from .208 to .526), indicating that the 4 factors are sufficiently independent to contribute separately to the overall structure of the data.

*Validation: Confirmatory factor analysis*

In 2016, we administered the 27-item, 4-factor SCALE survey to 344 introductory science students at the University of Minnesota and subjected the resulting data set to confirmatory factor analysis using AMOS 24.0 in order to validate the factor solution that had emerged from the PCA. We began by examining the Mardia's skewness and kurtosis coefficient to determine whether our data were multivariate normally distributed and hence appropriate for structural equation modeling. Raykov & Markoulides (2008) suggest that the Mardia's coefficient should be less than  $(\# \text{ of indicators}) * (\# \text{ of indicators} + 2)$ ; in our data set, and this value =  $27 * 29 = 783$ . The Mardia's coefficient for our data was 123.962, substantially less than 783, so we proceeded with the analysis.

(Table 1 shows the four-factor solution along with reliability coefficients for each factor; the full list of items retained at this stage, along with factor loadings for each item, is provided in Appendix 1.)

**Table 1. Four-factor solution for measuring social context**

	<b>Factor 1: Student-Student General Relations</b>	<b>Factor 2: Student-Instructor Formal Relations</b>	<b>Factor 3: Student-Instructor Informal Relations</b>	<b>Factor 4: Student as Instructor</b>
<b>Reliability (<math>\alpha</math>)</b>	.915	.727	.847	.835
<b>Eigenvalue</b>	8.82	3.26	2.25	1.39
<b>Percent variance explained</b>	32.66	12.06	8.34	5.15
<b>Items</b>	Q1, Q8, Q9, Q14, Q15, Q21, Q24, Q25, Q26, Q27	Q3, Q6, Q11, Q17, Q22	Q5, Q10, Q12, Q18, Q20	Q2, Q4, Q7, Q13, Q16, Q19, Q23
<b>Sample item</b>	Q21: I am acquainted with the students sitting near me in class.	Q11: My instructor wants me to do well on the tests and assignments in this class.	Q20: I've spoken informally with the instructor before, during, or after class.	Q4: The people sitting near me have learned something from me this semester.

Because the four factors had been found to be correlated in the exploratory stage, the latent variables representing those factors were assumed to covary in the confirmatory model. Further, the SCALE survey items were examined and the items that were substantively related to one another were also allowed to covary in the confirmatory model (Blunch, 2013). Each indicator variable was associated with exactly one latent factor, and indicator variables associated with one latent factor were not permitted to covary with indicators associated with a different latent factor.

We report here several measures of model fit. Because the  $\chi^2$  statistic associated with structural equation models is too strongly influenced by sample size, we report the normed  $\chi^2/df$  ratio, where the range of desirable ratios is between 2 and 5 (Carmines & McIver, 1981; Marsh & Hocevar, 1985), with lower ratios indicating better model fit. We also report the absolute index of fit RMSEA (good fit indicated by values close to .05), and two incremental fit indices, namely the comparative fit index CFI, and the Tucker-Lewis Index, with desirable values above .90 (Hu & Bentler, 1999).

The initial CFA indicated moderate model fit ( $\chi^2$  705.028,  $\chi^2/df$  ratio 2.335, CFI .913, TLI .899, RMSEA .062). One item (Q10) was removed because it was implicated in many of the modification indices produced by AMOS and was associated with several standardized residual covariances above 3. (This item also had a relatively low factor loading and cross-loaded substantially on more than one factor in the exploratory stage.) After removing this item, all indicators of model fit improved:  $\chi^2$  583.642,  $\chi^2/df$  ratio 2.11, CFI .929, TLI .917, RMSEA .057.

We compared two alternative models to our 4-factor, 26-item model: first, an uncorrelated or null model, and second, a 2-factor model that conceptualized all 26 items into two dimensions, namely a student-student factor and a student-instructor factor. The fit indices for all three models are shown in Table 2. The results suggest that the 4-factor model fits the data best.

Model	$\chi^2$	$\chi^2/df$	CFI	TLI	RMSEA
Uncorrelated	1008.790	3.172	.851	.836	.079
Two-factor	1330.469	4.334	.778	.747	.099
Four-factor	583.642	2.11	.929	.917	.057

The graphical representation of the 4-factor SCALE instrument is shown in Figure 1, in the form of a path diagram.

*Discussion*

The purpose of this study was to examine the psychometric properties of an instrument designed to measure different aspects of classroom social context. The

results provided support for the validity and reliability of the 26-item SCALE survey, which conceives of social context as consisting of four distinct dimensions, two having to do with student-student relations and two with student-instructor relations. Little cross-loading of items was found in the exploratory stage. The dimensions of social context were correlated positively and significantly but only moderately, suggesting that the dimensions measure distinct aspects of social context. The SCALE survey can be used by instructors teaching in different types of learning spaces to measure the ways in which space affects the social aspects of the teaching-learning process.

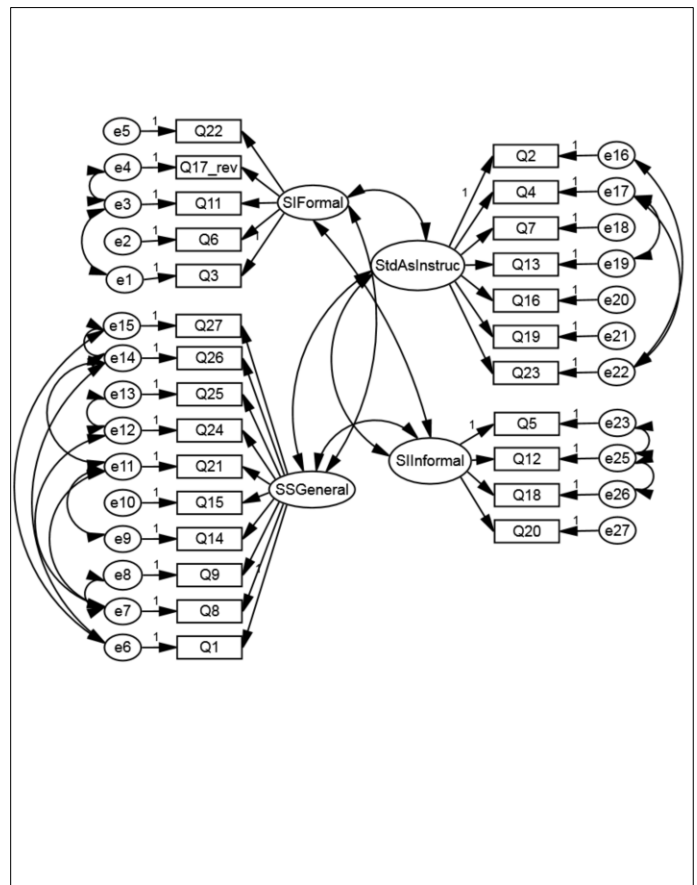

Figure 1. Path model of the 4-factor SCALE instrument

This study was based on data derived from a relatively large sample of college students (over 800 in the exploratory stage and nearly 350 in the confirmation stage), but its conclusions are limited by the fact that our participant population was relatively homogeneous in age and ethnicity all of whom were enrolled at a large, urban, Midwestern university. Further validation of the SCALE survey could extend its application to graduate students, to smaller colleges, to more diverse student populations, etc.

In an attempt to map the connections between the four dimensions of social context and the learning outcomes that students achieve research currently underway at our university will apply the SCALE survey to live classroom contexts. Through this new study we hope to answer two questions that are crucial to establishing the importance of social context in the study of new learning spaces: (1) Is social context as measured by the SCALE survey different in different types of learning spaces (e.g., ALCs vs lecture halls) (2) Does social context matter to student learning. If the answer to both of these questions is yes, then social context may be a plausible mechanism underlying the impact that different learning spaces have on teaching and learning. Not only would this result expand our theoretical understanding of how learning spaces work, but from a practical point of view, it would also suggest ways for instructors to support their students' learning by working to improve the social context in their classrooms.

---

## References

- Amedeo, D., R. G. Golledge, and R. J. Stimson. (2009). *Person environment behavior research: Investigating activities and experiences in spaces and environments*. New York, NY: Guilford.
- Appleton, J. J., Christenson, S. L., Kim, D., & Reschly, A. L. (2006). Measuring cognitive and psychological engagement: Validation of the Student Engagement Instrument. *Journal of School Psychology, 44*, 427 – 445.
- Appleton, J. J., Christenson, S. L., & Furlong, M. J. (2008). Student engagement with school: Critical conceptual and methodological issues of the construct. *Psychology in the Schools, 45*(5), 369-386.
- Baepler, P., Walker, J.D. & Driessen, M. (2014). It's not about seat time: Blending, flipping, and efficiency in active learning classrooms. *Computers & Education, 78*, 227-236. <http://www.sciencedirect.com/science/article/pii/S0360131514001390>.
- Blunch, N. (2013). *Introduction to Structural Equation Modeling Using IBM SPSS Statistics and AMOS*. Thousand Oaks, CA: Sage.
- Brooks, D. C. (2011). Space matters: The impact of formal learning environments on student learning. *British Journal of Educational Technology, 42*, 719–726.
- Carmines, E.G. & McIver, J. P. (1981). Analyzing models with unobserved variables: Analysis of covariance structures. In George W. Bohrnstedt, & Edgar F. Borgatta (Eds.), *Social measurement: Current issues* (pp. 65–115). Beverly Hills, CA: Sage.
- Christenson, S. L., & Thurlow, M. L. (2004). School dropouts: Prevention considerations, interventions, and challenges. *Current Directions in Psychological Science, 13*, 36 – 39.
- Costello, A.B., & Osborne, J.W. (2005). Best practices in exploratory factor analysis: Four recommendations for getting the most from your analysis. *Practical Assessment, Research & Evaluation, 10*, 1-9.
- Dillman, D. A., Smyth, J. D., & Christian, L. M. (2014). *Internet, phone, mail, and mixed-mode surveys: The tailored design method*. John Wiley & Sons.
- Finkelstein, A., Weston, C., Tovar, M., & Ferris, J. (2010). Designing and supporting active learning classrooms. Anaheim, CA: EDUCAUSE.
- Fredericks, J. A., Blumenfeld, P. C., & Paris, A. H. (2004). School engagement: Potential of the concept, state of the evidence. *Review of Educational Research, 74*, 59 – 109.
- Gerbing, D.W., & Anderson, J.D. (1992). Monte Carlo evaluations of goodness of fit indices for structural equation models. *Sociological Methods & Research 21*, 132-160.
- Hu, L., & Bentler, P. M. (1999). Cutoff criteria for fit indexes in covariance structure analysis: Conventional criteria versus new alternatives. *Structural Equation Modeling, 6*, 1-55.
- Jimerson, S. R., Campos, E., & Greif, J. L. (2003). Toward an understanding of definitions and measures of school engagement and related terms. *California School Psychologist, 8*, 7 – 27.
- Marsh, H.W. & Hocevar, D. (1985). Application of confirmatory factor analysis to the study of self-concept: First- and higher order factor models and their invariance across groups. *Psychological Bulletin, 97*, 562–582.
- Meyers, S. A. (2008). Working alliances in college classrooms. *Teaching of Psychology, 34*, 29–32. <http://www.tandfonline.com/doi/abs/10.1080/00986280701818490>
- Netemeyer, R., Bearden, W., & Sharma, S. (2003). *Scaling procedures: Issues and applications*. Thousand Oaks, CA: Sage.

- Oblinger, D.G. (Ed.). (2006). *Learning spaces*. Boulder, CO: EDUCAUSE. Raykov, T. & Marcoulides, G.A. (2008). An introduction to applied multivariate analysis. New York: Routledge.
- Stoltzfus, J.R. & Libarkin, J. (2016). Does the room matter? Active learning in traditional and enhanced lecture spaces. *CBE—Life Sciences Education*, 15(4), 1-10.
- Taylor, G., Jungert, T., Mageau, G. A., Schattke, K., Dedic, H., Rosenfield, S., & Koestner, R. (2014). A self-determination theory approach to predicting school achievement over time: The unique role of intrinsic motivation. *Contemporary Educational Psychology*, 39(4), 342–358.  
<http://doi.org/10.1016/j.cedpsych.2014.08.002>
- Teo, T. (2013). An initial development and validation of a Digital Natives Assessment Scale (DNAS). *Computers & Education*, 67, 51-57.
- Tiberius, R. G., and J. M. Billson. (1991). The social context of teaching and learning. In *College Teaching: From Theory to Practice, New Directions in Teaching and Learning*, no. 45, edited by R. Menges and M. Svinicki, 67–86. San Francisco: Jossey-Bass.
- Walker, J.D., Brooks, D.C., & Baepler, P. (2011). Pedagogy and space: Empirical research on new learning environments. *EDUCAUSE Quarterly*, 34(4), no pagination. Online at <https://er.educause.edu/articles/2011/12/pedagogy-and-space-empirical-research-on-new-learning-environments>
- Whiteside, A.W., Brooks, D.C. & Walker, J.D. (2010). Making the case for space: Three years of empirical research on formal and informal learning environments. *EDUCAUSE Quarterly*, 33(3), no pagination. Online at: <https://er.educause.edu/articles/2010/9/making-the-case-for-space-three-years-of-empirical-research-on-learning-environments>

## Appendices

### Appendix 1: Full list of SCALE items with factor loadings

(All questions answered on a 5-point scale from “Strongly Agree” to “Strongly Disagree”)

Item	Factor loading	Factor
Q1: I’ve learned something from my classmates.	.750	<b>Factor 1: Student-Student General Relations</b>
Q8: The students sitting near me rely on each other for help in learning class material.	.751	
Q9: In general, the people sitting near me in class work well together on class assignments, questions, etc.	.821	
Q14: I know something personal about the people sitting near me in class.	.747	
Q15: I feel comfortable asking for help from my classmates.	.679	
Q21: I am acquainted with the students sitting near me in class.	.838	
Q24: During class, I often have a chance to discuss material with some of my classmates.	.718	
Q25: The students sitting near me respect my opinions.	.611	
Q26: Other students pointed out a helpful resource.	.663	
Q27: Other students explained a concept to me.	.866	
Q3: The material covered by the tests and assignments in this class was presented and discussed in class or online.	.536	<b>Factor 2: Student-Instructor Formal Relations</b>
Q6: My instructor makes class enjoyable.	.579	
Q11: My instructor wants me to do well on the tests and assignments in this class.	.498	
Q17: Sometimes I feel like my instructor and I are on opposing teams in this class.	-.719	
Q22: My instructor encourages questions and comments from students.	.638	

MEASURING SOCIAL RELATIONS IN NEW CLASSROOM SPACES

Q5: The instructor knows my name.	.775	<b>Factor 3: Student-Instructor Informal Relations</b>
Q10: The instructor seems to care about me. <b>(Question removed in the CFA stage)</b>	.489	
Q12: The instructor is acquainted with me.	.864	
Q18: I am acquainted with the instructor.	.835	
Q20: I've spoken informally with the instructor before, during, or after class.	.771	
Q2: I can explain my ideas in specific terms.	.696	<b>Factor 4: Student as Instructor</b>
Q4: The people sitting near me have learned something from me this semester.	.560	
Q7: I can clearly explain new concepts I've learned to others in class.	.714	
Q13: I can persuade my classmates why my ideas are relevant to the problems we encounter in this class.	.484	
Q16: I can use the terminology in this class correctly.	.708	
Q19: I can explain my thought process from start to finish to others in class.	.818	
Q23: I can help others in this class learn.	.600	<b>Questions removed from the instrument in the EFA stage</b>
The instructor is often amusing.		
I know at least one thing about the instructor that is unrelated to the course.		
My instructor is approachable.		
I respect my instructor.		