

# Relationship Between Teacher ICT Competency And Teacher Acceptance And Use Of School Management System (SMS)

Leong Mei Wei[1], Chua Yan Piaw [2], Sathiamoorthy Kannan [3], Shafinaz A. Moulod [4]

[1] Institute of Educational Leadership, University of Malaya  
lmw5098@gmail.com

[2] Institute of Educational Leadership, University of Malaya

[3] Institute of Educational Leadership, University of Malaya

[4] Institute of Educational Leadership, University of Malaya

## ABSTRACT

This study aims at examining the relationship between teacher ICT competency and teacher acceptance and use of SMS in Negeri Sembilan secondary schools in Malaysia. This is a non-experimental quantitative research using survey technique through the administration of a set of questionnaire that comprised teacher demographic variables, teacher ICT competency and teacher acceptance and use of SMS. Some 417 returned questionnaires have been analyzed. The findings showed that teachers in Negeri Sembilan secondary schools rated themselves as having high level of ICT competency, and acceptance and use of SMS. Furthermore, data indicated that there was a statistically significant moderately strong positive correlation between teacher ICT competency and teacher acceptance and use of SMS. In addition, multiple regression analysis showed that smart pedagogy, professional growth and leadership, and digital citizenship were the three teacher ICT competency dimensions that are statistically significant predictors of teacher acceptance and use of SMS. The fitness indexes of the proposed structural model do not achieve the level of fitness required for RMSEA, GFI, and Ratio Chisq/df. Thus, a re-specified structural model was established for this study.

**Keywords:** *ICT Competency, ICT Acceptance, ICT Use*

## INTRODUCTION

Globalization and the advancement of information and communications technology (ICT) have created a new knowledge-driven economy era and brought intense competitiveness in the workplace (Haughey, 2006). Consequently, many governments have started to invest heavily in ICT to address the demands of this digital information age (Ministry of Education Malaysia, 2010). The progress of web-based technology together with the exponential growth of Internet accessibility has enabled widespread usage of web-based applications across many different disciplines (Avci Yucel & Gulbahar, 2013). The prominent role of ICT could be seen in advancing knowledge and as a necessary skill for effective functioning in the modern world (Adeyemi & Olaleye, 2010; Trilling & Fadel, 2009). Hence, the educated workforce is vital to remain competitive because the state of the education system today is the best predictor of Malaysia's competitiveness tomorrow (Ministry of Education Malaysia, 2013b).

Educational technology has altered the instructional landscape (Papa, 2011) and significantly changed the Malaysian educational system (Wong, Mas Nida, Abu Daud, & Othman, 2011). In 1996, the Malaysian government launched the Multimedia Super Corridor (MSC) to accelerate its entry into the Information Age as the major national initiative to transform Malaysia into a knowledge-based society with ICT advancement

in line with the country's ambitions in achieving fully developed status by 2020. Smart School, one of the seven flagships under the MSC aimed at integrating ICT into the school environment to equip the next generation to become more competitive in the technology-driven globalized world (Hamsha, 2011). Now, the new 'ICT in Education' concept has a broader notion and it operates in a grander scheme as compared to the 'Smart School' initiative. The broader concept includes amalgamating multilateral efforts from all stakeholders, from the Ministry of Education (MOE) level to the school and educational institution level, and especially the Community of Practice which consists of experienced teachers, industry practitioners, alumni, parents and students who can provide constructive feedback on user requirements and areas of improvement to solidify the approach of integrating ICT in education (Ministry of Education Malaysia, 2010). MSC Malaysia would identify and support the development of niche areas in software and e-solutions, creative multimedia, shared services, outsourcing and e-business in the 10th Malaysia Plan 2011–2015 (The Economic Planning Unit of Prime Minister's Department, 2010).

Moreover, the Interim Strategic Plan 2011-2020 (Ministry of Education Malaysia, 2012b), also strongly emphasized ICT use in schools or educational institutions as a prerequisite for Malaysia to become a high income nation to achieve the 10th Malaysia Plan 2011-2015 objectives. To achieve the objectives mentioned, MOE has launched a comprehensive education system review in order to develop a new National Education Blueprint in October 2011 (Ministry of Education Malaysia, 2012a). The Blueprint offers a vision of education system and students' aspirations that Malaysia both needs and deserves, and 11 strategic or operational shifts required to achieve that vision have been suggested. Among these 11 strategic shifts, shift seven is related to the leverage of Information and Communications Technology (ICT) to scale up quality of learning across Malaysia which provides Internet access and virtual learning environment via 1-BestariNet for all 10,000 schools. Furthermore, Clause 29 & 30 in the National Education Policy effort from the Educational Policy Planning and Research Division (2012) also clearly reflected the needs of the educational system in Malaysia to use ICT in teaching and learning and educational management.

School systems have access to more data than ever before but most teachers and school leaders are lacking in skills to use the data for student and school improvement (Murray, 2013). Hussein (2013) stated that there appears to be lack of coordination among Malaysian educational agencies that routinely collect some amount of the same school-related information. This practice has tended to create duplication in data collection, raising issues of questionable data reliability and extra burden to schools. Thus, he suggests that a more comprehensive, detailed and related information system that can digest, assimilate, interpret and use with full effectiveness is necessary to overcome this weakness. Besides, the information system should highlight integration of management, administration and operations that will be required in terms of the principal alliances and the channels of communication across divisions and units, states, districts and schools. His suggestion is in line with one of the eight key focus area covered under the Policy on ICT in Education (Ministry of Education Malaysia, 2010) to have a central Educational Management System.

Following this, a new School Management System (SMS) was launched by the Education Technology Division, Ministry of Education in 2013. SMS is a simplified and resourcefully integrated system with can accomplish many management tasks (Haslina, Bahbib, & Norhisham, 2014). The main objective of this system is to create only one information management application for all schools to reduce teachers' burden and to create a centralized database that can be utilized and reached by multiple users or all agencies under the MOE. This system automates two key function areas which are: (i) school management and educational administration and (ii) teaching and learning (Ministry of Education Malaysia, 2013a). School administrators and teachers used the SMS to manage schools' information, whereas, at the same time parents, Ministry of Education staff and even students can access relevant information from the SMS.

According to Madiha Shah (2014), the online information system usage in educational management has increased rapidly due to its effectiveness and efficiency; the main purpose and usage of school management system was to improve the efficiency of school activities in terms of storing students' and teachers' personnel data. Furthermore, the overall literature review highlighted the positive impact of school management system on school management and administration which includes more efficient administration, better time management, higher utilization of school resources, reduction in workload, better accessibility to information, and improvement in the quality of reports. Thus, technology includes all scientific techniques and processes for improving work and to be an effective user of technology, it is

important for the school teachers to understand how technological advances could affect the effectiveness of school management (Munro, 2008). In other words, teachers are the driving force to ensure effective utilization of SMS in school management. However, teachers need to have the necessary skills or competencies to perform this task. Hence, this study was carried out to examine the relationship between teacher ICT competency and teacher acceptance and use of SMS in Negeri Sembilan secondary schools.

### PROBLEM STATEMENT

Mounting pressure from other sectors to produce computer-literate graduates, and fear that our students will be ill prepared for participating in the knowledge-based economy without good computer skills, is pushing the Malaysian government to invest more heavily in computer technology over the five decades since independence (Ministry of Education Malaysia, 2012a). However, the gap between the high levels of expenditure on educational technology and the expected return in school improvement is still a global education agenda with great debate (Leong, 2010; Lu, 2013; Wahdain & Ahmad, 2014). Moreover, continuous efforts are being taken to enhance teachers' ICT skill in all schools in the Malaysian context (Sathiamoorthy, Leong, & Mohd Jamil, 2011), but the ICT usage in schools does not meet the expected requirement both in terms of quantity and quality (Fong, Ch'ng, & Por, 2013). This indicates that the investment and policies in getting teachers to embed the use of ICT have not been found to be helpful by teachers (Haydn & Barton, 2008).

Chen (2004) and Wachira and Keengwe (2011) found that despite the proliferation of computer equipment provided in the school and the promise of educational technologies, survey of teachers consistently showed declines in educational technology usage. Based on a MOE study finding in 2010, only one third of students perceive their teachers to be using ICT regularly in their teaching process and about 80% of teachers are found to spend less than one hour a week using ICT even though ICT has tremendous potential to accelerate the learning process. However, this potential has not yet been achieved (Ministry of Education Malaysia, 2012a).

Furthermore, based on the Feedback on The Auditor General's Report 2013, Series 3 (Ministry of Finance, 2014), the level of Virtual Learning Environment (VLE) usage among Malaysian teachers is very low, in the range of 0.57% to 4.69%. This issue of low and slow uptake of technology among teachers brings us to one very pertinent question: What can be done to ensure that teachers do and want to accept and use technology in carrying out their routine duties as teachers?

Liew (2007) found that most teachers may not be in favor of the ICT program because they lack competency in dealing with ICT. Is this the main cause of low level of ICT usage among teachers? According to Hamsha (2011), adopting ICT competency standards and adequate training will help teachers to incorporate ICT effectively in education. Besides, it is also commonly acknowledged that ICT is expanding rapidly; if teachers are not ready with adequate and latest knowledge and skills, they would be unable to keep pace with the ever-changing technology and inevitably will be left behind and hampered from mastering new ICT competencies (Mas Nida, Wong, & Ayub, 2011). Hence, a paradigm shift needed to maximize the potential of ICT and its application is very much expected in the minds of the teachers and the concerned authority that is in charge of preparing the teachers to keep abreast of rapid ICT development (Sathiamoorthy et al., 2011). So, in order to prepare teachers to use technology effectively, we need to identify the current level of teacher ICT competency; in other words, how teachers perceived their own ICT competency.

Even though ICT usage has been proven able to improve organizational effectiveness and productivity, the human factor is identified as the most important determinant for the success or failure of ICT implementation (Wahdain & Ahmad, 2014). Besides teacher ICT competency, teacher acceptance and use of ICT are another vital elements (Ministry of Education Malaysia, 2010). Information system has played a significant role in education management, but resistance to its usage by public school teachers worldwide remains high (Hu, Clark, & Ma, 2003). Liew (2007) assumed that one of the main factors that might hinder ICT program implementation could be teachers' resistance to the acceptance and use of this new technology in school and this will cause the huge investment into SMS development to be wasted. So, in order to properly and effectively implement SMS in our public school system, teachers need to have positive attitudes and confidence in using this SMS that will motivate them to integrate it into their routine work. In other words, teachers' attitudes and beliefs about SMS usage will significantly influence their acceptance and use of SMS

in their routine work. Thus, it is important to study teachers' level of acceptance and use of SMS to ensure efficient and effective school management in Negeri Sembilan. Furthermore, the researcher aims to examine the relationship between teacher ICT competency and teacher acceptance and use of SMS in Negeri Sembilan secondary schools.

### RESEARCH OBJECTIVES

This study aims at investigating teachers' perception of their level of ICT competency and acceptance and use of SMS in Negeri Sembilan secondary schools. The objectives of this study are as follows:

1. To analyze the level of teacher acceptance and use of SMS (endogenous variable) in Negeri Sembilan secondary schools.
2. To analyze the level of teacher ICT competency (exogenous variable) in Negeri Sembilan secondary schools.
3. To examine the relationship between teacher ICT competency and teacher acceptance and use of SMS in Negeri Sembilan secondary schools
4. To analyze which of the teacher ICT competency dimensions are the significant predictors of teacher acceptance and use of SMS in Negeri Sembilan secondary schools.
5. To evaluate if the proposed structural model involving teacher ICT competency and teacher Acceptance and use of SMS fit with the data collected from Negeri Sembilan secondary schools.

### CONCEPTUAL FRAMEWORK

This study investigates teacher ICT competency as the endogeneous (dependent) variable in relation to teacher acceptance and use of SMS as the exogeneous (independent) variable. The formulation of the conceptual framework for this study was based on Vroom's (1964, 1995) expectancy motivation theory that motivation is a product of the individual's expectancy that a certain effort will lead to the intended performance. This was further supported by Parijat and Bagga (2014) who stated that motivation is the driving force behind all human efforts and it is essential to their performance. Hence, as applied to this study, this theory holds that if teachers possess ICT competency as their effort to perform any task by using the SMS, teachers will be motivated to accept and use SMS to carry out their routine work. The conceptual framework of the study are as shown in Figure 1.

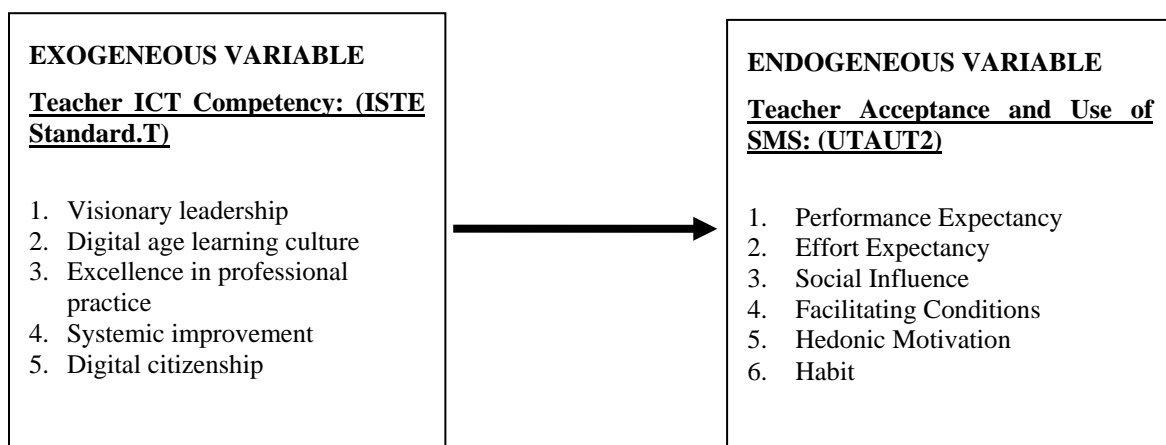

**Figure 1. Conceptual framework of the study.**

### LITERATURE REVIEW

Teacher ICT competency has been viewed as a prerequisite for the acceptance and use of ICT in school systems (Archibong, Ogbiji, & Anijaobi-Idem, 2010). According to Rogers (2003), individuals' decision to accept and use a new technology is related to the skills and knowledge one has regarding how to operate that technology (information system) appropriately. Based on the Jegede, Dibu-Orjerinde, and Illori (2007)

empirical study, the finding indicated that there was a significant positive relationship ( $r = .663, p < .05$ ) between ICT competence and the general computer attitudes and practices of an individual.

In line with the Jegede et al. (2007) study, Sa'ari, Wong, and Roslan (2005a) also found that teachers who demonstrated high level of competency in using computers find information systems to be more useful. These teachers approached the information system with greater confidence and displayed a lower level of anxiety and aversion to using it. Besides, the results showed that there was a weak positive correlation ( $r = .127, p < .05$ ) between teachers' attitudes and their perceived competence toward computer usage (Sa'ari, Wong, & Roslan, 2005b). Therefore, the researchers argued that being competent in using computers is also an important asset rather than only having positive attitudes toward information system usage. This showed that both attitudes and ICT competency played a significant part in establishing the concrete development of teacher acceptance and use of information system. In other words, to enhance teacher acceptance and information system use, there is an urgent need for the teachers to acquire the right attitude with a higher competency level for the betterment of the information system application in the education system.

Based on another study conducted by Ting (2007) to investigate the level of ICT usage among 181 teachers from four secondary schools in the Sarikei District, Sarawak, Malaysia, the researcher found a moderate significant positive correlation ( $r = .42, p < .01$ ) between teacher ICT competency with teacher's level of ICT usage. This positive relationship revealed that teachers with a higher level of ICT competency will demonstrate a higher level of ICT application.

Next, another study conducted by Lau and Sim (2008) further clarified that teachers who are more competent in using ICT have reported more favorable perception toward the acceptance and ICT use in Malaysian secondary schools. Hence, the authors suggested that to develop their ICT competency teachers' perception must change and their ICT usage must increase. This result is consistent with the findings of the previous study which concluded that teachers who are more competent in using computers also have more favorable attitudes toward computers (Jegede et al., 2007; Sa'ari et al., 2005b; Varol, 2013).

Afshari, Kamariah, Wong, Foo, and Bahaman (2009) took the final data of 320 Iranian secondary school principals to examine the extent to which they used computers, their perceived computer competency and leadership styles. The study findings showed that principals' computer competence and transformational leadership contributed significantly to their level of computer use. The Pearson product-moment correlation coefficient showed a significant positive strong relationship between their level of computer use with their computer competency ( $r = .74, p < .05$ ). This finding implies that level of computer use would be improved when computer use competency were enhanced. In other words, the higher level of computer use is often caused by an increase in computer competence. Furthermore, the strong, positive relationship between computer use and computer competence suggests that establishing regular programs for improving principals' competence would help to improve their level of computer use for instructional and administrative purposes. Computer competence explained 54% of the variance in the level of computer use. This finding made computer competence an important factor that can be taken into consideration when examining the level of computer use.

Integration of ICT into classroom instruction for meaningful learning has been a challenging task worldwide (Chai, 2010). Chai (2010) conducted a study to investigate the relationships among Singaporean pre-service teachers' ICT competencies, pedagogical beliefs, and their beliefs about ICT acceptance and use. The data were collected from 1,230 pre-service teachers who enrolled in teacher preparation programs at the National Institute of Education, which is the sole teacher education institute in Singapore. The findings affirmed that the pre-service teachers' ICT competencies and their pedagogical beliefs are significantly related to their acceptance and use of ICT. These findings suggested that basic ICT competencies underpin teachers' ICT use in their instruction. However, based on the path analysis, pedagogy-oriented ICT competency does not yield any significant paths toward ICT use. The researcher found that this might be because the construct is targeted toward general pedagogy such as classroom management and the adaptation of existing electronic resources for teaching. Hence, he suggested that a more specific survey related to a clear theoretical orientation should be further explored.

Based on the NETS.T (2000) performance indicators prescribed by ISTE, Hsu (2010) developed two scales to measure teachers' self-perceived technology integration competency and usage. The data were

collected from 3,729 Taiwanese teachers. The results of Pearson correlation showed a significant moderate positive correlation ( $r = .56, p < .001$ ) between teachers' technology integration competency and usage. This finding suggests that teachers with high competency in technology integration generally show higher usage of technology integration in their daily work.

Based on a survey conducted by Buabeng-Andoh (2012a) to examine teachers' competency, perceptions, and practices toward ICT usage in second-cycle institutions in Ghana, the correlation analysis showed a positive significant correlation ( $r = .68, p < .01$ ) between teachers' ICT use and their ICT competence. This result is consistent with Sorgo, Verckovnik, and Kocijancic (2010), who found a high correlation between teacher ICT competency with the frequency of use of ICT and perceived importance of ICT among Biology teachers. They concluded that teacher ICT competency and confidence were predictors of ICT usage in teaching.

In contrast, Drent and Meelissen (2008) found that teachers' ICT competence has no direct influence on their innovative ICT usage. However, we found that the teachers' ICT competence defined by these researchers is only the basic computer skills and knowledge regarding how to operate the computer and software; it was more appropriate to focus on the end-user ability to apply ICT in carrying out routine tasks. Hence, in this study, we aim at studying teacher ICT competency in terms of skill and knowledge as an educator in teaching, working and learning processes based on the ISTE Standard.T (2008).

Based on the literature discussed, the majority of studies reported a significant relationship between teacher ICT competency with teachers' application or acceptance and use of ICT (Buabeng-Andoh, 2012b; Chai, 2010; Hsu, 2010; Lau & Sim, 2008; Sorgo et al., 2010; Ting, 2007) and teachers' attitude toward computers (Jegade et al., 2007). Although teacher ICT competency has been viewed as a prerequisite for ICT acceptance and use in school systems (Archibong et al., 2010), not many empirical studies reported on the relationship between teacher ICT competency and teacher acceptance and use of School Management Systems. Hence, in this study, we expect that teacher ICT competency would influence teacher acceptance and use of SMS. In other words, we would like to examine the relationship between teacher ICT competency and teacher acceptance and use of SMS in Negeri Sembilan secondary schools.

## METHODOLOGY

### (A) Research Design

This study aimed at examining the relationship between teacher acceptance and use of SMS as the endogenous variable with teacher ICT competency as the exogenous variable. Thus, quantitative research method is applied to explain how one variable affects another (Creswell, 2014) or to establish relationship between variables (Fraenkel, Wallen, & Hyun, 2011). This is a non-experimental quantitative research using survey technique by administering a set of questionnaires developed for data collection. A cross-sectional and self-administered questionnaire was the data collection tool for this research design.

### (B) Population and Sample of the study

The targeted population for this study comprised all public secondary day school teachers in Negeri Sembilan, Malaysia. There are 6499 teachers within 89 schools located at six different districts in Negeri Sembilan. The minimum number of respondents needed for this study at the significance level  $p = .05$  is 362 teachers (Krejcie & Morgan, 1970). Sample selection for this study was conducted in several stages by probability sampling procedure involving proportional stratified random sampling, simple random sampling and systematic random sampling. A total of 450 questionnaires were distributed to the respondents and a total of 417 questionnaires collected were analyzed, representing a valid response rate of 92.7%.

### (C) Instrument

A questionnaire was developed by the researchers to obtain the information needed for the study. The instrument comprised of respondent demographic variables, teacher ICT competency, and teacher acceptance and use of SMS. Teacher demographic variables are gender, age group, teaching experience,

highest educational level, and experience in using computers.

Teacher ICT competency was measured according to ISTE Standards for Teachers (ISTE Standards•T) as prescribed by ISTE (2008). ISTE Standards•T is a standard for evaluating the skills and knowledge which educators need to teach, work and learn in an increasing connected global and digital society. These standards consist of five dimensions which are: (i) Smart Pedagogy; (ii) Digital age learning experiences and assessments; (iii) Digital age work and learning; (iv) Digital citizenship and responsibility; and (v) Professional growth and leadership. Besides, the researcher also adapted some of the ICT competency standards for Malaysian Science and Mathematics teachers developed by a group of researchers using Delphi technique (Fong et al., 2013).

Teacher acceptance and use of SMS scale was adapted from the Unified Theory of Acceptance and Use of Technology (UTAUT2) Model (Venkatesh, Thong, & Xu, 2012), consisting of six dimensions: (i) Performance Expectancy; (ii) Effort Expectancy; (iii) Social Influence; (iv) Facilitating Condition; (v) Hedonic Motivation; and (vi) Habit.

The developed instrument was pilot tested on 57 secondary school teachers in some secondary schools located in the states of Selangor, Perak and Johor. Data gathered were analyzed using the Statistical Packages for the Social Sciences (SPSS) version 22.0 for internal consistency. The results of analysis showed that the Cronbach alpha for the teacher ICT competency dimensions were between .800-.929, and teacher acceptance and use of SMS dimensions were in the range of .843-.926. These indicated that the instrument achieved a good level of reliability.

#### **(D) Analysis of Data**

Numerical data gathered were analyzed quantitatively using SPSS and Analysis of Moment Structures (AMOS) version 22.0. Both descriptive and inferential statistical methods were used to analyze the data to answer the proposed research questions. Descriptive statistics in terms of mean and standard deviation were used to answer the first two research questions. Inferential statistics, the Pearson product-moment correlation test was performed to examine the relationship between teacher ICT competency and teacher acceptance and use of SMS. Inferential statistics, the multiple regression analysis was carried out to identify which dimensions of teacher ICT competency contribute to the changes in the teacher acceptance and use of SMS. Finally, structural equation modelling (SEM) procedure with AMOS was carried out to evaluate whether the data collected fit with the proposed model of teacher ICT competency and teacher acceptance and use of SMS in Negeri Sembilan secondary schools.

## **FINDINGS**

This section presents the results of the study according to each of the research questions.

### **The Level of Teacher Acceptance and Use of SMS in Negeri Sembilan Secondary Schools**

Descriptive statistics were used to analyze the data collected from 417 teachers in Negeri Sembilan secondary schools. The analysis yielded results as shown in Table 1.

**Table 1: Mean, Standard Deviation and the Level of Teacher Acceptance and Use of SMS (N = 417)**

Dimension	Mean	Standard Deviation	Level
1) Performance Expectancy	7.03	1.49	High
2) Effort Expectancy	7.00	1.46	High
3) Social Influence	6.55	1.42	Medium
4) Facilitating Conditions	7.23	1.34	High
5) Hedonic Motivation	6.86	1.51	High
6) Habit	6.45	1.71	Medium
Overall	6.85	1.32	High

Based on Table 1, the overall mean for teacher acceptance and use of SMS is 6.85. This could be interpreted as high level of teacher acceptance and use of SMS in Negeri Sembilan secondary schools. The results of the analysis for each of the teacher acceptance and use of SMS dimensions indicated that four out of six of the teacher acceptance and use of SMS dimensions showed high level of mean. These dimensions are performance expectancy, effort expectancy, facilitating conditions, and hedonic motivation. The other two of the teacher acceptance and use of SMS dimensions namely social influence and habit demonstrated medium level of mean.

#### **The Level of Teacher ICT Competency in Negeri Sembilan Secondary Schools**

The descriptive analysis for level of teacher competency yielded results as shown in Table 2.

**Table 2: Mean, Standard Deviation and the Level of Teacher ICT Competency (N=417)**

Dimension	Mean	Standard Deviation	Level
1) Smart Pedagogy	7.42	1.19	High
2) Digital Age Learning Experience and Assessments	7.28	1.21	High
3) Digital Age Work and Learning	7.39	1.14	High
4) Digital Citizenship and Responsibility	7.19	1.23	High
5) Professional Growth and Leadership	6.87	1.21	High
<b>Overall</b>	<b>7.19</b>	<b>1.08</b>	<b>High</b>

As shown in Table 2, the overall mean for teacher ICT competency is 7.19. This could be interpreted as high level of teacher ICT competency in Negeri Sembilan secondary schools. The results of the analysis for each of the teacher ICT competency dimensions indicated that three out of the five teacher ICT competency dimensions have higher mean than the overall mean. These dimensions are Smart Pedagogy, Digital Age Learning Experience and Assessments, and Digital Age Work and Learning. Digital Citizenship and Responsibility dimension has similar mean as the overall mean of teacher ICT competency, while the other dimension, Professional Growth and Leadership showed lower mean than the overall mean of teacher ICT competency. However, all the five teacher ICT competency dimensions have means that are interpreted as high level. These means that the respondents rated themselves as demonstrating high level of competence for all the five teacher ICT competency dimensions in Negeri Sembilan secondary schools.



### Relationship between Teacher ICT Competency and Teacher Acceptance and Use of SMS in Negeri Sembilan secondary schools

The Pearson product-moment correlation test was performed to examine the relationship between principal technology leadership practices and teacher acceptance and use of SMS. The result of the analysis was presented in the following Table 3.

**Table 3: Pearson Product-Moment Correlation Analysis between Teacher ICT Competency and Teacher Acceptance and Use of SMS**

Variable		Teachers' Acceptance and Use of SMS
Teacher ICT Competency	Pearson Correlation	.634**
	Sig. (2-tailed)	.000
	N	417

\*\* . Correlation is significant at the 0.01 level (2-tailed)

Table 3 showed that for the sample of this study ( $n = 417$ ), there is a statistically significant positive correlation which is moderately strong ( $r = .634$ ,  $p < .01$ ) between teacher ICT competency and teacher acceptance and use of SMS.

### Effects of Teacher ICT Competency on Teacher Acceptance and Use of SMS in Negeri Sembilan Secondary Schools

The multiple regression analysis yields outputs as shown in Table 4.

**Table 4: Multiple Regression (Stepwise) on Teacher ICT Competency to Teacher Acceptance and Use of SMS (N = 417)**

Variable	(Unstad.) B	(Stand.) B	t	Sig	R <sup>2</sup>	Contribution (%)
Smart Pedagogy	.368	.330	5.762	.000	.349	34.9
Professional Growth and Leadership	.248	.226	3.716	.000	.397	4.8
Digital Citizenship and Responsibility	.159	.148	2.315	.021	.405	0.8
Constant	1.274		3.781	.000		

The result of multiple regression analysis shown in Table 4 indicated that the prediction model contained three out of the five predictors. These predictors are smart pedagogy ( $\beta = .330$ ,  $p = .000$ ), professional growth and leadership ( $\beta = .226$ ,  $p = .000$ ), and digital citizenship and responsibility ( $\beta = .148$ ,  $p = .021$ ). Smart pedagogy dimension (model 1) was found to contribute 34.9% of the variance in teacher acceptance and use of SMS ( $R^2 = .349$ ), the combination of smart pedagogy, and professional growth and leadership dimension (model 2) accounted for 39.7% of the variance in teacher acceptance and use of SMS ( $R^2 = .397$ ) while the combination of smart pedagogy, professional growth and leadership, and digital citizenship and responsibility dimension (model 3) accounted for 40.5% of the variance in teacher acceptance and use of SMS ( $R^2 = .405$ ).

The dominant predictor for teacher acceptance and use of SMS is smart pedagogy dimension of the teacher ICT competency ( $\beta = .330$ ,  $t = 5.762$  and  $p = .000$ ). The  $t$ -test result was significant at the significant level of  $p < .05$  with the  $R^2 = .349$ , this indicated that smart pedagogy dimension contributes 34.9% of the variance in teacher acceptance and use of SMS. Based on the standardized beta value, when the smart pedagogy dimension of the teacher ICT competency increased by one unit of standard deviation, teacher acceptance and use of SMS increased by .330 unit of standard deviation.

The second predictor which contributed 4.8% of the variance in teacher acceptance and use of SMS is professional growth and leadership dimension ( $\beta = .226, t = 3.716$  and  $p = .000$ ). The  $t$ -test result was significant at the significance level  $p < .05$  with the combined  $R^2 = .397$ , this indicated that the professional growth and leadership dimension contributes 4.8% (39.7% - 34.9%) of the variance in teacher acceptance and use of SMS. Based on the standardized beta value, when the professional growth and leadership dimension of the teacher ICT competency increase by one unit of standard deviation, teacher acceptance and use of SMS will increase by .226 unit of standard deviation.

The third predictor which contributed only 0.8% of the variance in teacher acceptance and use of SMS is digital citizenship and responsibility dimension ( $\beta = .148, t = 2.315$  and  $p = .021$ ). The  $t$ -test result was significant at the significance level  $p < .05$  with the combined  $R^2 = .405$ , this indicated that the digital citizenship and responsibility dimension contributes 0.8% (40.5% - 39.7%) of the variance in teacher acceptance and use of SMS. Based on the standardized beta value, when the digital citizenship and responsibility dimension of the teacher ICT competency increase by one unit of standard deviation, teacher acceptance and use of SMS will increase by .148 unit of standard deviation.

**Table 5: Multiple Regression Analysis (Stepwise): ANOVA**

	Sum of Squares	df	Mean Square	F	Sig.
Regression	294.726	3	98.242	93.697	.000
Residual	433.035	413	1.049		
Total	727.761	416			

Based on Table 5, the  $F$ -test result indicated that there is a significant relationship between the three predictor variables with teacher acceptance and use of SMS [ $F(3,413) = 93.697, p = .000$ ] at the significance level of  $p < .05$ . This multiple regression analysis results also showed that the combination of the three dimensions of teacher ICT competency – smart pedagogy, professional growth and leadership, and digital citizenship and responsibility accounted for 40.5% of the variance in teacher acceptance and use of SMS. This means that as much as 59.5% of the variance in teacher acceptance and use of SMS are unable to be predicted by teacher ICT competency as it may be caused by other variables (other factors) not examined in this study.

**Teacher ICT Competency and Teacher Acceptance and Use of SMS Model**

The primary task in this model-testing procedure is to determine the goodness-of-fit between the proposed model and the sample data (Byrne, 2010). The analysis yielded results as presented in Figure 2.

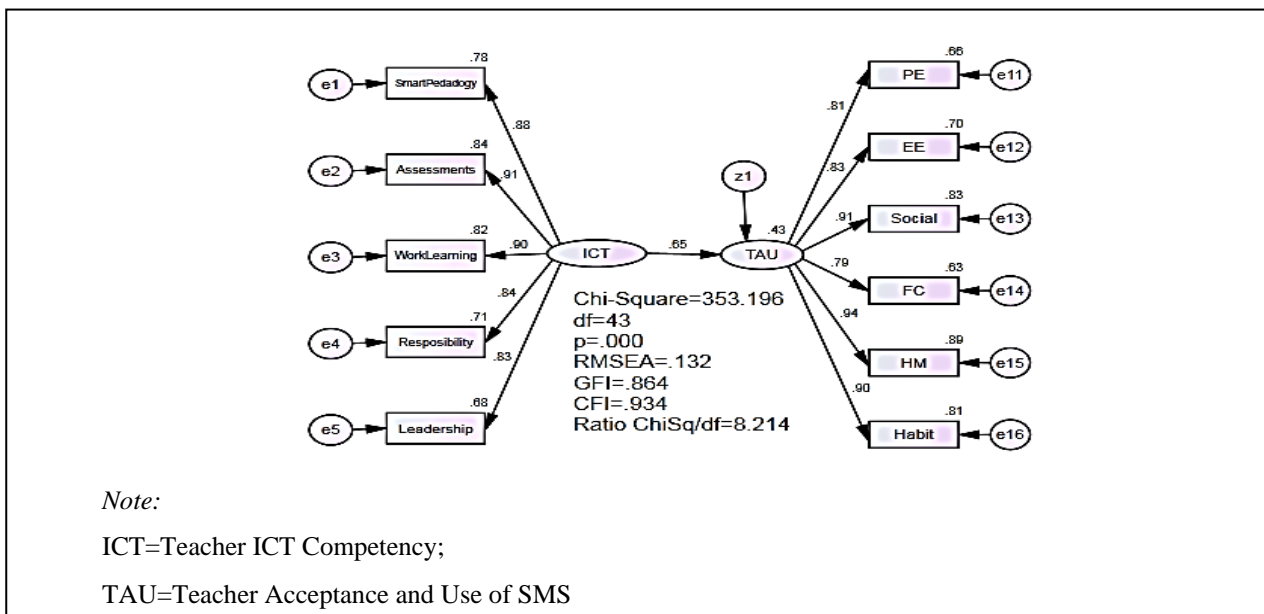

**Figure 2: The Proposed Structural Model.**

Figure 2 indicated that the fitness indices of the proposed structural model do not achieve the level of fitness required for RMSEA, GFI, and Ratio Chisq/df. According to Byrne (2010), the re-specification procedure is the model-generating scenario where the researcher, having postulated and rejected a theoretically derived model on the basis of its poor fit to the sample data, proceeds in an exploratory fashion to modify and re-estimate the model. The primary focus, in this instance, is to locate the source of misfit in the model and to determine a model that better describes the sample data. The ultimate objective is to find a model that is both substantively meaningful and statistically well fitting. Thus, based on the suggestion of the modification indices, a few of the measurement errors need to be set as “free parameter” to improve the model fitness. The measurement errors that need to be correlated are e1 with e2, e12 with e14, e14 with e15, and e15 with e16. The re-specified structural model is presented in Figure 3.

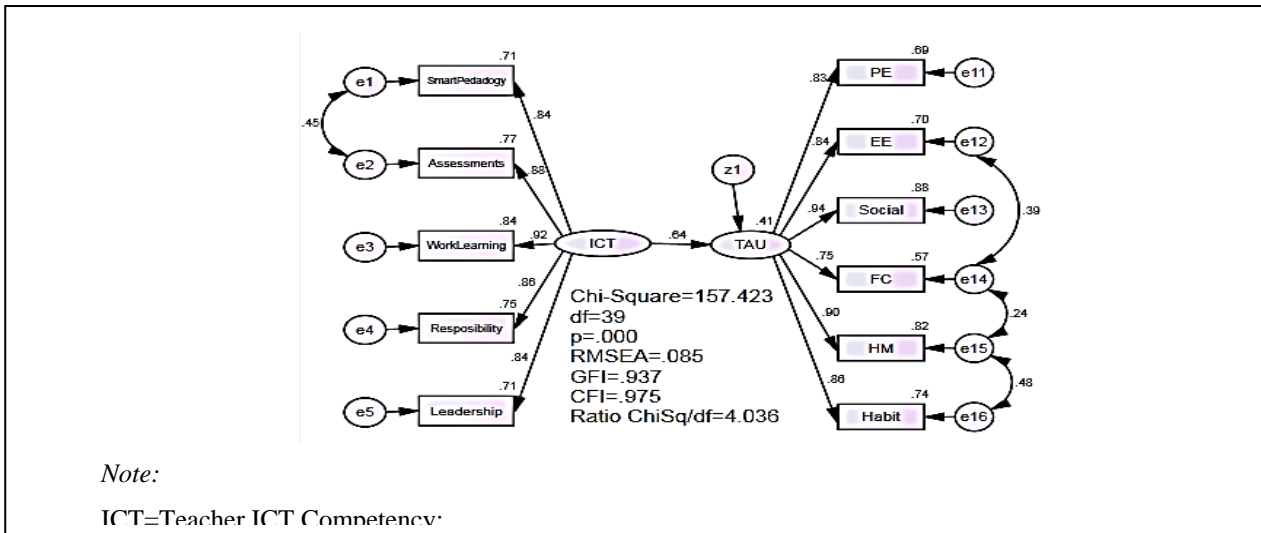

Figure 3. Re-Specified Structural Model

Based on the re-specified structural model shown in Figure 3, it was found that all the fitness indices have achieved the threshold values. This indicated that the re-specified structural model fit with the data collected from Negeri Sembilan secondary schools. The standardized beta value for the ICT→TAU is .64, indicating that when teacher ICT competency (ICT) increases by one standard deviation, teacher acceptance and use of SMS (TAU) would increase by .64 standard deviation. The squared multiple correlation for teacher acceptance and use of SMS (TAU) is .411. This indicated that 41.1% of the variance in teacher acceptance and use of SMS could be predicted by teacher ICT competency. This means that there are as many as 58.9% of the variance in teacher acceptance and use of SMS are unable to be predicted by teacher ICT competency as it may be caused by other variables (other factors) not examined in this study.

DISCUSSIONS

School is a complex organization with various functional roles and the information related to its community are overloaded (Kelly & Downey, 2011). Hence, ICT usage has been increasingly incorporated into school management to improve its effectiveness and efficiency (Madiha Shah, 2014; Prokopiadou, 2012). It was commonly acknowledged that the full utilization of SMS could offer invaluable support to schools, which are increasingly being granted autonomy in the school development policy (Bosker, Branderhorst, & Visscher, 2007). However, teachers need to have positive attitudes toward the acceptance and use of school management system (SMS) in order to properly and effectively integrate it into their routine work.

The results of this study indicated that teachers in Negeri Sembilan secondary schools demonstrated very positive attitudes toward SMS acceptance and use. This finding aligned with Albirini (2006), Demirci (2009), Teo (2008), and Pynoo and van Braak (2014) who also found that teachers’ positive attitude towards ICT is the key factor for enhancing teacher acceptance and use of ICT. Besides, this finding is also an excellent indicator of where these teachers have the confidence, desire and readiness to accept

and use SMS in carrying out their routine work. This was further supported by Madiha Shah (2014) who stated that the main objective of SMS is to implement and design the school's routine procedures and processes to provide suitable consistent, accurate and timely detailed reports. Thus, we concluded that information technology use in school management has shown some progress. In fact, it could be said that information system usage in school management is increasingly popular among teachers (Madiha Shah, 2014). Furthermore, these teachers found that performance expectancy, effort expectancy, facilitating conditions and hedonic motivation are more important factors regarding their acceptance and use of SMS compared with social influence and habit. This was supported by Wozney, Venkatesh, and Abrami (2006), who found that technology innovations are most likely to be accepted by teachers if the perceived value of the innovation usage and its expectancy of success are high. They revealed that perceived value of innovation usage and expectancy of success were the most crucial in differentiating teachers' computer acceptance and usage level.

Technology advancement has created a greater demand on teachers to engage with various types of technology in carrying out their routine work (Prokopiadou, 2012; Teo, 2015). Hence, in order to be effective, teachers should not only strive to improve their pedagogical knowledge and instructional skills, but they should constantly adapt to new technologies and refine their knowledge, skills and competencies in order to integrate instructional technology efficiently and effectively (Pynoo et al., 2011). Teacher ICT competency is the driving force toward achieving the goals of technology integration into the classroom (Varol, 2013). Besides, teacher ICT competency can be viewed as a form valuable national asset in terms of human resources which is important in promoting world-class education as outlined in Vision 2020. The results of this study indicated that teachers in Negeri Sembilan secondary schools showed high level of ICT competency for all the five dimensions of teacher ICT competency. This finding was consistent with the findings of Harin Hafian (2011), Tasir, Amin Abour, Abd Halim, and Harun (2012), and Umar and Mohd Yusoff (2014), who also found that Malaysian teachers demonstrated high level of ICT competency. The high level of teacher ICT competency could imply that various training programs implemented by the Malaysian government throughout the years have proved to be beneficial because the majority of the secondary school teachers who have attended them are more computer literate.

The Pearson product-moment correlation test showed that there is statistically significant positive and moderately strong correlation between teacher ICT competency and teacher acceptance and use of SMS. The positive correlation suggests that teachers with higher level of ICT competency will demonstrate higher level of acceptance and use of SMS. Hence, teacher ICT competency is confirmed as one of the factors influencing teacher acceptance and use of SMS. This was supported by the empirical study findings conducted by Buabeng-Andoh (2012a), Chai (2010), Hsu (2010), Jegede et al. (2007), Lau and Sim (2008), Sa'ari et al. (2005b), and Ting (2007), who found a significant relationship between teachers' ICT competency with their attitudes toward computers, level of computer usage, and more specifically, acceptance and use of ICT. This was further supported by Varol (2013) who stated that teacher ICT competency has been viewed as the critical factor that affects teachers' decision about their classroom practices.

Furthermore, based on the multiple regression analysis, it was found that smart pedagogy, professional growth and leadership, and digital citizenship and responsibility are the three teacher ICT competency dimensions that are statistically significant predictors of teacher acceptance and use of SMS in Negeri Sembilan secondary schools. This finding implies that the level of teacher acceptance and use of SMS will be increased when teachers are embedded with the use of ICT in their instructional practices, continuously strive to improve their professional practices by promoting and demonstrating effective use of ICT, and are concerned about the social, ethical and legal issues regarding ICT use among their students. This finding was in line with Franklin (2007), Knezek and Christensen (2002) and Varol (2013) who found that teacher ICT competency is the principal determinant to influence teacher effective use of ICT in their classroom practices; Sa'ari et al. (2005b) who found that teachers should be encouraged to create or design more technology-based activities, and share information and strategies dealing with instructional technology among their communities so that they will collectively gain a better understanding of the new digital era technology; and Raob, Al-Oshaibat, and Ong (2012) who stated that teachers must focus on safety, legal, and ethical behaviors as they pertain to instructional technology use. Hence in order to enhance teacher acceptance and use of SMS, there is a need to promote teacher ICT competency according to the dimensions

which have higher impact on teacher acceptance and use of SMS that emerged from the findings of this study.

Data analysis showed that the proposed structural model does not achieve the level of fitness required for some of the fitness indexes. This reflected that the proposed structural model does not fit well with the data collected from Negeri Sembilan secondary school teachers. Hence, a re-specified structural model, as shown in Figure 3 has been established.

## CONCLUSION

Technology has played an important role in schools around the world. Teachers and administrators are using technology in some aspect of their daily activities. According to Dede (2010), the twenty-first century seems to be very different if compared with the twentieth century in terms of skills and competencies people need to carry out their work and for their citizenship and self-actualization. In response to these, each society's educational system has to transform pedagogical objectives and curricula and assessment delivery for their students to help them to attain the excellent outcomes for a successful lifestyle reflected upon their effective contribution in the workplace and citizenship. Hence, the move to technology use is very much needed in order to engage this techno-savvy generation in their instructional process (Lewis, Fretwell, Ryan, & Parham, 2013).

In Malaysia, all public secondary schools are required to use School Management System (SMS) mandatory starting from 1st January 2015. Based on The Interim Strategic Plan 2011-2020 (Ministry of Education Malaysia, 2012b), this educational management system in the "Policy on ICT in Education" (Ministry of Education Malaysia, 2010) is the prerequisite for Malaysia to become a developed nation. The positive correlation between teacher ICT competency with teacher acceptance and use of SMS revealed that regular professional development to improve teacher ICT competency would help to enhance the level of acceptance and use of SMS. Hence, in order to enhance teacher acceptance and use of SMS, teachers need to acquire higher level of ICT competency for the betterment of school management by using SMS in Malaysian secondary schools. Besides, policy makers should design professional development programs to inculcate in teachers more effective and efficient ways to employ technology for learning as mentioned in shift seven of the Malaysia Education Blueprint (Ministry of Education Malaysia, 2012a).

## REFERENCES

- Adeyemi, T. O., & Olaleye, F. O. (2010). Information Communication and Technology (ICT) for the Effective Management of Secondary Schools for Sustainable Development in Ekiti State, Nigeria. *American-Eurasian Journal of Scientific Research*, 5(2), 106-113.
- Afshari, M., Kamariah, A. B., Wong, S. L., Foo, S. F., & Bahaman, A. S. (2009). Competency, leadership and technology use by principals. *The International Journal of Learning*, 16(3), 345-357.
- Albirini, A. (2006). Teachers' attitudes towards information and communication technologies: the case of Syrian EFL teachers. *Computer & Education*, 47, 373-398.
- Archibong, I. A., Ogbiji, J. E., & Anijaobi-Idem, F. (2010). ICT Cmpetence among Academic Staff in Universities in Cross River State, Nigeria. *Computer and Information Science*, 3(4), 109-115.
- Avcı Yucel, U., & Gulbahar, Y. (2013). Technology Acceptance Model: A review of the prior predictors. *Journal of Faculty of Educational Science, Ankara University*, 46(1), 89-109.
- Bosker, R. J., Branderhorst, E. M., & Visscher, A. J. (2007). Improving the utilisation of Management Information Systems in secondary schools. *School Effectiveness and School Improvement*, 18(4), 451-467. doi: 10.1080/09243450701712577
- Buabeng-Andoh, C. (2012a). An exploration of teachers' skills, perception and practices of ICT in

teaching and learning in the Ghanaian Second-Cycle schools. *Contemporary Educational Technology*, 3(1), 36-49.

Buabeng-Andoh, C. (2012b). Factors influencing teachers' adoption and integration of information and communication technology into teaching: A review of the literature. *International Journal of Education and Development using Information and Communication Technology*, 8(1), 136-155.

Byrne, B. M. (2010). *Structural Equation Modeling With AMOS: Basic concepts, applications, and programming* (2nd ed.). New York, NY: Taylor & Francis.

Chai, C. S. (2010). The relationships among Singaporean preservice teachers' ICT competencies, pedagogical beliefs and their beliefs on the espoused use of ICT. *Asia-Pacific Education Researcher*, 19(3), 387-400.

Chen, L.-L. (2004). Pedagogical strategies to increase pre-service teachers' confidence in computer learning. *Educational Technology & Society*, 7(3), 50-60.

Creswell, J. W. (2014). *Educational Research: Planning, Conducting, and Evaluating Quantitative and Qualitative Research* (4th ed.). Harlow, UK: Pearson.

Dede, C. (2010). Technological supports for acquiring Twenty-First-Century skills. In P. P. B. McGaw (Ed.), *International encyclopedia of education* (3rd ed.) (pp. 158-166). Oxford, UK: Elsevier.

Demirci, A. (2009). How do teachers approach new technologies: Geography teachers' attitudes towards Geographic Information Systems (GIS). *European Journal of Educational Studies*, 1(1), 43-53.

Drent, M., & Meelissen, M. (2008). Which factors obstruct or stimulate teacher educators to use ICT innovatively? *Computer & Education*, 51, 187-199.

Educational Policy Planning and Research Division. (2012). *National Education Policy, Ministry of Education*. Shah Alam, Malaysia: Giga Wise Network.

Fong, S. F., Ch'ng, P. E., & Por, F. P. (2013). Development of ICT Competency Standard using the Delphi Technique. *Procedia - Social and Behavioral Sciences*, 103, 299-314.

Fraenkel, J., Wallen, N., & Hyun, H. (2011). *How to design and evaluate research in education* (8th ed.). New York, NY: McGraw-Hill.

Franklin, C. (2007). Factors that influence elementary teachers use of computer. *Journal of Technology and Teacher Education*, 15(2), 267-293.

Hamsha, I. (2011). *Evaluation of Multimedia Super Corridor (MSC Malaysia) contribution in Malaysia economy*. (Master of Science, Ritsumeikan Asia Pasific University).

Harin Hafian, R. (2011). *Principals' transformational leadership on teachers' computer literacy at a Vocational Secondary School in Selangor*. (Unpublished Master's Thesis), University of Malaya, Kuala Lumpur.

Haslina, H., Bahbib, R., & Norhisham, M. N. (2014). Towards School Management System (SMS) success in teacher's perception. *Malaysian Online Journal of Educational Technology*, 2(4), 50-60.

Haughey, M. (2006). The impact of computers on the work of the principal: Changing discourses on talk, leadership and professionalism. *School Leadership & Management*, 26(1), 23-36. doi: 10.1080/13634230500492897

Haydn, T., & Barton, R. (2008). 'First do no harm': Factors influencing teachers' ability and willingness to use their subject teaching. *Computer & Education*, 51, 439-447.

Hsu, S. (2010). The relationship between teachers' technology integration ability and usage. *Journal of Educational Computing Research*, 43(3), 309-325.

Hu, P. J.-H., Clark, T. H. K., & Ma, W. W. (2003). Examining Technology Acceptance by School Teachers: A longitudinal study. *Information & Management*, 41, 227-241.

Hussein, A. (2013). *Mission of public education in Malaysia*. Kuala Lumpur: University of Malaya Press.

International Society for Technology in Education. (2008). ISTE Standards for Teachers.

Jegede, P. O., Dibu-Orjerinde, O. O., & Illori, M. O. (2007). Relationships between ICT competence and attitude among some Nigerian tertiary institution lecturers. *Educational Research and Review*, 2(7), 172-175.

Kelly, A., & Downey, C. (2011). Professional attitudes to the use of pupil performance data in English secondary schools. *School Effectiveness and School Improvement*, 22(4), 415-437.

Knezek, G., & Christensen, R. (2002). Impact of new information technologies on teachers and students. *Education and Information Technologies*, 7(4), 369-376.

Krejcie, R. V., & Morgan, D. W. (1970). Determining sample size for research activities. *Educational And Psychological Measurement*, 30, 607-610.

Lau, B. T., & Sim, C. H. (2008). Exploring The Extent of ICT Adoption Among Secondary School Teachers in Malaysia. *International Journal of Computing and ICT Research*, 2(2), 19-36.

Leong, M. W. (2010). *Principal Technology Leadership and The Level of ICT Application of Teachers at A Secondary School in Seremban District*. (Unpublished Master's Thesis), University of Malaya, Kuala Lumpur.

Lewis, C. C., Fretwell, C. E., Ryan, J., & Parham, J. B. (2013). Faculty Use of Established and Emerging Technologies in Higher Education: A Unified Theory of Acceptance and Use of Technology Perspective. *International Journal of Higher Education*, 2(2), 22-34.

Liew, V. K. (2007). ICT In Education: An Action Learning Approach using soft system methodology. *Educational Management and Leadership*, 17(2), 17-37.

Lu, H. Y. (2013). *Technology integration and pedagogical innovations in Malaysia Higher Education Institutions*. (Unpublished doctoral dissertation, University of Malaya, Kuala Lumpur.

Madiha Shah. (2014). Impact of management information systems (MIS) on school administration: What the literature says. *Procedia - Social and Behavioral Sciences*, 116, 2799-2804.

Mas Nida, M. K., Wong, S. L., & Ayub, A. F. (2011). Enhancing Teachers' Professional Development Through Laptops. In S. L. Wong, M. K. Mas Nida, S. Abu Daud & T. Othman (Eds.), *Technology & education: Issues, empirical research and applications*. Serdang: Universiti Putra Malaysia Press.

Ministry of Education Malaysia. (2010). *Policy on ICT in Education Malaysia*. Putrajaya: Ministry of Education.

Ministry of Education Malaysia. (2012a). *Executive Summary Malaysia Education Blueprint 2013-2025 (Preschool to Post-Secondary Education)*. Putrajaya, Malaysia: Author.

Ministry of Education Malaysia. (2012b). *Interim Strategic Plan 2011-2020*. Putrajaya, Malaysia: Author.

Ministry of Education Malaysia. (2013a). *Plans for the expansion of the implementation of School Management System as a solution in addressing teacher workload issues and an integrated educational data*. Putrajaya, Malaysia: Author.

Ministry of Education Malaysia. (2013b). *Malaysia Education Blueprint 2013-2025 (Preschool to post-secondary education)*. Putrajaya, Malaysia: Author.

Ministry of Finance. (2014). *Feedback on The Auditor General's Report, Series 3*. Putrajaya, Malaysia: Author.

Munro, J. H. (2008). *Roundtable viewpoints: Educational leadership* (1st ed.). New York, NY: McGraw-Hill.

Murray, J. (2013). Critical issues facing school leaders concerning data-informed decision-making. *School Leadership & Management*, 33(2), 169-177.

Papa, R. (2011). *Technology Leadership for School Improvement*. Thousand Oaks, CA: Sage.

Parijat, P., & Bagga, S. (2014). Victor Vroom's Expectancy Theory of Motivation: An evaluation.

*International Research Journal of Business and Management*, 7(9), 1-8.

Prokopiadou, G. (2012). Using Information and Communication Technologies in school administration: Researching Greek kindergarten schools. *Educational Management Administration & Leadership*, 40(3), 305-327.

Pynoo, B., Devolder, P., Tondeur, J., van Braak, J., Duyck, W., & Duyck, P. (2011). Predicting secondary school teachers' acceptance and use of a digital learning environment: A cross-sectional study. *Computers in Human Behavior*, 27, 568-575.

Pynoo, B., & van Braak, J. (2014). Predicting teachers' generative and receptive use of an educational portal by intention, attitude and self-reported use. *Computers in Human Behavior*, 34, 315-322. doi: <http://dx.doi.org/10.1016/j.chb.2013.12.024>

Raob, I., Al-Oshaibat, H., & Ong, S. L. (2012). A factor analysis of teacher competency in technology. *New Horizons in Education*, 60(1), 13-22.

Rogers, E. M. (2003). *Diffusion of Innovations* (5th ed.). New York, NY: Free Press.

Sa'ari, J. R., Wong, S. L., & Roslan, S. (2005a). Attitudes and perceived information technology competency among teachers. *Malaysian Online Journal of Instructional Technology*, 2(3), 70-77.

Sa'ari, J. R., Wong, S. L., & Roslan, S. (2005b). In-service teachers' views toward technology and teaching and their perceived competence toward Information Technology (IT). *Jurnal Teknologi*, 43(E), 1-14.

Sathiamoorthy, K., Leong, M. W., & Mohd Jamil, S. (2011). *Principal technology leadership and teachers' ICT applications in two different school settings in Malaysia*. Paper presented at the International Conference on Application of ICT in Economy and Education (ICAICTEE), UNWE, Sofia, Bulgaria.

Sorgo, A., Verckovnik, T., & Kocijancic, S. (2010). Information and Communication Technologies (ICT) in Biology teaching in Slovenian secondary schools. *Eurasia Journal of Mathematics, Science & Technology Education*, 6(1), 37-46.

Tasir, Z., Amin Abour, K. M. E., Abd Halim, N. D., & Harun, J. (2012). Relationship between teachers' ICT competency, confidence level, and satisfaction toward ICT training programmes: A case study among postgraduate students. *Turkish Online Journal of Educational Technology*, 11(1), 138-144.

Teo, T. (2008). Pre-Service teachers' attitudes towards computer use: A Singapore survey. *Australasian Journal of Educational Technology*, 24(4), 413-424.

Teo, T. (2015). Comparing pre-service and in-service teachers' acceptance of technology: Assessment of measurement invariance and latent mean differences. *Computers & Education*, 83(0), 22-31. doi: 10.1016/j.compedu.2014.11.015

The Economic Planning Unit of Prime Minister's Department. (2010). *Tenth Malaysia Plan 2011-2015*. Putrajaya, Malaysia: Author.

Ting, S. T. (2007). *ICT usage among teachers in the District of Sarikei secondary schools, Sarawak* (Unpublished Master's Thesis, University of Malaya, Kuala Lumpur).

Trilling, B., & Fadel, C. (2009). *21st Century Skills: Learning for life in our times* (First ed.). New York, NY: Wiley.

Umar, I. N., & Mohd Yusoff, M. T. (2014). A study on Malaysian teachers' level of ICT skills and practices, and its impact on teaching and learning. *Procedia - Social and Behavioral Sciences*, 116, 979-984.

Varol, F. (2013). Elementary school teachers and teaching with technology. *The Turkish Online Journal of Educational Technology*, 12(3), 85-90.

Venkatesh, V., Thong, J. Y. L., & Xu, X. (2012). Consumer Acceptance and Use of Information Technology: Extending The Unified Theory of Acceptance and Use of Technology. *MIS Quarterly*, 36(1), 157-178.

Vroom, V. H. (1964). *Work and motivation*. New York, NY: Wiley.



Vroom, V. H. (1995). *Work and motivation*. San Francisco, CA: Jossey-Bass.

Wachira, P., & Keengwe, J. (2011). Technology integration barriers: Urban school Mathematics teachers perspectives. *Journal of Scientific Educational Technology*, 20, 17-25.

Wahdain, E. A., & Ahmad, M. N. (2014). User acceptance of Information Technology: Factors, theories and applications. *Journal of Information Systems Research and Innovation*, 6, 17-25.

Wong, S. L., Mas Nida, M. K., Abu Daud, S., & Othman, T. (2011). *Technology & education: Issues, empirical research and applications* (1st ed.). Serdang, Malaysia: Universiti Putra Malaysia Press.

Wozney, L., Venkatesh, V., & Abrami, P. C. (2006). Implementing computer technologies: Teachers' perceptions and practices. *Journal of Technology and Teacher Education*, 14(1), 173-207.