

DOCUMENT RESUME

ED 458 139

SE 065 310

TITLE Proportionality: The X-Plane Generation. NASA Connect: Program 5 in the 1999-2000 Series.

INSTITUTION National Aeronautics and Space Administration, Hampton, VA. Langley Research Center.

REPORT NO EG-2000-02-04-LaRC

PUB DATE 2000-00-00

NOTE 24p.; Accompanying videotape not available through ERIC. For other documents in series, see SE 065 306-312.

PUB TYPE Guides - Classroom - Teacher (052)

EDRS PRICE MF01/PC01 Plus Postage.

DESCRIPTORS *Aerospace Technology; Astronomy; Elementary Education; *Geometry; Lesson Plans; Mathematics Activities; Mathematics Instruction; *Ratios (Mathematics); Science and Society; *Science Education; *Space Exploration; Space Sciences

IDENTIFIERS *Spacecraft

ABSTRACT

This teaching unit is designed to help students in grades 4-8 explore the concepts of scaling and proportion in the context of spacecraft design. The units in this series have been developed to enhance and enrich mathematics, science, and technology education and to accommodate different teaching and learning styles. Each unit consists of a storyline presenting the context for the problems to be solved, lists of the mathematics and science concepts addressed, background notes for the teacher, a list of teacher resources, and an activity complete with blackline masters. Also included are suggestions for extensions to the problems and their relationship to national mathematics standards. The story line for this unit is students learning why scaling and proportion are important factors in spacecraft design. (MM)



National Aeronautics and
Space Administration
Langley Research Center
Hampton, VA 23681-0001

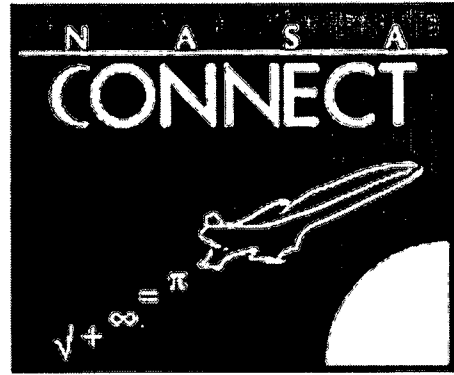

Program 5 in the 1999-2000 Series

ED 458 139

Proportionality: The X-Plane Generation

Story Line: Students will learn why scaling and proportion are important factors in spacecraft design.

Math Concepts: Computation, Ratios, Estimates, Measurement

Science Concepts: Systematic Investigation, Force, Motion, Energy, Heat, Sound

NASA Research: X-Planes
DFRC, LaRC, MSFC, STENNIS

U.S. DEPARTMENT OF EDUCATION
Office of Educational Research and Improvement
EDUCATIONAL RESOURCES INFORMATION
CENTER (ERIC)

- This document has been reproduced as received from the person or organization originating it.
- Minor changes have been made to improve reproduction quality.

Points of view or opinions stated in this document do not necessarily represent official OERI position or policy.

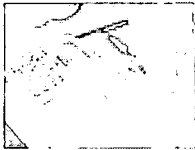

calculate ratios and proportions

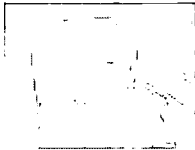

use the internet and visit Norbert's Lab

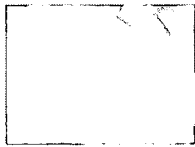

make your own model of NASA's X-33

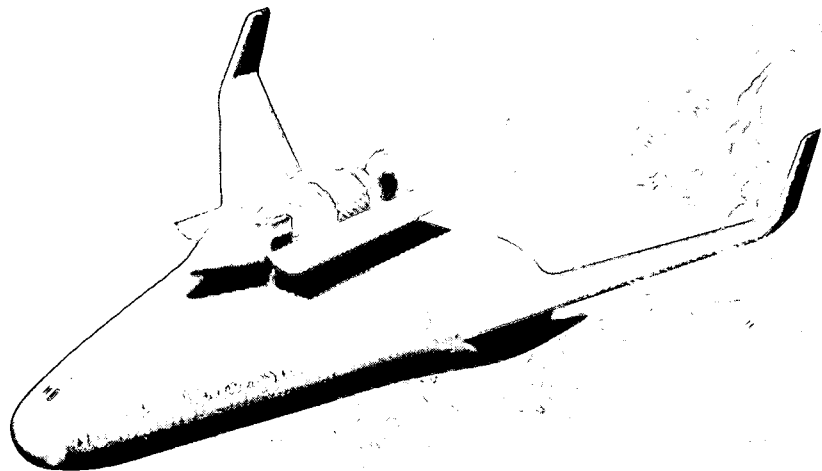

Educator's Guide	
Teachers & Students	Grades 4-8

Publication Number
EG-2000-02-04-LaRC

This publication is in the Public Domain and is not protected by copyright. Permission is not required for duplication.

Program 5
Proportionality: The X-Plane Generation

search

PROGRAM SUMMARY

OBJECTIVE

In Proportionality: The X-Plane Generation, students are introduced to the scale model as an engineering tool by using NASA's experimental aircraft, the X-33, as an example. Students may be familiar with scale models from toys, building kits, or from playing with dolls and dollhouses. This episode of NASA CONNECT focuses on the math concepts of computation, estimation, ratios, and measurement and illustrates a systematic scientific investigation. Students will meet NASA researchers and other professionals who will (a) describe the relationship between force, energy, and motion; (b) discuss how NASA's experimental X-plane is being tested to make space travel more reliable; (c) show students how proportionality and ratios are used to make scale models of spacecraft like the X-33; and (d) describe how scale models are more manageable than full-scale models when it comes to testing and retesting their designs.

CLASSROOM ACTIVITY

In this activity, students use the provided pattern to construct a paper scale model (1:140 scale) of the NASA X-33 experimental vehicle. Students will measure the linear dimensions of the model and, comparing those dimensions to the actual dimensions of the X-33, compute a scale factor. Demonstrating their understanding of the concept of proportionality, students may test whether the model is a true scale model. Finally, students use the scale model to estimate the volume of a "payload" that could fit inside the Lockheed-Martin Venture Star™. Optionally, advanced students may compare the surface area and volume of the scale model to the corresponding values for the full-scale X-33, discovering how area and volume scale factors relate to linear scale factors.

The suggested time schedule for the activity is based on a 45-minute teaching block:

- Day 1 Introductory information and construction of the X-33 model (1 hr.)
- Day 2 Find scale factor and use scale factor to determine the payload dimensions of the full-size and model X-33

For more information on *Proportionality: The X-Plane Generation*, visit the NASA CONNECT web site: edu.larc.nasa.gov/connect/xplane.html

WEB-BASED COMPONENT

Educators and students are invited to access *Kid's Corner Model Shop*, kidscorner.larc.nasa.gov/model_shop.html, the web-based component of *Proportionality: The X-Plane Generation*. *Kid's Corner Model Shop* offers activities centered around the construction and test-flying of model, paper airplanes. *The Model Shop* features three paper airplane model designs, a testing plan, and flight test data sheets. An added extension activity, *Model Shop Extra!*, challenges students to build one of the paper airplanes to a larger scale. *Model Shop Extra!* provides students with practical experience and questions involving ratios and proportions while introducing some of the unique problems associated with scaling. *The Kid's Corner Model Shop* also features information about and links to NASA wind tunnels, aerospace careers, model fabrication, and flight testing.

CAREER CORNER

Access to information is critical when making career decisions. *Career Corner*, located at edu.larc.nasa.gov/connect/xplane/norbert/lab.html features the individuals who appear in *Proportionality: The X-Plane Generation*. This web site includes pictures of the program participants, summaries of their duties and responsibilities, and details about a person, event, or situation that greatly influenced their career choice.

TEACHER BACKGROUND

X-33 AND VENTURESTAR™

In 1972 NASA engineers began work on the first reusable launch vehicle. They wanted to build a rocket that would work like a plane and carry satellites and people into space, orbit the Earth, reenter the atmosphere, and glide in for a runway landing. Nine years later, the Space Shuttle Orbiter *Columbia* roared off the launch pad at NASA's Kennedy Space Center. Since 1981, the Space Shuttle has been carrying astronauts, satellites, and science experiments into space.

The Space Shuttle is an engineering marvel, but it is expensive. It costs \$10,000 to carry a pound of payload into space. This price tag makes the Space Shuttle no more economical than unpiloted rockets that are used only once to carry satellites into orbit. The Space Shuttle also takes a long time to get ready for its next launch.

With a less expensive and faster way of getting into orbit, we could do more in space. For example, NASA's largest project in 1999 was building the International Space Station. The Space Station will orbit the Earth and provide a place for scientific research and medical experiments. Missions to other planets may leave from the Space Station. We will need a better and

less expensive way of getting to and from the Space Station. Just as lower airfares allow more people to fly, a less expensive launch vehicle could make it possible for people to work and even vacation in space. NASA engineers are now testing technologies that could be used to build a vehicle currently named VentureStar™ that could succeed the Space Shuttle. VentureStar™ would cost much less to operate and be ready to launch much faster than the Space Shuttle. It might cost only \$1000 to put a pound of payload into space on VentureStar™, and it could be ready to launch again only a few days after it lands.

As the first step in developing a new vehicle, NASA engineers (and their partners at Lockheed Martin, B. F. Goodrich, Boeing, AlliedSignal, and Sverdrup) are building a model called the X-33 that is half the size of VentureStar™. The X-33 will launch, but it won't carry people, a payload or actually go into orbit. It is designed as a "technology demonstrator" so that engineers can test the many new materials and technologies they will use on VentureStar™.

SUBSCALE MODELS

Engineers use subscale models for a variety of purposes:

- To simply get an idea of what the object looks like and to be able to communicate that to others
- To work with a design at a more manageable size
- To test a design less expensively, especially if the materials are costly
- To be able to change and re-test a design more easily
- To focus on one or a few aspects of a very complex system

The X-33 is a half-scale working model, a prototype, of VentureStar™. However, before engineers arrived at the stage of design when they could build a prototype, they performed tests using many smaller models. One model was used to test the aerodynamics of the lifting body design. With a lifting body, the body itself generates enough lift to eliminate the need for wings. Six-inch long scale models, about the size of the paper model in this lesson, built from plastic, with interchangeable parts, were tested extensively in wind tunnels. The plastic models can be made quickly and inexpensively. Next, an aluminum and stainless steel model of the X-33, about 15 inches long by 15 inches wide, was tested in a wind tunnel at a speed of Mach 0.25 (about 190 miles per hour at sea level). The same metal model was then tested in larger wind tunnels at higher speeds. Engineers also built a 1:25 scale radio-controlled flying model that could be released from a balloon. More information and movies of these tests are available at www.venturestar.com/pages/x33dem/external/aerodynamics.html.

NATIONAL MATH STANDARDS

- Communication
- Reasoning
- Connections
- Number and Number Relationships
- Mathematics as Problem Solving
- Computation and Estimation
- Patterns and Functions
- Geometry and Spatial Sense
- Measurement

NATIONAL SCIENCE STANDARDS

- Systematic Investigation
- Science and Technology

NATIONAL TECHNOLOGY STANDARDS

- Basic Operations and Concepts
- Technology Research Tools.

INSTRUCTIONAL OBJECTIVES

Students will

- learn what makes a model a "scale model" and discuss how engineers use models in research, design, development, and testing.
- construct a model of the X-33 Reusable Launch Vehicle (RLV) Technology Demonstrator using a provided pattern.
- use measurement tools (ruler, graph paper) and other techniques to determine the linear dimensions, area, and volume of the model.
- use the recorded measurements and the actual dimensions of the X-33 to determine scale factors for component parts of the model.
- use these scale factors to test that the model is proportional and, therefore, a "scale model."
- explore the effect of scaling on linear measurements.
- determine dimension of payload area of scale model.
- use the body height of the scale model to determine the volume of the payload bay.
- use calculators to compute scale factors, surface area, and volume.
- use the World Wide Web to access information.

TEACHER RESOURCES

Book/Article

Schmidt-Nielson, Knut: (1984) *Scaling, Why is Animal Size So Important?*
Cambridge University Press, UK.
Achenbach, Joel. (January, 2000). "Life Beyond Earth"
National Geographic: 24-51.

Wall Chart/Poster

Superstars of Modern Aeronautics: Your Attitude Determines Your Altitude
Series, EW-1998-07-126-HQ
Visit <http://spacelink.nasa.gov> (search this number and download file.)

Education Brief

International Space Station Crew Return Vehicle: X-38, EB-1998-11-127-HQ
Visit <http://spacelink.nasa.gov> (search this number and download file.)

Educators' Guides

Aeronautics: An Educator's Guide with Activities in Science, Mathematics,
and Technology Education, EG-1998-09-105-HQ
Visit <http://spacelink.nasa.gov> (search this number and download file.)
Rockets: A Teacher's Guide with Activities in Science, Mathematics, and
Technology, EG-1996-09-108-HQ
Visit <http://spacelink.nasa.gov> (search this number and download file.)

Videos

Powers of 10, Pyramid Film and Video (1978)

Test Flights Beyond the Limits Series (1999)

Target: Grades 7-Adult

Available through NASA CORE, <http://core.nasa.gov>

These films present an entertaining and compelling story of the world of flight tests and research. Three 47-minute programs combine exciting aerial footage of unique research aircraft and insight interviews with pilots and engineers to tell the inspiring and sometimes dangerous story of flight research.

- Program 1: *Flights of Discovery*

From the X-15 to testing of the new X-33 engine, learn what drives NASA's modern-day explorers to go beyond tragedy, to find answers, and to push the edges of flight where no one has gone before.

- Program 2: *The Need for Speed*

Witness how pilots and crews meet the challenges of supersonic flight with planes such as the X-1 and SR-71 and explore the new technologies of the X-43 and the High-Speed Civil Transport, which may open a new world of unprecedented speed.

- Program 3: *The New Frontier*

Experience how current computer technology is changing how we fly. From the radical looking X-29 to the amazing thrust vectoring X-31, explore how computer developments can improve safety and deliver undreamed of performance.

Web Sites

Marshall Space Flight Center's X-33 Web Site

x33.msfc.nasa.gov

Marshall Space Flight Center's Space Transportation Web Site

highway2space.com

The VentureStar™ Web Site

www.venturestar.com/

Marshall Space Flight Center X-33 Images Gallery

x33.msfc.nasa.gov/x33gallery/x33gallery.html

Norbert's Lab on the NASA CONNECT Web Site

edu.larc.nasa.gov/connect/x-plane/lab/html

Beginner's Guide to Aerodynamics Index

www.grc.nasa.gov/WWW/K-12/airplane/short.html

Beginner's Guide to Propulsion Index

www.grc.nasa.gov/WWW/K-12/airplane/shortp.html

PlaneMath: A place to learn cool things about math and aeronautics

www.planemath.com

Exploring Aeronautics

exploringaerospace.arc.nasa.gov

THE ACTIVITY: MODELING THE X-33

BEFORE THE ACTIVITY

1. Hold a discussion of models with students. Explain that they will be working with models and should look around home for toys that are models of full-size objects. Have students bring in models such as toy cars, dolls, doll furniture, scientific toys, and model airplanes. Select one or a few of the models to discuss. Here are some ideas you may wish to include:

- Models represent the "real things." For each of the toy models, ask what full-size object the model represents.
- Models usually differ in size from the real thing. Sometimes the model is larger, sometimes smaller than the real thing it models. Ask students for examples of models that are larger than the real thing (a model of a cell, a model of an atom) and models that are smaller than the real thing (a globe, a model of the Sun). Record examples on the board or poster paper.

Estimate the size of the toy models in relation to the full-size object. Ask students to estimate the scale of one of the models. Is it half-scale, quarter-scale, tenth-scale, hundredth-scale? Help students understand that two types of data are needed to determine the scale factor: the size of the model and the size of the "real thing." Show how to write the scale of a model in the form 1:20. Explain that this is a ratio and is the same as $1/20$. Estimate the scale factor for other models.

2. Ask what the scale would be if you doubled the size of one of the toys. (You may need to clarify what you mean by "double.") If you did double the size, how would that change the height, the width, or the length? (It is not recommended that you discuss changes in surface area or volume at this point.) What would be the scale of the new model?

Models show only selected features of the real thing. Ask students whether the toy models represent every aspect of the full-size object or only some aspects. Using several of the toy models, discuss what features of the full-size object are represented in the model (shape, color, texture), and what features are not represented (internal structure). Why would the designers of the model have chosen certain features to include and others to omit? How do these chosen features affect what you can learn about the real thing from the model? Refer to the background information about NASA engineers' use of scale models.

3. Discuss how scale models are not just toys but are also used for research, planning, and design. NASA uses scale models to develop new spacecraft. Introduce the X-33. You may wish to use a preconstructed model and/or images that you can find on the web sites listed under Teacher Resources (see page 5).

VOCABULARY

Canted – slanting.

Proportional – two objects that have the same ratio between all of their corresponding dimensions.

Proportionality – the process of having the same or a constant ratio.

Ratio – the relationship between two quantities, expressed as a quotient, often written as $a:b$ or a/b .

Scale – the ratio between the dimensions of an object and the corresponding dimensions of a drawing or model of the object, often written as $1:x$, where x is the scale factor.

Scale factor – how big something is in relation to something else; the constant that can be multiplied by the dimensions of a scale drawing or model to get the dimensions of the actual object; the "x" part of the scale ($1:x$).

Surface area – the area enclosed in a 2-dimensional surface; for example, the area of a rectangle.

Volume – the amount of 3-dimensional space occupied by an object; for example, the volume of a cube.

MATERIALS NEEDED

Student/team copies of

- cue cards, 1 per student
- patterns for X-33 model
(1 sheet per student; photocopy onto heavy paper)
- folding and assembly instructions
- Worksheet: Find the Scale Factor (page 18)
- Three-View Drawing of the X-33 with its full-scale measurements (page 21)
- **IMPORTANT:** at least one completed X-33 model for students to use as a reference
- paper and pencils
- sharp scissors
- metric rulers
- glue
- calculators
- graph paper (for drawing the payload box and, optionally, for measuring surface area)

Optional Materials

- rice, centimeter cubes, or similar material (for measuring volume)
- graduated cylinder (for measuring volume in standard units)

THE ACTIVITY - DAY1

1. Introduce the X-33 and VentureStar™.

Share with students the background information about the X-33 and VentureStar™ and how NASA and Lockheed Martin engineers use models to test the many new technologies that will be employed in this reusable launch vehicle. Emphasize that the X-33 itself is a kind of model.

2. Divide the class into teams of 3 to 4 students.

3. Construct the model of the X-33.

Cutting, folding, and assembling the model will take one 45-minute class period. This period does not include the time you spend on introductory activities or discussion (15 minutes). Have one completed model of the X-33 available for students to consult so they can visualize what the assembled model looks like.

- Distribute copies of pages 15-17, 19, 21 & 22, pencils, scissors, metric rulers, and glue.
- Introduce the parts of the vehicle: body, canted fins, vertical fins, body flaps, and engine.

NOTE: Using the ruler technique for folding may produce neater results than simply trying to fold on the lines.

- Remind students not to glue the back door shut.
- After each student has completed his/her own model, have the team select a model to measure.

4. Distribute the Worksheet: Find the Scale Factor (page 18) to each student.

- Record the linear dimensions of the full size X-33 that are provided on the Three-View Drawing of the X-33 (page 19). Be sure students use the dimensions marked length, width, and height for this first stage of the activity.
- Ask students how the length, width, and height of the model could be measured accurately. Students might suggest using a ruler, string, or graph paper.
- Have students measure the linear dimensions of the model to the nearest tenth of a cm and record the results on the worksheet.

5. Find the linear scale factor of the model.

- Use the measurements recorded in the worksheet table (page 18) to find the X-33:model ratio for each linear dimension and record in column D.
- Find the scale factor by simplifying the ratio in column D. Divide the numerator by the denominator. Round off the result to the nearest whole number and record it in column E; this is the scale factor. (See Teacher's Answer Key to Student Worksheet, page 20.)

NOTE: The scale factor forms one part of the scale, which is written as 1 : scale factor, e.g., 1 : 50, which is read as a scale of 1 to 50. Other ways to write the scale are 1/50 and 1 to 50.

- Find the average of the unit scale factors for all linear dimensions to determine a single scale factor for the model.
- If time allows, have students find scale factors for other linear dimensions, such as the distance between the two vertical fins.
- Discuss how the scale factor can be used and ask students to apply it to some simple problems.

For example, how big would a 46-cm square window be on your scale model? If students have decorated the side of the model with writing ("NASA" for example), ask them how tall the letters would be on the actual X-33.

6. Using the students' completed tables, verify whether the model is a true scale model.

NOTE: A true scale model is proportional. All its linear dimensions have the same scale factor. This proportionality is what makes a scale model preserve the shape of the full-size object without distortion.

- Discuss the concept of proportionality. For example, some toy figures may have heads that are too large for their bodies. If the head has a larger scale factor than the body; the toy is not a true scale model.

7. Optional: Use scaling factors to determine payload dimensions.

Encourage students, working in groups, to determine their own process for each activity. The numbered steps below are only a suggestion of possible steps.

The Venture Star has a payload bay size of approximately 458 cm x 1524 cm.

- Determine the dimensions of the payload bay of the scale model.
- Use the ratio of the Venture Star™: X-33 to find payload dimensions for the X-33. (229 cm x 762 cm)

Payload bay dimensions	Venture Star™	X-33
Length	1524 cm	$1524/2 = 762$ cm
Width	457 cm	$457/2 = 228.5 = 229$ cm

- Use the results of the X-33 payload dimensions and the scaling factor found in the classroom activity to find the payload dimensions for the scale model. (5 cm x 2 cm)

Payload bay dimensions	Venture Star™	X -33	Model
Length	1524 cm	762 cm	$762/140 = 5.4 = 5$ cm
Width	457 cm	229 cm	$229/140 = 1.6 = 2$ cm

- Determine the volume of the payload bay in the Venture Star™.
 1. Measure the body height of the scale model. (3.2 cm)
 2. Use the scaling factor to determine the height in the X-33. (448cm)
 3. Use the height determined for the X-33 and the scaling factor for the Venture Star™ to find the height of the Venture Star™. (896 cm)

	Scale model	X-33	Venture Star™
Height	3.2 cm	$3.2 \times 140 = 448$ cm	$448 \times 2 = 896$ cm

4. Calculate the volume of the payload space for the Venture Star.
 $1524 \text{ cm} \times 457 \text{ cm} \times 896 \text{ cm} = 624,035,328$ cubic centimeters
 (624.035328 cubic meters)

- What can you recognize in your classroom or school that could occupy that much space?

Analyzing the Data

Review the results of the activity by answering these questions in the journals or in a class discussion.

- What can you learn from building a model that would be difficult to learn otherwise?
- How can a model be misleading?
- What things could be different about a model that might not affect its usefulness as an engineering model? (Students should understand that different models could be used to study specific aspects of a design, allowing other aspects to vary.)

EXTENSION ACTIVITIES - DAY 2

1. Measure the surface area and find the scale factor.

NOTE: Surface area is particularly important in spacecraft design because the surface must be protected from the extreme cold of space and the heat of reentering the atmosphere.

Have students estimate the surface area scale factor of the X-33 model before they do any surface area measurements.

Divide the students into teams of 3 or 4 members. Have the teams find the surface area for just the canted fins or just the vertical fins. The surface area values given on the Three-View Drawing (page 19) are for one side of the fins.

- Ask students to brainstorm how the surface area could be measured.

Possible methods include

- dividing the surface into geometric shapes for which students know the surface area formulas, or covering the surface with graph paper and counting the squares.
- Complete the surface area row of the Find the Scale Factor worksheet (page 18). Be sure to convert all measurements to the same units.
- Compare the surface area of the model to the surface area of the full-scale X-33 to find the scale factor for surface area.
- Compare the surface area scale factor to the linear dimension scale factor and discuss why they are different and how they relate. The surface area scale factor should be the square of the linear dimension scale factor.

NOTE: Students may have difficulty recognizing that the surface area scale factor is the square of the linear dimension scale factor. One way to lead them to this discovery is to compare measurements of squares with sides measuring $1x$, $2x$, and $3x$.

- Draw three squares in the ratios $1x$, $2x$, and $3x$. Calculate the surface area for each square.
- Create a table of linear dimensions and surface area for each square. Try to find the pattern.

(Optional/Homework/Extra Credit) If a typical Thermal Protection System tile measures one foot square, calculate the number of tiles needed to cover the surface of the X-33.

2. Measure the volume and find the scale factor.

NOTE: Volume is a particularly important issue for engineers designing the X-33 Reusable Launch Vehicle. All fuel will be carried inside the body of the vehicle, instead of in external tanks, as with the Space Shuttle. It is a tremendous challenge to design fuel tanks that fit the shape of the X-33 and make the most efficient use of space.

Ask the students to estimate the volume scale factor before they make any volume measurements. (If students assumed that the volume scale factor would be the same as the linear dimension scale factor, their estimates of the X-33's volume would be wildly wrong! The volume scale factor is the cube of the linear scale factor.)

- Ask students to brainstorm how the volume of the model could be measured.

Possible methods might include

- filling the model with rice or a similar material and then pouring the material into a graduated cylinder to obtain the volume in standard units (ml), or filling the model with unit cubes (cubic centimeter or quarter-inch cubes work well) and then counting them.
- Complete the volume row of the Find the Scale Factor Worksheet (page 18).
- Compare the volume scale factor to the linear dimension scale factor and discuss why they are different.

NOTE: Students may have difficulty recognizing that the volume scale factor is the cube of the linear scale factor. One way to lead them to this discovery is by comparing cubes whose linear dimensions are 1x, 2x, and 3x.

- Build card stock boxes using the one-inch cube pattern provided. Have each student construct a cube and find its volume (one cubic inch).
- Group the boxes together to create a cube with two-inch sides. Calculate the volume for the two-inch cube (eight cubic inches).
- Group the boxes together to create a cube with three-inch sides. Calculate the volume for the three-inch cube (27 cubic inches).
- Create a table of the linear dimensions and volume for each cube. Try to find the pattern.

3. Make a model of a different scale.

Assign teams of students a particular scale. Divide the task of scaling each component accurately. Assemble the scale model.

NOTE: For younger students, the scale could be chosen to match that of a toy brought from home. Toy cars are typically 1:50 scale. When scaling up, students will find that a small error in the original measurement can become a large error when multiplied by the scale factor.

4. Assign each team to construct a scale model to meet a specific criterion.

- Determine the length and width of a scale model of the Venture Star™, given that the payload space had maximum dimensions of 1016 cm x 305 cm.
- Determine the scaling factors of the dimensions of the Venture Star™ to determine the size (1.5) of the Venture Star™ scale model constructed in this activity.

Payload bay dimensions	Venture Star	Scale model	Scaling factor
Length	1524 cm	1016 cm	$1524/1016=1.5$
Width	458 cm	305 cm	$458/305=1.5$

Scaling factor 1.5__

- Use the average of the scaling factors and the dimensions of the Venture Star™ to determine the dimensions of the scale model with a payload space of 1016 cm x 305 cm (2581 cm x 2601 cm).

Dimensions	Venture Star™	Scale model
Length	3871 cm	$3871 / 1.5 = 2581$ cm
Width	3901 cm	$3901 / 1.5 = 2601$ cm

CUE CARDS

Melanie Janetka, University of Alabama in Huntsville

Name and explain two energy sources. _____

How might test engineers use computation? _____

Robert Garcia, NASA Marshall Space Flight Center

What is a thermal protection system (TPS)? _____

Name two examples of thermal protection. _____

**Dawn Ray and Robert Garcia, NASA Marshall Space Flight Center,
Jennifer Pulley, NASA Langley Research Center**

How can we improve the performance of a bicycle? _____

Explain two forces that affect both the X-33's and a bike's performance and tell how they relate to each other.

Carl Meade, Lockheed Martin Skunkworks

How do engineers use models to test their ideas? _____

What can you learn from a scale model? _____

Eighth Grade Students at Talladega County Central

Can you take a design that works at one scale and use it for an effective design at another scale? _____

Do you have to change the design when you change the scale? _____

FOLDING AND ASSEMBLY INSTRUCTIONS

1. Carefully cut out the X-33 body. Use sharp scissors. Be sure to cut out the triangle near Tab C. Don't cut out the fins, flaps, and engine until you need them.
2. Crease along all the dashed lines. To make sharp folds, place a ruler along the line and hold it down tightly. Then slide your finger under the paper and lift it up against the ruler.
3. Cut the four slots, two for the canted fins and two for the vertical fins. Be careful to cut only on the cut lines and not on the fold lines.
4. (*Diagram 1*) Glue the back side of Tab A to the edge where it says "Glue A here." Be sure to fold the model so that all the writing is on the inside. Line up the alignment dots.

Fold up the nose and tuck the flaps into the front of the X-33. Push the nose in until it stays.

Diagram 1

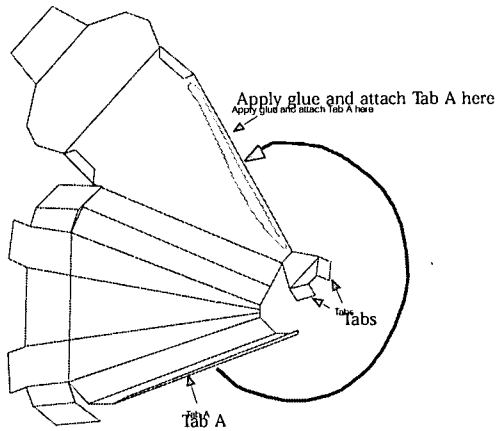

5. (Diagram 2) Glue Tab B to the flap that reads "Glue on B." Do the same with Tab C.

Diagram 2

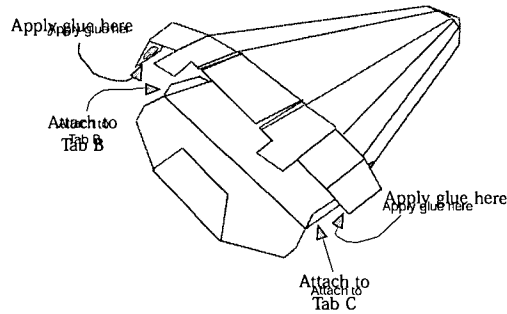

6. (Diagram 3) Cut out the canted fins. Fold each fin in half along the middle line. Be sure the markings are on the inside. Fold back the tabs of each fin. Apply glue and insert the fins in the slots that you cut on the side of the X-33.

Diagram 3

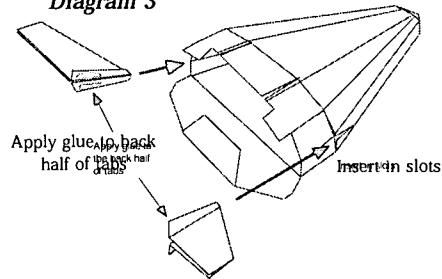

7. (Diagram 4) Cut out the vertical fins. Fold them in half on the middle line. Be sure the markings are on the inside. Fold back the tabs. Apply glue to the top side of the tabs and insert them in the slots on the top of the X-33.

Diagram 4

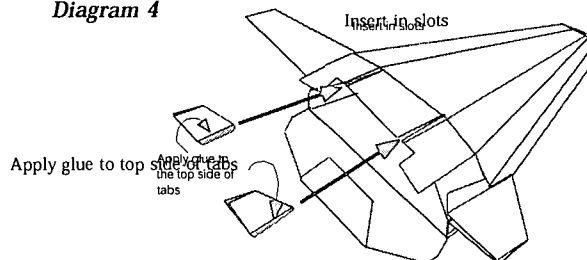

8. (Diagram 5) Close the back of the model but don't glue it. You may need to open it later.

Cut out the body flaps. Fold the body flaps in half and glue them closed. Attach the flaps under the back of the X-33.

9. (Diagram 6) Cut out the engine. Line up "Edge A" at the

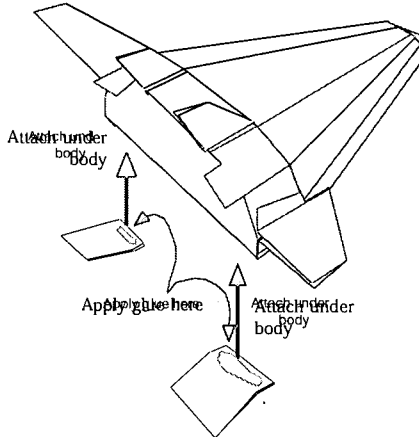

line that says "Line up edge A here" and glue it in place. Squeeze the engine so that the top and bottom are curved. Glue the engine to the back of the X-33.

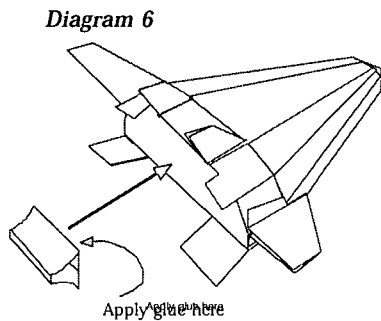

10. (Diagram 7) The finished X-33 model.

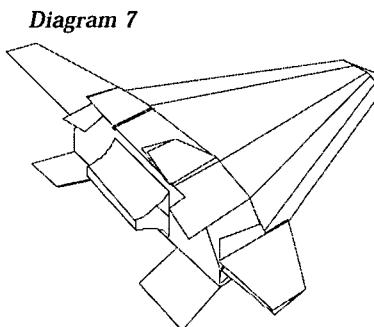

WORKSHEET: FIND THE SCALE FACTOR

1. Find the measurements of the full-size X-33 on the drawings. Record them in column B.
2. Measure the corresponding dimension on your scale model to the nearest tenth cm and record in column C.
3. Write the ratio of the measurements in column D. Make sure that the units are the same.
4. Calculate the scale factor, round to the nearest whole number and record it in column E.
5. Calculate the average scale factor and record it in the space provided below column E.

A	B		C		D	E
X-33 Dimension	Full Size X-33		Model X-33		Full-Size X-33	Scale Factor
	Measurement	Units	Measurement	Units	Model X-33	
Length (nose to tip of body flap)					_____	
Width (tip of canted fin to tip of other canted fin)					_____	
Body Height					_____	
Average Scale Factor _____						
Surface Area					_____	
Volume					_____	

THREE-VIEW DRAWING OF X-33 WITH FULL-SIZE DIMENSIONS

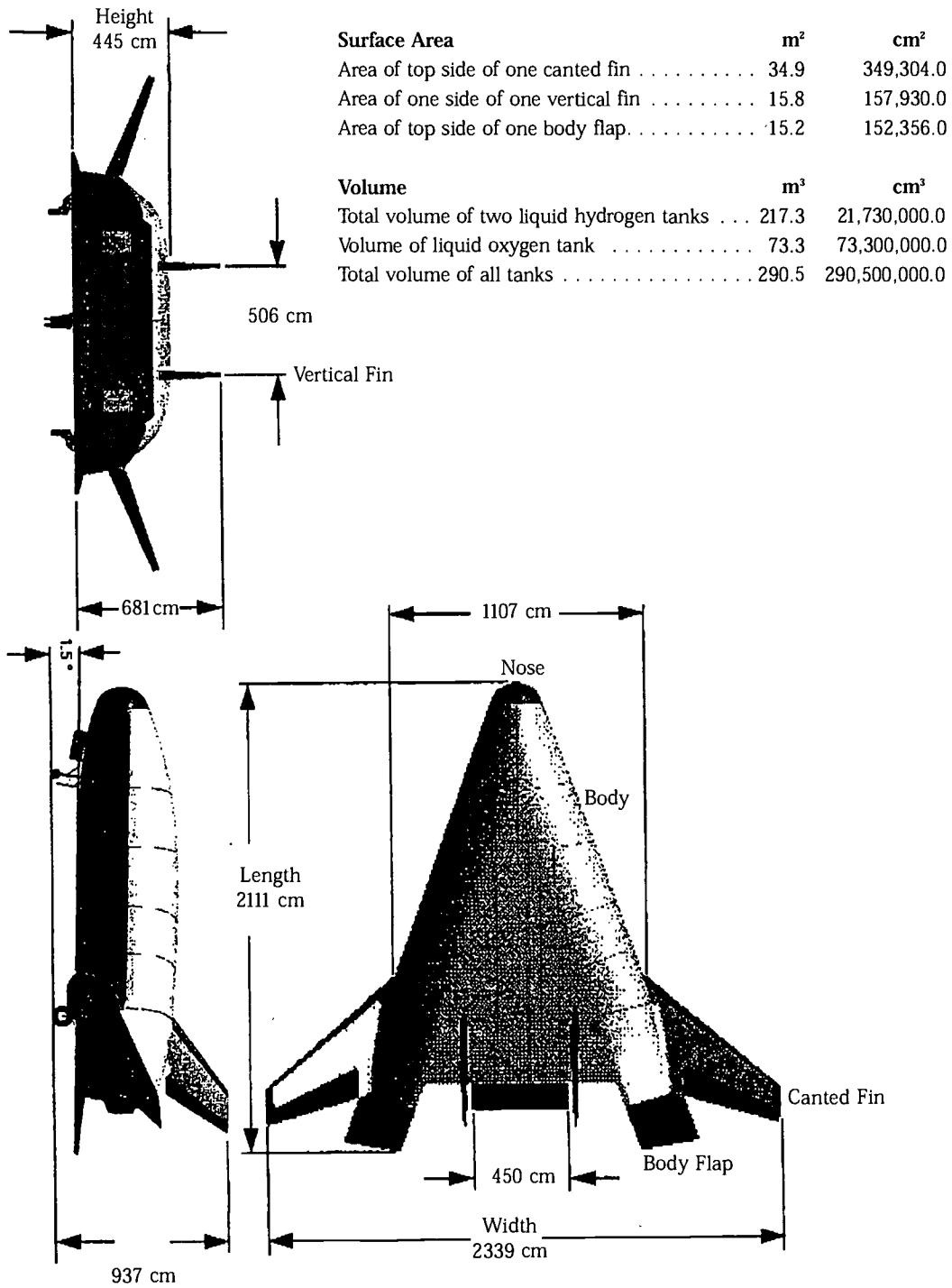

TEACHER'S ANSWER KEY TO STUDENT WORKSHEET

1. Find the measurements of the full-size X-33 on the three-view drawing (page 19). Record them in column B.
2. Measure the corresponding dimension on your scale model to the nearest tenth cm and record in column C.
3. Write the ratio of the measurements in column D. Make sure that the units are the same.
4. Calculate the scale factor, round to the nearest whole number, and record it in column E.

A	B		C		D	E
X-33 Dimension	Full Size X-33		Model X-33		Full-Size X-33	Scale Factor
	Measurement	Units	Measurement	Units	Model X-33	
Length (nose to tip of body flap)	2111	cm	15.2	cm	$\frac{2111 \text{ cm}}{14.6 \text{ cm}}$	139
Width (tip of canted fin to tip of other canted fin)	2339	cm	16.5	cm	$\frac{2339 \text{ cm}}{16.5 \text{ cm}}$	142
Body Height	445	cm	3.2	cm	$\frac{445 \text{ cm}}{3.2 \text{ cm}}$	139
Average Scale Factor						140

NOTE: Measurements recorded for the X-33 model were determined by measuring the paper model in one lab and are meant to be a guide. Measurements may vary in the classroom construction but should be close to those recorded.

MODEL X-33 PATTERN SHEET

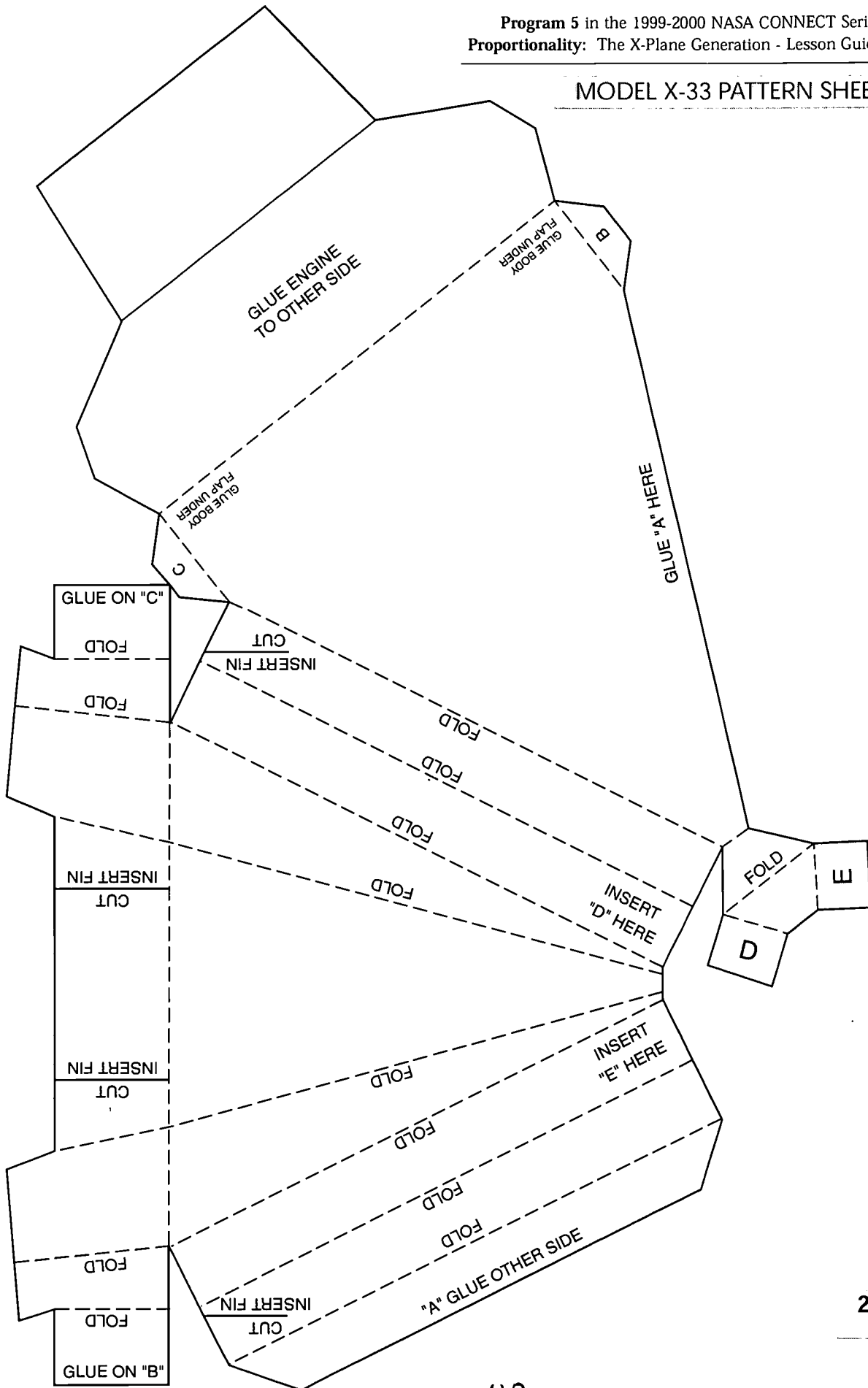

MODEL X-33 FINS, FLAPS, AND ENGINE

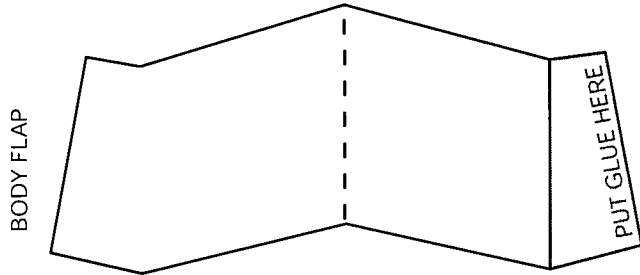
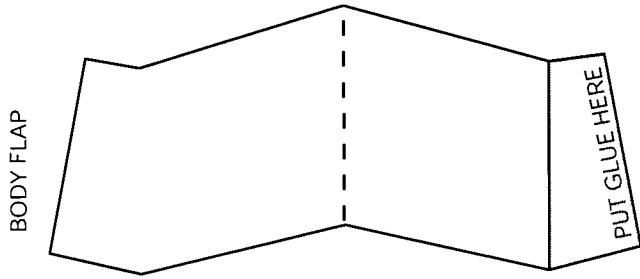

ENGINE

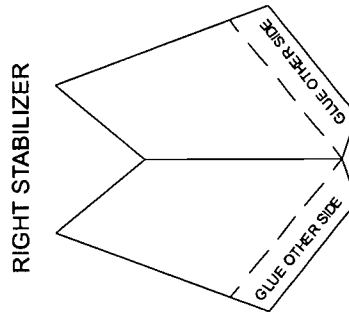
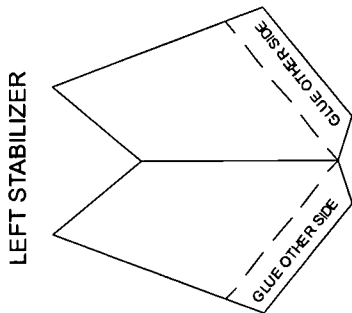
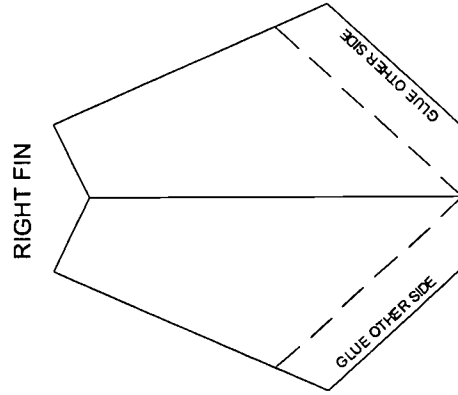
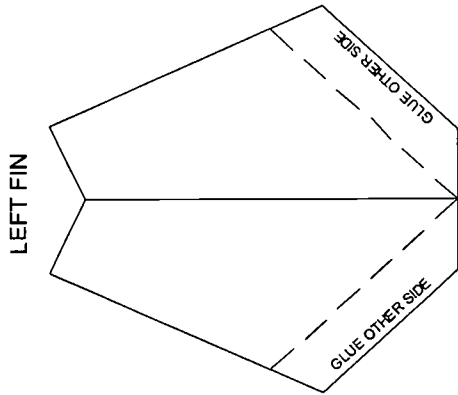
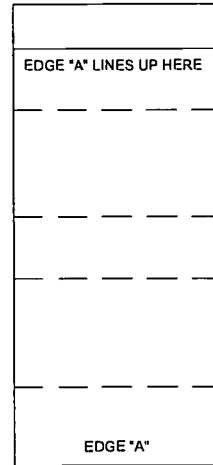



*U.S. Department of Education
Office of Educational Research and Improvement (OERI)
National Library of Education (NLE)
Educational Resources Information Center (ERIC)*



NOTICE

Reproduction Basis



This document is covered by a signed "Reproduction Release (Blanket)" form (on file within the ERIC system), encompassing all or classes of documents from its source organization and, therefore, does not require a "Specific Document" Release form.



This document is Federally-funded, or carries its own permission to reproduce, or is otherwise in the public domain and, therefore, may be reproduced by ERIC without a signed Reproduction Release form (either "Specific Document" or "Blanket").