

DOCUMENT RESUME

ED 442 481

JC 000 403

TITLE Student Characteristics and Enrollment Trends, 1995-1999. Research Report.

INSTITUTION Cuesta Coll., San Luis Obispo, CA. Matriculation and Research Services.

REPORT NO CC-MRS-RR-99/00-02

PUB DATE 1999-10-00

NOTE 36p.; Cover title varies.

AVAILABLE FROM For full text: <http://academic.cuesta.cc.ca.us/research>.

PUB TYPE Numerical/Quantitative Data (110)

EDRS PRICE MF01/PC02 Plus Postage.

DESCRIPTORS Annual Reports; Community Colleges; *Enrollment; *Enrollment Trends; Institutional Research; Place of Residence; Regional Characteristics; School Community Relationship; *School Demography; *Student Characteristics; Tables (Data); *Two Year College Students; Two Year Colleges

ABSTRACT

This report contains 22 tables and 25 figures showing student characteristics and enrollment trends from 1995 to 1999 for Cuesta College. Section 1 presents five-year student characteristics and enrollment trends; Section 2 outlines enrollment by Cuesta College educational region, 1998-99. Both sections contain data on enrollment status, course load, units and degrees completed, gender, ethnicity, age, disabilities, geographic region, educational objectives, and students from local high schools. Highlights include: (1) enrollment at Cuesta College is at an all-time high of 9,229 students and continues to increase; (2) the proportion of students carrying fewer than six units has decreased (31.3%), and the proportion of students carrying more than 15 units has increased (6.4%); (3) there is a continual increase in the number of students with disabilities; (4) the San Luis campus is divided almost equally between male and female students, while the North County campus boasts a female enrollment of 67.7% of the student body; and (5) the percentage of historically underrepresented ethnic minority students increased at each campus in 1999. Appendices include: (1) Enrollment history, 1965-99; (2) Local residency of students at all sites, 1998-99; (3) Local residency of students at San Luis Obispo campus, 1999; (4) Local residency of students at North County campus, 1999; (5) Local residency of students at South County campus 1999; and (6) Regional enrollment comparisons, 1999. (RDG)

Student Characteristics and Enrollment Trends Fall 1999

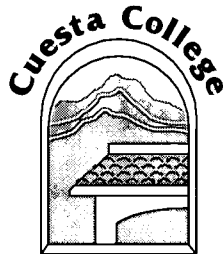

U.S. DEPARTMENT OF EDUCATION
Office of Educational Research and Improvement
EDUCATIONAL RESOURCES INFORMATION
CENTER (ERIC)

- This document has been reproduced as received from the person or organization originating it.
- Minor changes have been made to improve reproduction quality.

- Points of view or opinions stated in this document do not necessarily represent official OERI position or policy.

October 1999

PERMISSION TO REPRODUCE AND
DISSEMINATE THIS MATERIAL HAS
BEEN GRANTED BY

F. Martinez

TO THE EDUCATIONAL RESOURCES
INFORMATION CENTER (ERIC)

1

Research Report No. 99/00-02

Matriculation and Research Services

7000403



EXECUTIVE BRIEF

FIVE -YEAR STUDENT CHARACTERISTICS AND ENROLLMENT TRENDS (1995-1999)

Table 1 (and Appendix I) shows that enrollment at Cuesta College continues to increase—although more gradually than in previous years—and is now at an all-time high of 9,229 students. Continuing students continue to be in the majority constituting just above 51 percent of the student body, indicating that nearly half of the enrollment is new to Cuesta this semester.

Table 2 indicates relative stability in the proportion of students taking only day classes (41.8% in 1999). However, the proportion of students enrolled in both day and evening classes has increased from 35.1% in 1998 to 36.3% in 1999. Accordingly, the proportion of students enrolled only in evening classes has fallen by 1.2 percentage points to 22.0% in 1999.

Table 3 indicates stability of student course load within the 6.1 to 15 units categories. The proportion of students carrying fewer than 6 units has decreased (31.3%) as the proportion of students carrying more than 15 units has increased (6.4%).

Table 4 shows student enrollment by number of units/degrees completed. While stability is also apparent, it can be seen that the percentage of students who have earned fewer than 30 units has been slowly decreasing during the last five years—from 70.5 percent in 1995, down to 66.6 percent in 1998. Simultaneously, the percentages of students having completed either an AA/AS or BA/BS degree(s) have increased from 6.2 percent in 1995 to 7.3 percent in 1999 and from 2.7 percent in 1995 to 4.7 percent in 1999 respectively.

Table 5 shows the gender distribution of the Cuesta student body. As in prior years, female students constitute 54.7 percent of the enrollment and males constitute only 45.3 percent, representing a 1.4 percentage point gain from a year ago in the proportion of females.

Table 6 shows the ethnic configuration of Cuesta's students. The percentage of white students has decreased from 1998 to 75.2 percent in 1999. This decrease is redistributed as an increase in the proportion of Hispanic students (13.4%). The remainder of the ethnic categories remained essentially unchanged from 1998.

Table 7 shows the age distribution of Cuesta students. Again, the relative percentages have remained stable over time in all but two categories. The proportion of 19-year-old students has decreased by 1.2 percentage points as the 41-50 category has increased by a like amount. The median age of the overall student body is 22 while the mean age is 26.

Table 8 shows a continual increase in the number of students with disabilities. Note particularly that the "learning disabled" category reflects the increasing number of high school graduates with a learning disability. Also note that the "other" category reflects increased identification of students with an "attention-deficit disorder."

Table 9 indicates that 58.5 percent of Cuesta's first-time students have been residents of San Luis Obispo County for at least one year. The remaining 41.5 percent relocated to San Luis Obispo County from out of the area to attend Cuesta. The proportion of "local" students increased by 4.4 percentage points in 1999.

Table 10 shows first-time students from local high schools attending Cuesta. The proportions of first-time students coming from Atascadero and San Luis Obispo have fallen by a combined 4.7 percentage points, while the proportions from Paso Robles, Templeton and Arroyo Grande have risen by a combined 6.4 percentage points from 1998 figures.

Table 11 shows the educational objective for attending Cuesta College as stated by students. The information regarding goals and objectives is obtained from the student's original application for admission to Cuesta. Naturally, these objectives can change as a student gains college experience and receives counseling. In 1999, 58.2 percent entered Cuesta with the stated objective of transferring to a four-year college—down 1.5 percentage points from a year ago.

Table 12 is the last table in this section of the report. This table shows the number and percentage of graduates from each of the local feeder high schools who are awarded Associate of Arts (A.A.) or Associate of Science degrees (A.S.) by Cuesta. The 1999 figures show that roughly 23 percent of the A.A./A.S. degrees awarded to local high school graduates were Atascadero alumni. These figures are mainly a function of high school graduation rates and subsequent attendance rates at Cuesta two to three years prior. These figures should be tempered by the knowledge that a student may choose to transfer to a four-year college without choosing to obtain either an A.A. or A. S. degree.

BEST COPY AVAILABLE

EXECUTIVE BRIEF CONTINUED
STUDENT CHARACTERISTICS AND ENROLLMENT TRENDS BY EDUCATIONAL REGION (1998-1999)

Table 13 shows the enrollment status of students for each of Cuesta's three educational regions over the last two years. The new North County campus opened with 1,293 students last fall. For 1999 enrollment at the North County campus shows an impressive 20.2 percent increase to a new high of 1,554. Conversely, the San Luis Obispo campus lost 54 students from last year. The South County center increased its enrollment by 12 students to a new high of 384 in 1999.

Table 14 shows day/evening status of students by site. The San Luis Obispo campus continues to exhibit the greatest percentage of day only students (47.8% in 1999). Both North and South County students continue to enroll in more evening courses, which is due primarily to when the majority of courses are scheduled at each site. Roughly 47 percent of North County and 93 percent of South County students are evening-only students. Reflective, however, of North County course expansion, the number of day-only students increased by approximately 12 percentage points at the North County campus.

Table 15 shows student course load by site. The pattern of course loads by region has remained fairly stable over the last two years. The San Luis Obispo campus continues to attract more full-time students (12 or more units)—nearly 50% in 1999. By comparison, the North and South County campuses attract less full-time students—29 percent and 39 percent respectively in 1999.

Table 16 shows the number of units completed by students by site. The vast majority of students have completed less than 30 units—regardless of educational site.

Table 17 shows student gender by site. While the San Luis campus is divided roughly equally between male and female students (47.4% vs. 52.6% in 1999), the North County campus boasts a female enrollment of greater than two-thirds (67.7%) of the student body. South County falls in the middle with roughly 60 percent female enrollment in 1999.

Table 18 shows the ethnic configuration of the students at each campus. The percentage of historically underrepresented ethnic minority students increased at each campus in 1999. The increases were most prominent at the South and North County campus. South county enrollment of ethnic minorities increased by 4.5 percentage points to nearly 28 percent in 1999. Similarly, ethnic minority students now comprise just over 27 percent (compared to roughly 24 percent in 1998) of the total student population at the North County campus. The bulk of this increase at the North County (and elsewhere) was brought about by increases in Hispanic enrollments.

Table 19 shows the age distribution of students by site. The age distributions at each campus have remained stable over the last two years. The median ages of students in 1999 by educational region are as follows: San Luis Obispo – 21; North County – 25; South County – 22. As is clear from the median ages, the North County continues to attract an older student body than the other two regions.

Table 20 is a new table for 1999, which explores the number and percentage of local and out-of-area first-time students by educational region. The San Luis Obispo campus attracts the greatest percentage of out-of-area first-time students (roughly 53 percent). The North and South county, on the other hand, serve greater proportions of local students (82% and 89% respectively).

Table 21 shows high school of origin for first-time students by educational region. Each local high school continues to contribute students to a campus in direct proportion to its proximity to that campus.

Table 22 shows student educational objective by campus. Again in 1999, the North County campus has a substantially higher proportion of its students (20.1%) seeking vocational goals than the other campuses (roughly 13%). The San Luis campus continues to lead in the percentage of students indicating transfer as their educational objective (61.7% in 1999).

APPENDICES

Appendix I shows a complete (1965 – 1999) enrollment history of Cuesta College—from 1,670 to 9,229 students.

Appendices II through V depict, overall and by educational region, the number and percent of students residing in the various parts of San Luis Obispo County. Notwithstanding the San Luis Obispo campus, the overwhelming majority of students lives in close proximity to the campuses they are attending. Specifically, just below 46 percent of students enrolled at the San Luis Obispo campus reside in San Luis Obispo, whereas 96 percent of North County students and 83 percent of South County students reside in close proximity to their respective campuses.

Appendix VI explores—in Venn diagram form—the number of students attending each individual (or a combination of) Cuesta campus.

BEST COPY AVAILABLE



TABLE OF CONTENTS

INTRODUCTION

EXECUTIVE BRIEF *i*
TABLE OF CONTENTS *iii*
LIST OF FIGURES *iv*

(I) FIVE YEAR STUDENT CHARACTERISTICS AND ENROLLMENT TRENDS 1995-1999

STUDENT ENROLLMENT STATUS *1*
STUDENT ENROLLMENT BY DAY/EVENING STATUS *2*
STUDENT COURSE LOAD *3*
STUDENT LEVEL-UNITS OR DEGREES COMPLETED *4*
STUDENT GENDER *5*
STUDENT ETHNICITY *6*
STUDENT AGE *7*
STUDENTS WITH DISABILITIES *8*
LOCAL AND OUT-OF-AREA FIRST-TIME STUDENTS *9*
FIRST-TIME STUDENTS FROM LOCAL HIGH SCHOOLS *10*
STUDENT EDUCATIONAL OBJECTIVES *11*
AAAS DEGREE AWARDED TO LOCAL HIGH SCHOOL GRADUATES *12*

(II) ENROLLMENT BY CUESTA COLLEGE EDUCATIONAL REGION 1998-1999

STUDENT ENROLLMENT STATUS BY REGION *13*
STUDENT ENROLLMENT BY DAY/EVENING STATUS BY REGION *13*
STUDENT COURSE LOAD BY REGION *13*
STUDENT LEVEL - UNITS OR DEGREE(S) COMPLETED BY REGION *13*
STUDENT GENDER BY REGION *14*
STUDENT ETHNICITY BY REGION *14*
STUDENT AGE BY REGION *14*
LOCAL AND OUT-OF-AREA FIRST-TIME STUDENTS BY REGION (1999 ONLY) *15*
FIRST-TIME STUDENTS FROM LOCAL HIGH SCHOOLS BY REGION *15*
STUDENT EDUCATIONAL OBJECTIVE BY REGION *16*

(III) APPENDICES

APPENDIX I: ENROLLMENT HISTORY - ALL SITES (1965-1999) *17*
APPENDIX II: LOCAL RESIDENCY OF CUESTA STUDENTS - ALL SITES UNDUPLICATED (1998-1999) *18*
APPENDIX III: LOCAL RESIDENCY OF STUDENTS ENROLLED AT THE SAN LUIS OBISPO CAMPUS (1999) *19*
APPENDIX IV: LOCAL RESIDENCY OF STUDENTS ENROLLED AT THE NORTH COUNTY CAMPUS (1999) *20*
APPENDIX V: LOCAL RESIDENCY OF STUDENTS ENROLLED AT THE SOUTH COUNTY SITE (1999) *21*
APPENDIX VI: REGIONAL ENROLLMENT COMPARISONS - VENN DIAGRAM (1999) *22*
GLOSSARY OF TERMS *23*



LIST OF FIGURES

FIGURE 1: NUMBER STUDENTS BY ENROLLMENT STATUS 1

FIGURE 2: PERCENTAGE OF STUDENTS BY ENROLLMENT STATUS 1

FIGURE 3: NUMBER OF DAY/EVENING STUDENTS..... 2

FIGURE 4: PERCENTAGE OF DAY/EVENING STUDENTS 2

FIGURE 5: NUMBER OF STUDENTS BY COURSE LOAD 3

FIGURE 6: PERCENTAGE OF STUDENTS BY COURSE LOAD 3

FIGURE 7: NUMBER OF STUDENTS BY LEVEL 4

FIGURE 8: PERCENTAGE OF STUDENTS BY LEVEL 4

FIGURE 9: NUMBER OF STUDENTS BY GENDER 5

FIGURE 10: PERCENTAGE OF STUDENTS BY GENDER 5

FIGURE 11: PERCENTAGE OF STUDENTS BY ETHNICITY 6

FIGURE 12: COMPARISON OF THE NUMBER OF WHITE AND OTHER ETHNICITIES..... 6

FIGURE 13: COMPARISON OF THE PERCENTAGE OF WHITE AND OTHER ETHNICITIES 6

FIGURE 14: NUMBER OF STUDENTS BY AGE 7

FIGURE 15: PERCENTAGE OF STUDENTS BY AGE 7

FIGURE 16: NUMBER OF STUDENTS BY DISABILITY 8

FIGURE 17: PERCENTAGE OF STUDENTS BY DISABILITY 8

FIGURE 18: NUMBER OF LOCAL AND OUT-OF-AREA FIRST-TIME STUDENTS 9

FIGURE 19: PERCENTAGE OF LOCAL AND OUT-OF-AREA FIRST-TIME STUDENTS 9

FIGURE 20: NUMBER OF FIRST-TIME STUDENTS FROM LOCAL HIGH SCHOOLS 10

FIGURE 21: PERCENTAGE OF FIRST-TIME STUDENTS FROM LOCAL HIGH SCHOOLS 10

FIGURE 22: NUMBER OF STUDENTS BY EDUCATIONAL OBJECTIVE 11

FIGURE 23: PERCENTAGE OF STUDENTS BY EDUCATIONAL OBJECTIVE 11

FIGURE 24: NUMBER OF AWARDS TO LOCAL HIGH SCHOOL GRADUATES 12

FIGURE 25: PERCENTAGE OF AWARDS TO LOCAL HIGH SCHOOL GRADUATES 12

FIGURE 26: ENROLLMENT HISTORY 17

FIGURE 27: LOCAL RESIDENCY OF CUESTA STUDENTS - ALL SITES UNDUPLICATED (1998-1999) 18

FIGURE 28: LOCAL RESIDENCY OF STUDENTS ENROLLED AT THE SAN LUIS OBISPO CAMPUS (1999) 19

FIGURE 29: LOCAL RESIDENCY OF STUDENTS ENROLLED AT THE NORTH COUNTY CAMPUS (1999) 20

FIGURE 30: LOCAL RESIDENCY OF STUDENTS ENROLLED AT THE SOUTH COUNTY SITE (1999) 21

FIGURE 31: REGIONAL ENROLLMENT COMPARISONS - VENN DIAGRAM (1999) 22

FIVE-YEAR STUDENT CHARACTERISTICS AND ENROLLMENT TRENDS (1995-1999)



Student Characteristics and Enrollment Trends 1995 -1999

STUDENT ENROLLMENT STATUS

TABLE 1	1995		1996		1997		1998		1999	
	N	%	N	%	N	%	N	%	N	%
First-Time Students	1638	20.8	1632	20.1	1927	22.3	2087	22.8	2131	23.1
New Transfer Students	1123	14.2	1156	14.2	1289	14.9	1259	13.8	1304	14.1
Returning Transfer Students	127	1.6	282	3.5	249	2.9	283	3.1	247	2.7
Returning Students	590	7.5	589	7.3	767	8.9	822	9.0	806	8.7
Continuing Students	3910	49.6	4090	50.3	4387	50.7	4651	50.8	4721	51.2
Undeclared/Unknown	493	6.3	377	4.6	37	0.4	54	0.6	20	0.2
TOTAL	7881	100.0	8126	100.0	8656	100.0	9156	100.0	9229	100.0

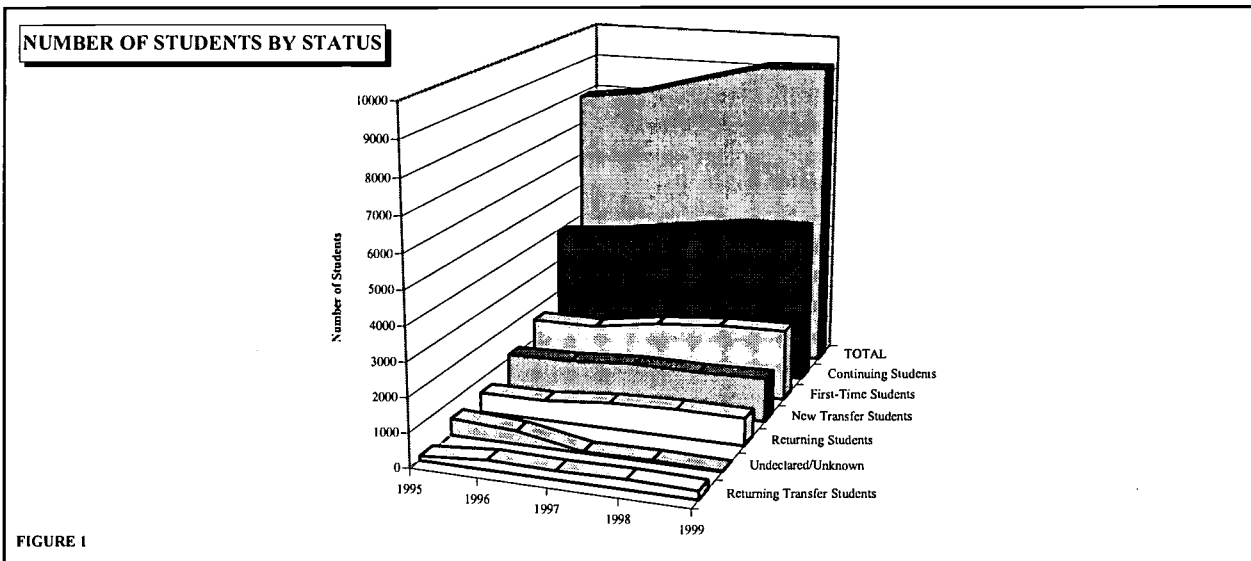

FIGURE 1

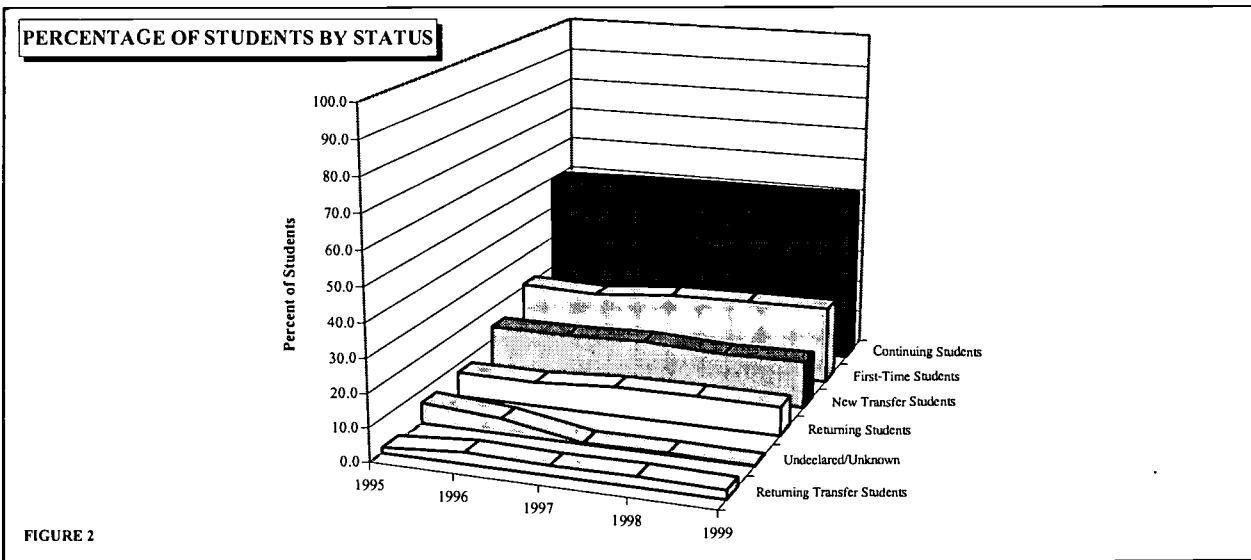

FIGURE 2

HIGHLIGHTS/OBSERVATIONS

- ⇒ Enrollment is at an all-time high.
- ⇒ The percentage of continuing students remains relatively constant.
- ⇒ The percentage of first-time students continues to slowly increase.

BEST COPY AVAILABLE



Student Characteristics and Enrollment Trends 1995 -1999

STUDENT ENROLLMENT BY DAY/EVENING STATUS

TABLE 2	1995		1996		1997		1998		1999	
	N	%	N	%	N	%	N	%	N	%
Day Students	3454	43.8	3501	43.1	3704	42.8	3816	41.7	3854	41.8
Day and Evening Students	2754	34.9	2832	34.8	2956	34.1	3216	35.1	3346	36.3
Evening Students	1672	21.2	1793	22.1	1996	23.1	2124	23.2	2029	22.0
TOTAL	7880	100.0	8126	100.0	8656	100.0	9156	100.0	9229	100.0

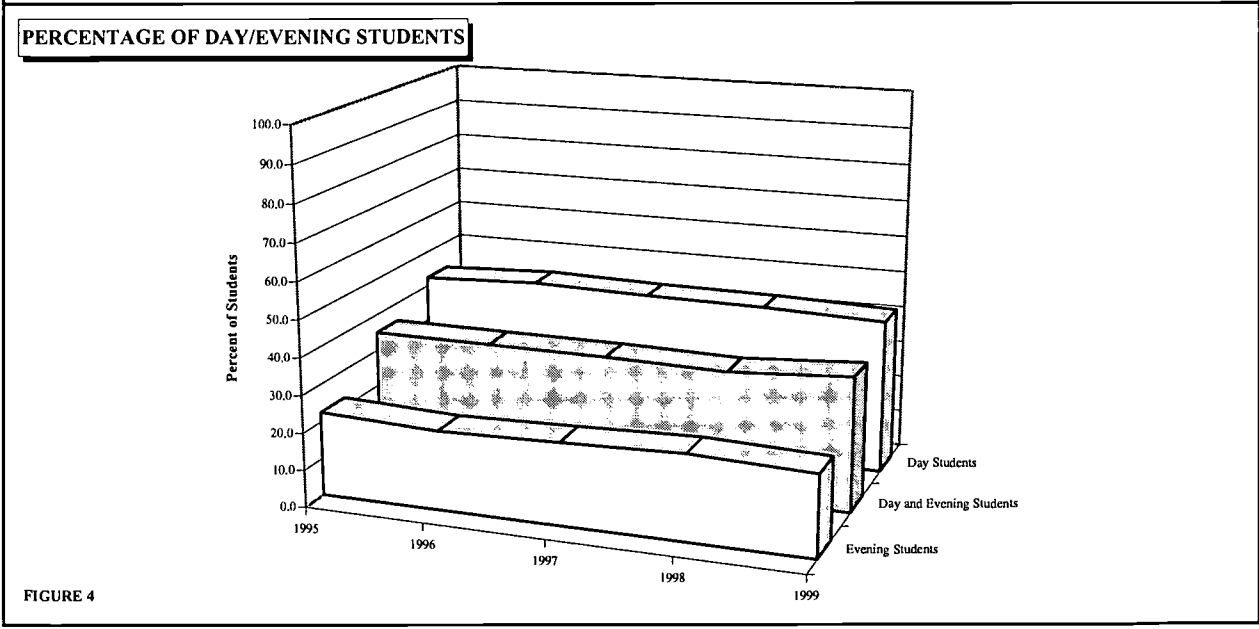
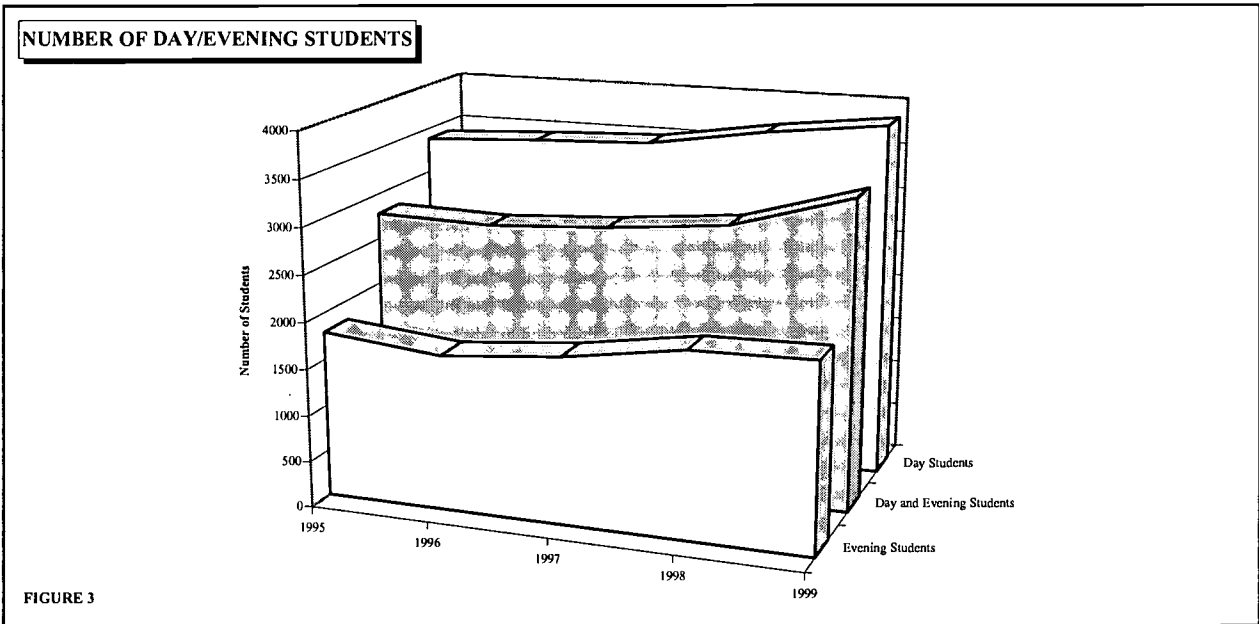

HIGHLIGHTS/OBSERVATIONS

BEST COPY AVAILABLE



Student Characteristics and Enrollment Trends 1995 -1999

STUDENT COURSE LOAD

TABLE 3	1995		1996		1997		1998		1999	
	N	%	N	%	N	%	N	%	N	%
6 or fewer units	2516	31.9	2624	32.4	2698	31.2	2946	32.2	2887	31.3
6.1-11.9 units	1977	25.1	1877	23.2	2167	25.1	2190	23.9	2143	23.2
12-15 units	2944	37.3	3125	38.6	3346	38.7	3533	38.6	3606	39.1
More than 15 units	447	5.7	472	5.8	431	5.0	487	5.3	593	6.4
TOTAL	7884	100.0	8098	100.0	8642	100.0	9156	100.0	9229	100.0

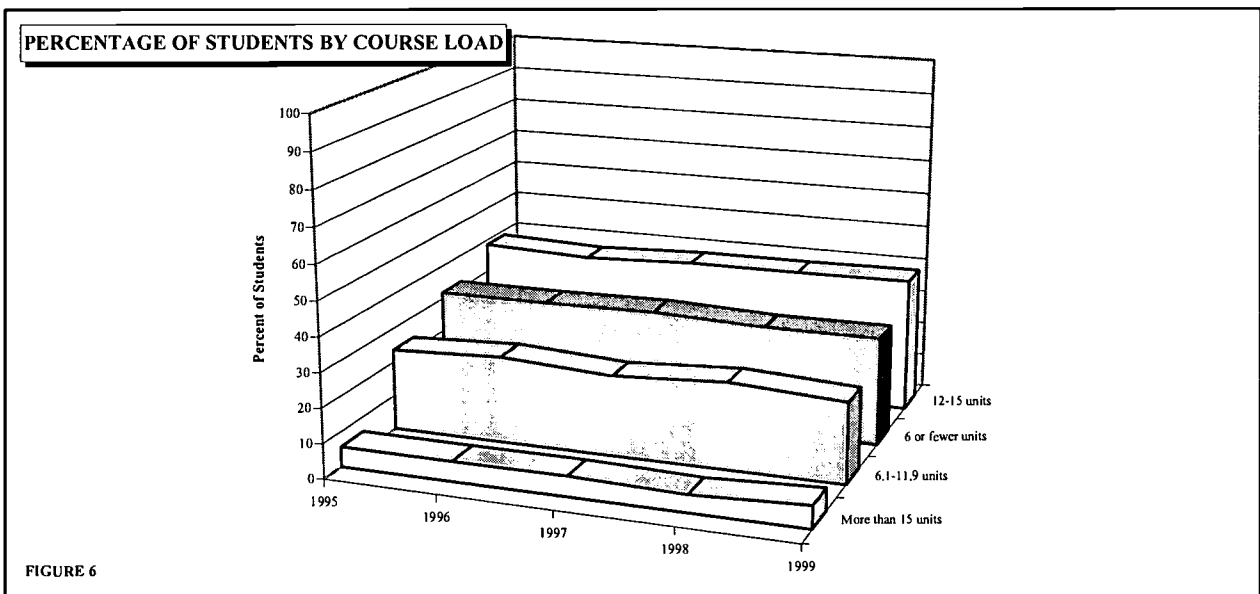
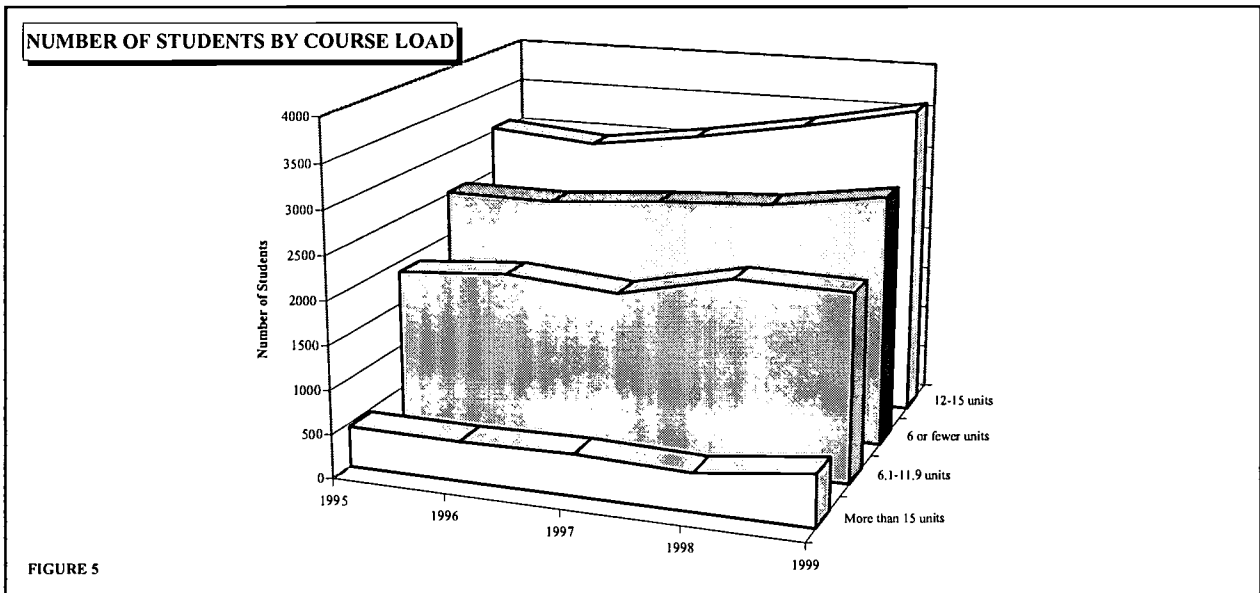

HIGHLIGHTS/OBSERVATIONS

BEST COPY AVAILABLE



Student Characteristics and Enrollment Trends 1995 -1999

STUDENT LEVEL-UNITS OR DEGREE(S) COMPLETED

TABLE 4	1995		1996		1997		1998		1999	
	N	%	N	%	N	%	N	%	N	%
Fewer than 30 Units	5562	70.5	5629	69.5	6007	69.5	6162	67.3	6148	66.6
30-59.9 Units	1288	16.3	1284	15.9	1359	15.7	1559	17.0	1543	16.7
60 or more (No Degree)	334	4.2	366	4.5	395	4.6	429	4.7	435	4.7
AA/AS Degree	488	6.2	514	6.3	558	6.5	645	7.0	673	7.3
BA/BS Degree or higher	212	2.7	305	3.8	323	3.7	361	3.9	430	4.7
TOTAL	7884	100.0	8098	100.0	8642	100.0	9156	100.0	9229	100.0

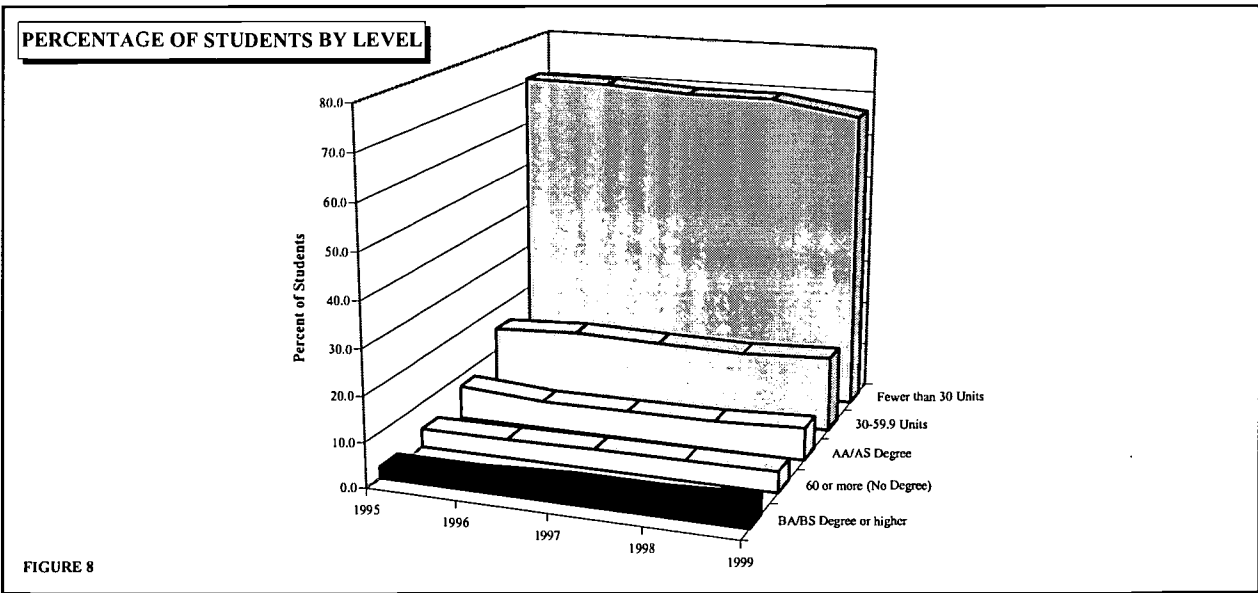
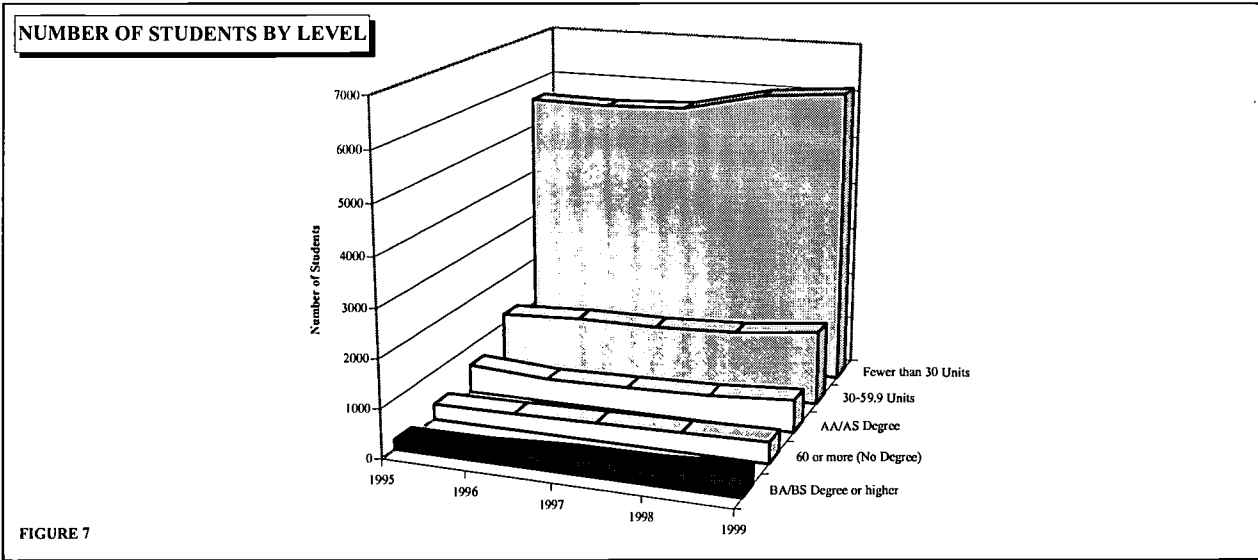

HIGHLIGHTS/OBSERVATIONS

- ➡ The percentage of students with fewer than 30 units continues to steadily decrease.
- ➡ The percentage of students already possessing degrees continues to slowly increase.

BEST COPY AVAILABLE



Student Characteristics and Enrollment Trends 1995 -1999

STUDENT GENDER

TABLE 5	1995		1996		1997		1998		1999	
	N	%	N	%	N	%	N	%	N	%
Female	4160	53.2	4396	54.3	4613	53.4	4850	53.3	5045	54.7
Male	3653	46.8	3696	45.7	4029	46.6	4249	46.7	4184	45.3
TOTAL	7813	100.0	8092	100.0	8642	100.0	9099	100.0	9229	100.0

* Unknowns were divided proportionately within the male and female categories

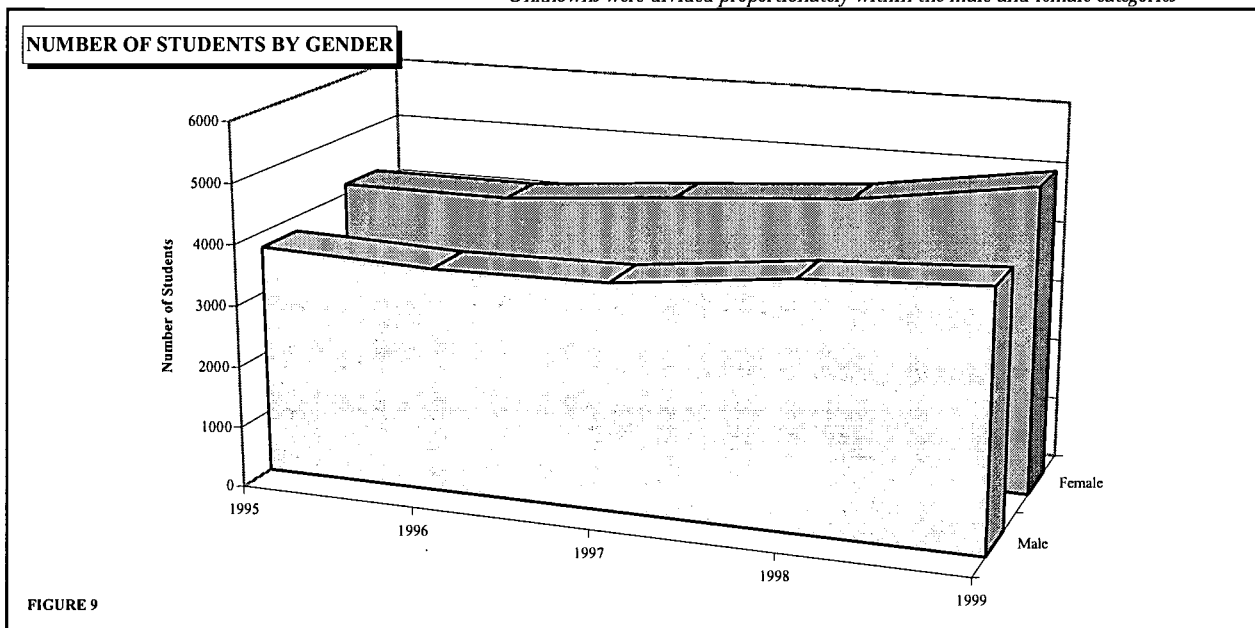

FIGURE 9

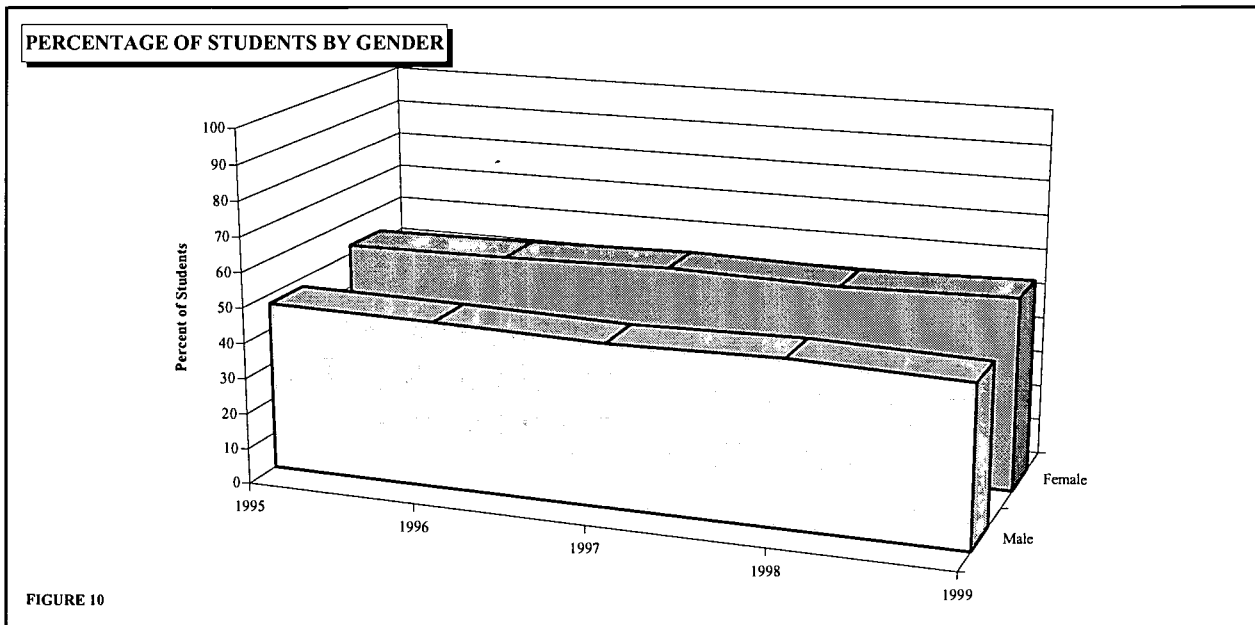

FIGURE 10

HIGHLIGHTS/OBSERVATIONS

➡ The percentage of females continues to dominate the percentage of males.



Student Characteristics and Enrollment Trends 1995 -1999

STUDENT ETHNICITY

TABLE 6	1995		1996		1997		1998		1999	
	N	%	N	%	N	%	N	%	N	%
American Indian	117	1.5	128	1.6	109	1.3	120	1.3	122	1.3
Asian	275	3.5	250	3.1	297	3.4	306	3.3	300	3.3
Black	128	1.6	146	1.8	152	1.8	169	1.8	148	1.6
Filipino	97	1.2	122	1.5	120	1.4	125	1.4	138	1.5
Hispanic	1012	12.8	1039	12.8	1079	12.5	1133	12.4	1241	13.4
White	6000	76.1	6172	76.2	6606	76.4	6967	76.1	6942	75.2
Other/Undeclared	255	3.2	241	3.0	279	3.2	336	3.7	338	3.7
TOTAL	7884	100.0	8098	100.0	8642	100.0	9156	100.0	9229	100.0

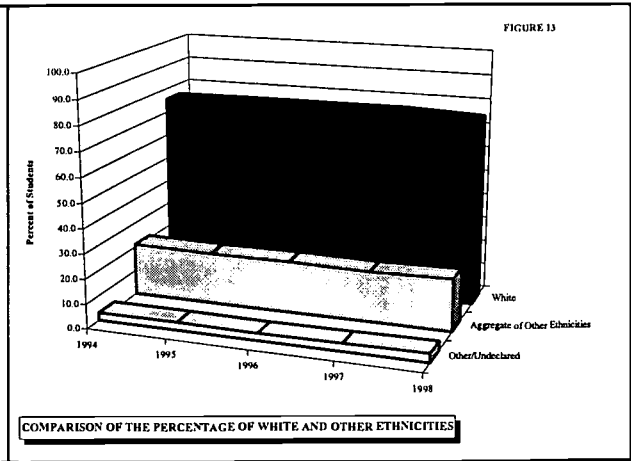
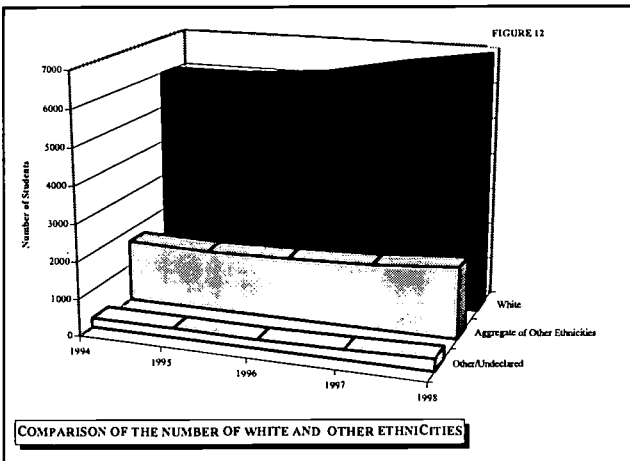
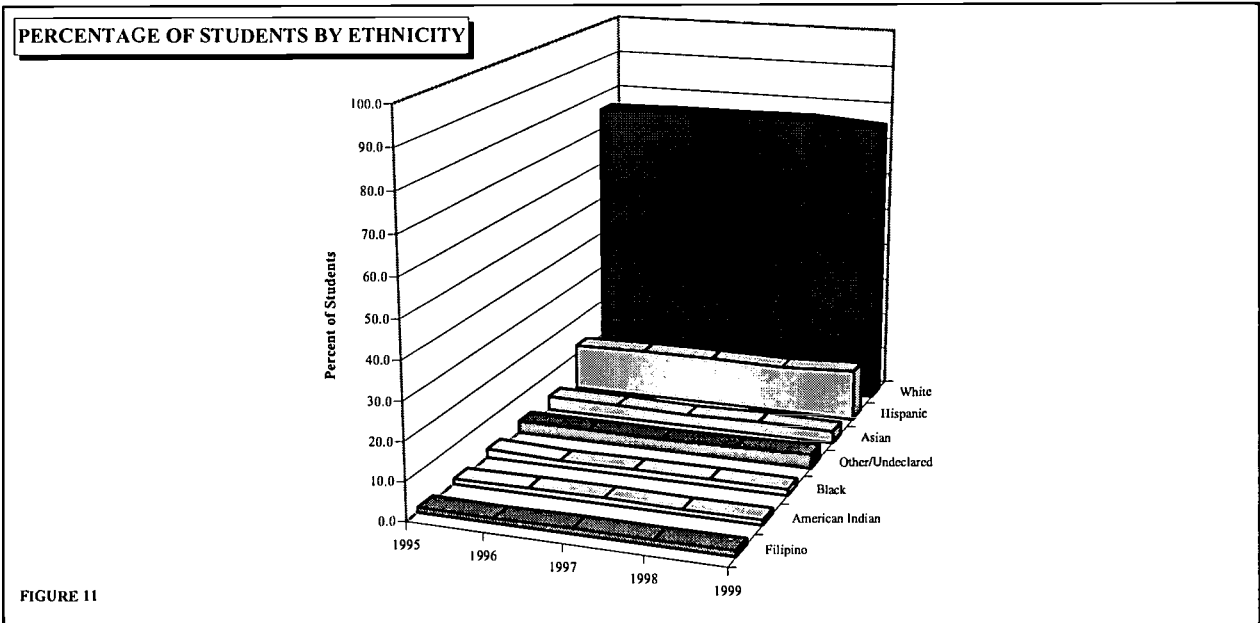

HIGHLIGHTS/OBSERVATIONS

➔ The percentage of Hispanic students continues to increase slowly as the percentage of white students decreases.

BEST COPY AVAILABLE



Student Characteristics and Enrollment Trends 1995 -1999

STUDENT AGE

TABLE 7	1995		1996		1997		1998		1999	
	N	%	N	%	N	%	N	%	N	%
17 and under	311	3.9	351	4.3	392	4.5	436	4.8	435	4.7
18 only	1050	13.3	1064	13.1	1213	14.0	1246	13.6	1265	13.7
19 only	1096	13.9	1159	14.3	1217	14.1	1365	14.9	1263	13.7
20-21	1579	20.0	1654	20.4	1790	20.7	1903	20.8	1913	20.7
22-25	1283	16.3	1279	15.8	1336	15.5	1408	15.4	1453	15.7
26-30	713	9.0	785	9.7	777	9.0	778	8.5	763	8.3
31-40	985	12.5	995	12.3	984	11.4	1007	11.0	1009	10.9
41-50	575	7.3	588	7.3	659	7.6	682	7.4	782	8.5
51-65	158	2.0	168	2.1	190	2.2	267	2.9	274	3.0
Over 65	45	0.6	32	0.4	64	0.7	59	0.6	71	0.8
Unknown	89	1.1	23	0.3	20	0.2	5	0.1	1	0.0
TOTAL	7884	100.0	8098	100.0	8642	100.0	9156	100.0	9229	100.0

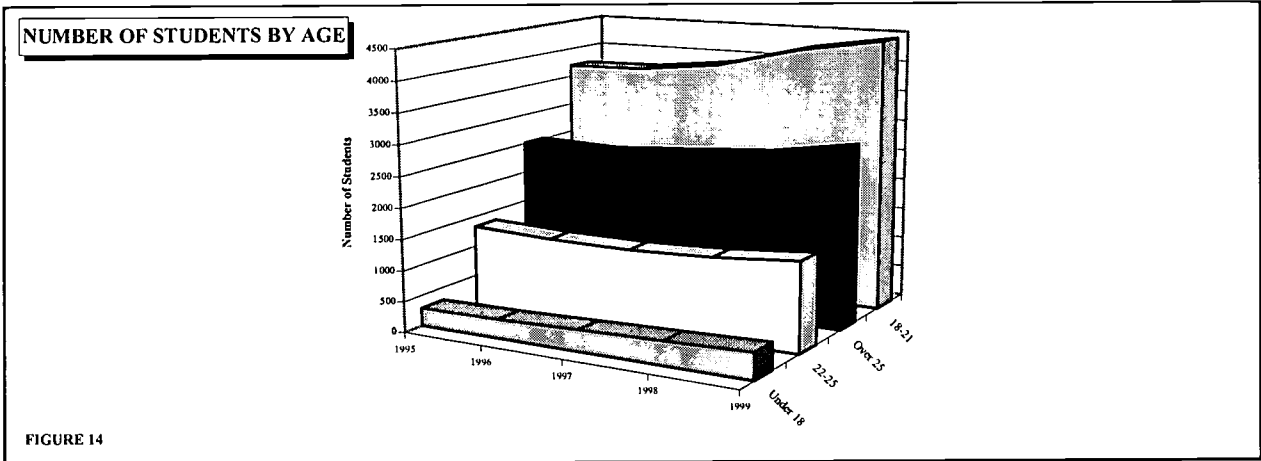

FIGURE 14

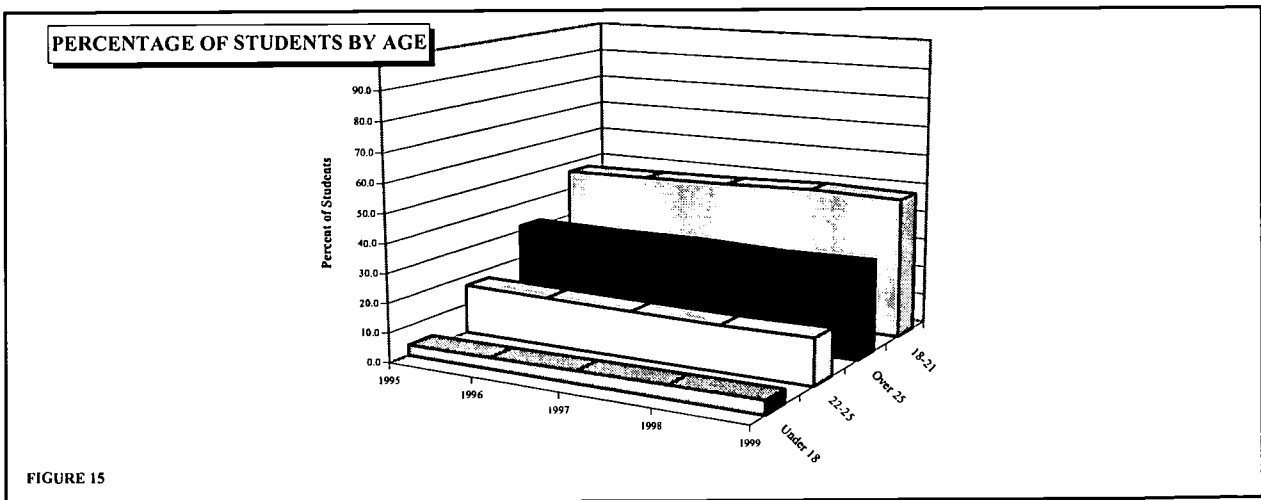

FIGURE 15

HIGHLIGHTS/OBSERVATIONS

BEST COPY AVAILABLE



Student Characteristics and Enrollment Trends 1995 -1999

STUDENTS WITH DISABILITIES

TABLE 8	1994/95		1995/96		1996/97		1997/98		1998/99	
	N	%	N	%	N	%	N	%	N	%
Mobility Impairment	47	8.8	51	9.2	46	8.0	59	8.4	77	9.7
Visual Impairment	8	1.5	7	1.3	12	2.1	13	1.9	12	1.5
Hearing Impairment	12	2.3	11	1.9	12	2.1	17	2.4	20	2.5
Speech & Language Impairment	5	0.9	2	0.4	4	0.7	7	1.0	6	0.8
Learning Disability	342	64.3	304	54.8	291	50.3	320	45.7	329	41.4
Acquired Brain Impairment	28	5.3	28	5.0	24	4.2	26	3.7	36	4.5
Developmentally Delayed Learner	10	1.9	7	1.3	5	0.9	7	1.0	7	0.9
Psychological Disability	23	4.3	34	6.1	35	6.1	49	7.0	71	8.9
Other	57	10.7	111	20.0	149	25.8	202	28.9	237	29.8
TOTAL	532	100.0	555	100.0	578	100.0	700	100.0	795	100.0

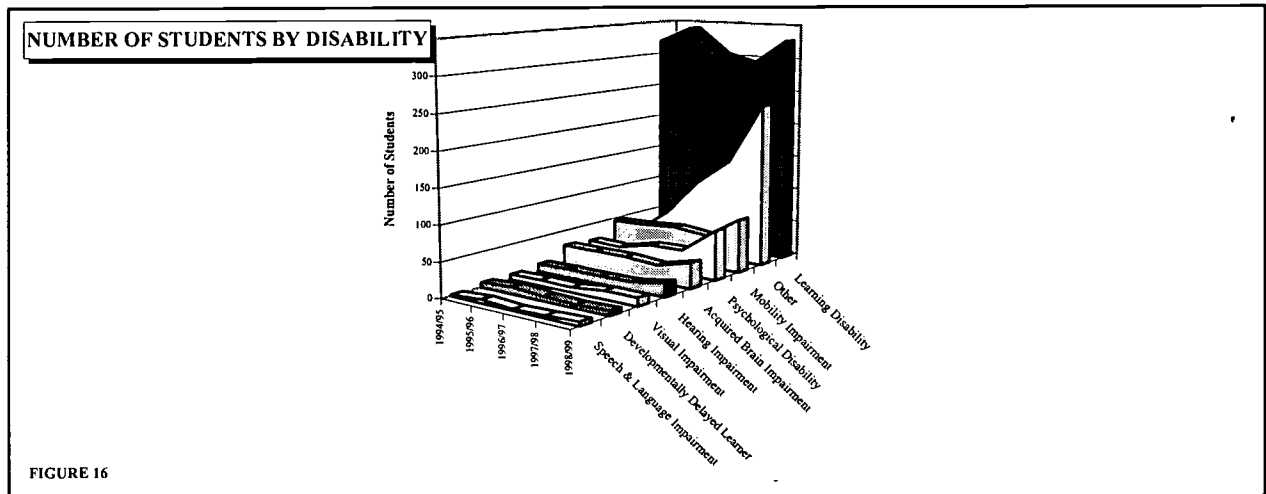

FIGURE 16

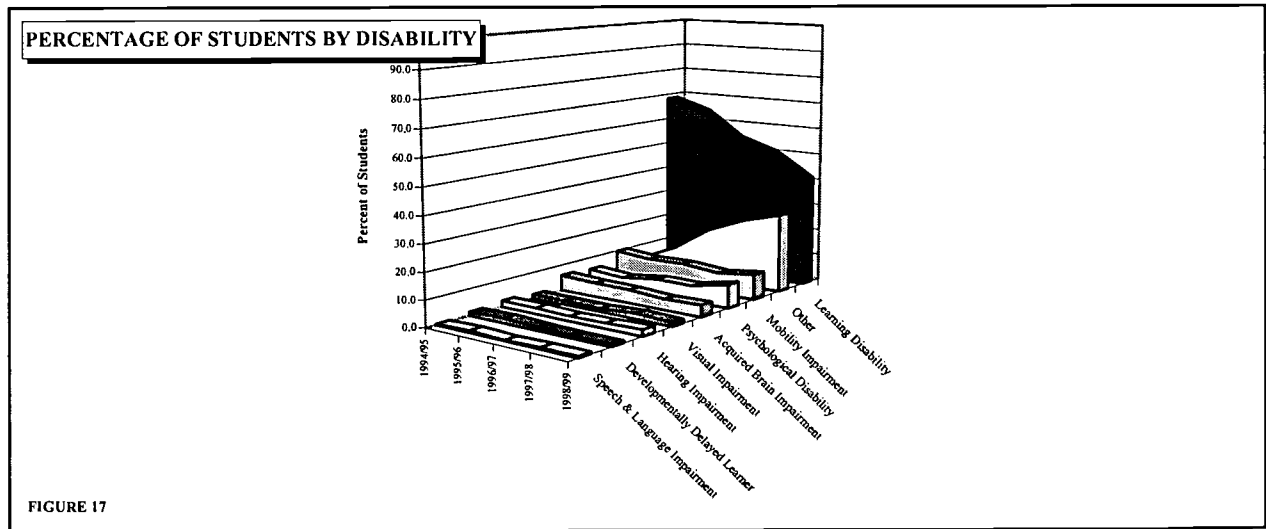

FIGURE 17

HIGHLIGHTS/OBSERVATIONS

➔ The "other" category includes *attention deficit disorder* (ADD), a fast growing category, as well as health related impairments.



Student Characteristics and Enrollment Trends 1995 -1999

LOCAL AND OUT-OF-AREA FIRST-TIME STUDENTS

TABLE 9	1995		1996		1997		1998		1999	
	N	%	N	%	N	%	N	%	N	%
Local (SLO County)	965	54.8	1074	55.1	974	50.5	1126	54.1	1246	58.5
Out of Area	797	45.2	874	44.9	953	49.5	954	45.9	885	41.5
TOTAL	1762	100.0	1948	100.0	1927	100.0	2080	100.0	2131	100.0

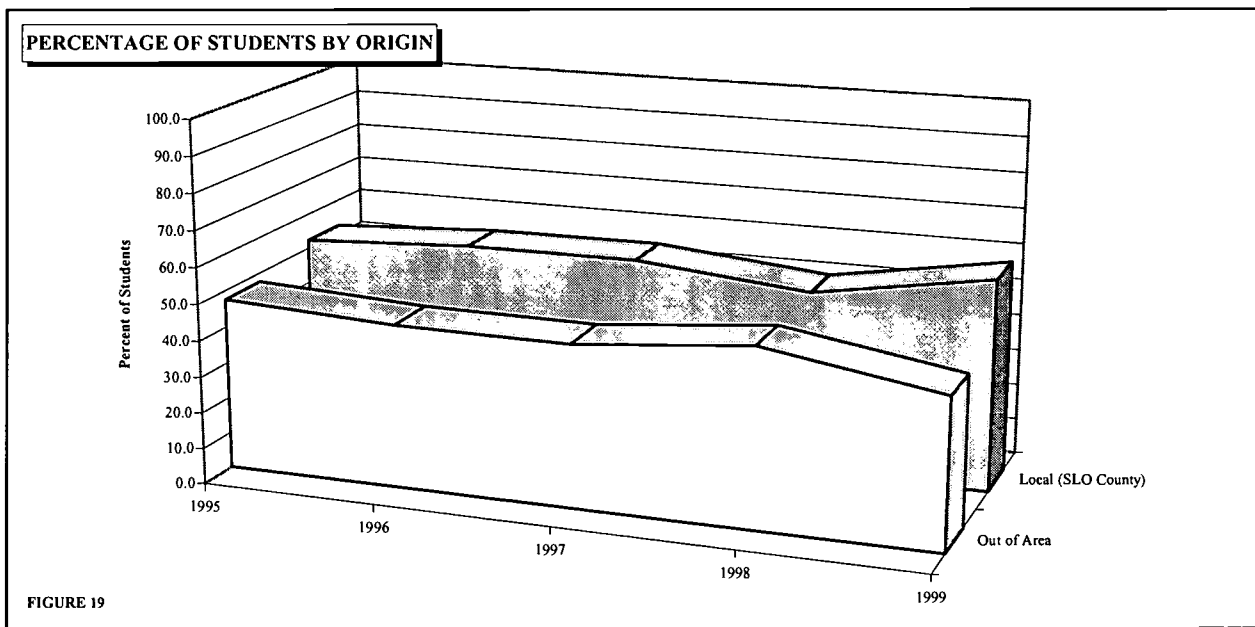
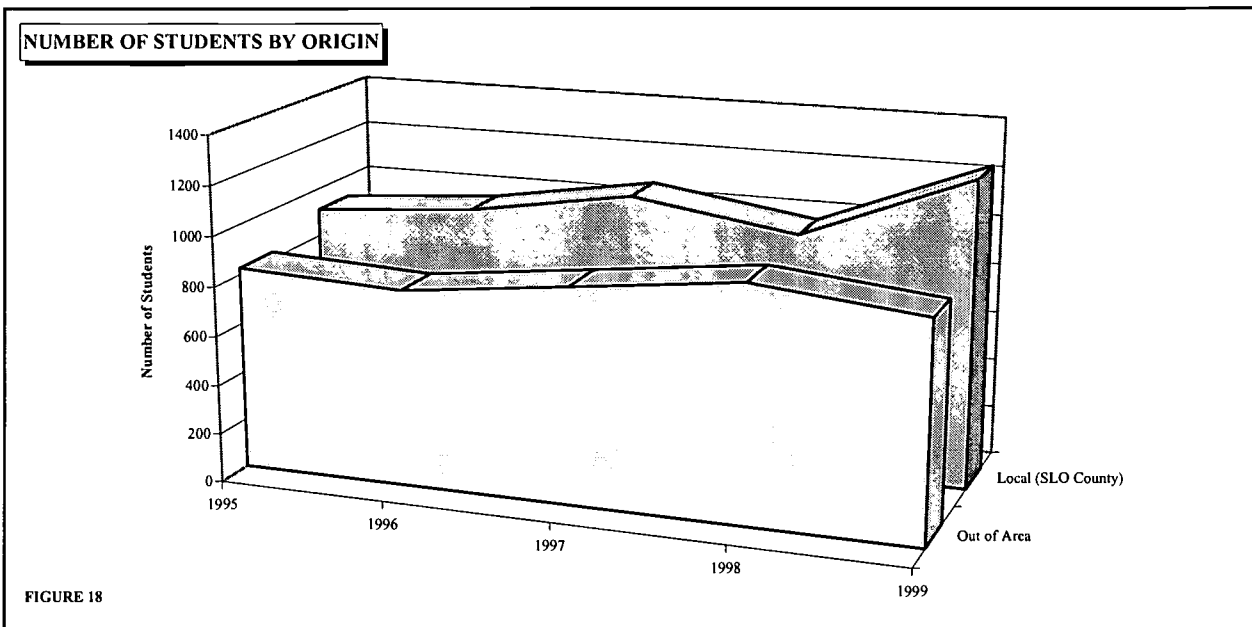

HIGHLIGHTS/OBSERVATIONS

➡ The percentage of "out-of-area" students decreased significantly between 1998 and 1999.



Student Characteristics and Enrollment Trends 1995 -1999

FIRST-TIME STUDENTS FROM LOCAL HIGH SCHOOLS

TABLE 10	1995		1996		1997		1998		1999	
	N	%	N	%	N	%	N	%	N	%
Arroyo Grande	65	11.1	85	13.2	86	12.2	111	13.8	128	15.2
Atascadero	112	19.0	140	21.7	138	19.6	155	19.2	143	17.0
Coast Union	34	5.8	25	3.9	34	4.8	28	3.5	33	3.9
Mission Prep	14	2.4	17	2.6	18	2.6	18	2.2	12	1.4
Morro Bay	93	15.8	104	16.1	83	11.8	103	12.8	100	11.9
Paso Robles	76	12.9	83	12.8	117	16.6	123	15.2	146	17.3
San Luis Obispo	104	17.7	91	14.1	135	19.1	153	19.0	139	16.5
Shandon	8	1.4	6	0.9	10	1.4	7	0.9	2	0.2
Templeton	48	8.2	44	6.8	49	7.0	59	7.3	86	10.2
Continuation High Schools	11	1.9	29	4.5	12	1.7	45	5.6	45	5.3
Other Local High Schools	23	3.9	22	3.4	23	3.3	5	0.6	9	1.1
TOTAL	588	100.0	646	100.0	705	100.0	807	100.0	843	100.0

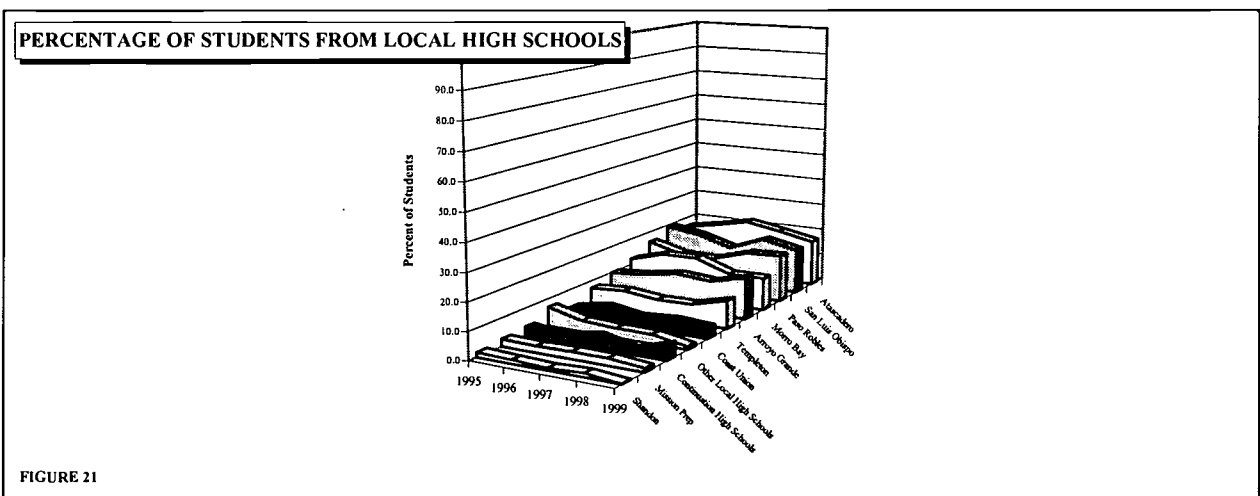
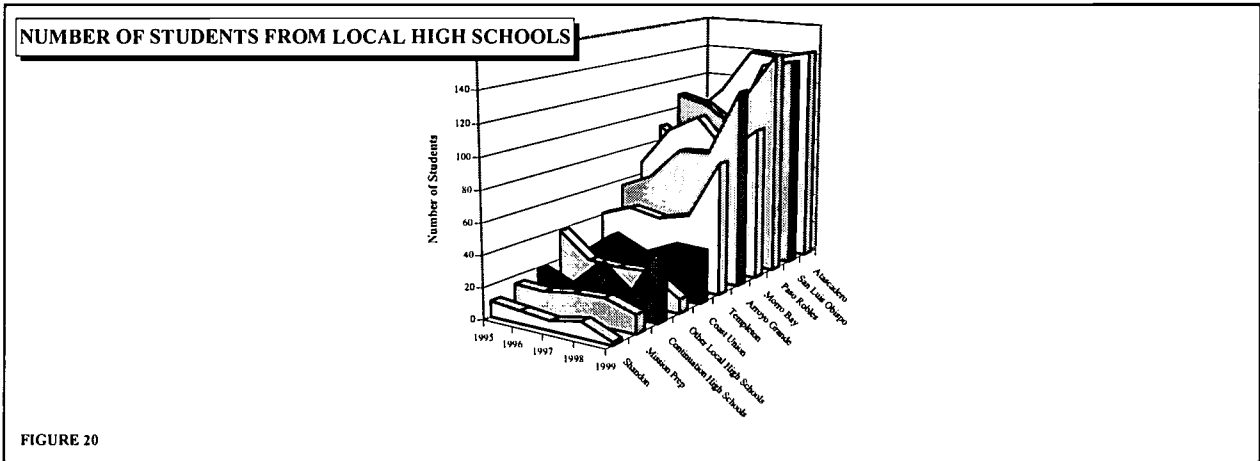

HIGHLIGHTS/OBSERVATIONS

BEST COPY AVAILABLE



Student Characteristics and Enrollment Trends 1995 -1999

STUDENT EDUCATIONAL OBJECTIVE

TABLE 11		1995		1996		1997		1998		1999	
		N	%	N	%	N	%	N	%	N	%
Voc Ed	New Job Skill(s)	720	9.1	712	8.8	714	8.3	730	8.0	752	8.1
	Maintenance of Job Skill(s)	329	4.2	348	4.3	398	4.6	443	4.8	465	5.0
	Occupational Certificate	122	1.5	137	1.7	143	1.7	130	1.4	120	1.3
	VOCATIONAL SUBTOTAL	1171	14.8	1197	14.8	1255	14.5	1303	14.2	1337	14.5
Degree	Occupational Major	317	4.0	314	3.9	321	3.7	298	3.3	284	3.1
	General Education	417	5.3	431	5.3	520	6.0	600	6.6	690	7.5
	Transfer to 4-Year College	3397	43.1	3545	43.8	3803	44.0	3969	43.3	4028	43.6
	DEGREE SUBTOTAL	4131	52.4	4290	53.0	4644	53.7	4867	53.2	5002	54.2
Transfer	Transfer to 4-Year College, No AA/AS	1339	17.0	1351	16.7	1440	16.7	1498	16.4	1340	14.5
	TRANSFER SUBTOTAL	4736	60.0	4896	60.5	5243	60.7	5467	59.7	5368	58.2
Other	High School Diploma	34	0.4	42	0.5	40	0.5	38	0.4	51	0.6
	Personal Interest	304	3.9	350	4.3	395	4.6	498	5.4	576	6.2
	OTHER SUBTOTAL	338	4.3	392	4.8	435	5.0	536	5.9	627	6.8
Unknown	Undeclared	655	8.3	714	8.8	719	8.3	757	8.3	715	7.7
	Unknown	255	3.2	154	1.9	149	1.7	195	2.1	59	0.6
	UNKNOWN GOAL SUBTOTAL	910	11.5	868	10.7	868	10.0	952	10.4	774	8.4

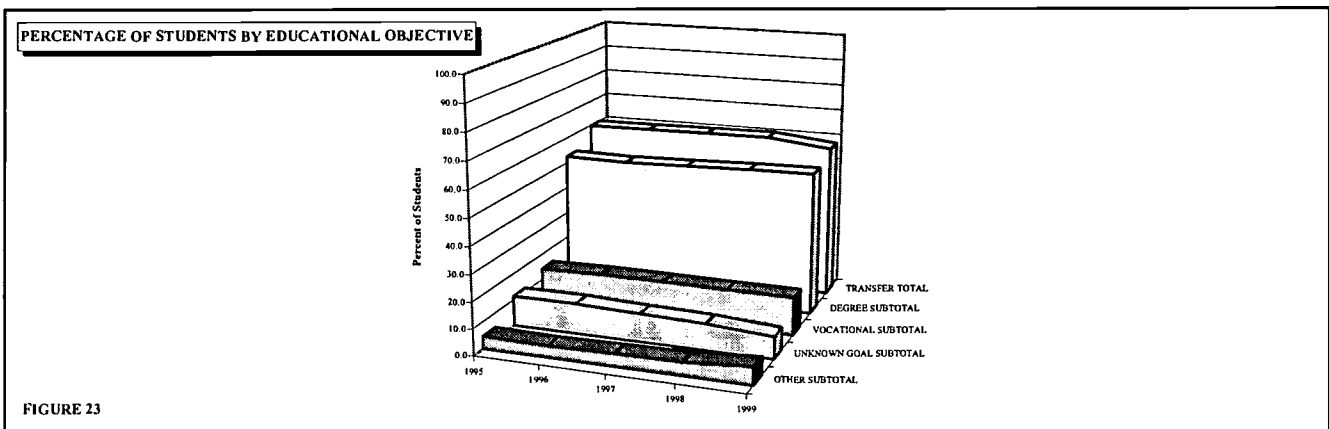
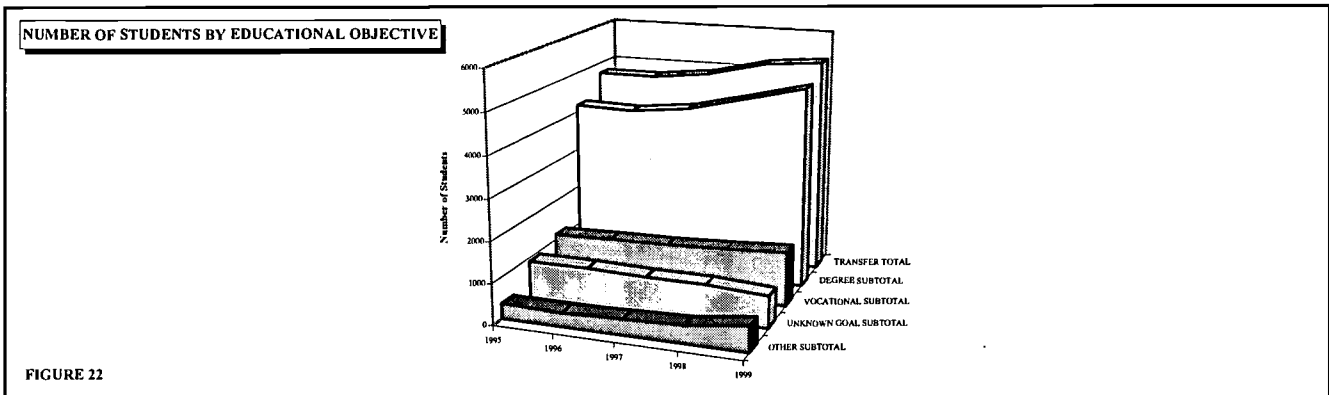

HIGHLIGHTS/OBSERVATIONS

BEST COPY AVAILABLE



Student Characteristics and Enrollment Trends 1995 -1999

AA/AS DEGREE AWARDED TO LOCAL HIGH SCHOOL GRADUATES

TABLE 12	1995		1996		1997		1998		1999	
	N	%	N	%	N	%	N	%	N	%
Arroyo Grande	30	21.6	16	11.8	22	10.2	19	8.6	38	13.1
Atascadero	25	18.0	25	18.4	38	17.6	34	15.4	65	22.3
Coast Union	4	2.9	5	3.7	6	2.8	11	5.0	11	3.8
Mission Prep	2	1.4	6	4.4	6	2.8	3	1.4	1	0.3
Morro Bay	20	14.4	18	13.2	35	16.2	39	17.6	43	14.8
Paso Robles	21	15.1	12	8.8	26	12.0	28	12.7	34	11.7
San Luis Obispo	24	17.3	40	29.4	54	25.0	50	22.6	55	18.9
Shandon	1	0.7	6	4.4	1	0.5	2	0.9	3	1.0
Templeton	4	2.9	0	0.0	13	6.0	16	7.2	18	6.2
Continuation High Schools	5	3.6	5	3.7	3	1.4	8	3.6	8	2.7
Other Local High Schools	3	2.2	3	2.2	12	5.6	11	5.0	15	5.2
TOTAL	139	100.0	136	100.0	216	100.0	221	100.0	291	100.0

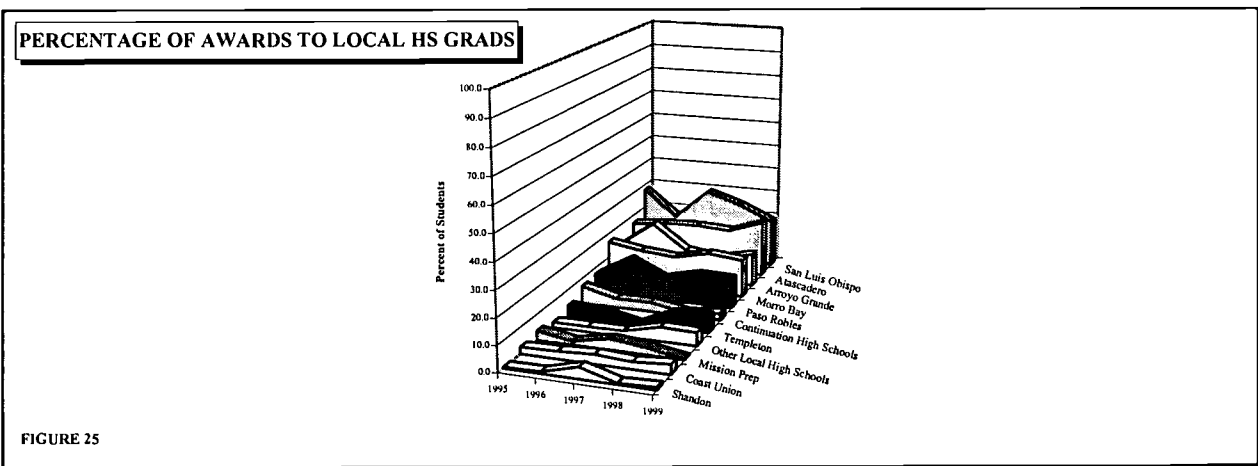
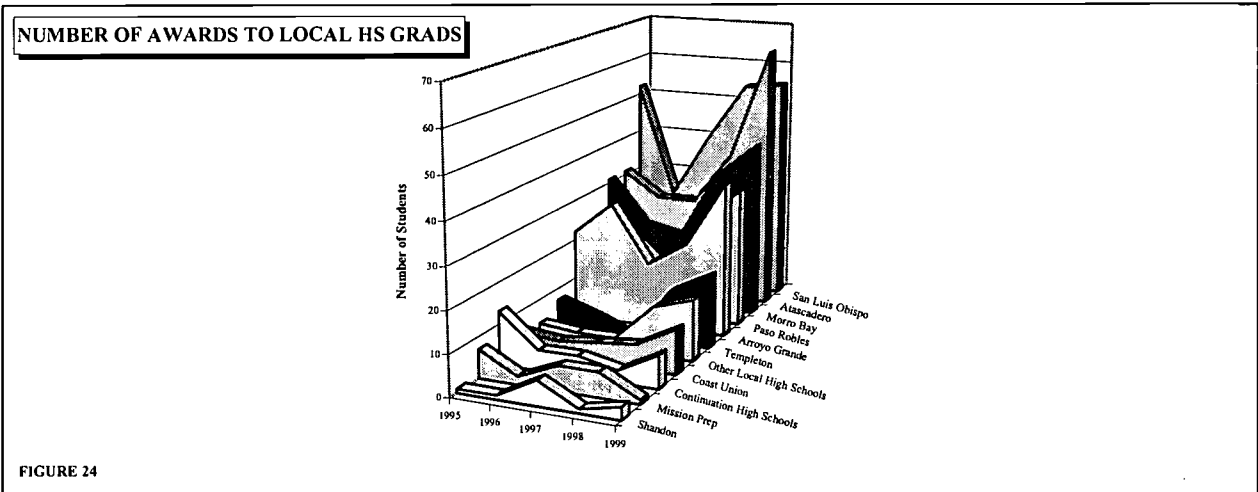

HIGHLIGHTS/OBSERVATIONS

BEST COPY AVAILABLE

ENROLLMENT STATISTICS BY CUESTA COLLEGE EDUCATIONAL REGION 1998-1999

Enrollment Statistics by Cuesta College Educational Region for 1998-1999
STUDENT ENROLLMENT STATUS

TABLE 13	1998						1999					
	SLO		North		South		SLO		North		South	
	N	%	N	%	N	%	N	%	N	%	N	%
First-Time Students	1795	22.3	350	27.1	98	26.3	1768	22.4	418	26.9	102	26.6
New Transfer Students	1117	13.9	138	10.7	88	23.7	1127	14.3	169	10.9	70	18.2
Returning Transfer Students	229	2.8	52	4.0	16	4.3	208	2.6	38	2.4	17	4.4
Returning Students	642	8.0	199	15.4	29	7.8	607	7.7	224	14.4	29	7.6
Continuing Students	4226	52.6	529	40.9	140	37.6	4167	52.8	695	44.7	164	42.7
Undeclared/Unknown	30	0.4	25	1.9	1	0.3	8	0.1	10	0.6	2	0.5
TOTAL	8039	100.0	1293	100.0	372	100.0	7885	100.0	1554	100.0	384	100.0

STUDENT ENROLLMENT BY DAY/EVENING STATUS

TABLE 14	1998						1999					
	SLO		North		South		SLO		North		South	
	N	%	N	%	N	%	N	%	N	%	N	%
Day Only Students	3614	45.0	240	18.6	0	0.0	3770	47.8	461	29.7	22	5.7
Day and Evening Students	3001	37.3	419	32.4	203	54.6	2734	34.7	356	22.9	6	1.6
Evening Only Students	1424	17.7	634	49.0	169	45.4	1381	17.5	737	47.4	356	92.7
TOTAL	8039	100.0	1293	100.0	372	100.0	7885	100.0	1554	100.0	384	100.0

STUDENT COURSE LOAD

TABLE 15	1998						1999					
	SLO		North		South		SLO		North		South	
	N	%	N	%	N	%	N	%	N	%	N	%
6 or fewer units	2219	27.6	671	51.9	131	35.2	2087	26.5	722	46.5	147	38.3
6.1-11.9 units	1977	24.6	279	21.6	82	22.0	1869	23.7	377	24.3	88	22.9
12-15 units	3370	41.9	308	23.8	145	39.0	3345	42.4	422	27.2	138	35.9
More than 15 units	473	5.9	35	2.7	14	3.8	584	7.4	33	2.1	11	2.9
TOTAL	8039	100.0	1293	100.0	372	100.0	7885	100.0	1554	100.0	384	100.0

STUDENT LEVEL-UNITS OR DEGREE(S) COMPLETED

TABLE 16	1998						1999					
	SLO		North		South		SLO		North		South	
	N	%	N	%	N	%	N	%	N	%	N	%
Fewer than 30 Units	5372	66.8	905	70.0	279	75.0	5172	65.6	1091	70.2	278	72.4
30-59.9 Units	1429	17.8	174	13.5	36	9.7	1365	17.3	235	15.1	49	12.8
60 or more (No Degree)	391	4.9	51	3.9	9	2.4	402	5.1	55	3.5	12	3.1
AA/AS Degree	550	6.8	106	8.2	32	8.6	589	7.5	99	6.4	30	7.8
BA/BS Degree or higher	297	3.7	57	4.4	16	4.3	357	4.5	74	4.8	15	3.9
TOTAL	8039	100.0	1293	100.0	372	100.0	7885	100.0	1554	100.0	384	100.0

HIGHLIGHTS/OBSERVATIONS

- ➡ The North County campus grew by 261 students in its second year of operation.
- ➡ The percentage of day only students grew from 18.6 to 29.7 percent in 1999.
- ➡ The vast majority of students, regardless of campus, have completed fewer than 30 units.

BEST COPY AVAILABLE



Enrollment Statistics by Cuesta College Educational Region for 1998-1999

STUDENT GENDER

TABLE 17*	1998						1999					
	SLO		North		South		SLO		North		South	
	N	%	N	%	N	%	N	%	N	%	N	%
Female	4134	51.4	864	66.8	219	58.9	4147	52.6	1052	67.7	230	59.9
Male	3905	48.6	429	33.2	153	41.1	3738	47.4	502	32.3	154	40.1
TOTAL	8039	100.0	1293	100.0	372	100.0	7885	100.0	1554	100.0	384	100.0

* Unknowns were divided proportionately within the male and female categories

STUDENT ETHNICITY

TABLE 18	1998						1999					
	SLO		North		South		SLO		North		South	
	N	%	N	%	N	%	N	%	N	%	N	%
American Indian	100	1.2	22	1.7	3	0.8	107	1.4	22	1.4	0	0.0
Asian	277	3.4	33	2.6	9	2.4	273	3.5	32	2.1	7	1.8
Black	145	1.8	25	1.9	3	0.8	122	1.5	27	1.7	10	2.6
Filipino	119	1.5	6	0.5	4	1.1	126	1.6	9	0.6	10	2.6
Hispanic	977	12.2	178	13.8	50	13.4	980	12.4	281	18.1	58	15.1
White	6131	76.3	980	75.8	286	76.9	5990	76.0	1131	72.8	278	72.4
Other/Undeclared	290	3.6	49	3.8	17	4.6	287	3.6	52	3.3	21	5.5
TOTAL	8039	100.0	1293	100.0	372	100.0	7885	100.0	1554	100.0	384	100.0

STUDENT AGE

TABLE 19	1998						1999					
	SLO		North		South		SLO		North		South	
	N	%	N	%	N	%	N	%	N	%	N	%
17 and under	368	4.6	72	5.6	26	7.0	333	4.2	82	5.3	52	13.5
18 only	1134	14.1	164	12.7	50	13.4	1132	14.4	188	12.1	42	10.9
19 only	1280	15.9	113	8.7	51	13.7	1178	14.9	132	8.5	31	8.1
20-21	1770	22.0	166	12.8	65	17.5	1757	22.3	211	13.6	67	17.4
22-25	1272	15.8	155	12.0	57	15.3	1287	16.3	181	11.6	69	18.0
26-30	650	8.1	137	10.6	35	9.4	612	7.8	160	10.3	43	11.2
31-40	788	9.8	238	18.4	42	11.3	742	9.4	287	18.5	39	10.2
41-50	525	6.5	166	12.8	31	8.3	581	7.4	226	14.5	32	8.3
51-65	201	2.5	68	5.3	13	3.5	204	2.6	75	4.8	6	1.6
Over 65	46	0.6	14	1.1	2	0.5	58	0.7	12	0.8	3	0.8
Unknown	5	0.1	0	0.0	0	0.0	1	0.0	0	0.0	0	0.0
TOTAL	8039	100.0	1293	100.0	372	100.0	7885	100.0	1554	100.0	384	100.0

BEST COPY AVAILABLE

HIGHLIGHTS/OBSERVATIONS

- ⇒ Two-thirds of the students on the North County campus are female.
- ⇒ The percentage of Hispanic students at the North County campus increased by 4.3 percentage points

Enrollment Statistics by Cuesta College Educational Region for 1998-1999
LOCAL AND OUT-OF-AREA FIRST-TIME STUDENTS

TABLE 20	1998						1999					
	SLO		North		South		SLO		North		South	
	N	%	N	%	N	%	N	%	N	%	N	%
Local (SLO County)							932	52.7	343	82.1	91	89.2
Out of Area							836	47.3	75	17.9	11	10.8
TOTAL							1768	100.0	418	100.0	102	100.0

FIRST-TIME STUDENTS FROM LOCAL HIGH SCHOOLS

TABLE 21	1998						1999					
	SLO		North		South		SLO		North		South	
	N	%	N	%	N	%	N	%	N	%	N	%
Arroyo Grande	103	15.3	2	1.1	37	88.1	102	15.2	1	0.5	53	94.6
Atascadero	138	20.5	37	19.9	1	2.4	115	17.2	34	15.7	0	0.0
Coast Union	28	4.2	1	0.5	0	0.0	32	4.8	1	0.5	0	0.0
Mission Prep	17	2.5	2	1.1	0	0.0	12	1.8	0	0.0	0	0.0
Morro Bay	103	15.3	1	0.5	0	0.0	99	14.8	3	1.4	1	1.8
Paso Robles	56	8.3	94	50.5	0	0.0	73	10.9	113	52.3	1	1.8
San Luis Obispo	151	22.4	2	1.1	2	4.8	137	20.4	2	0.9	0	0.0
Shandon	2	0.3	5	2.7	0	0.0	1	0.1	1	0.5	0	0.0
Templeton	40	5.9	27	14.5	1	2.4	54	8.1	51	23.6	0	0.0
Continuation High Schools	24	3.6	5	2.7	1	2.4	37	5.5	9	4.2	1	1.8
Other Local High Schools	11	1.6	10	5.4	0	0.0	8	1.2	1	0.5	0	0.0
TOTAL	673	100.0	186	100.0	42	100.0	670	100.0	216	100.0	56	100.0

BEST COPY AVAILABLE

HIGHLIGHTS/OBSERVATIONS

- ⇒ The vast majority of Cuesta's "out-of-area" students attend the San Luis Obispo campus.
- ⇒ Local high schools contribute students to a campus in direct proportion to their proximity to that campus.



Enrollment Statistics by Cuesta College Educational Region for 1998-1999

STUDENT EDUCATIONAL OBJECTIVE

TABLE 22		1998						1999					
		SLO		North		South		SLO		North		South	
		N	%	N	%	N	%	N	%	N	%	N	%
Voc ED	New Job Skill(s)	608	7.6	147	11.4	28	7.5	610	7.7	175	11.3	23	6.0
	Maintenance of Job Skill(s)	325	4.0	117	9.0	21	5.6	356	4.5	113	7.3	21	5.5
	Occupational Certificate	110	1.4	22	1.7	5	1.3	104	1.3	24	1.5	4	1.0
	VOCATIONAL SUBTOTAL	1043	13.0	286	22.1	54	14.5	1070	13.6	312	20.1	48	12.5
Degree	Occupational Major	253	3.1	56	4.3	9	2.4	231	2.9	61	3.9	10	2.6
	General Education	484	6.0	129	10.0	38	10.2	513	6.5	179	11.5	45	11.7
	Transfer to 4-Year College	3611	44.9	447	34.6	152	40.9	3628	46.0	526	33.8	157	40.9
	DEGREE SUBTOTAL	4348	54.1	632	48.9	199	53.5	4372	55.4	766	49.3	212	55.2
Transfer	Transfer to 4-Year College, No AA/AS	1418	17.6	109	8.4	63	16.9	1234	15.6	136	8.8	55	14.3
	TRANSFER SUBTOTAL	5029	62.6	556	43.0	215	57.8	4862	61.7	662	42.6	212	55.2
Other	High School Diploma	27	0.3	9	0.7	5	1.3	35	0.4	10	0.6	10	2.6
	Personal Interest	411	5.1	81	6.3	20	5.4	460	5.8	113	7.3	21	5.5
	OTHER SUBTOTAL	438	5.4	90	7.0	25	6.7	495	6.3	123	7.9	31	8.1
Unknown	Undeclared	639	7.9	134	10.4	24	6.5	583	7.4	144	9.3	30	7.8
	Unknown	153	1.9	42	3.2	7	1.9	40	0.5	18	1.2	2	0.5
	UNKNOWN GOAL SUBTOTAL	792	9.9	176	13.6	31	8.3	623	7.9	162	10.4	32	8.3

BEST COPY AVAILABLE

HIGHLIGHTS/OBSERVATIONS

➡ The percentage of students whose initial educational objective is vocational in nature declined by two percentage points at the North County campus.

APPENDICES



Student Characteristics and Enrollment Trends 1995-1999

APPENDIX I: ENROLLMENT HISTORY - All Sites

Year	N	N Change	% Change		Year	N	N Change	% Change		Year	N	N Change	% Change
1965	1670				1977	5541	-54	-1.0		1989	7915	407	5.4
1966	2062	392	23.5		1978	4653	-888	-16.0		1990	7966	51	0.6
1967	2409	347	16.8		1979	5092	439	9.4		1991	7739	-227	-2.8
1968	2722	313	13.0		1980	5933	841	16.5		1992	8004	265	3.4
1969	2843	121	4.4		1981	6320	387	6.5		1993	7435	-569	-7.1
1970	3448	605	21.3		1982	6108	-212	-3.4		1994	7963	528	7.1
1971	3980	532	15.4		1983	5662	-446	-7.3		1995	7880	-83	-1.0
1972	3749	-231	-5.8		1984	5424	-238	-4.2		1996	8126	246	3.1
1973	4125	376	10.0		1985	5953	529	9.8		1997	8656	530	6.5
1974	4604	479	11.6		1986	6519	566	9.5		1998	9156	500	5.8
1975	5518	914	19.9		1987	7029	510	7.8		1999	9229	73	0.8
1976	5595	77	1.4		1988	7508	479	6.8		2000			

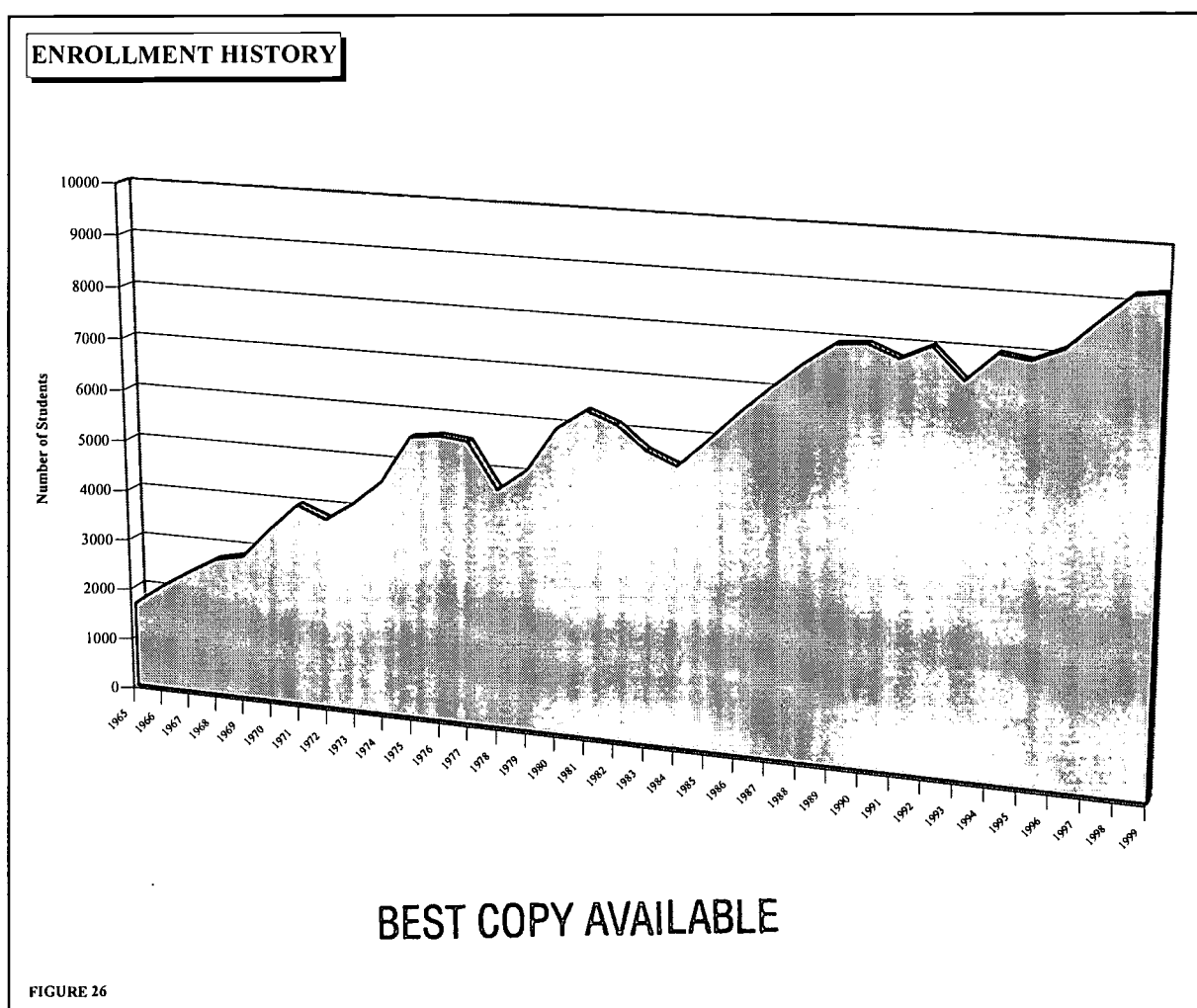

HIGHLIGHTS/OBSERVATIONS

⇒ Enrollment growth has slowed considerably between 1998 and 1999.



Student Characteristics and Enrollment Trends 1995 -1999

APPENDIX II: LOCAL RESIDENCY OF CUESTA STUDENTS - All Sites (unduplicated)

APPENDIX II	1997		1998		1999	
	N	%	N	%	N	%
City of San Luis Obispo	3225	42.1	3108	38.7	3189	38.7
Coast	1146	15.0	1200	14.9	1222	14.8
South Coast	879	11.5	1027	12.8	951	11.6
North County Coastal	280	3.7	290	3.6	307	3.7
North County Inland	2052	26.8	2337	29.1	2447	29.7
Outside of San Luis Obispo County	72	0.9	68	0.8	117	1.4
SUBTOTAL	7654	100.0	8030	100.0	8233	100.0
Unreported Local Address	1003	11.6	1071	11.8	996	10.8
TOTAL	8657	100.0	9101	100.0	9229	100.0

FIGURE 27

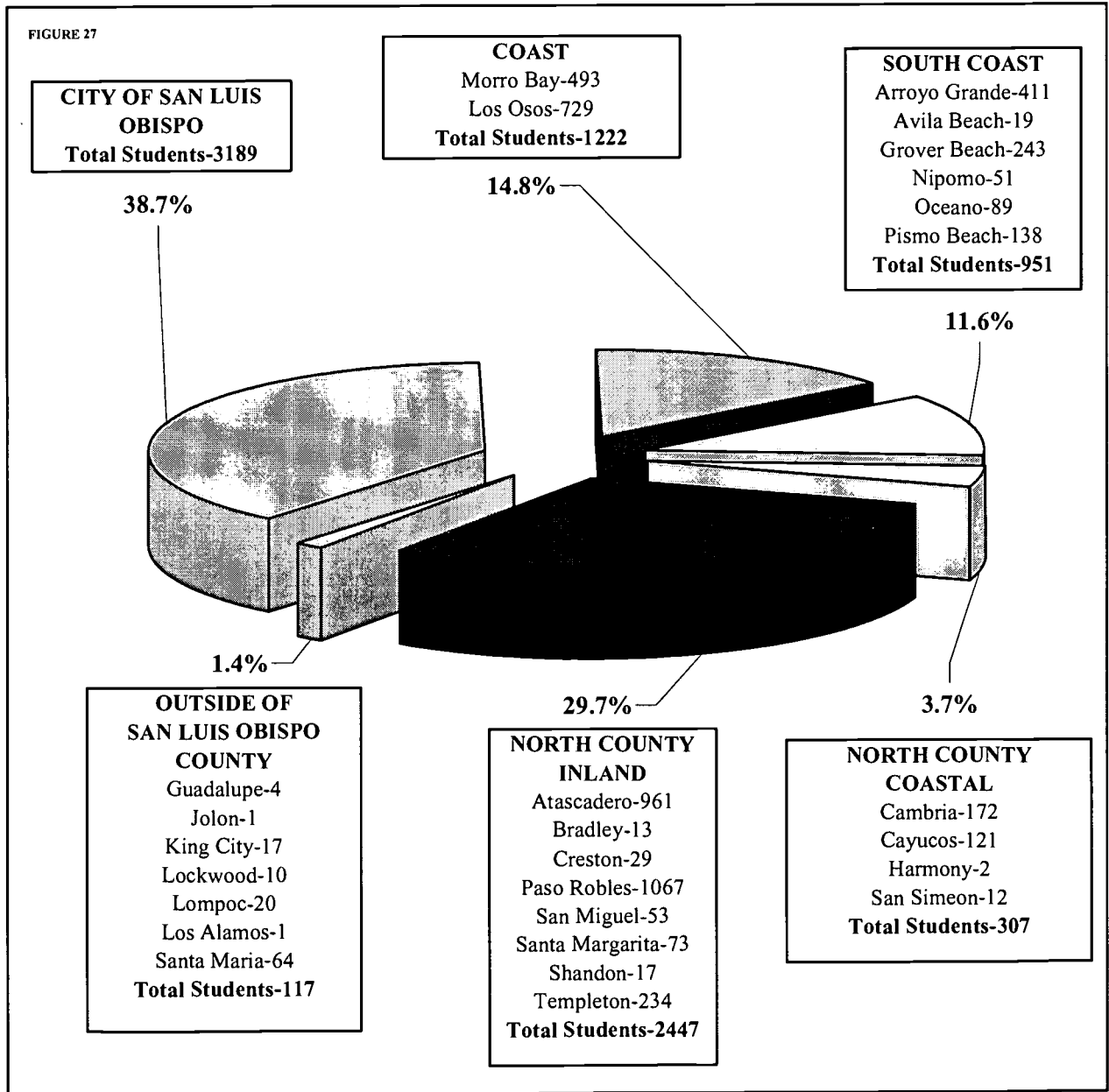



APPENDIX III: LOCAL RESIDENCY OF STUDENTS ATTENDING THE SAN LUIS OBISPO CAMPUS

APPENDIX III	1999	
	N	%
City of San Luis Obispo	3165	45.8
Coast	1214	17.6
South Coast	802	11.6
North County Coastal	301	4.4
North County Inland	1324	19.2
Outside of San Luis Obispo County	107	1.5
SUBTOTAL	6913	100.0
Unreported Local Address	972	12.3
TOTAL	7885	100.0

FIGURE 28

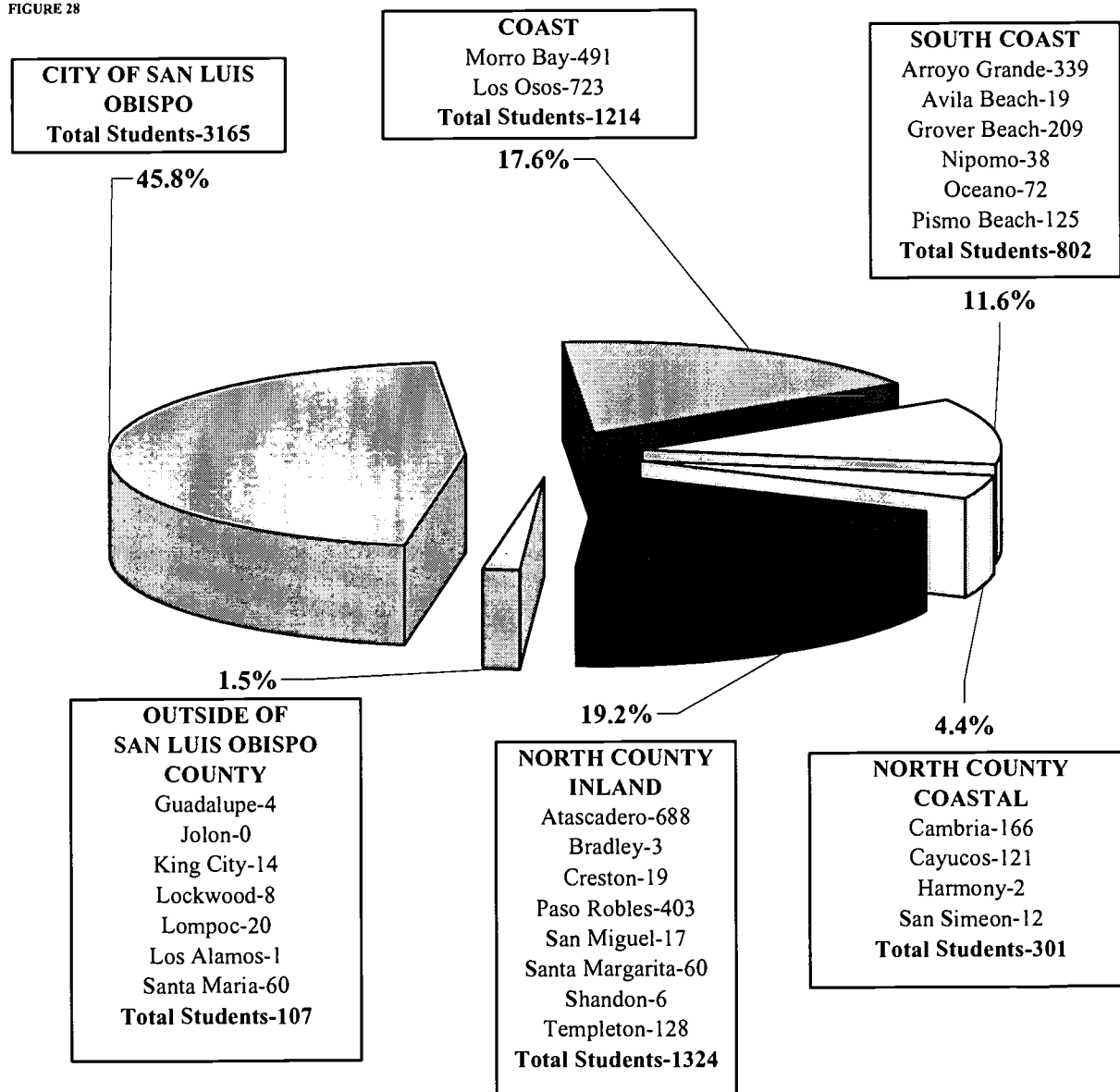



Student Characteristics and Enrollment Trends 1995 -1999

APPENDIX IV: LOCAL RESIDENCY OF STUDENTS ATTENDING THE NORTH COUNTY CAMPUS

APPENDIX IV	1999	
	N	%
City of San Luis Obispo	29	1.9
Coast	15	1.0
South Coast	5	0.3
North County Coastal	10	0.7
North County Inland	1447	95.5
Outside of San Luis Obispo County	9	0.6
SUBTOTAL	1515	100.0
Unreported Local Address	39	2.5
TOTAL	1554	100.0

FIGURE 29

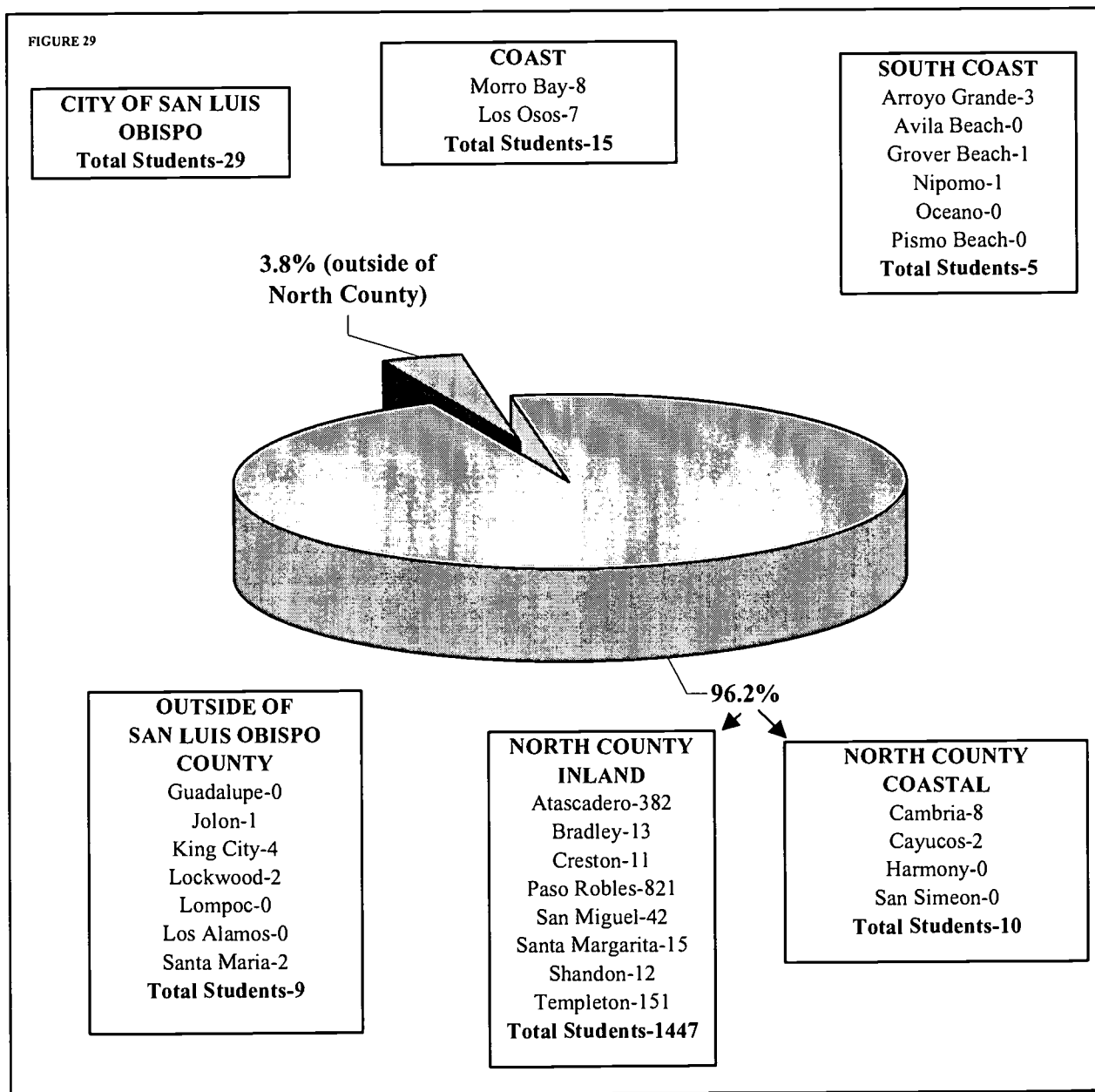



APPENDIX V: LOCAL RESIDENCY OF STUDENTS ATTENDING THE SOUTH COUNTY CENTER

APPENDIX V	1999	
	N	%
City of San Luis Obispo	40	11.5
Coast	5	1.4
South Coast	289	82.8
North County Coastal	1	0.3
North County Inland	5	1.4
Outside of San Luis Obispo County	9	2.6
SUBTOTAL	349	100.0
Unreported Local Address	35	9.1
TOTAL	384	100.0

FIGURE 30

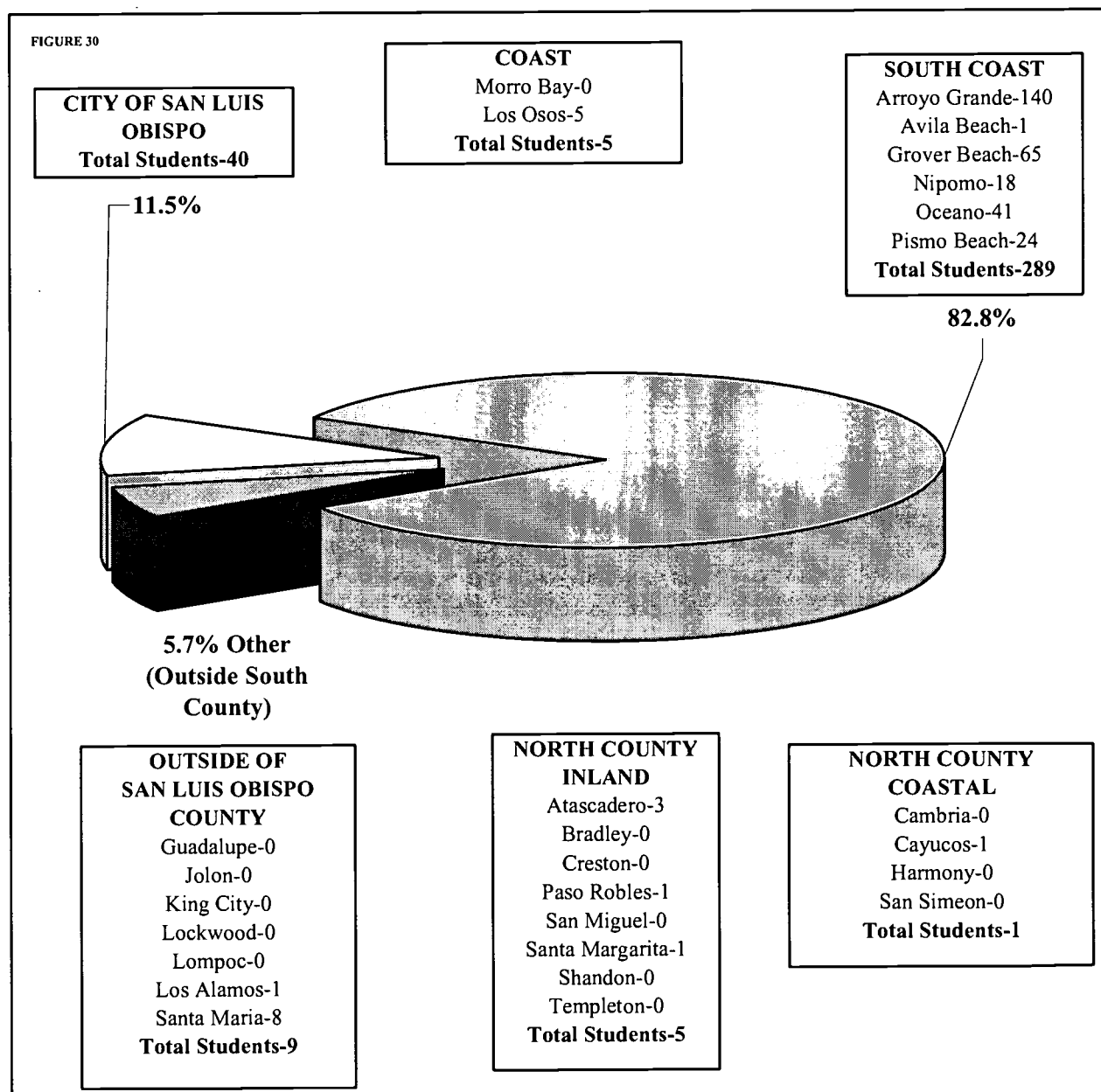



APPENDIX VI: REGIONAL ENROLLMENT COMPARISONS

FIGURE 31

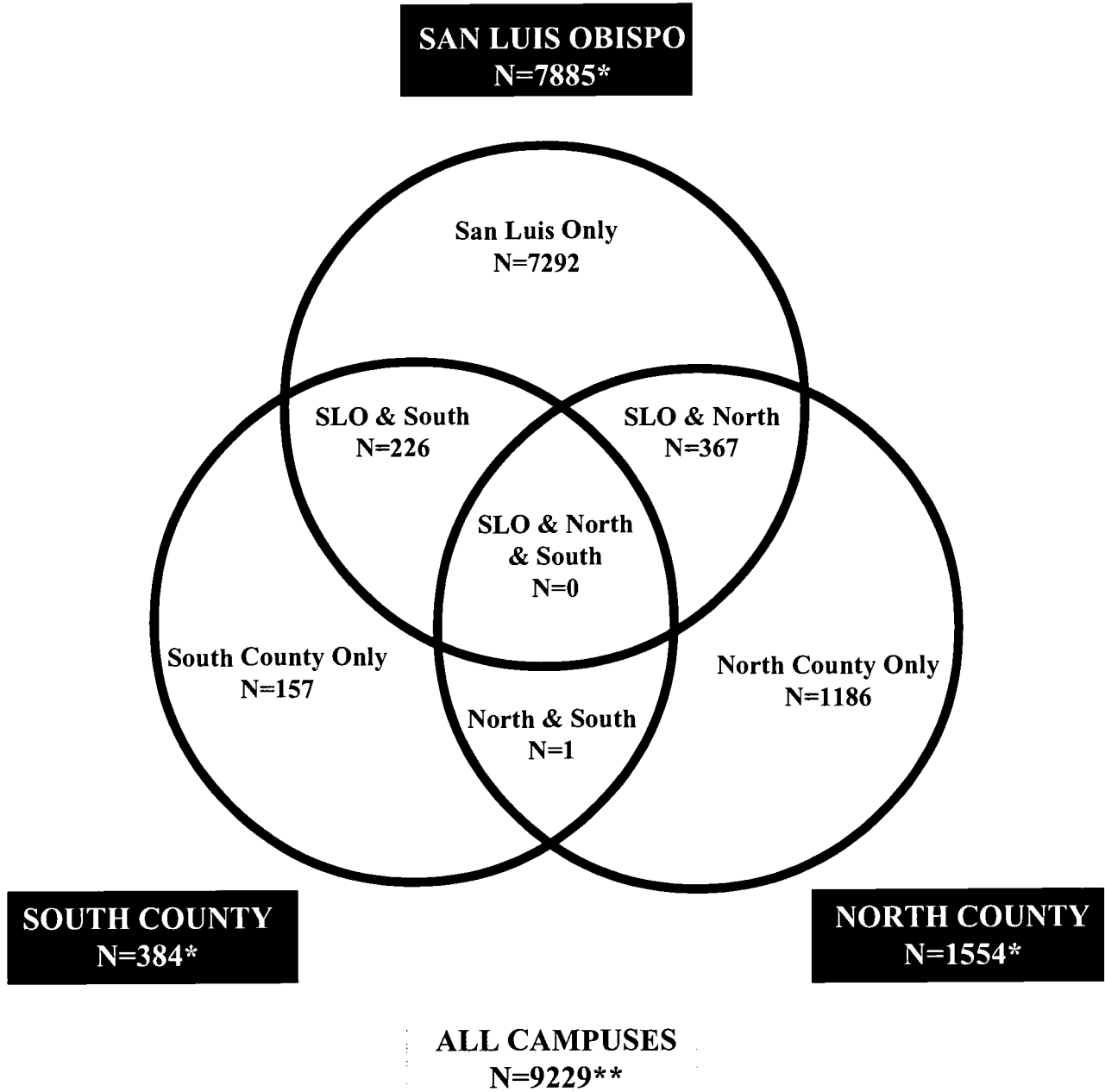

BEST COPY AVAILABLE

HIGHLIGHTS/OBSERVATIONS

This Diagram shows the many possibilities open to students with three campus sites available.

* This figure represents the duplicated number of students enrolled in at least one course at the specified location.
 ** This figure represents the unduplicated number of students enrolled in at least one course at any location.



GLOSSARY OF TERMS

ACQUIRED BRAIN IMPAIRMENT (ABI): A verified deficit in brain functioning which results in a total or partial loss of cognitive, communicative, motor, psycho-social and/or sensory-perceptual abilities.

AMERICAN INDIAN: Ethnic category that includes indigenous tribes of the continental U.S. and Alaska.

ASIAN AND PACIFIC RIM: Ethnic category which includes sub-groups of Asians (Chinese, Japanese, Korean, Laotian, Cambodian, Vietnamese, East Indian and other Asians) and subgroups of Pacific Rim cultures (Guamanian, Hawaiian, Samoan and other Pacific Islanders).

ASSOCIATE DEGREE: TRANSFER TO FOUR-YEAR COLLEGE: These students intend to complete the A.A./A.S. degree requirements in addition to those general education requirements of a four-year college necessary for transfer.

ATTENTION DEFICIT/HYPERACTIVITY DISORDER: A persistent pattern of inattention and/or hyperactivity/impulsivity that is more frequent and severe than is typically observed in others of the same age.

CONTINUATION HIGH SCHOOLS: These schools include: Atascadero Adult, Liberty, Lopez, Oak Hills, Pacific Beach and San Luis Adult Evening.

CONTINUING STUDENTS: Students who were enrolled at Cuesta College the previous semester.

DAY AND EVENING STUDENTS: Students enrolled in both day and evening classes.

DAY STUDENTS: Students enrolled in classes that begin prior to 4:00 p.m.

DEVELOPMENTALLY DELAYED LEARNER (DDL): Students with below-average intellectual functioning.

EVENING STUDENTS: Students enrolled only in classes that begin at or after 4:00 p.m.

FIRST-TIME STUDENTS: Students who have never attended college-usually recent high school graduates, who can be local or out-of-area students.

HEARING IMPAIRMENT: A total or partial loss of hearing function, which impedes the communication process essential to language usage.

HISPANIC: Ethnic category that includes Mexican-Chicano, Mexican-American, Central American, South American and other Hispanic groups.

LEARNING DISABILITY: Students with average to above-average intellectual ability, but with a severe information processing deficit.

MOBILITY IMPAIRMENT: A serious limitation in locomotion or motor function.

NEW LOCAL STUDENT: Any new student who reported living in San Luis Obispo County for a year or more.

NEW OUT-OF-AREA STUDENT: Any new student who reported living outside of San Luis Obispo County during the previous year.

NEW TRANSFER STUDENT: Student who has attended or is attending another college.

NORTH COUNTY CAMPUS: Comprises classes taught at the following locations: North County campus (at Paso Robles), Paso Robles High School and Mid-State Fairground.

OTHER DISABILITY: Includes students with disabilities who do not fall into any of the categories described and who indicate a need for support services or instruction. Students with attention deficit/hyperactivity disorders and students with a previously identified learning disability are also included.

BEST COPY AVAILABLE



GLOSSARY OF TERMS

OTHER HIGH SCHOOLS: Central Coast Christian, Grace Christian of Paso Robles, North County Christian, Paso Robles School for Boys and San Luis Christian Academy.

OCCUPATIONAL CERTIFICATES: Certificates of Completion for specific vocational skills and Certificates of Proficiency for completion of a wider area of vocational study.

OCCUPATIONAL MAJOR: Usually a major field of study which terminates with the completion of an A.A./A.S. degree (e.g. Automotive Technology, Library Technology).

PERSONAL INTEREST: Courses taken for personal growth and enjoyment.

PHYSICAL DISABILITY (MOBILITY/VISUAL): Student who is visually impaired (e.g., blind, or has a serious limitation in locomotion or motor function requiring wheelchair or crutches).

PSYCHOLOGICAL DISABILITY: Student who has a persistent psychological or psychiatric emotional or mental illness.

RETURNING STUDENT: Student who has previously attended Cuesta College, but not during the last semester.

RETURNING TRANSFER STUDENT: Student who has attended another college since leaving Cuesta College.

SAN LUIS OBISPO CAMPUS: Comprises courses taught at the following locations: Cuesta College main on Highway 1, Cal Poly, Atascadero State Hospital, Cambria, Sierra Vista Hospital, and El Paso de Robles Boys School.

SOUTH COUNTY SITE: Comprises courses taught at Arroyo Grande High School.

SPEECH AND LANGUAGE IMPAIRMENT: One or more speech/language disorders of voice, articulation, rhythm, and/or the receptive, and expressive processes of language.

TRANSFER SUBTOTAL: In Table 11, the sum of all students with a transfer objective (including those with an objective to obtain an A.A./A.S. Degree and those without such an objective).

TRANSFER TO FOUR-YEAR COLLEGE, NO A.A./A.S.: This term refers to students who are not planning to complete requirements for an A.A./A.S. degree, but intend to complete the general education requirements for transfer to a four-year college.

VISUAL IMPAIRMENT: A total or partial loss of sight.

BEST COPY AVAILABLE



U.S. Department of Education
Office of Educational Research and Improvement (OERI)
National Library of Education (NLE)
Educational Resources Information Center (ERIC)



NOTICE

REPRODUCTION BASIS



This document is covered by a signed "Reproduction Release (Blanket) form (on file within the ERIC system), encompassing all or classes of documents from its source organization and, therefore, does not require a "Specific Document" Release form.



This document is Federally-funded, or carries its own permission to reproduce, or is otherwise in the public domain and, therefore, may be reproduced by ERIC without a signed Reproduction Release form (either "Specific Document" or "Blanket").