

DOCUMENT RESUME

ED 259 483

EC 180 219

TITLE Barrier Free Design Handbook: Accommodations for the Physically Handicapped.

INSTITUTION Veterans Administration, Washington, DC. Office of Construction.

REPORT NO H-08-13

PUB DATE [85]

NOTE 53p.

AVAILABLE FROM Superintendent of Documents, U.S.; Government Printing Office, Washington, DC 20402.

PUB TYPE Guides - Non-Classroom Use (055)

EDRS PRICE MF01/PC03 Plus Postage.

DESCRIPTORS *Accessibility (for Disabled); *Building Design; *Design Requirements; *Physical Disabilities

ABSTRACT

The handbook sets forth design requirements for construction and renovation of buildings owned, leased, or funded by the Veterans Administration (VA), to permit physically handicapped persons ready access. The book is intended mainly for use by the VA staff and contracted architect/engineer firms involved in developing criteria and designing, constructing, and renovating VA buildings and facilities. Specifications are presented for the following accessible spaces and elements: passenger loading areas, walks, parking areas, curb ramps, ramps, entrances, doors and doorways, floors, corridor handrails, stairs, elevators, platform lifts, toilet rooms, water fountains, public telephones, controls, alarm systems, hazards, carpets, cafeteria and retail store facilities, patient bedrooms, and special consideration areas. A checklist for barrier free design concludes the handbook. (CL)

 * Reproductions supplied by EDRS are the best that can be made *
 * from the original document. *

ED259483



U.S. DEPARTMENT OF EDUCATION
NATIONAL INSTITUTE OF EDUCATION
EDUCATIONAL RESOURCES INFORMATION
CENTER (ERIC)
This document has been reproduced as
received from the person or organization
originating it.
Minor changes have been made to improve
reproduction quality.
Points of view or opinions stated in this docu-
ment do not necessarily represent official NIE
position or policy.

Barrier Free Design Handbook

Accommodations for the Physically Handicapped



H 08 13

Office of Construction

FOREWORD

VA Construction Standard, CD-28, "Accommodations for the Physically Handicapped," requires compliance with this handbook to insure that VA construction and renovation projects incorporate the requisites for making VA facilities accessible to physically handicapped persons.

A checklist for barrier-free design is contained in this handbook to assist the VA construction and facilities managerial staff who are responsible for the elimination of architectural barriers in both new and existing VA facilities.

This handbook will be updated to reflect future revisions to Federal minimum accessibility requirements. All recommendations for changes or improvements should be sent to the Architectural Accessibility Compliance Division (08LA).



W. D. FOTE, Acting Director
Office of Construction

CONTENTS

1.	PURPOSE	1
2.	GENERAL TERMINOLOGY	1
3.	HUMAN DATA	1
4.	ACCESSIBLE SPACES AND ELEMENTS	4
4.1	Passenger Loading Area	4
4.2	Walks	4
4.3	Parking	7
4.4	Curb Ramps	9
4.5	Ramps	11
4.6	Entrances	13
4.7	Doors and Doorways	13
4.8	Floors	18
4.9	Corridor Handrails	19
4.10	Stairs	19
4.11	Elevators	21
4.12	Platform Lifts	28
4.13	Toilet Rooms	28
4.14	Water Fountains	31
4.15	Public Telephones	31
4.16	Controls	33
4.17	Alarm Systems	33
4.18	Hazards	33
4.19	Carpets	35
4.20	Cafeteria and Retail Store Facilities	35
4.21	Patient Bedrooms	35
4.22	Special Consideration Areas	35

FIGURES

Fig. 1	Dimension Data	2
Fig. 2	Reach Data	3
Fig. 3	Passenger Loading Zone	5
Fig. 4	Gratings	6
Fig. 5	Accessible Parking	8
Fig. 6	Curb Ramps at Crossings	10
Fig. 7	Ramps With Landings	12
Fig. 8	Maneuvering Clearance for Doors	15
Fig. 9	Accessible Route Clearances	16
Fig. 10	Doors in Series	17
Fig. 11	Stairs and Nosings	20
Fig. 12	Stair Handrails and Extensions	22
Fig. 13	Overhead Clearance	23
Fig. 14	Time and Travel Distance	25

Fig. 15 Elevator Auxiliary Control Panel 26
Fig. 16 Toilet Stalls 30
Fig. 17 Public Telephones 32
Fig. 18 Projecting Objects 34
Fig. 19 Wheelchair Viewing Areas 37

CHECKLIST FOR BARRIER FREE DESIGN 38

BARRIER FREE DESIGN HANDBOOK
ACCOMMODATIONS FOR THE PHYSICALLY
HANDICAPPED

1. PURPOSE

This handbook sets forth the design requirements for the construction and renovation of buildings and facilities, owned, leased or funded by the Veterans Administration (VA), so that physically handicapped persons will have ready access and use of such buildings and facilities. Since the handbook incorporates VA's more stringent requirements, it is intended mainly for the use of the VA staff and contracted Architect/Engineer firms involved in developing criteria, designing, constructing and renovating VA buildings and facilities. The handbook is not to be interpreted as a Federal accessibility standard.

The Architectural Barriers Act of 1968, Public Law 90-480, "insures that certain buildings financed with Federal funds are so designed and constructed as to be accessible to the physically handicapped." To comply with Public Law 90-480, the VA is required to meet the minimum accessibility standards employed by the General Services Administration (GSA). Under the Federal Property Management Regulations, Chapter 101, Subpart 101-19.6, "Accommodations for the Physically Handicapped," GSA currently prescribes the "Uniform Federal Accessibility Standards." This Federal Standard, as well as the Architectural and Transportation Barriers Compliance Board "Minimum Guidelines and Requirements for Accessible Design" and the American National Standard, ANSI A117.1-1980 "Specifications for Making Buildings and Facilities Accessible to and Usable by Physically Handicapped People" were consulted in the preparation of this handbook.

2. GENERAL TERMINOLOGY

In Section 4, "Accessible Spaces and Elements," "may" denotes an option or alternative. All other language used in Section 4 of this handbook is to be interpreted as mandatory to meet accessibility requirements in VA buildings and facilities. Where "accessibility" is used, it means access to, and use by, all persons with a physical disability.

3. HUMAN DATA

Figures 1 and 2 relate to anthropometrics and spatial, reach, sensory, and manipulative consideration affecting the physically impaired.

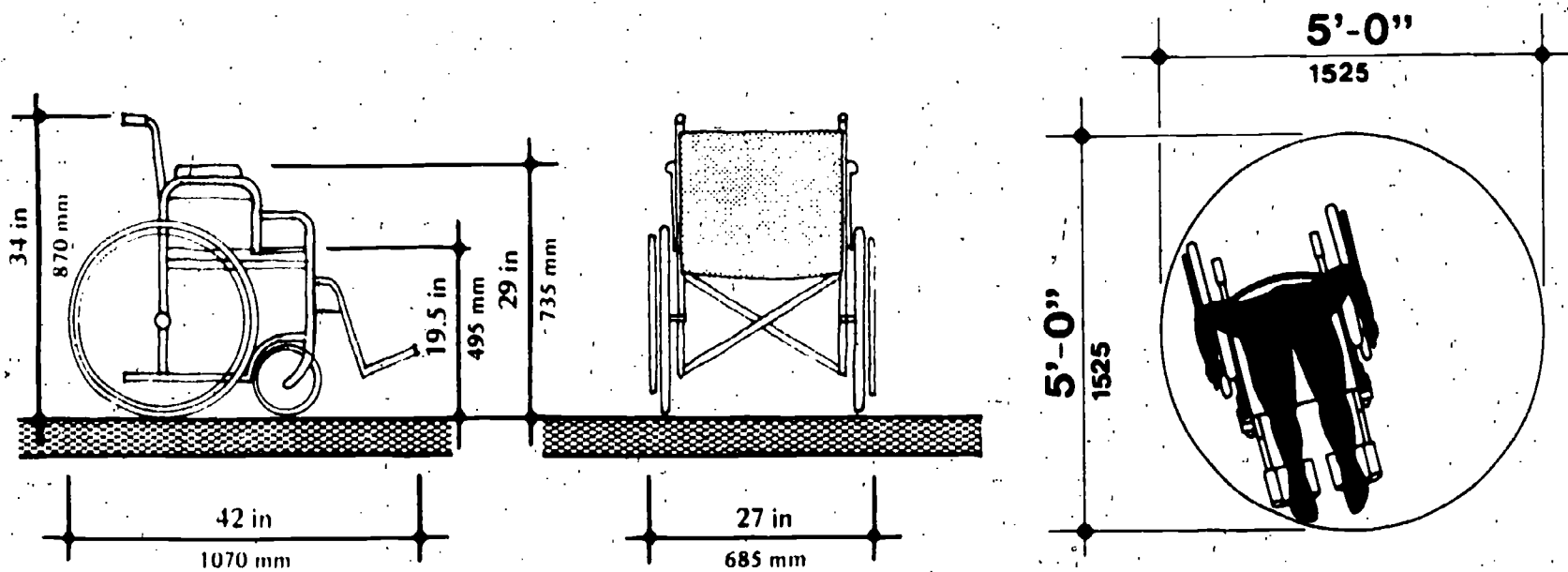

Wheelchair

Side View

Rear View

Turning Diameter

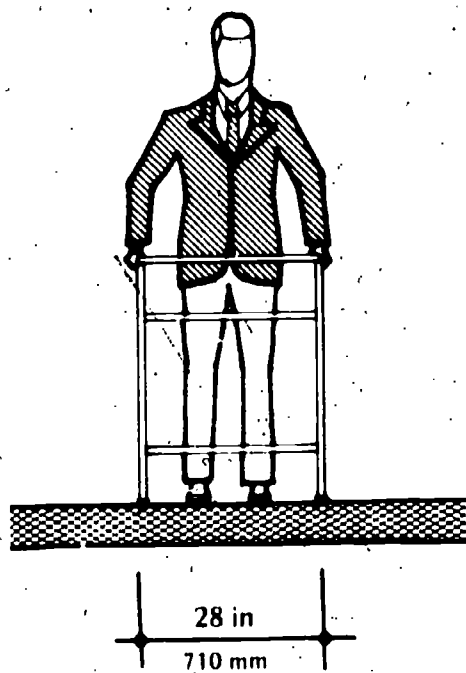

Man with Walking Aid

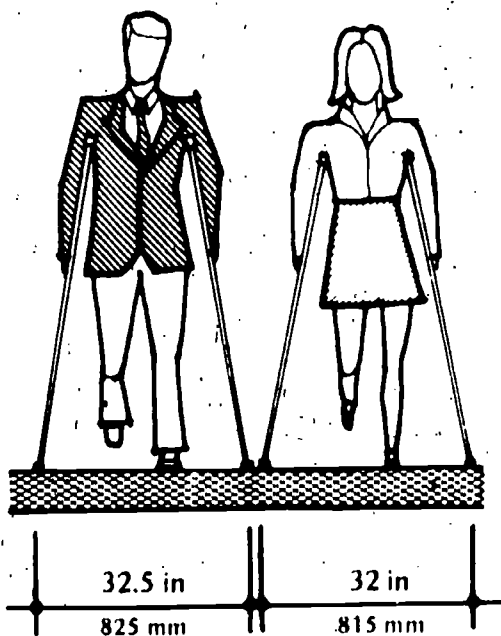

Man and Woman on Crutches

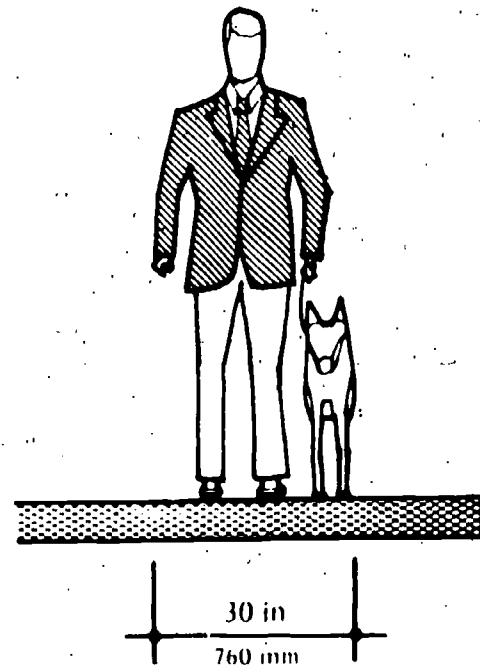

Visually Impaired Man with Guide Dog

Dimension Data

Figure 1

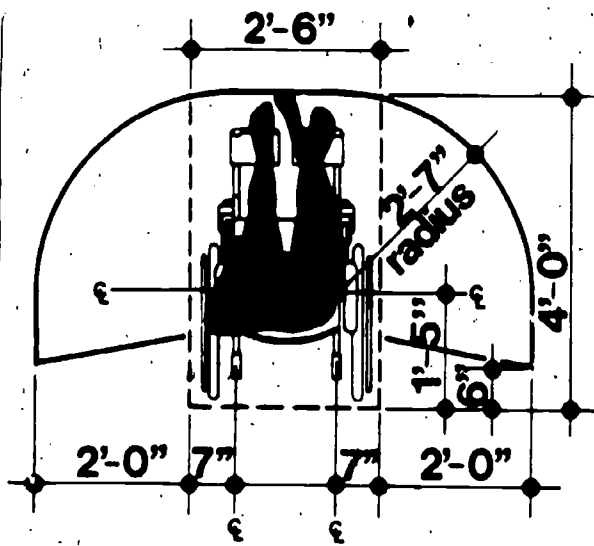

reach range

objects 4'-0" high max.

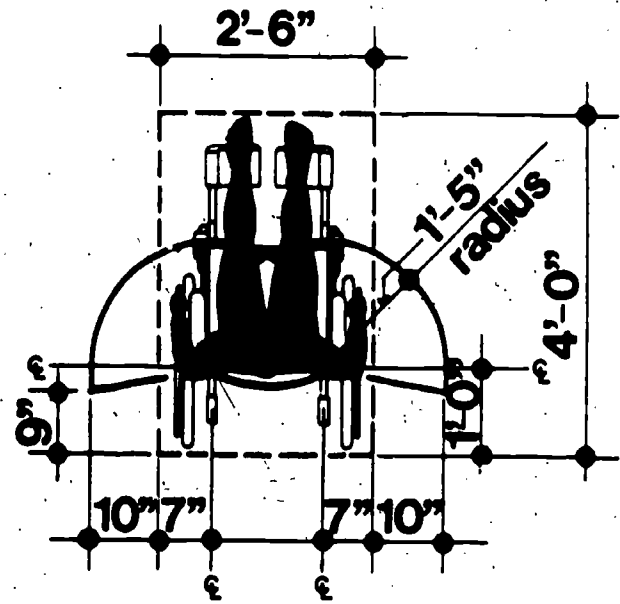

reach range

objects 4'-6" high max.

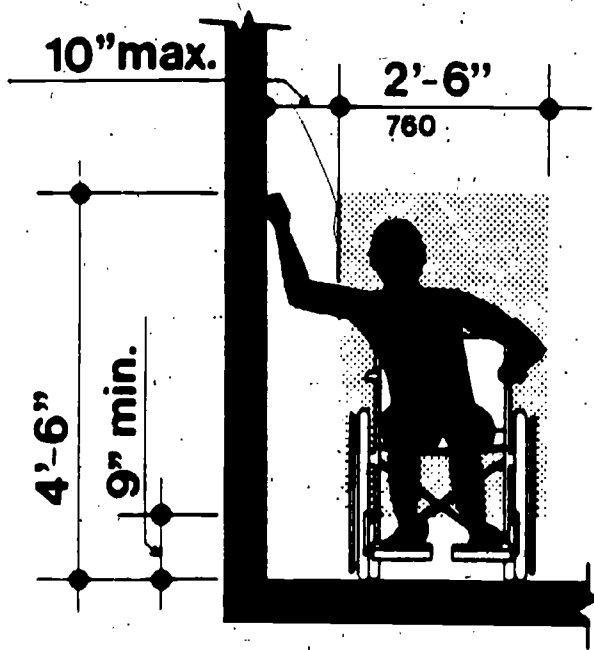

side reach

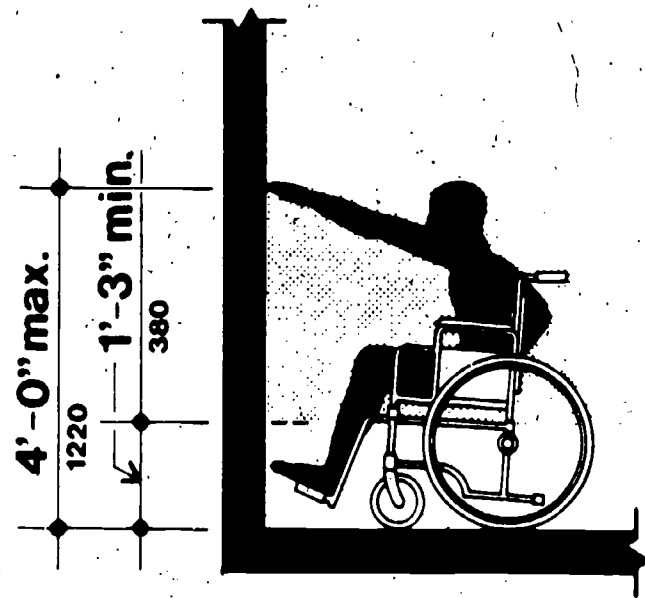

forward reach

Reach Data

Figure 2

4. ACCESSIBLE SPACES AND ELEMENTS

- 4.1 Passenger Loading Areas.** Locate passenger loading area in a safe place, on or off the street, and as close as possible to an accessible entrance. Zone the area. Provide an access aisle 5'-0" wide by 20'0" long, parallel and level with the vehicle pull-up space. (See Fig. 3) Install a curb ramp if there is a curb between the access aisle and accessible route. At health facilities provide a canopy or roof overhang to protect the passenger loading area from the weather.
- 4.2 Walks.** Provide at least one accessible walk from accessible parking spaces, passenger loading areas, public streets and sidewalks, and public transportation stops, where provided, into each accessible entrance of the building to be served. Provide at least one accessible walk between buildings on a common site.
- 4.2.1** Accessible walks shall be free of steps and abrupt changes of level. The clear width shall be at least 5'-0". A running slope shall not exceed 1:33. A walk with a running slope exceeding 1:33 shall be treated as a ramp, but walk width shall apply. A cross slope shall not exceed 1:96.
- 4.2.2** Provide level rest zones for accessible walks which have running slopes between 1:50 and 1:33. The rest zones shall be spaced at no more than 200 feet apart and measure a minimum of 5'-0" long by the full width of the walk.
- 4.2.3** A change in level in an accessible walk between 1/4" and 1/2" shall be beveled with a slope no greater than 1:2. A change in level exceeding 1/2" shall be treated as a ramp.
- 4.2.4** The surface of accessible walks shall be stable, firm and of sufficient texture to resist slippage.
- 4.2.5** Where gratings are unavoidable in accessible walks, the spaces of the grating shall not be greater than 1/2" in the direction of travel. Gratings having elongated openings shall be placed so that the long dimension is perpendicular to the dominant direction of travel. (See Fig. 4)
- 4.2.6** Where doors open onto an accessible walk, provide a clear and level platform, measuring a minimum of 6'-0" x 6'-0".

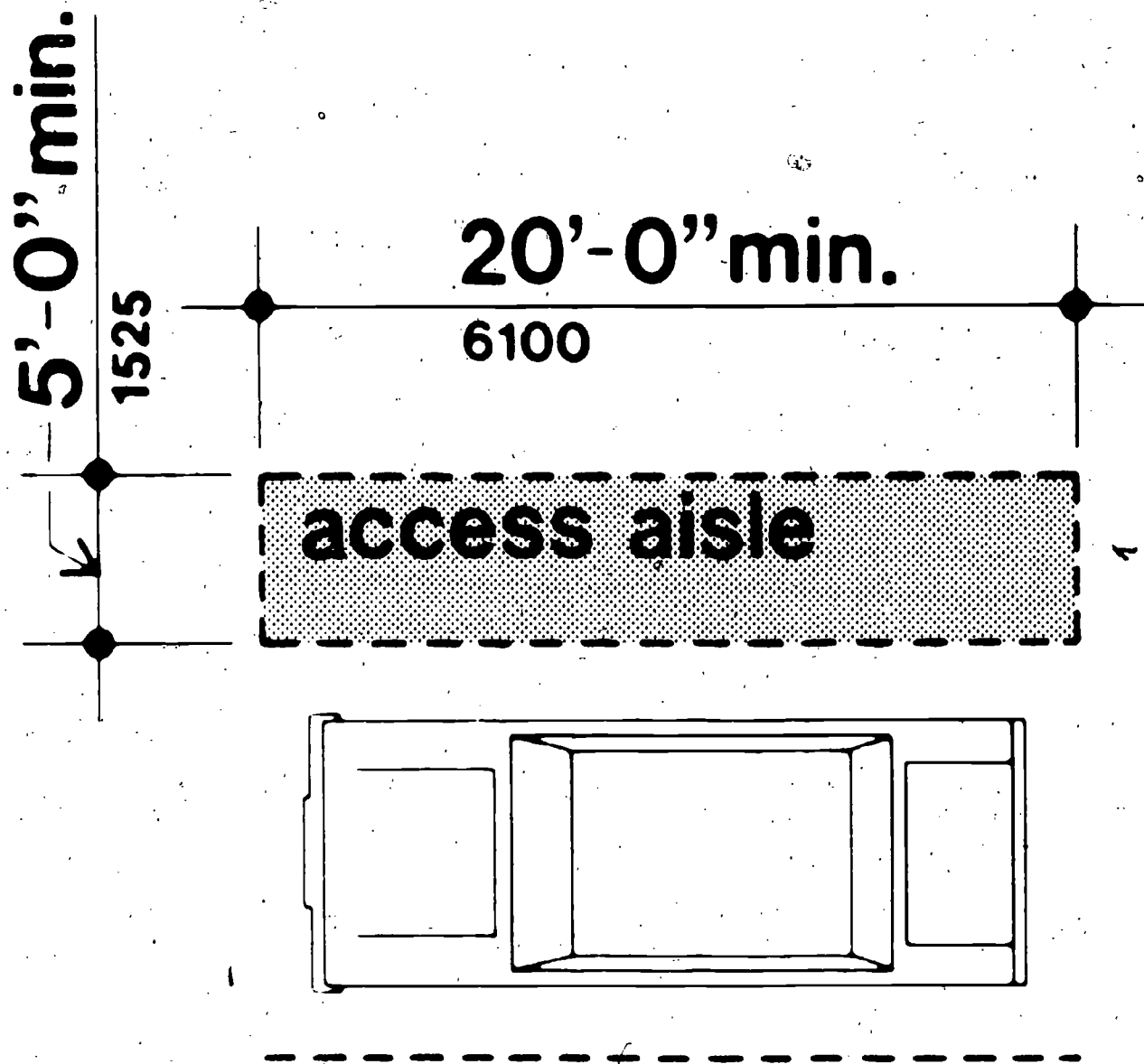

Passenger Loading Zone

Figure 3

long dimension
perpendicular to
route of travel

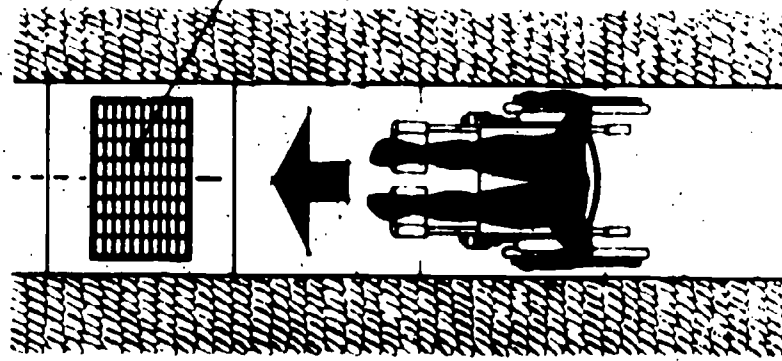

← predominant direction
of traffic →

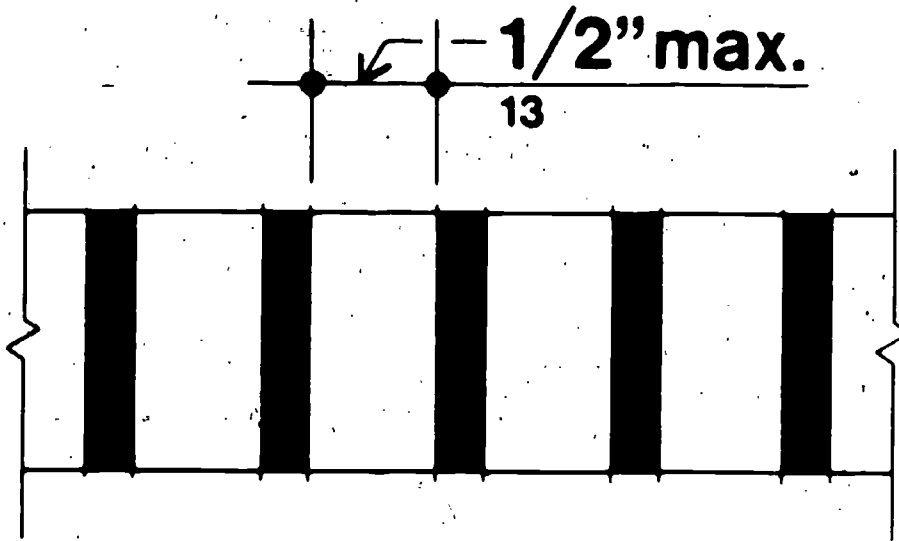

**section:
grating**

Gratings

Figure 4 11

4.2.6.1 The exterior platform shall extend a minimum of 1'-6" beyond the latch side and a minimum of 6" beyond the hinge side of single doors, and 6" beyond both sides of double-leaf doorways.

4.3 **Parking.** Where parking is provided, allow the minimum specified in the following table:

Total Parking Spaces	Required Minimum Number of Accessible Spaces
1 to 25	1
26 to 50	2
51 to 75	3
76 to 100	4
101 to 150	5
151 to 200	6
201 to 300	7
301 to 400	8
401 to 500	9
501 to 1000	*
1001 and over	**

* 2 percent of total

** 20 plus 1 for each 100 spaces over 1000

EXCEPTIONS:

All outpatient facilities: 10 percent of the total number of parking spaces provided.

Spinal Cord Injury (SCI) facilities: A dedicated lot of 1.5 parking spaces per SCI bed.

4.3.1 Locate accessible parking spaces as close as possible to accessible entrances and to an accessible walk serving these entrances.

4.3.2 The width of accessible parking spaces shall be at least 8'-0".

4.3.3 Provide access aisles, measuring at least 5'-0" wide, on both sides of each parking space. Access aisles shall not have a slope greater than 1:50 and shall blend with the adjoining walk. (See Fig. 5) Mark the access aisles to prevent vehicles parking within their limits. Use a surface for the access aisles which is stable, firm and of sufficient texture or abrasion to resist slippage. Brushed concrete and vinyl sheet flooring with raised mineral aggregate particles are acceptable designs.

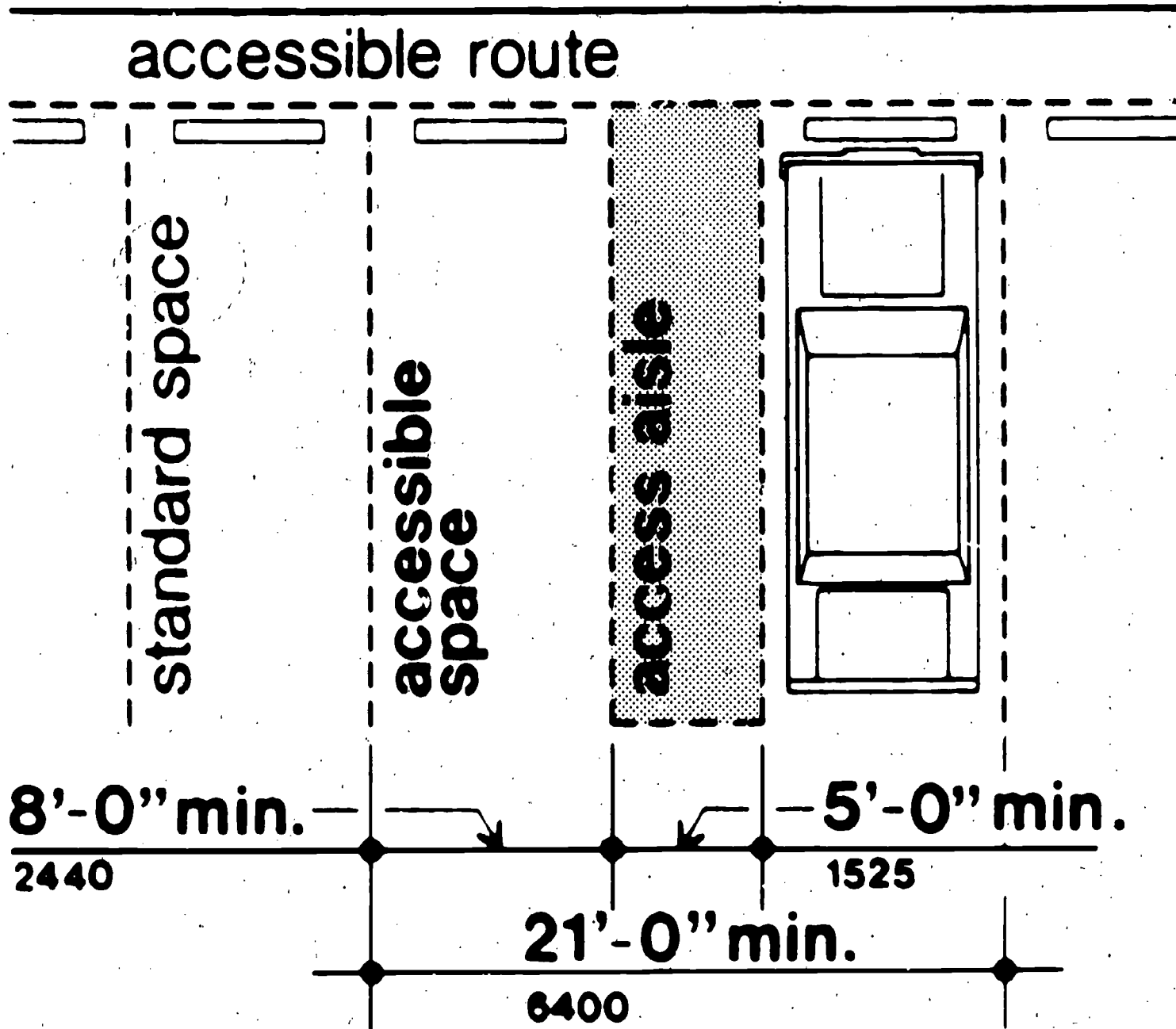

NOTE: Accessible spaces for vans must be 11'-0" wide, have access aisles, and be designated for vans only.

Accessible Parking

Figure 5

- 4.3.4 Maintain the minimum clear width of adjoining walkways, using wheelstops, railings, bollards or other devices as required.
- 4.3.5 Identify accessible parking spaces as reserved for the handicapped through the display of the "International Symbol of Accessibility." In large lots (more than 200 spaces), provide routing signage at the entrance to the lot and other locations to direct handicapped drivers to the accessible parking spaces. Install the signage according to the criteria in the VA manual, M-00-2, Signage System Standards Manual, as prescribed by VA Construction Standard 15-2.
- 4.3.6 Where parking is provided, the following accessible spaces should be included for vans adapted for disabled drivers:
- Regular areas -- 1% of total parking spaces
 - Outpatient facilities -- 3% of total spaces provided
- 4.3.7 The size of accessible parking spaces for vans shall be at least 16'-0" wide and 21'-0" long. (If access aisles are already in place, the width may be reduced to 11'-0".)
- 4.3.8 Identify accessible van parking space appropriately. See Fig. 5.
- 4.4 Curb Ramps.** Provide curb ramps wherever a walk crosses a curb. Locate curb ramps to prevent obstruction by parked vehicles. At marked street crossings, locate curb ramps totally within the markings. At diagonal or corner type curb ramps, provide a minimum clear space of 4'-0" at the bottom of the ramp. (See Fig. 6)
- 4.4.1 Curb ramps shall have a minimum width of 3'-0", exclusive of flared sides.
- 4.4.2 Curb ramps shall have a maximum slope of 1:12.
- 4.4.3 The transition from curb ramps to walks, gutters or streets shall be flush and free of abrupt change.
- 4.4.4 Where pedestrian traffic is likely to walk across the curb ramps, the ramps shall have flared sides with a maximum slope of 1:10. Where pedestrians would not normally walk across the ramp, curb ramps with returned curbs may be used.

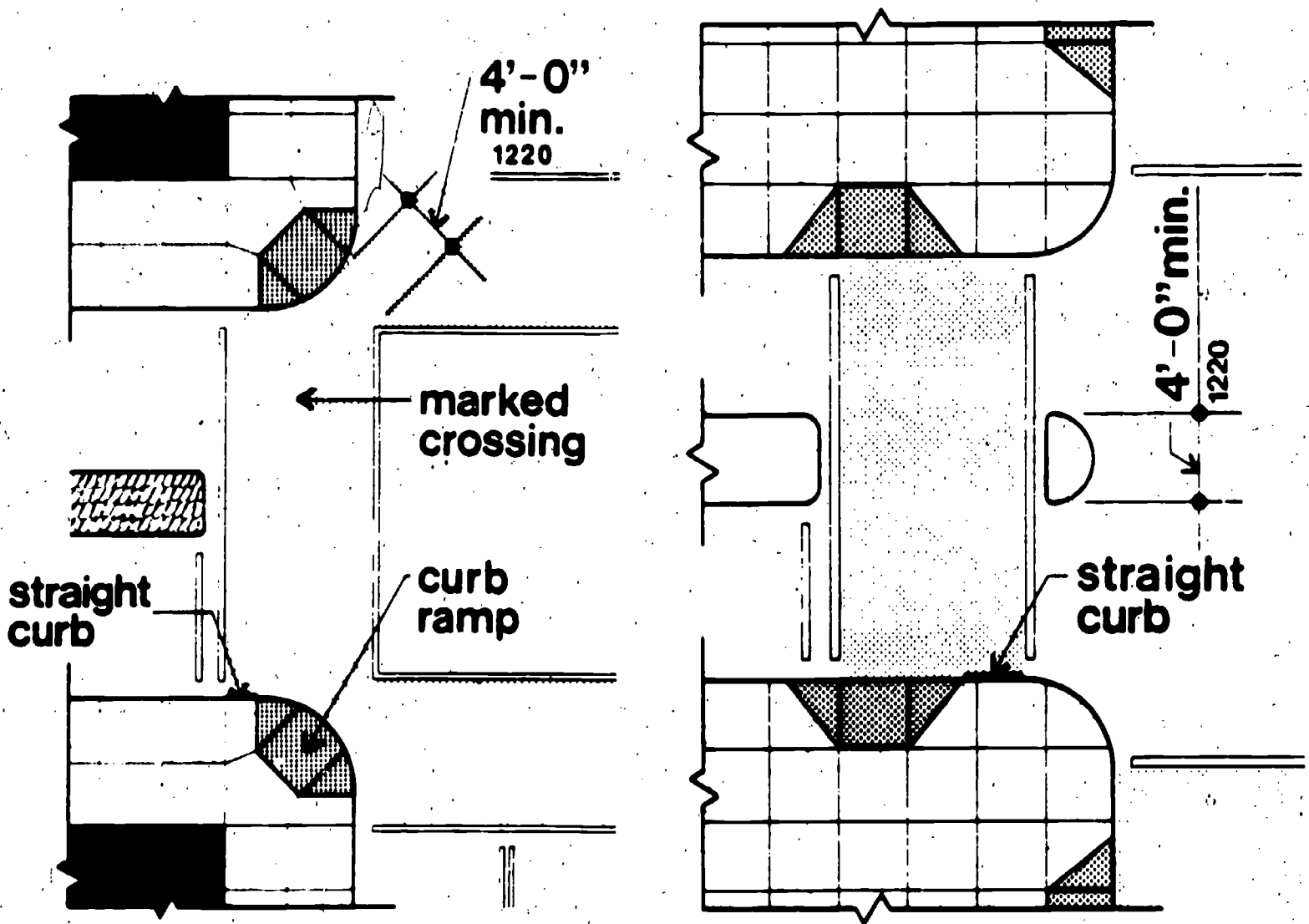

Curb Ramps at Crossings

Figure 6

4.4.5 Use built-up curb ramps only when no alternative is available. Locate built-up curb ramps so that they do not project into vehicular lanes. The flared sides of the ramps shall have a slope no greater than 1:10.

4.4.6 The surface of curb ramps shall be stable, firm and of sufficient texture or abrasion to resist slippage. Brushed concrete and vinyl sheet floor covering with raised mineral aggregate particles are acceptable designs.

4.5 **RAMPS.** Ramps shall have a maximum slope of 1:20. Cross slopes of ramps shall be no greater than 1:96. The width of ramps shall not be less than 4'-0". Ramps with slopes from 1:33 to 1:24 shall not exceed 40'-0" in length. Ramps with slopes from 1:25 to 1:20 shall not exceed 35'-0" in length. Inclined surfaces with a slope exceeding 1:20 or a rise exceeding 20" shall have a platform lift or elevator for vertical access.

4.5.1 Provide level landings at the top, bottom and change of direction of each ramp run and at 35' or 40' intervals on straight run ramps depending on the slope. Each such landing shall be at least as wide as the ramp leading to it and shall measure no less than 5'-0" in length. Where ramps change direction at landings, the minimum size of the landings shall be 5'-0" x 5'-0". (See Fig. 7)

4.5.2 Where doors open onto a ramp, provide a clear and level platform, measuring a minimum of 6'-0" x 6'-0". The exterior platform shall extend a minimum of 1'-6" beyond the latch side and a minimum of 6" beyond the hinge side of single doors, and 6" beyond both sides of double-leaf doorways.

4.5.3 Provide handrails on both sides of a ramp where the ramp has a rise greater than 6" or a horizontal run greater than 6'-0". Provide a continuous inside handrail on switchback or dogleg ramps. Where handrails are not continuous, they shall extend a minimum of 1'-0" beyond the beginning and end of the ramp segment, parallel with the floor or ground surface.

4.5.3.1 Install handrails at a height of 2'-8", measured from the ramp surface to the top of the handrail. The nominal diameter or cross section of the gripping surface of a handrail shall be 1-1/2". The edges of noncircular handrail sections shall have a minimum radius of 1/8". Handrail sections shall have no sharp edges and shall permit the continuous sliding of hands. Ends of handrails shall be rounded and returned smoothly to wall, floor or post.

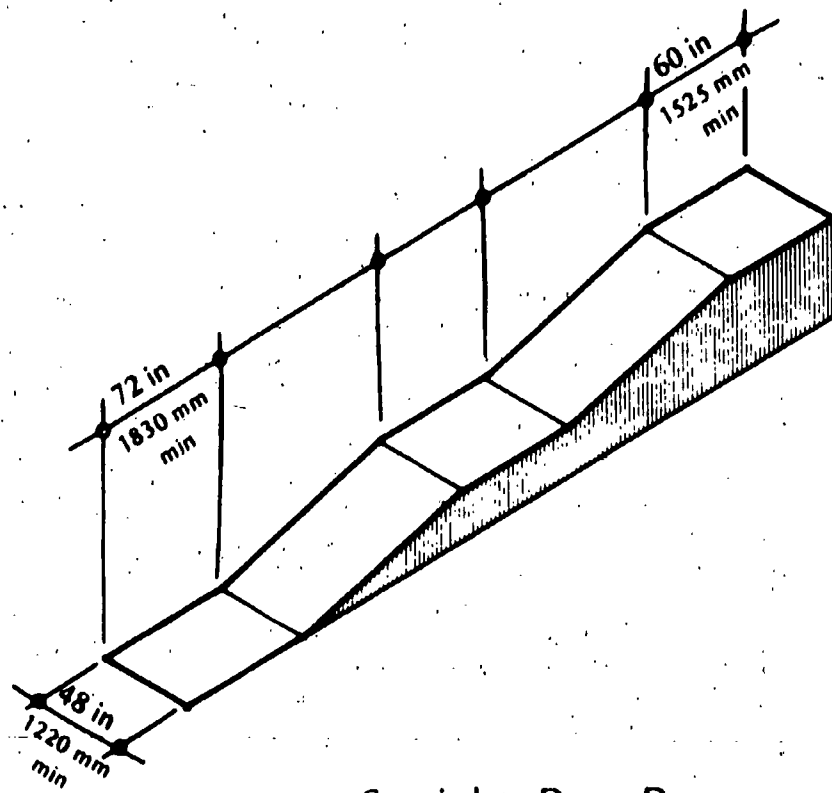

Straight Run Ramp

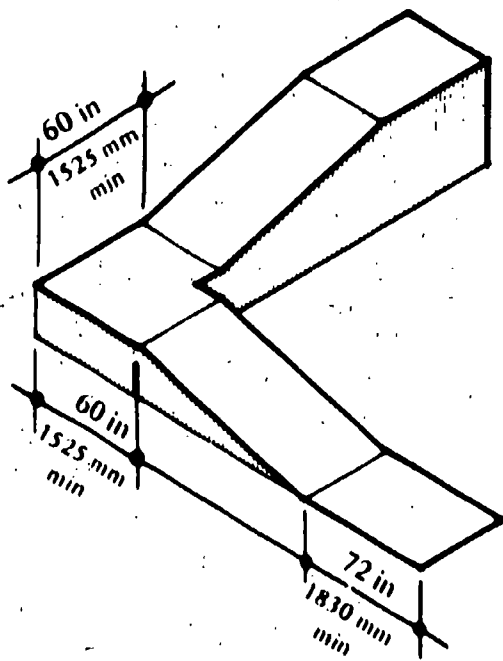

Ramp With 90-Degree Turn

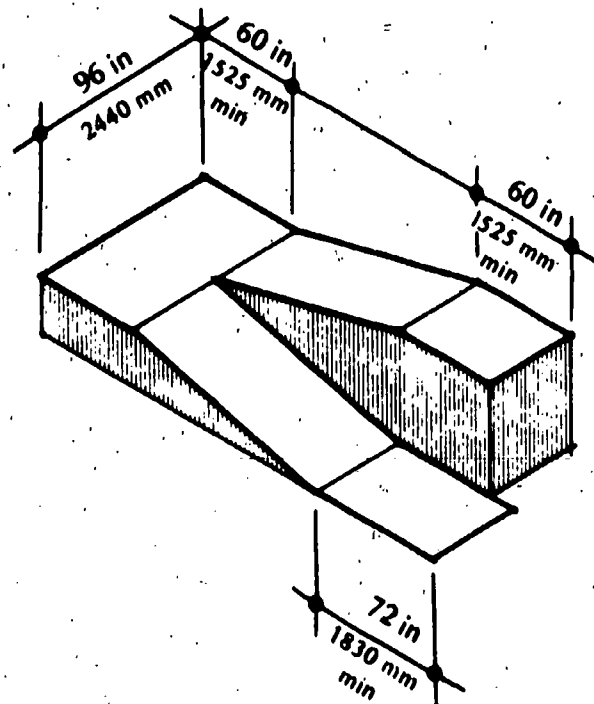

Switch-Back Ramp

Ramps with Landings

Figure 7

- 4.5.3.2 Where the handrail is mounted adjacent to a wall, the space between the wall and the handrail shall be 1-1/2". Wall surfaces behind handrails shall be smooth and free of sharp protusions.
- 4.5.3.3. The anchoring components of handrails shall be capable of supporting a 250-lb force applied in any direction at any point along the handrail.
- 4.5.3.4 Where ramps and landings have a drop off, provide curbs, walls, railings or projecting surfaces that prevent people from slipping off the ramp. Ramp curb shall be at least 4" high by 4" wide.
- 4.5.3.5 Ramp and landing surfaces shall be stable, firm and of sufficient texture or abrasion to resist slippage. Brushed concrete and vinyl sheet floor covering with raised mineral aggregate particles are acceptable designs.
- 4.6 Entrances.** All main, outpatient and other frequently used entrances shall be accessible. Accessible entrances shall be connected by accessible walks to accessible parking, passenger loading zones, public streets and sidewalks and public transportation stops. Accessible entrances shall also be connected to all accessible elements, e.g., elevators, telephones or ramps, and spaces throughout the building by means of accessible paths of travel having a minimum clear width of 3'-0".
- 4.6.1 Identify accessible entrances through the display of the "International Symbol of Accessibility" and prominently placed routing signs.
- 4.7 Doors and Doorways.** All doors to accessible entrances, spaces, and elements and along accessible routes shall comply with this section. Revolving doors or turnstiles shall not be the only means of passage at an accessible entrance or along an accessible route. An accessible door shall be provided adjacent to the turnstile or revolving door.
- 4.7.1 Where doorways have double leaves, then at least one leaf shall be active and shall comply with the requirements in this section.
- 4.7.2 Doorways shall have a minimum clear width of 2'-10", with the door opened 90 degrees and measured from the face of the door to the face of the door stop.

- 4.7.3 For doors that are not automatic and that open onto walkways and ramps provide exterior platforms and clear interior floor spaces which meet the requirements of this section.
- 4.7.3.1 The exterior platform shall be clear and level. It shall measure a minimum of 6'-0" x 6'-0". The platform shall extend a minimum of 1'-6" beyond the latch side and a minimum of 6" beyond the hinge side of single doors, and 6" beyond both sides of double-leaf doorways. (See Fig. 8)
- 4.7.3.2 The clear interior floor space shall be level, have a depth of a minimum of 4'-0" and extend a minimum of 1'-6" beyond the latch side and a minimum of 6" beyond the hinge side of the door. (See Fig. 8)
- 4.7.4 Where manual doors open onto corridors and other pedestrian paths of travel, the floor areas shall be clear and level. They shall extend at least 5'-0" from the pull side of the door and a minimum of 4'-0" from the push side of the door. The clear floor spaces shall extend a minimum of 1'-6" beyond the latch side on the pull side of the door; a minimum of 6" beyond the latch side of the push side of the door and a minimum of 6" beyond the hinge side on both the pull and push sides of the door. (See Fig. 9)
- 4.7.5 **Exception.** Hospital patient bedroom doors, which are a minimum of 3'-10" wide, shall be exempt from the 1'-6" latch side requirement.
- 4.7.6 The minimum space between manual doors in a series (vestibule doors) in a straight line shall be 4'-0" ~~plus the width of any door swinging into the space.~~ The minimum space for doors in a series at right angles to each other shall be as shown in Fig. 10. Both manual doors in series shall swing in the same direction.
- 4.7.7 The maximum force for pushing or pulling open a door shall be:
- a. Fire doors: Maximum opening force allowable by the appropriate administrative authority.
 - b. Other doors:
 - i. Exterior hinged doors: RESERVED
 - ii. Interior hinged doors: 5 lbf
 - iii. Sliding or folding doors: 5 lbf

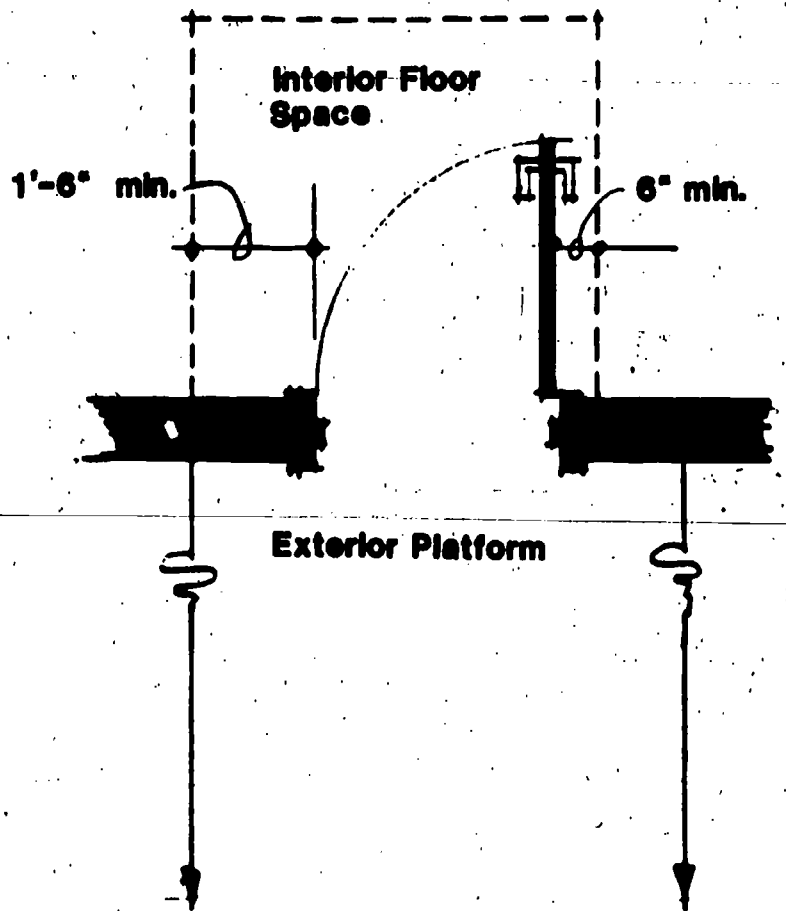
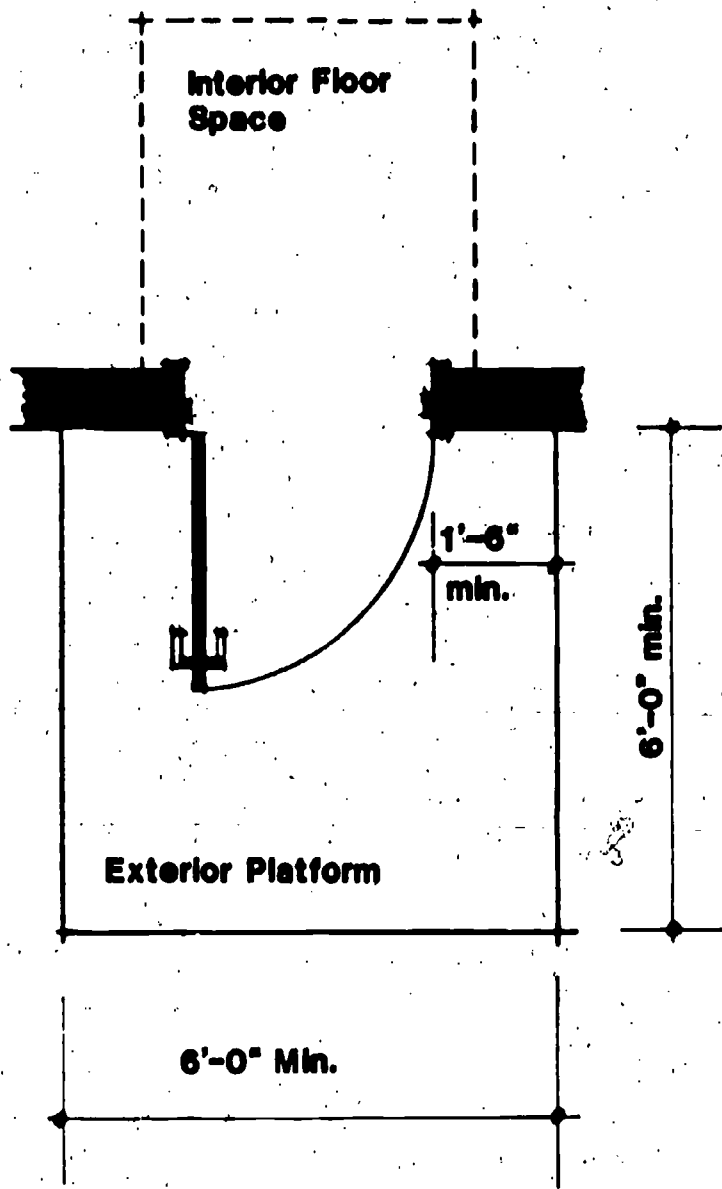

Maneuvering Clearance for Doors

Figure 8

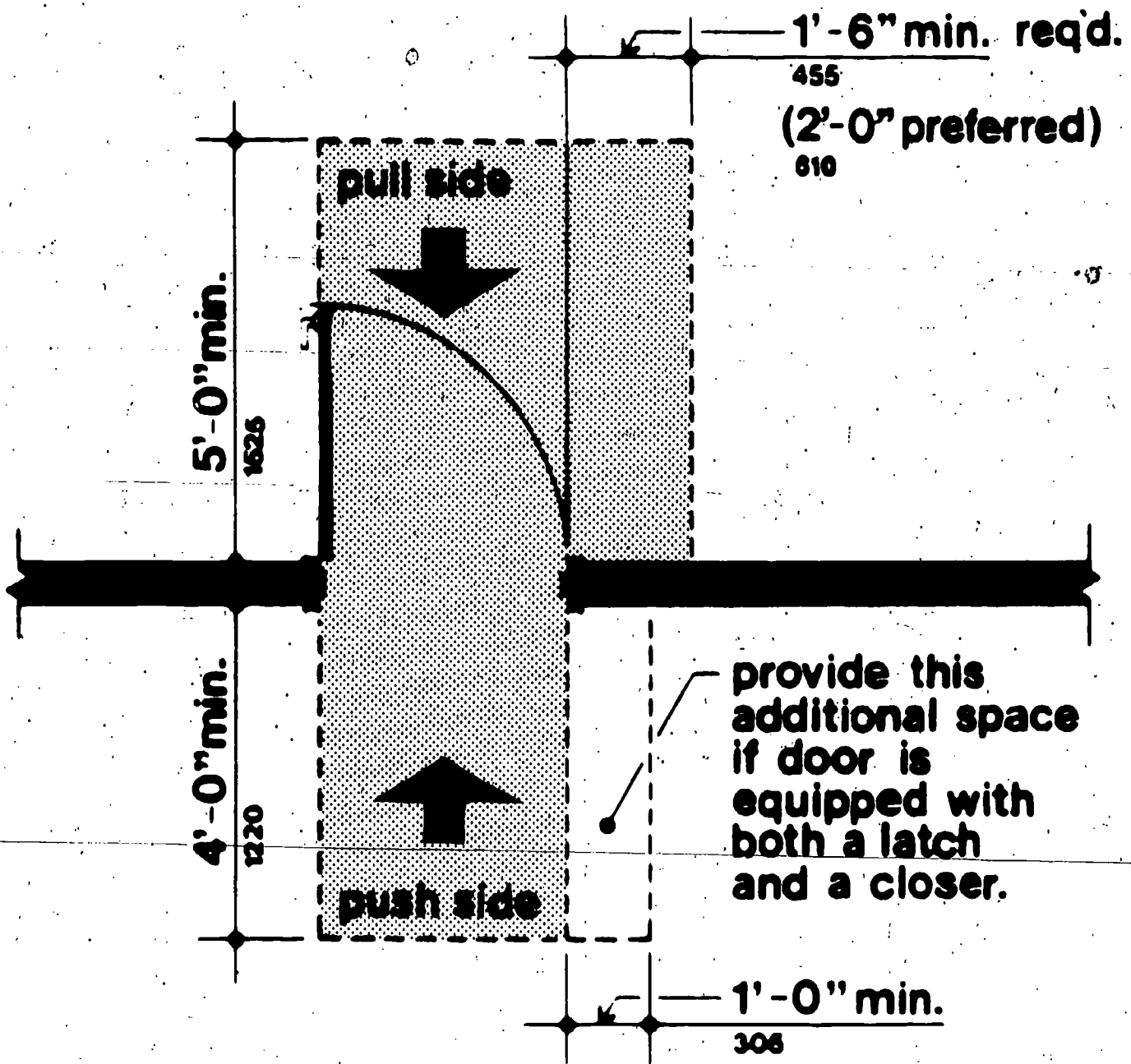

Accessible Route Clearances

Figure 9

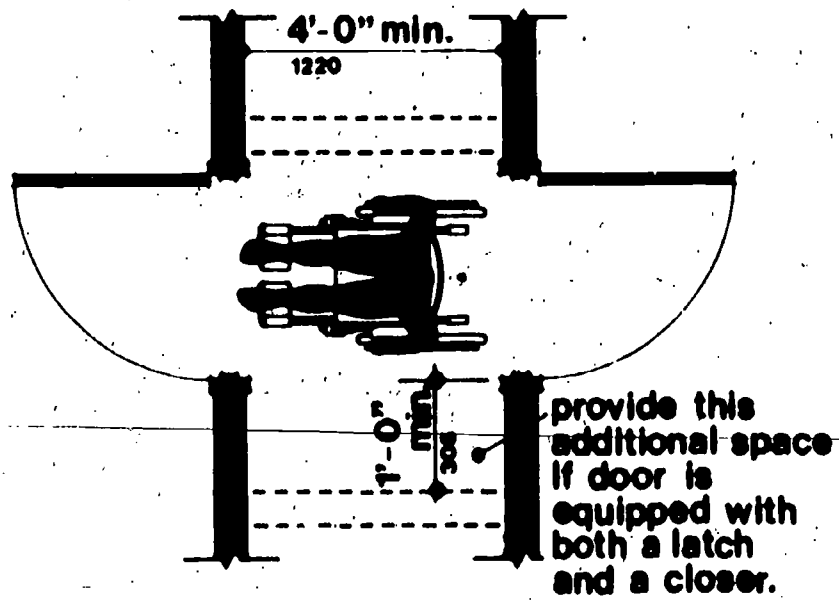
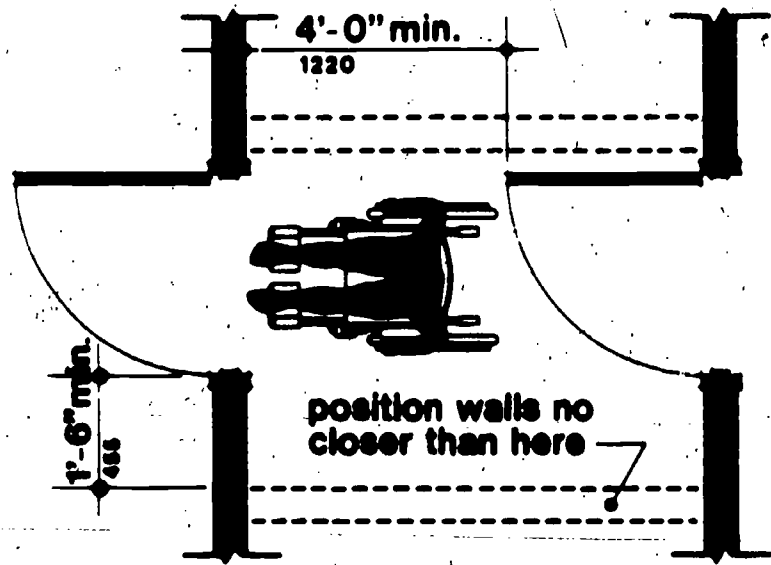

Doors in Series

Figure 10

- 4.7.8 Thresholds at accessible entrances and throughout the facility shall not project above the finished floor. Where a change in level is caused by transition between different types of flooring materials, it shall not exceed 1/2" in height and must be beveled with a slope no greater than 1:2.
- 4.7.9 Handles, pulls, latches, locks and other operating devices on doors to accessible spaces shall have a shape that is easy to grasp and operate with one hand and does not require tight grasping, pinching or twisting of the wrist to operate. Lever-operated mechanisms, push-type mechanisms and U-shaped handles are acceptable designs. When sliding doors are fully open, operating hardware shall be exposed and usable from both sides.
- 4.7.10 Doors leading into hazardous areas that might prove dangerous to a blind person shall be made quickly identifiable to the touch by knurling, roughening or applying an abrasive coating to the surface of the door handle, knob, pull or other operating hardware. Tactile warning indicators shall not be provided for emergency exit doors.
- 4.7.11 In order to prevent the footrest on wheelchairs from catching on door stiles, the bottom surface of all doors, except automatic doors, shall be flush up to a minimum height of 1'-0", measured from the finished floor, or shall be equipped with a kickplate or bottom rail of the same dimension.
- 4.7.12 Where automatic pedestrian doors are provided, they shall not open to back check in less than 3 seconds and shall not require more than 15 lbs. to stop door movement. For additional information refer to the "American National Standard for Power-Operated Doors," ANSI A156.10.
- 4.7.13 Power assisted doors shall comply with subsection 4.7.7 for maximum opening force.
- 4.8 **Floors.** Changes in level of floor surfaces up to 1/4" may be vertical and without edge treatment. Changes in level between 1/4" and 1/2" shall be beveled with a slope no greater than 1:2. Changes in level greater than 1/2" shall be treated as a ramp.
- 4.8.1 **Exception.** All floors on which SCI services are provided shall be free of changes of level.

4.8.2

Floor surfaces shall be firm, stable and nonslip. Vinyl sheet flooring with raised mineral aggregate particles is an acceptable design.

4.9

Corridor Handrails. Where corridor handrails are required, they shall be mounted at a height of 3'-0", measured from the finished floor to the top of the handrail.

4.9.1

The nominal diameter or cross section of the gripping surface of a handrail shall be 1-1/2". The edges of noncircular handrail sections shall be a minimum radius of 1/8". Handrail sections shall have no sharp edges and shall permit the continuous sliding of hands. Ends of handrails shall be rounded and returned smoothly to wall, floor or post.

4.9.2

The space between the wall and corridor handrail shall be 1-1/2". Wall surfaces behind handrails shall be smooth and free of sharp protrusions.

4.9.3

The anchoring components of corridor handrails shall be capable of supporting a 250-lb force applied in any direction at any point along the handrail.

4.10

Stairs. Interior and exterior stairs shall meet the requirements of this section.

4.10.1

Stairs shall be at least 3'-8" wide.

4.10.2

All steps on a single flight of stairs shall meet these requirements:

a. Steps shall have a uniform tread width and uniform riser height.

b. The minimum width of treads shall be 11", measured from riser to riser. Treads shall have a slip-resistant surface.

c. The maximum height of risers shall be 7". Open risers are not permitted.

4.10.3

Square or abrupt nosings are not permitted. Acceptable nosing designs are shown in Fig. 11. The radius curvature at the leading edge of the tread shall be no greater than 1/2". The nosing projection shall be no greater than 1'-0".

4.10.4

Provide handrails at both sides of all stairs. The handrails shall comply with the requirements of this subsection.

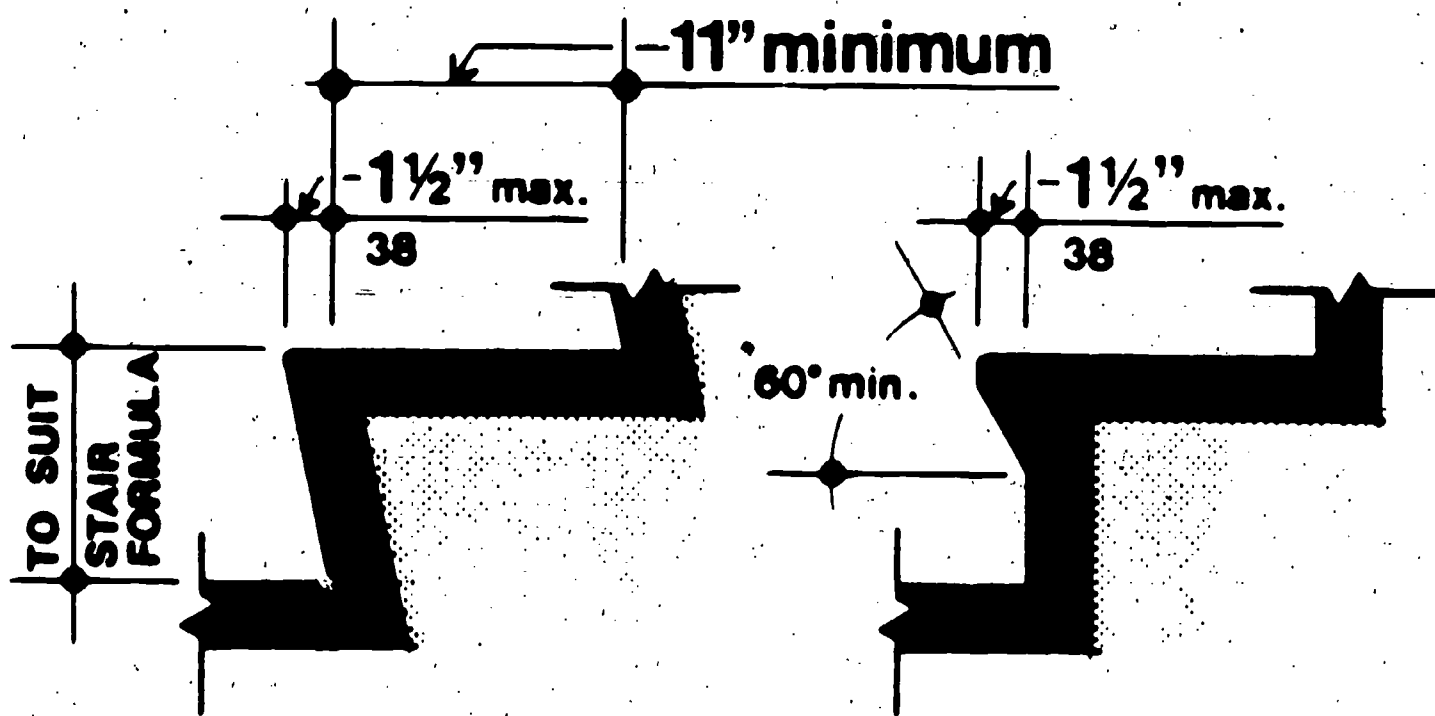

Stairs and Nosings

Figure 11

- 4.10.4.1 At stair landings, extend handrails a minimum of 1'-11" on one side beyond the top riser and 1'-11" on one side beyond the bottom riser. The extensions shall be parallel to the floor. (See Fig. 12)
- 4.10.4.2 Where the path of stair travel changes directions at landings, the inside handrail shall be continuous. (See Fig. 12)
- 4.10.4.3 Stair handrails shall be mounted at a height of 2'-8", measured from the tread nosing to the top of the handrail. (See Fig. 12)
- 4.10.4.4 The nominal diameter horizontal section of the gripping surface of the stair handrail shall be 1-1/2". The edges of noncircular sections of stair handrails shall have a minimum radius of 1/8". Where the handrail is mounted adjacent to a wall, the clear space between the wall and the handrail shall be 1-1/2".
- 4.10.4.5 The anchoring components of stair handrails shall be capable of supporting a 250-lb force applied in any direction along the handrail.
- 4.10.4.6 Stair handrail sections shall have no sharp edges and shall permit the continuous sliding of hands. Wall surfaces behind handrails shall be smooth and free of sharp protrusions. Ends of handrails shall be rounded and returned smoothly to wall, floor or post.
- 4.10.5 A protective barrier or warning signal shall be provided wherever an accessible path or space under a stairway has a headroom clearance less than 6'-8". (See Fig. 13)

4.11 Elevators. All levels of a multi-story building or facility used by occupants or the general public shall be served by an elevator, platform lift (complying with section 4.12, "Platform Lifts") or a ramp (complying with Section 4.5, "Ramps"). Elevators shall conform to ANSI A17.1, "Safety Codes for Elevators, Dumbwaiters, Escalators, and Moving Stairs," and the accessibility requirements specified in this section.

- 4.11.1 The elevator shall be automatic and provided with a self-leveling feature that will automatically bring the car to the floor landings within a tolerance of plus or minus 1/2" under normal loading and unloading conditions. This self-leveling shall, within its zone, be entirely automatic and independent of the operating device and shall correct for overtravel and undertravel. The car shall also be maintained approximately level with the landing regardless of load.

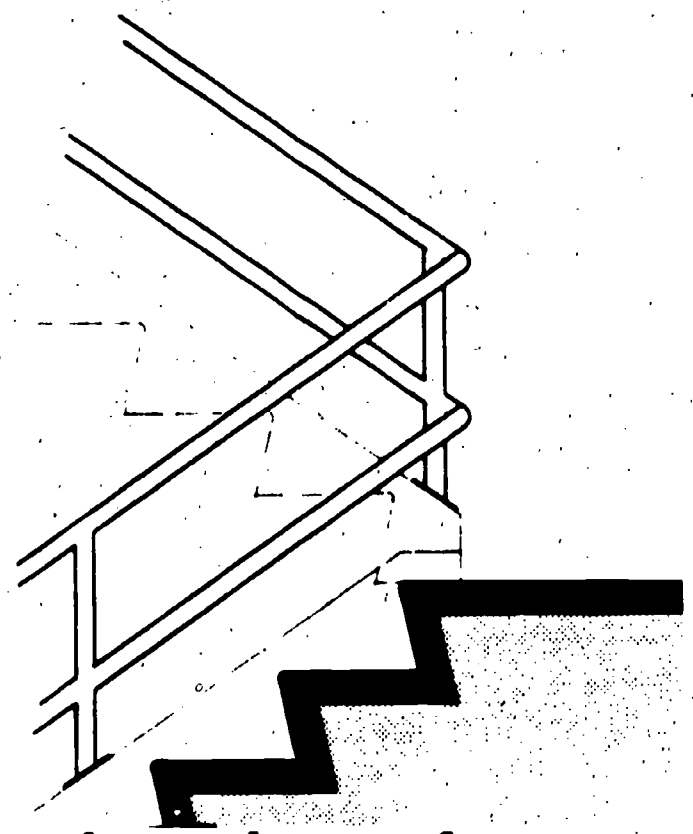
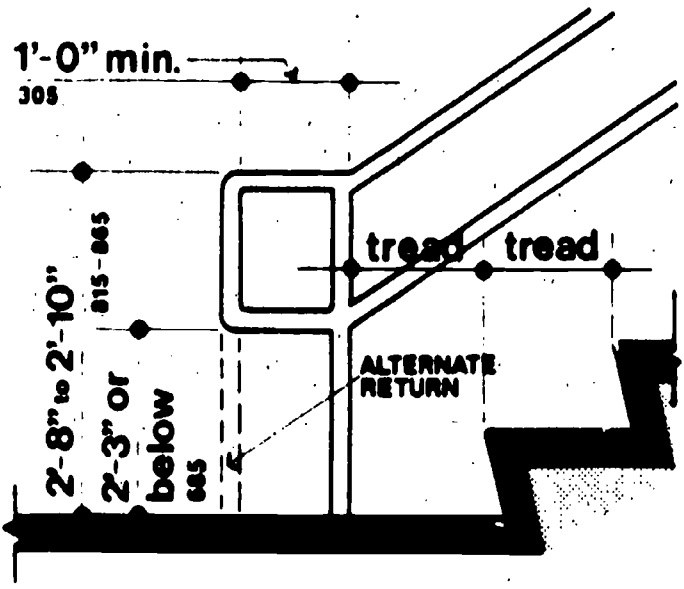
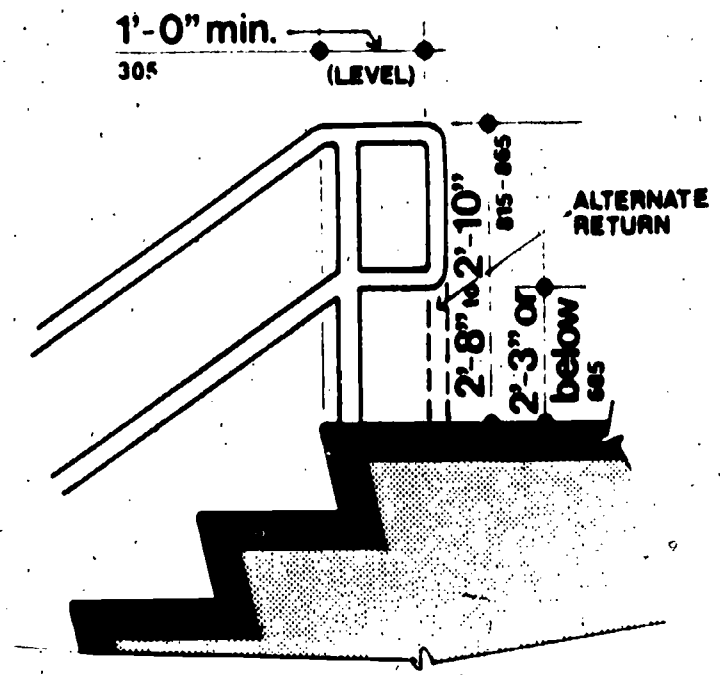

elevation of center handrail

Stair Handrails and Extensions

Figure 12

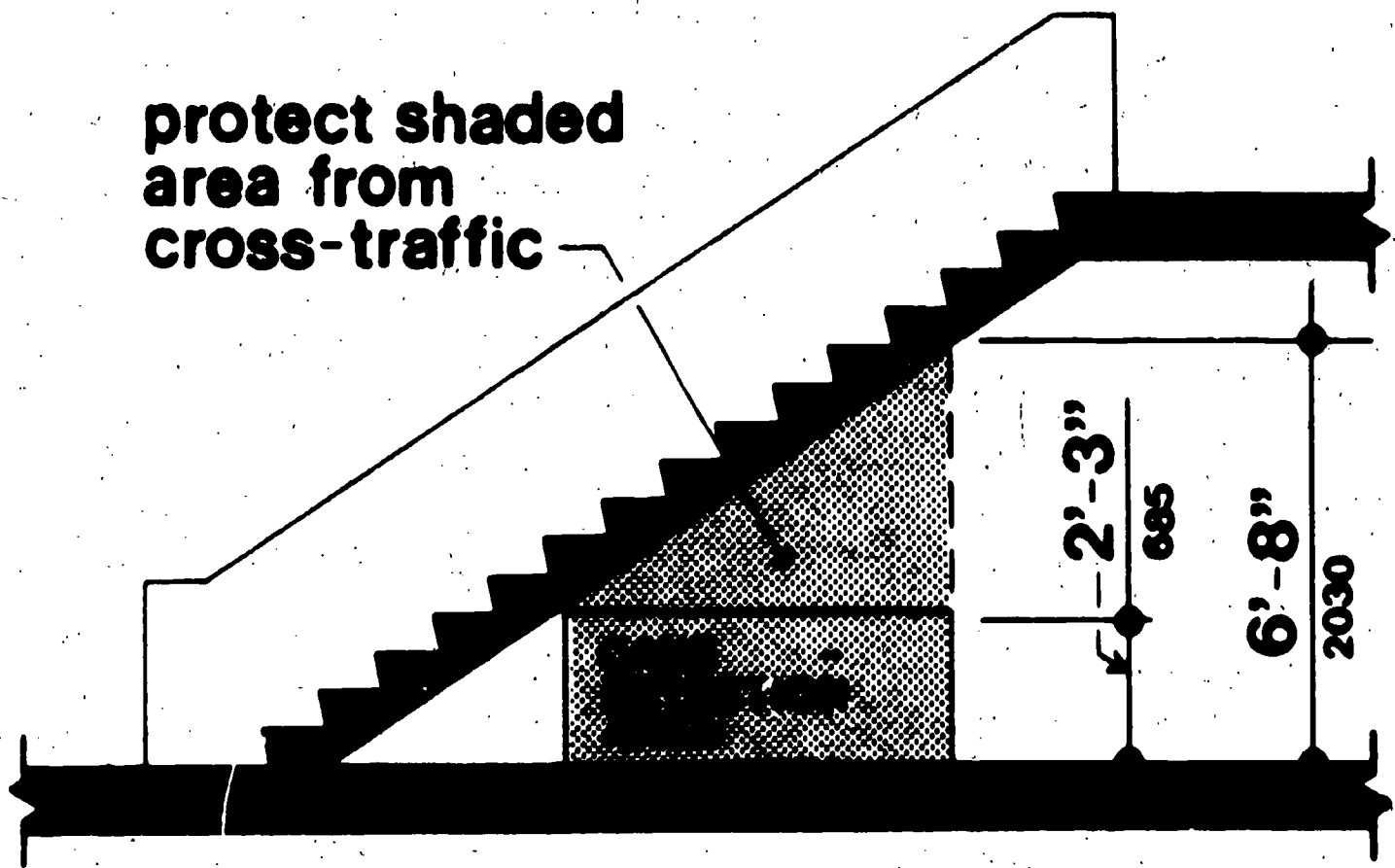

protect shaded
area from
cross-traffic

2'-3"

685

6'-8"

2030

Overhead Clearance

Figure 13

- 4.11.2 Provide horizontally sliding car and hoistway doors opened and closed by automatic means. For detailed requirements, see ANSI A17.1.
- 4.11.2.1 The minimum clear width for elevator doors shall be 4'-0".
- 4.11.2.2 Provide a door reopening device which will function to stop and reopen a car door and adjacent hoistway door in case a car door is obstructed while closing. The reopening device shall also be capable of sensing an object or person in the path of a closing door without requiring contact for activation at a nominal 5" and 2'-4" above the floor. Door opening devices shall remain effective for a period of not less than 20 seconds.
- 4.11.2.3 The minimum acceptable time from notification that a car is answering a call (lantern and audible signal) until the doors of that car start to close shall be as indicated in Fig. 14. The distance shall be established from a point in the center of the corridor or lobby (maximum 5'-0") directly opposite the farthest hall button to the centerline of the hoistway entrance. (See Fig. 14). The minimum acceptable time for doors to remain fully open shall be 3 seconds.
- 4.11.3 In an accessible elevator car, the minimum clear distance between wall and door, excluding return panels, shall be no less than 6'-8" x 4'-6" (2,500-1b car). The minimum distance from wall to return panel shall not be less than 4'-3".
- 4.11.4 Provide an auxiliary control panel, equipped with emergency controls. The auxiliary panel shall be mounted either in the front panel, opposite the main car operating panel or in the sidewall adjacent to the entrance strike jamb. The auxiliary panel shall be centered at 3'-0" above the car floor. (See Fig. 15) Use symbols as indicated in Fig. 15, to assist in readily identifying car controls.
- 4.11.4.1 Floor registration buttons, exclusive of border, shall be a minimum of 3/4" in size and raised. Provide visual indication that each call is registered and is extinguished when the call is answered. Call and operating buttons shall be raised and illuminated.
- 4.11.4.2 Provide markings on a contrasting color background to the left of the controls. Letters or numbers shall be a minimum of 5/8" and raised .030". Applied plates permanently attached shall be acceptable.

travel distance		time
ft	m	sec
0-7.5	0-2.3	5
10	3	7
15	4.5	10
20	6	13

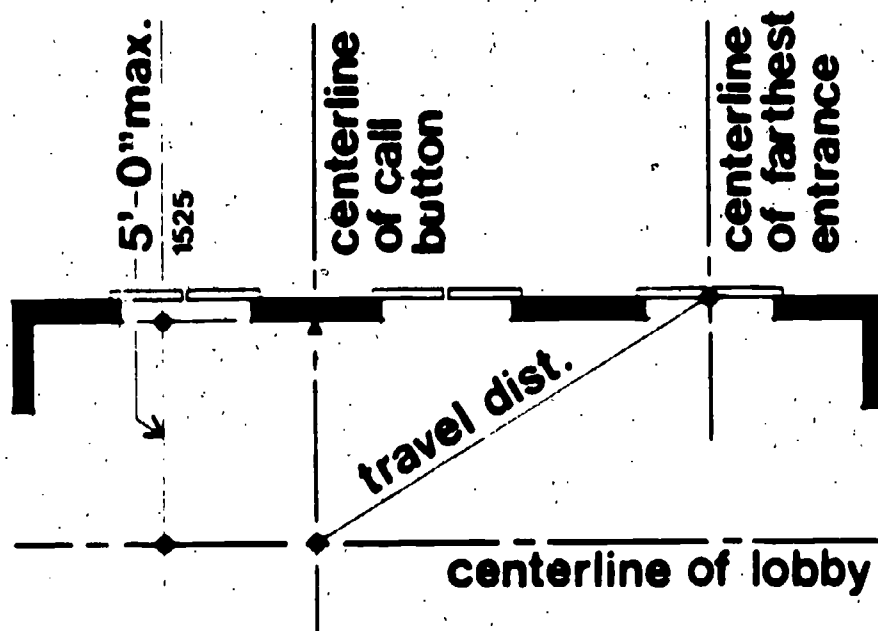

Time and Travel Distance

Figure 14

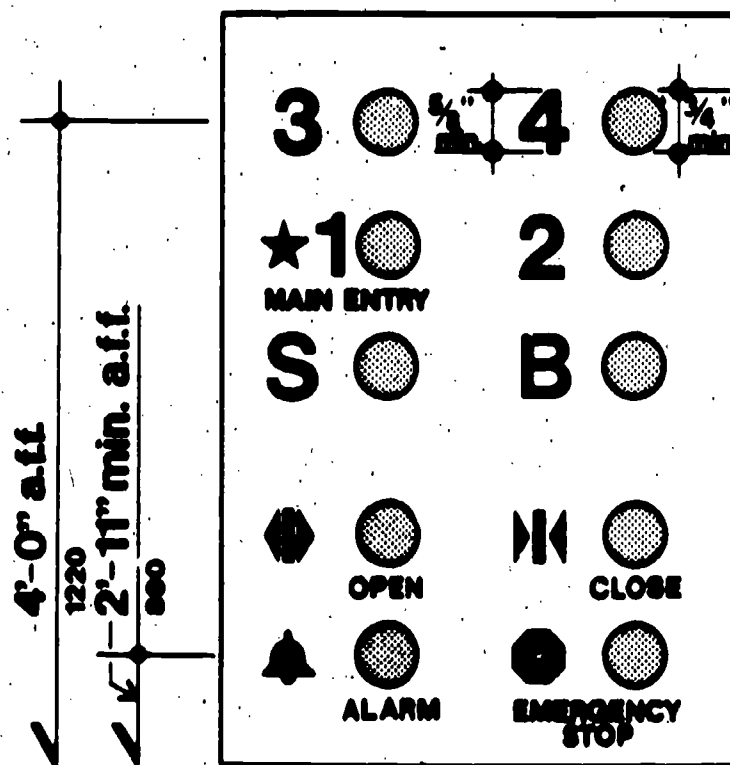
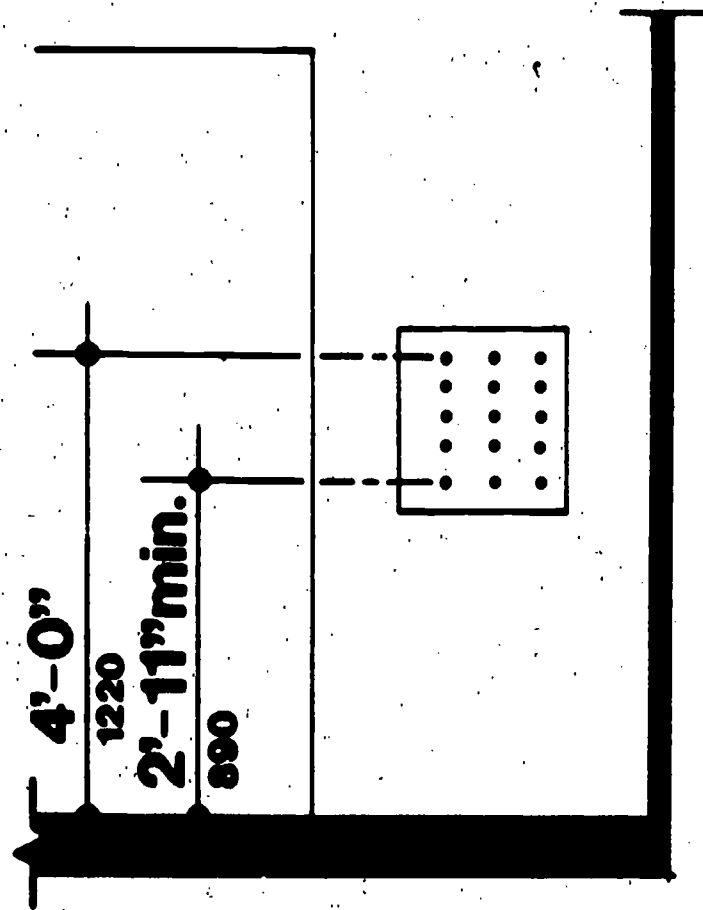

Auxiliary Elevator Control Panel

Figure 15

- 4.11.5 Provide a visual car position indicator above the car control panel or over the door to show the position of the elevator in the hoistway. As the car passes or stops at a floor served by the elevator, the corresponding numeral shall illuminate and an audible signal shall sound. Numerals shall be a minimum of 2" high. The audible signal shall be no less than 20 decibels with a frequency no higher than 1500 Hz. An automatic verbal announcement of the floor number at which a car stops or which a car passes may be substituted for the audible signal.
- 4.11.6 Provide a means of two-way communication between the elevator car and an area staffed 24 hours a day. This system shall consist of an emergency intercom station activated by the alarm button. The operating mechanism shall be mounted in the auxiliary panel.
- 4.11.7 Floor covering in the car shall have a nonslip, firm surface which permits easy movement of wheelchairs. Carpeting is not used.
- 4.11.8 Install double handrails on the rear and two sidewalls of the car with the tops of the handrails measuring 2'-6" and 3'-6", respectively, above the finished floor of the car. The nominal diameter or cross section of the gripping surface of a handrail shall be 1-1/2". The edges of noncircular handrail sections shall have a minimum radius of 1/8". Handrails shall be smooth and there shall be a 1-1/2" space between the handrails and car walls.
- 4.11.9 The minimum illumination of car controls, platform, car threshold and landing sill shall be 20 foot-candles.
- 4.11.10 The centerline of the hall call buttons shall be 3'-4" above the finished floor. Mount the button designating "up" on top. Direction buttons, exclusive of border, shall be a minimum of 3/4" in size. Provide a visual indication which shows when each call is registered and is extinguished when the call is answered. Do not mount hall call buttons above wall-mounted ash receptacles.
- 4.11.11 Provide a visual and audible signal at each hoistway entrance indicating the car answering the call and its direction of travel. Mount the visual signal above the hoistway entrance. The visual signal for each direction shall be a minimum of 2-1/2" in size and visible from the proximity of the hall call button. The audible signal shall sound once for the "up" direction and twice for the "down" direction.

- 4.11.12 Provide floor designations at each hoistway entrance on both jambs. The door jamb markings shall be mounted at 5'-0" above the finished floor. Applied plates permanently attached shall be acceptable.
- 4.12 **Platform Lifts.** Platform lifts, erected to accommodate handicapped users, shall be capable of safely and comfortably transporting an occupied wheelchair, and shall be fully operable by the occupant or aide. All operating controls shall be mounted within easy reach and no higher than 3'-4". Platform minimum size is 12 square feet (3'-0" wide by 4'-0" deep). Maximum size is 18 square feet. Minimum capacity is 450 lbs. A clear floor space of 5'-0" x 5'-0" shall be provided at the point of entrance to and exit from the platform lift.
- 4.13 **Toilet Rooms.** All public and common use toilet rooms shall be accessible. Number and location of accessible patient and staff toilet rooms shall comply with VA Handbook H-08-9, "Planning Criteria for VA Facilities." Accessible toilet facilities shall be located along an accessible path of travel and have accessible fixtures, accessories, doors and adequate maneuvering clearances which comply with the criteria in this section.
- 4.13.1 Public and staff accessible toilet rooms shall be identified by posting the "International Symbol of Accessibility" on or adjacent to the entry door. (Refer to the VA manual M-00-2, "Signage System Standards Manual," as prescribed by VA Construction Standard 15-2.)
- 4.13.2 Entrance doorways to toilet rooms shall have a minimum clear width of 2'-10". Doors shall not swing into the clear floor space required for any fixture.
- 4.13.3 Privacy screens or walls shall conform to VA Architectural Standard Detail No. 12A.
- 4.13.4 The toilet room shall have a minimum unobstructed floor space of 5'-0" in diameter, measured 1'-0" above the floor, for turning a wheelchair without conflict with overhanging fixtures or plumbing. Provide an unobstructed floor space of 4'-0" x 4'-0" in front of the stall door.
- 4.13.5 Where towel racks, disposal units, dispensers, vending machines, and appliances are provided, at least one of each type shall be mounted with operating mechanisms or controls located no higher than 3'-4" above the finished floor. Controls shall comply with the requirements in section 4.16, "Controls."

- 4.13.5.1 Where mirrors are provided, at least one shall have the bottom edge of its viewing surface mounted no higher than 3'-4" above the finished floor.
- 4.13.5.2 Where shelves are provided, at least one shall be mounted no higher than 3'-4" above the finished floor.
- 4.13.6 All accessible toilet rooms with stalls shall have a minimum of one Type "A" stall (side-transfer stall). A Type "A" stall shall measure a minimum of 5'-6" wide by 6'-0" deep, clear internal dimensions. Refer to Fig. 16 and VA Architectural Standard Detail No. 12 for dimensions and arrangements of elements within a Type "A" stall.
- 4.13.6.1 **Exception.** In areas other than SCI areas, where removal of an existing water closet in a toilet room to be renovated would conflict with applicable regulations or code requirements governing the number of water closets for the particular facility type, the renovated toilet room shall have at least one Type "B" stall (front-transfer stall).
- 4.13.6.2 A Type "B" stall shall measure a minimum of 3'-6" by 6'-6" deep, clear dimensions. Refer to Fig. 16 and VA Architectural Standard Detail No. 12 for dimensions and arrangement of elements within a Type "B" toilet stall.
- 4.13.6.3 Doors to accessible toilet stalls shall swing out. Doorways shall have a minimum clear width of 2'-8".
- 4.13.7 Accessible water closets shall be mounted at a height of 1'-4", measured from the finished floor to the top of the rim.
- 4.13.7.1 **Exception.** Water closets for SCI patients shall be mounted at a height of 1'-3", measured from the finished floor to the top of the rim.
- 4.13.7.2 Flush controls shall be hand operated and mounted no higher than 3'-4" above the finished floor.
- 4.13.8 Position grab bars as shown in Fig. 16. Grab bars shall be mounted at a height of 2'-9", measured from the finished floor to the center line of the grab bar. There shall be a clear space of 1-1/2" between the mounting surface and the grab bar. The diameter or width of the gripping surface of a grab bar shall be 1-1/2".
- 4.13.8.1 Grab bar sections shall have no sharp edges and shall permit the continuous sliding of hands. Wall surfaces behind grab bars shall be smooth and free of sharp protrusions.

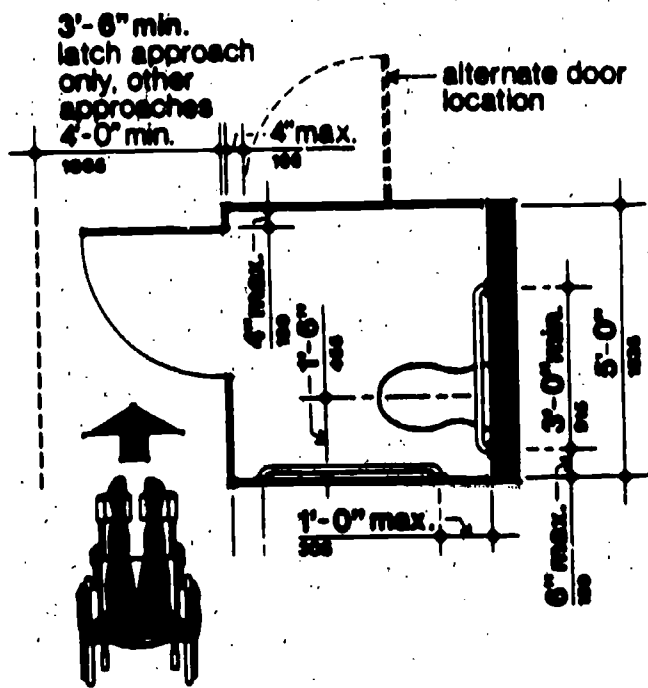

standard stall

A

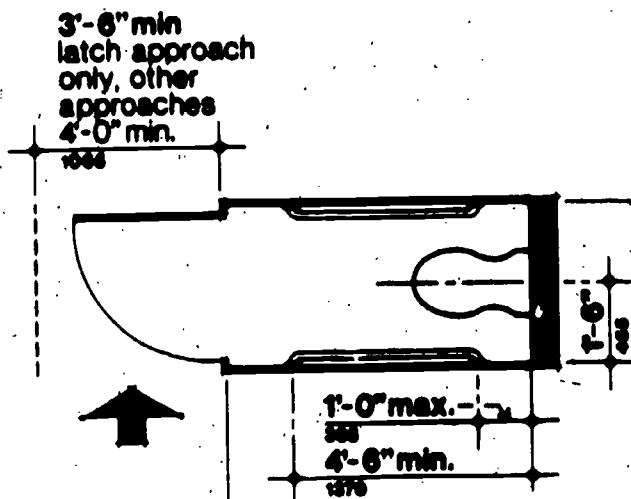
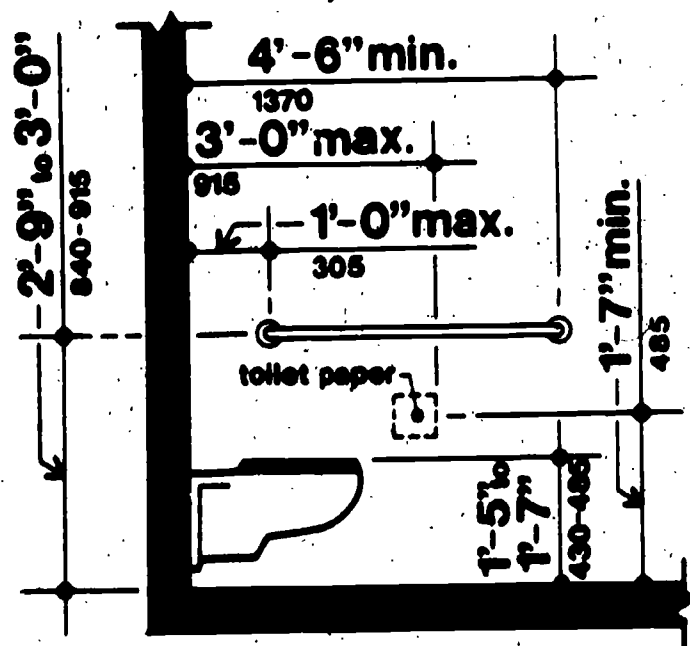

alternate stall

B

Toilet Stalls

Figure 16

4.13.8.2 The anchoring components of grab bars shall be capable of supporting a 250-lb force applied in any direction along the grab bar.

4.13.9 Where urinals are provided in toilet rooms, at least one urinal shall be accessible. The urinal shall have an elongated lip and shall be wall mounted, with the basin opening 1'-3" above the finished floor. The flush control shall be hand operated and mounted no higher than 3'-4" above the finished floor.

4.13.9.1 Provide an unobstructed floor space of 2'-6" x 4'-0" in front of the urinal to allow forward approach, even where urinal shields are used.

4.13.10 At least one lavatory in an accessible toilet room shall comply with VA Architectural Standard Detail No. 15 or 53D.

4.13.10.1 **Exception.** In SCI patient rooms, lavatories shall comply with VA Architectural Standard Detail No. 53.

4.14 **Water Fountains.** Water fountains shall comply with VA Architectural Standard Detail No. 4C.

4.14.1 Spouts shall be no higher than 3'-0", measured from the floor or ground surface to the spout outlet. The spouts of drinking fountains and water cooler shall be at the front of the unit and shall direct the water flow in a trajectory that is parallel or nearly parallel to the front of the unit. The spout shall provide a flow of water at least 4" high so as to allow the insertion of a cup or glass under the flow of water.

4.14.2 Controls shall be front mounted or side mounted near the front edge.

4.15 **Public Telephones.** Where public telephones are provided, at least one telephone at each location shall be a forward-approach telephone.

4.15.1 Provide pushbutton controls for accessible telephones where service for such equipment is available. The highest operable part of accessible telephones shall be a maximum of 4'-0" above the finished floor. (See Fig. 17)

4.15.2 Accessible telephones shall have an unobstructed floor approach of at least 2'-6" x 4'-0". (See Fig. 17) Telephones, telephone enclosures, telephone booths and seats shall not reduce the required minimum clear width of accessible paths of travel.

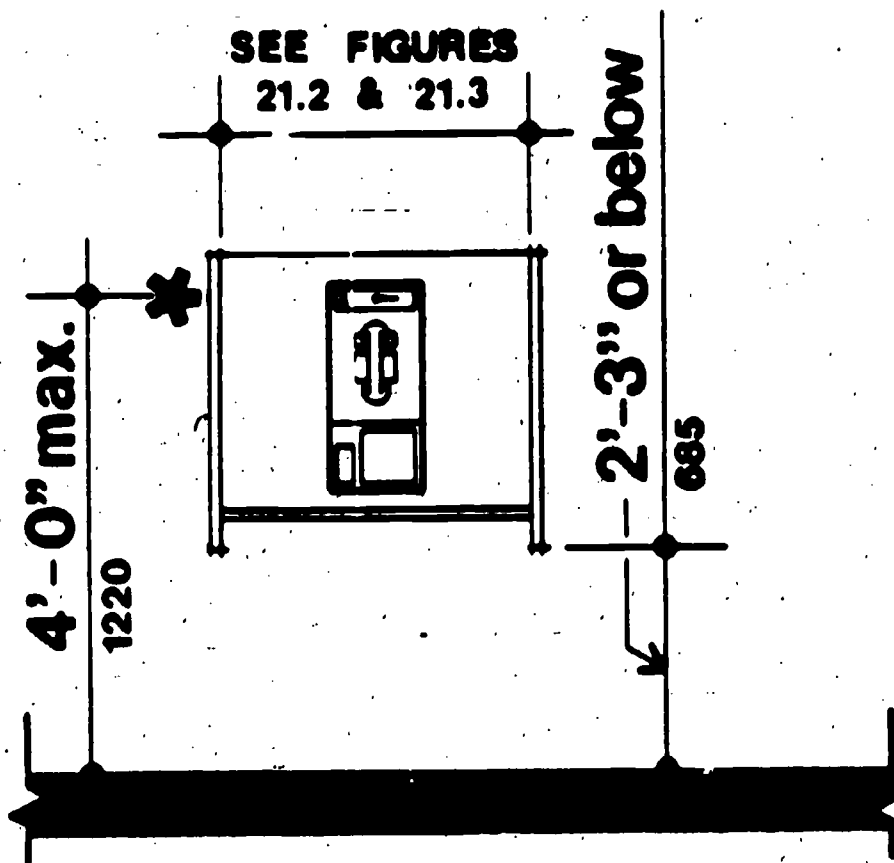

* HEIGHT TO HIGHEST OPERABLE PARTS
WHICH ARE ESSENTIAL TO THE BASIC
OPERATION OF THE TELEPHONE

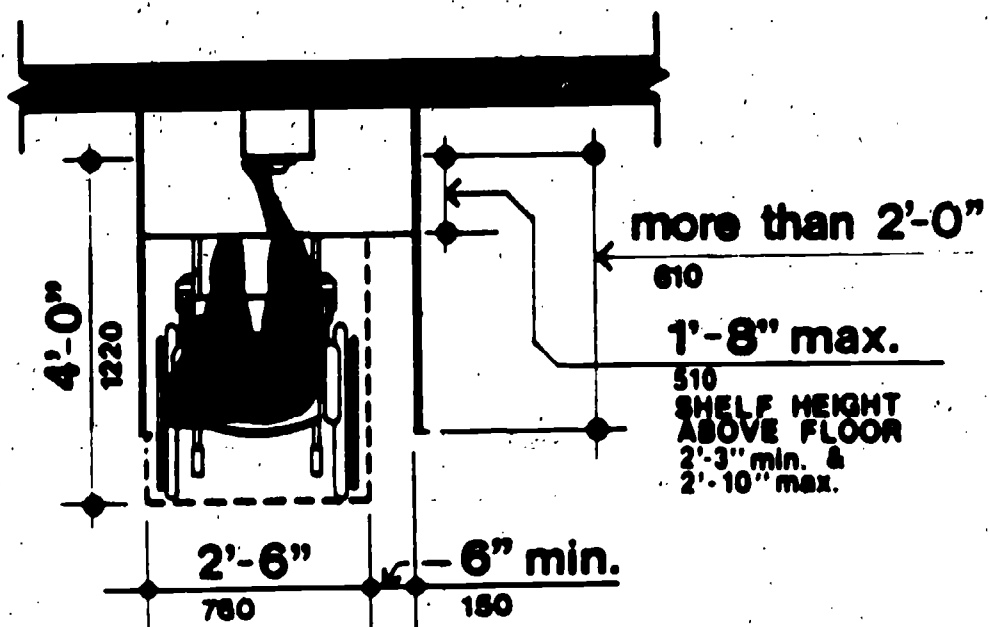

Public Telephones

Figure 17

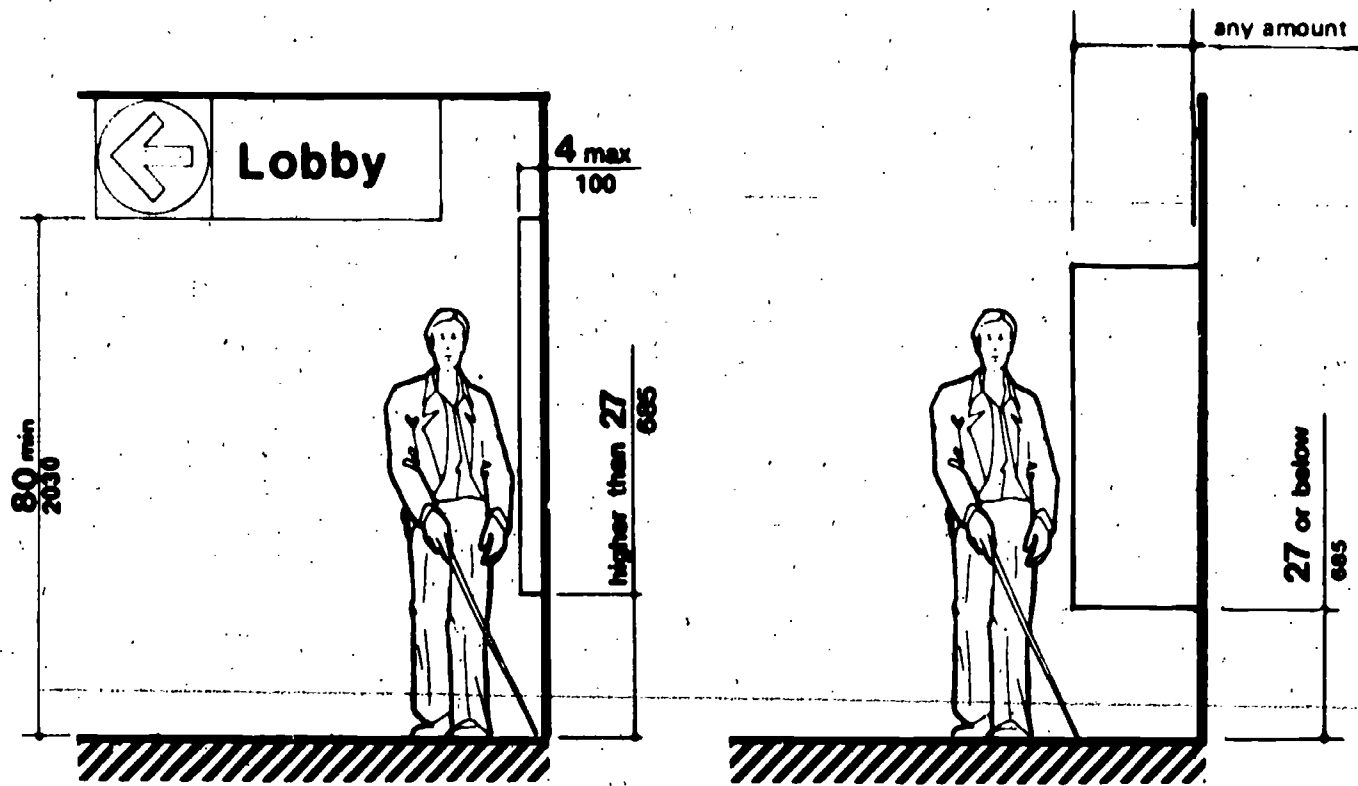

NOTE: cane hits post or pylon before person hits object

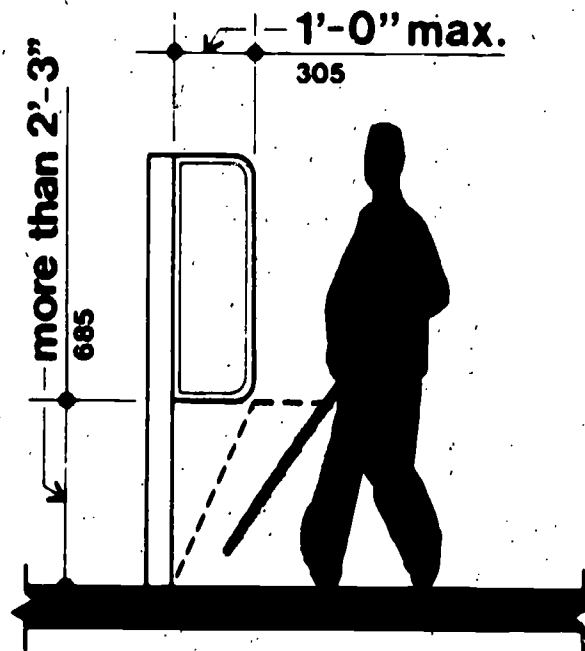

Projecting Objects

Figure 18

- 4.19 Carpets.** Carpet or carpet tile used on an accessible ground or floor surface shall be securely attached with no cushion or pad. It shall have a level loop low profile or a level cut pile low profile. The maximum pile or combined pile and cushion thickness shall not exceed 1/4". Exposed edges of carpet shall be fastened to floor surfaces and have trim along the entire length of the exposed edge. Carpet edge trim shall comply with Section 4.8, "Floors."
- 4.20 Cafeteria and Retail Store Facilities.** Access aisles between tables, food serving lines, and display aisles shall have a minimum width of 3'-0". Tray lines shall be continuous through serving and dispensing areas to cashier stations as shown on VA "List of Dietetic Equipment Symbols," Detail 502/7.
- 4.20.1** At least one cutlery and supply rack shall be within easy reach of wheelchair users and not exceed 3'-4" in height above the finished floor.
- 4.20.2** At least 5% of the tables shall have knee clearance of 2'-5" above the finished floor. The clearance shall not be obstructed by bracing, skirts, fascias, or table bases.
- 4.21 Patient Bedrooms.** Each bedroom shall have a minimum clear turning space of 5'-0" in diameter, preferably located near the entrance.
- 4.21.1** In each bedroom there shall be a minimum clear floor space of 3'-0" between the side of the bed and the wall; 3'-6" between the foot of the bed and wall; and 4" between the head of the bed and the wall. In addition, in each multi-bed room there shall be a minimum clear floor space of 4'-0" between beds and 4'-0" from foot to foot of beds.
- 4.21.2** Accessible patient toilet rooms shall comply with section 4.13, "Toilet Rooms," and VA Architectural Standard Detail No. 12.
- 4.21.3 Exception.** Where water closets are equipped with bedpan washers, split handrails may be used on the rear wall.
- 4.22 Special Consideration Areas.** Assembly areas, waiting areas, medical and examination rooms, libraries and lounges shall have accessible entrances (minimum clear width of 2'-10"); accessible paths of travel (minimum clear width of 3'-0"); and adequate clear floor space for wheelchair maneuverability (a 5'-0" turning diameter).

- 4.22.1 Spectator areas shall provide level floor spaces, on accessible routes, for handicapped viewing positions which will accommodate at least 3% of the spectator capacity. (See Fig. 19 for minimum clear floor space)
- 4.22.2 Spectator areas, accommodating 50 or more persons, and equipped with amplification systems, shall have a listening system to assist no fewer than two persons with severe hearing loss. Where the listening system provided serves individual seats or viewing areas, such seats or areas shall be located within a 50-foot viewing distance of the stage or program area. For spectator areas accommodating 50 or more persons without amplification systems, provide a portable listening system to assist persons with severe hearing impairments. Audio loops and radio frequency systems are two acceptable types of listening systems.

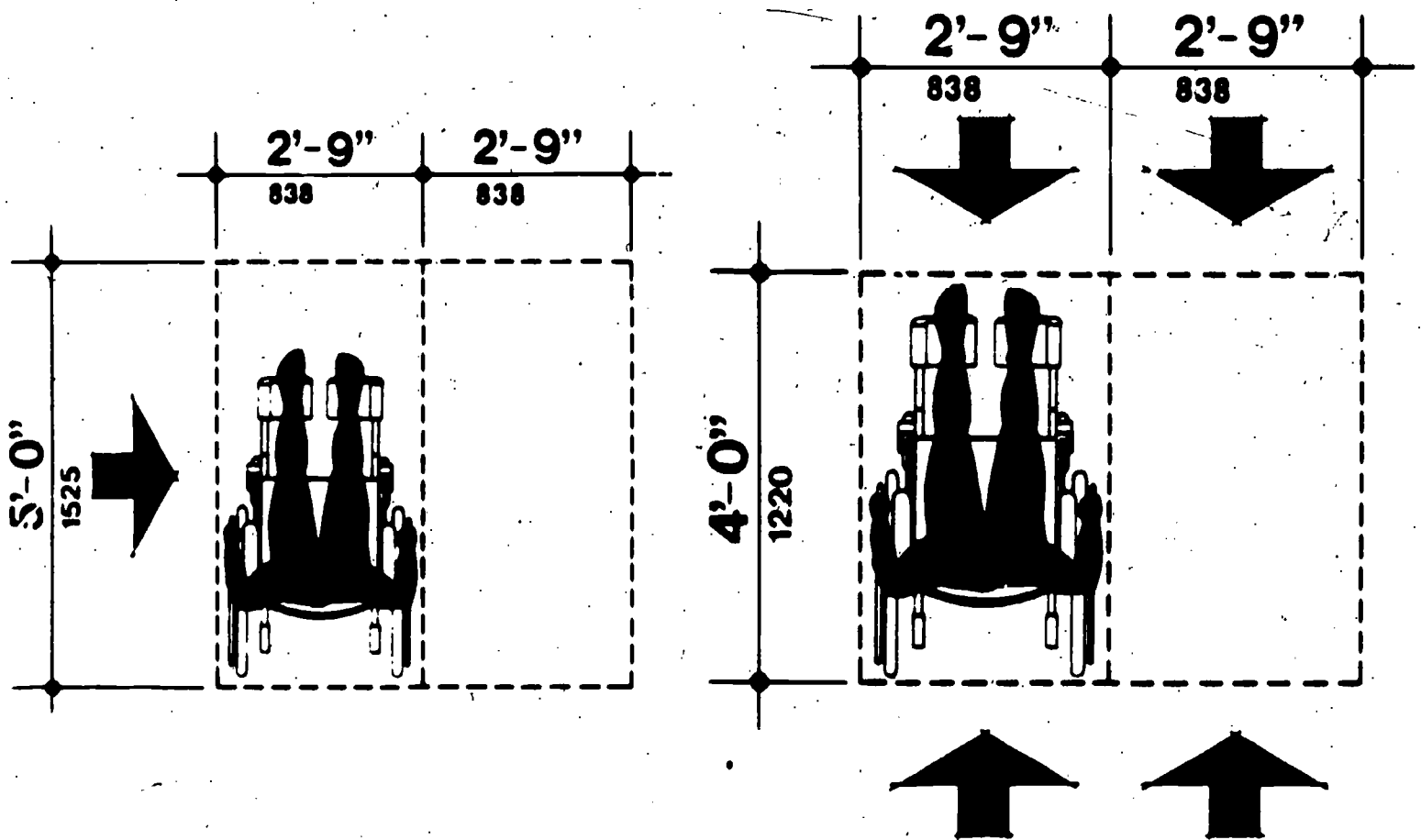

Wheelchair Viewing Areas

Figure 19

**CHECKLIST
FOR
BARRIER FREE DESIGN**

VA FACILITY/PROJECT _____

LOCATION _____

This checklist is intended for in-house use for, but not limited to, the following purposes:

- (1) By A/E's, VA project leaders and Construction personnel in the preparation and/or review of project layouts, plans, specifications, architectural details and construction to insure the incorporation of minimum accessibility requirements.
- (2) In reviews of all VA new construction, addition and renovation projects for accessibility compliance.
- (3) In surveys of existing VA facilities for barrier free deficiencies.

The initial headings and numbering sequence of the checklist sections conform to the format employed in the body of this handbook to allow for convenient cross referencing.

	YES	NO
4.1 Passenger Loading Area		
a. In a safe area and clearly designated for passenger arrival and departure.	_____	_____
b. Close as possible to accessible entrance.	_____	_____
c. Zoned to prohibit parking.	_____	_____
d. Ramped to sidewalk level.	_____	_____
e. Access aisles, measuring at least 5'-0" wide by 20'-0" long and parallel and level with the vehicle pull-up space.	_____	_____
f. Passenger loading areas at health care facilities are protected by canopy or roof overhang.	_____	_____
g. Communication system for assistance provided at Spinal Cord Injury (SCI) units.	_____	_____

YES

NO

4.2 Walks

- a. Free of steps or abrupt changes of level.
- b. Minimum width of 5'-0".
- c. Maximum gradient of 1:33 (otherwise considered a ramp complying with Section 4.5, "Ramps").
- d. Cross slopes no greater than 1:96.
- e. Walks with gradients from 1:50 to 1:33 have rest areas every 200'.
- f. Changes in level are blended to common level by grading, curb cuts or ramps.
- g. Firm, nonslip surface.
- h. Free of gratings, manholes, etc.
- i. Level platforms (minimum of 6'-0" x 6'-0") at doors.

_____	_____
_____	_____
_____	_____
_____	_____
_____	_____
_____	_____
_____	_____
_____	_____
_____	_____
_____	_____

4.3 Parking

- a. Number of accessible parking spaces are provided as follows:
 Approximately 3% of employee and visitor spaces.
 At outpatient facilities, 10% of total number of parking spaces.
 At SCI facilities, a dedicated lot with 1.5 spaces for each SCI bed.
- b. Located conveniently to accessible entrances.
- c. Identified by accessibility symbols and routing signage where necessary.
- d. Spaces are at least 8'-0" wide with access aisles on each side.
- e. Spaces 11'-0" wide with access aisles for specially adapted vans.

_____	_____
_____	_____
_____	_____
_____	_____
_____	_____
_____	_____
_____	_____
_____	_____
_____	_____
_____	_____

YES

NO

f. Access aisles are at least 5'-0" wide with surface slope not exceeding 1:50.

g. Smooth transition from access aisle to adjacent walkway.

h. Minimum clear width of adjacent walkways not reduced by vehicle overhang.

4.4 Curb Ramps

a. Provided wherever a walk crosses a curb.

b. Located or protected to prevent obstruction by parked vehicles or street furnishings.

c. Maximum slope, 1:12.

d. Minimum width, 3'-0".

e. Smooth transition from curb ramp to street or grade level.

f. Firm, slip-resistant surface.

4.5 Ramps

a. Maximum slope, 1:12, preferably 1:20.

b. Slope of 1:33 to 1:24: ramp no greater than 40' in length.

c. Slope of 1:25 to 1:20: ramp no greater than 35' in length.

d. Cross slope no greater than 1:96.

e. Minimum clear width, 4'-0".

f. Top and bottom landings are at least 5'-0" long.

g. Intermediate landings at 30' intervals are at least 5'-0" long.

YES NO

h. Where doors swing onto a ramp landing, the landing is level and at least 6'-0" x 6'-0".

i. Where required, handrails are installed on both sides.

Handrails are mounted at a height of 2'-8" and extend 1'-0" beyond beginning and end of ramp.

j. Firm, slip-resistant surface.

k. Ramp curbs are at least 4" high by 4" wide.

4.6 Entrances

a. All main, outpatient, and other highly used entrances are accessible.

b. They are connected by an accessible walk to accessible parking and public streets.

c. They are connected to all accessible elements (e.g. elevators and ramps) and spaces throughout a building by paths of travel at least 3'-0".

d. Signage at accessible entrances.

4.7 Doors and Doorways

a. Minimum 3'-8" door to all patient bedrooms.

Minimum 3'-10" door to all patient bedrooms in SCI units.

b. Minimum 2'-10" clear opening to all other rooms.

c. Level approaches to doors.

d. 1'-6" clearance at latch side of all doors, except patient bedroom doors.

e. Minimum clearance between manual doors in series, 4'-0" plus the width of the door.

YES NO

- f. Maximum opening force for interior hinged doors is 5 lbf.
- g. Thresholds are flush with finished floor or beveled with a slope no greater than 1:2.
- h. Operating devices on doors are easy to operate with one hand.
- i. Knurled surface on operating hardware of doors leading to hazardous areas.
- j. Bottom rail (kickplate) is at least 1'-0" high.
- k. Automatic doors are used in high-use areas.

_____	_____
_____	_____
_____	_____
_____	_____
_____	_____
_____	_____

4.8 Floors

- a. Firm and slip-resistant surface.
- b. Changes in level between 1/4" and 1/2" are beveled with a slope no greater than 1:2. (Changes in level up to 1/4" require no edge treatment.)
- c. Changes in level greater than 1/2" comply with Section 4.5, "Ramps."
- d. All floors on which SCI services are provided are free from changes of level.

_____	_____
_____	_____
_____	_____
_____	_____

4.9 Corridor Handrails

- a. 1-1/2" diameter.
- b. 1-1/2" space between handrail and mounting surface.
- c. Height of handrails, 3'-0".
- d. Handrail sections are free of sharp edges.
- e. Wall surfaces behind handrails are smooth.
- f. Ends of handrails are rounded.

_____	_____
_____	_____
_____	_____
_____	_____
_____	_____
_____	_____

YES

NO

4.10 Stairs

- a. Minimum width of stairs, 3'-8".
- b. Treads and risers are of uniform size on a single flight of stairs.
- c. Maximum riser height, 7".
- d. Closed risers.
- e. Minimum tread width, 11".
- f. Slip-resistant tread surface.
- g. Nosings neither abrupt nor square.
- h. Handrails on both sides of stair.
 - 1-1/2" diameter.
 - 1-1/2" space between handrail and mounting surface.
 - Height of handrails, 2'-8".
 - Handrails are free of sharp edges.
 - Wall surfaces behind handrails are smooth.
 - Ends of handrails are smooth.
 - Handrails extend 1'-11" on one side beyond the top riser and 1'-11" on one side beyond the bottom riser.
- i. Stairways are well illuminated.

_____	_____
_____	_____
_____	_____
_____	_____
_____	_____
_____	_____
_____	_____
_____	_____
_____	_____
_____	_____
_____	_____
_____	_____
_____	_____
_____	_____
_____	_____
_____	_____
_____	_____
_____	_____
_____	_____
_____	_____
_____	_____

4.11 Elevators

- a. In multi-story facilities each level is served by an elevator, interior ramp or platform lift.
- b. Automatic operation.
- c. Self-leveling plus/minus 1/2".
- d. Minimum clear width of elevator doors, 4'-0".

_____	_____
_____	_____
_____	_____
_____	_____

	YES	NO
e. Doors are equipped with safety reopening device.	_____	_____
f. Minimum car size, 6'-8" x 4'-6".	_____	_____
g. Auxiliary control panel, centered at 3'-0" above car floor.	_____	_____
h. Hall call buttons, centered at 3'-4" above the finished floor.	_____	_____
i. Call and operating buttons, raised and illuminated.	_____	_____
j. Audible and visual signals operate when the car is passing through the floors it serves.	_____	_____
k. Emergency alarm system.	_____	_____
l. Intercom system.	_____	_____
m. Double set of handrails, 2'-6" and 3'-6".	_____	_____
n. Floor surface of car is firm and slip resistant.	_____	_____

4.12 Platform Lifts

a. Capable of safely and comfortably transporting an occupied wheelchair.	_____	_____
b. Fully operable by wheelchair occupant or aide.	_____	_____
c. Controls mounted within easy reach and no higher than 3'-4".	_____	_____
d. Clear floor space of 5'-0" x 5'-0" at the point of entrance to and exit from the lift.	_____	_____

4.13 Toilet Rooms

a. Public and common use toilet rooms are usable by the physically handicapped.	_____	_____
b. Signage for accessible toilet rooms.	_____	_____

	YES	NO
c. Minimum width of entrance doors to toilet rooms, 3'-0".	_____	_____
d. Minimum space between vestibule doors, 4'-0" plus the width of the door swinging into the space.	_____	_____
e. Clear turning space of 5'-0".	_____	_____
f. Minimum clear width of doorways to toilet stalls, 2'-8".	_____	_____
g. Wheelchair "side-transfer stall", minimum 5'-6" wide x 6'-0" deep.	_____	_____
h. Wheelchair "front-transfer stall", minimum 3'-6" wide by 6'-6" deep.	_____	_____
i. Water closet, top of rim 1'-4" above finished floor (1'-3" in SCI units).	_____	_____
j. Grab bars, 2'-9" above finished floor. 1-1/2" in diameter. 1-1/2" space between grab and mounting surface. Handrails are free of sharp edges. Wall surfaces behind grab bars are smooth.	_____	_____
k. Urinal basin lip, 1'-3" above finished floor.	_____	_____
l. Lavatory, minimum underneath clearance of 2'-5".	_____	_____
m. Faucets easily operated (preferably lever type).	_____	_____
n. Mirrors, shelves and dispensers, a maximum height of 3'-4" above finished floor.	_____	_____

4.14 Water Fountains

a. Installed as shown on VA Architectural Standard Detail No. 4C.	_____	_____
b. Spout height no higher than 3'-0".	_____	_____

YES

NO

4.15 Public Telephones

- a. If public telephones are provided, at least one telephone at each location is a forward-approach telephone usable by the physically handicapped.
- b. Pushbutton controls (if such equipment service is available).
- c. The highest operable part, 4'-0" above the finished floor.
- d. Unobstructed floor approach, a minimum of 2'-6" x 4'-0".
- e. Equipped with receiver that generates a magnetic field in the area of the receiver cap.
- f. At least one public telephone in the facility or building is equipped with a volume control.

_____	_____
_____	_____
_____	_____
_____	_____
_____	_____
_____	_____

4.16 Controls

- a. Mounting height, no higher than 3'-4" and no lower than 1'-3".
- b. Operation of controls require the least amount of hand or wrist movement.

_____	_____
_____	_____

4.17 Alarms

- a. Warning signals are both visual and audible.
- b. Pull stations mounted no higher than 4'-0", measured from finished floor to centerline of the device.

_____	_____
_____	_____

4.18 Hazards

Accessible paths of travel are free of hazardous side protrusions.

_____	_____
-------	-------

YES NO

4.19 Carpet

Carpet is securely attached and has a low-cut pile and tight weave.

4.20 Cafeteria Facilities

a. Access aisles and food serving lines are at least 3'-0" wide.

b. At least one cutlery and supply rack is no higher than 3'-4".

c. At least 5% of tables have a knee clearance of at least 2'-5".

4.21 Health Care Facilities

a. Each patient bedroom has:

i. Each patient bedroom has a clear turning space of at least 5'-0" between side of bed and wall.

ii. Clear floor space of at least 3'-0" between side of bed and wall.

iii. Clear floor space of at least 3'-6" between foot of bed and wall.

iv. Clear floor space of at least 4'-0" between beds and 4'-0" from foot to foot of beds.

b. Patient toilet rooms comply with Section 4.13, "Toilet Rooms."

YES

NO

4.22 Special Consideration Areas

- a. Waiting area: Accessible entrance (minimum clear width of 2'-10"); accessible paths of travel (minimum width of 3'-0"); and clear floor space for wheelchair maneuverability (5'-0" turning diameter).
- b. Medical and examination areas: (Same as 4.22(a)).
- c. Libraries and lounges: (Same as 4.22(a)).
- d. Assembly areas:
 - i. (Same as 4.22(a)).
 - ii. Spectator areas provide a reasonable number of handicapped viewing positions.
 - iii. Where required, listening systems for the hear-impaired persons are provided.

_____	_____
_____	_____
_____	_____
_____	_____
_____	_____
_____	_____

- 4.15.3 Accessible telephones shall be equipped with a receiver that generates a magnetic field in the area of the receiver cap. At least one accessible telephone in a building or facility shall be equipped with a volume control.
- 4.16 **Controls.** All controls intended for public or occupant use, for example, light switches, dispenser controls, etc., shall be placed along accessible paths of travel and in unobstructed locations accessible to handicapped individuals.
- 4.16.1 Controls shall be operable without the need for tight grasping, pinching or twisting of the wrist.
- 4.16.2 Mount controls no higher than 3'-4" above the finished floor unless specified in this handbook. Except where the use of special equipment dictates otherwise, mount electrical and communication system receptacles on walls no less than 1'-3" above the finished floor.
- 4.17 **Alarm Systems.** In facilities where alarm systems are required, provide both an audible and a visual signal.
- 4.17.1 Audible alarms shall produce a sound pressure level that exceeds ambient room or space noise by 15 decibels or any maximum noise level of 30-second duration by 5 decibels, whichever is greater. Sound levels for alarm signals shall not exceed 120 decibels.
- 4.17.2 A visual alarm device shall be provided adjacent to each exit door and near each audible alarm and shall flash in conjunction with the audible alarm. The frequency of visual alarms shall be less than 5 Hz. Both alarm signals shall operate from the same power source.
- 4.17.3 Install pull stations no higher than 4'-0", measured from the finished floor to the centerline of the device.
- 4.18 **Hazards.** Protrusions are potential hazardous objects within the detection range of canes. Protrusions shall not reduce the required minimum clear width of accessible paths of travel and shall not exceed 4" unless they are 2'-3", or less, from the finished floor. See Fig. 18.