

DOCUMENT RESUME

ED 202 470

IR 009 344

AUTHOR Goclowski, John C.; And Others
TITLE Digital Avionics Information System (DAIS): Impact of DAIS Concept on Life Cycle Cost. Final Report.
INSTITUTION Dynamics Research Corp., Wilmington, Mass.
SPONS AGENCY Air Force Human Resources Lab., Brooks AFB, Texas.
REPORT NO AFHRL-TR-81-4 (I)
PUB DATE Mar 81
CONTRACT F33615-75-C-5218
NOTE 80p.; For a related document, see IR 009 173.

EDRS PRICE MF01/PC04 Plus Postage.
DESCRIPTORS Aviation Technology; *Computer Oriented Programs; *Cost Effectiveness; *Information Systems; Input Output Devices; *Life Cycle Costing; Military Organizations; Military Personnel; *Personnel Needs

ABSTRACT

Designed to identify and quantify the potential impacts of the Digital Avionics Information System (DAIS) on weapon system personnel requirements and life cycle cost (LCC), this study postulated a typical close-air-support (CAS) mission avionics suite to serve as a basis for comparing present day and DAIS configuration specifications. The purpose at this stage of the study was to define, as much as possible, the effects of a DAIS architecture on such a suite, and to indentify the differences between the standard and the DAIS versions of the suite in terms of support requirements and LCC. The results of the comparison of the DAIS and non-DAIS show that the expected higher procurement cost for a DAIS system is offset by savings in recurring costs, especially those associated with manpower. (Author/MER)

* Reproductions supplied by EDRS are the best that can be made *
* from the original document. *

THIS DOCUMENT HAS BEEN REPRO-
DUCED EXACTLY AS RECEIVED FROM
THE PERSON OR ORGANIZATION ORIGIN-
ATING IT. POINTS OF VIEW OR OPINIONS
STATED DO NOT NECESSARILY REPRESENT OFFICIAL NATIONAL INSTITUTE OF
EDUCATION POSITION OR POLICY

AIR FORCE



HUMAN RESOURCES

ED202470

**DIGITAL AVIONICS INFORMATION SYSTEM (DAIS):
IMPACT OF DAIS CONCEPT ON LIFE CYCLE COST**

By

John C. Goelowski
John M. Glasier
Marjorie A. Bristol
Jonathan T. Frueh
Dynamics Research Corporation
60 Concord Street
Wilmington, Massachusetts 01887

H. Anthony Baran

LOGISTICS AND TECHNICAL TRAINING DIVISION
Wright-Patterson Air Force Base, Ohio 45433

March 1981

Final Report

Approved for public release; distribution unlimited.

LABORATORY

**AIR FORCE SYSTEMS COMMAND
BROOKS AIR FORCE BASE, TEXAS 78235**

TR009344

NOTICE

When U.S. Government drawings, specifications, or other data are used for any purpose other than a definitely related Government procurement operation, the Government thereby incurs no responsibility nor any obligation whatsoever, and the fact that the Government may have formulated, furnished, or in any way supplied the said drawings, specifications, or other data is not to be regarded by implication or otherwise, as in any manner licensing the holder or any other person or corporation, or conveying any rights or permission to manufacture, use, or sell any patented invention that may in any way be related thereto.

This final report was submitted by Dynamics Research Corporation, 60 Concord Street, Wilmington, Massachusetts 01887, under Contract F33615-75-C-5218, Project 205T, with the Logistics and Technical Training Division, Air Force Human Resources Laboratory (AFSC), Wright-Patterson Air Force Base, Ohio 45433. Mr. H. Anthony Baran was the Contract Manager for the Laboratory.

This report has been reviewed by the Office of Public Affairs (PA) and is releasable to the National Technical Information Service (NTIS). At NTIS, it will be available to the general public, including foreign nations.

This technical report has been reviewed and is approved for publication.

ROSS L. MORGAN, Technical Director
Logistics and Technical Training Division

RONALD W. TERRY, Colonel, USAF
Commander

Unclassified

SECURITY CLASSIFICATION OF THIS PAGE (When Data Entered)

REPORT DOCUMENTATION PAGE		READ INSTRUCTIONS BEFORE COMPLETING FORM
1. REPORT NUMBER AFHRL-TR-81-4(1)	2. GOVT ACCESSION NO.	3. RECIPIENT'S CATALOG NUMBER
4. TITLE (and Subtitle) DIGITAL AVIONICS INFORMATION SYSTEM (DAIS): IMPACT OF DAIS CONCEPT ON LIFE CYCLE COST		5. TYPE OF REPORT & PERIOD COVERED Final
		6. PERFORMING ORG. REPORT NUMBER
7. AUTHOR(s) John C. Gocłowski Jonathan T. Frueh John M. Glasier H. Anthony Baran Marjorie A. Bristol		8. CONTRACT OR GRANT NUMBER(s) F33615-75-C-5218
9. PERFORMING ORGANIZATION NAME AND ADDRESS Dynamics Research Corporation 60 Concord Street Wilmington, Massachusetts 01887		10. PROGRAM ELEMENT, PROJECT, TASK AREA & WORK UNIT NUMBERS 63243F 20510001
11. CONTROLLING OFFICE NAME AND ADDRESS HQ Air Force Human Resources Laboratory (AFSC) Brooks Air Force Base, Texas 78235		12. REPORT DATE March 1981
		13. NUMBER OF PAGES 76
14. MONITORING AGENCY NAME & ADDRESS (if different from Controlling Office) Logistics and Technical Training Division Air Force Human Resources Laboratory Wright-Patterson Air Force Base, Ohio 45433		15. SECURITY CLASS. (of this report) Unclassified
		15a. DECLASSIFICATION/DOWNGRADING SCHEDULE
16. DISTRIBUTION STATEMENT (of this Report) Approved for public release: distribution unlimited.		
17. DISTRIBUTION STATEMENT (of the abstract entered in Block 20, if different from Report)		
18. SUPPLEMENTARY NOTES The research reported herein was sponsored jointly by the Air Force Human Resources Laboratory, Air Force Avionics Laboratory, and Air Force Logistics Command. It was performed and funded as part of the Digital Avionics Information System Advanced Development Program.		
19. KEY WORDS (Continue on reverse side if necessary and identify by block number) Digital Avionics Information System maintenance cost analysis life cycle cost non-DAIS vs. DAIS concepts life cycle cost equations operation and support cost Life Cycle Cost Impact Model Reliability and Maintainability Model		
20. ABSTRACT (Continue on reverse side if necessary and identify by block number) The Digital Avionics Information System (DAIS) approach to avionics design is a total system concept rather than a functional subsystem or hardware-oriented system. DAIS uses common processing, information transfer, control and display, and support software elements to service all avionics functional areas on an integrated basis. Thus, the DAIS architecture and core elements are not dedicated to any one specific avionic function, but are used to perform the tasks of many avionic functions with the avionic sensors and subsystems. This systems approach provides flexibility to accommodate a wide variety of avionic configurations and missions, as well as redundancy to improve availability. Standardization and replication of the core elements can reduce the life cycle costs when major modifications/retrofits of an avionic configuration are considered, or when applied across the fleet by reducing unnecessary development proliferation and reducing maintenance costs.		

DD FORM 1 JAN 73 1473

Unclassified

SECURITY CLASSIFICATION OF THIS PAGE (When Data Entered)

4

Item 20 (Continued)

A limited assessment of the potential effects of the DAIS concept on avionics system life cycle cost is provided in this report by a cost comparison of a hypothetical application of a conceptual mid-1980s DAIS suite versus a conventional avionics suite in a close-air-support (CAS) aircraft. The impact of the DAIS concept on life cycle cost (LCC) was determined by using the Life Cycle Cost Impact Model (LCCIM) system to compare the two avionics configurations. Several additional applications of the LCCIM were used to assess the impact of standardization, retrofit, and inflation.

The results of this first-cut comparison of a DAIS versus a non-DAIS avionics configuration indicate that the LCC of DAIS is 4.3 percent lower for the selected scenario of 72 CAS aircraft operating over a 15-year period. Inflation has been considered and shown to increase this difference to 9.4 percent. In general, the higher procurement cost for a DAIS configuration seems to be well offset by its recurring savings in manpower costs. Standardization of DAIS core elements will affect LCC as a function of the number of aircraft and aircraft types that share this commonality. To demonstrate this fact, an analysis was made of the LCC impact of extending the DAIS concept application across six aircraft types, each with 72 aircraft. The LCC per aircraft was reduced by 5.5 percent (including only inflation factor). When one subsystem was added to the avionics configuration, the DAIS configuration accommodated the change with a 41 percent lower impact on LCC.

The second volume of this two volume report provides supplemental information concerning the cost comparison which includes appendices, model output reports, data used in the comparison, and details of the assumptions governing the comparison.

SUMMARY

BACKGROUND

This report describes an effort to identify and quantify the potential impacts of a new concept of avionics integration on weapon system personnel requirements and life cycle cost (LCC). The concept is the Digital Avionics Information System (DAIS) under development at the Air Force Avionics Laboratory. The techniques and models used in this analysis were developed specifically for the purpose of analyzing the potential impacts of alternate designs on system LCC based on data available in the conceptual stage of systems development. The objective was to develop tools and techniques necessary to assess the LCC implications of new system design concepts, and use them in an analysis of the potential of the DAIS concept of avionics integration to impact avionics LCC. This report describes that analysis and presents its results.

APPROACH

As a preliminary investigation, the analysis reported here provides a firm basis for gauging the possibilities afforded by the DAIS approach (as yet an incompletely defined approach to avionics standardization) to favorably impact the high cost and resource requirements of advanced weapon system ownership. The approach taken was: to postulate a typical close-air-support (CAS) mission avionics suite to serve as a baseline for comparing present day and DAIS configuration specifications; to define, as much as possible, the effects of a DAIS architecture on such a suite; and to identify and quantify the differences between the standard and DAIS versions of the suite in terms of support requirements and LCC.

The following guidelines were used in the analysis reported in this document.

1. Identification of the basic ground rules, assumptions, and constraints under which the DAIS LCC impact analysis would be conducted. The ground rules defined a hypothetical application of DAIS and non-DAIS configured avionics in a CAS aircraft. The assumptions and constraints defined the logistic environment and costing guidelines.
2. Identification of specific effects of a DAIS application with a plan for comparing what could be considered a reasonable DAIS application in an avionics suite to a suite which was functionally equivalent but of conventional configuration. This was accomplished through engineering analysis and the use of the Life Cycle Cost Impact Model (LCCIM) developed as a part of the overall effort.

3. Quantification of the cost difference between the DAIS and non-DAIS avionic suites using the LCCIM.

This report presents and discusses this comparative impact analysis and describes some of the limitations in concept definition, scope of application, and cost data availability which tend to bound the definitiveness of this type of analysis.

RESULTS

Basically, the DAIS is a concept of avionics architecture which simplifies the interfacing, joint operation, and installation of avionics subsystems within a total integrated system. Designed to reduce the proliferation of disparate avionics components by standardizing specifications and providing for increased functional and operational compatibility, the DAIS is expected to favorably impact weapon system LCC. That impact is anticipated to affect the major cost areas of research and development, system investment, support investment, and particularly, operating and support cost.

The results of the comparison of the DAIS and non-DAIS show that the expected higher procurement cost for a DAIS system is offset by savings in recurring costs, especially those associated with manpower. The DAIS life cycle cost was 4.3 percent lower than the conventional avionics for the chosen scenario of 72 CAS aircraft operating over a 15-year period. Inflation, if considered at a moderate six percent, can increase this difference to 9.4 percent.

Standardization affects LCC as a function of the number of aircraft and aircraft types that share a given commonality. When application of the DAIS concept was postulated across six aircraft types, each considered as a block of 72 aircraft, the LCC per aircraft avionics package was shown to be reduced by 14.9 percent relative to conventional avionics configurations.

An attempt was made to quantify the impact of the DAIS compatibility to facilitate system change. This was done by postulating the addition of a subsystem with little software requirements. The cost comparison for this selected subsystem addition indicated a 41 percent reduction in the LCC of the modification attributable to the DAIS avionics architecture of the total system. Another subsystem with considerable software requirements was postulated as a retrofit to each avionics configuration. The cost comparison for this subsystem addition indicated a 94 percent cost savings in LCC for DAIS over the capability of a conventional avionics configuration to facilitate this change.

This study assumes all CAS missions can be accomplished by one avionics configuration. Therefore, it does not postulate the impact on maintenance costs of any improved reconfigurability between missions brought about by the DAIS design.

PREFACE

This report describes a preliminary investigation of the potential impact of the Digital Avionics Information System (DAIS) concept on system support requirements and life cycle cost (LCC) through an LCC comparison of a representative mid-1980s DAIS configured avionics suite and present day conventionally configured avionics suite. It is one of several products of contract F33615-75-C-5218, "DAIS Life Cycle Costing Study," which was conducted to provide tools and techniques for evaluating the LCC impact of operational implementation of the DAIS concept of avionics integration.

The conduct of the study was directed by the Advanced Systems Division, Air Force Human Resources Laboratory, Wright-Patterson Air Force Base, Ohio, and is documented under Work Unit 20510001. It was performed under Air Force Avionics Laboratory Program Element 63243F, "Digital Avionics Information System," Project 2051. Project 2051, "Impact of DAIS on Life Cycle Costs," is jointly sponsored by the Air Force Human Resources Laboratory, the Air Force Avionics Laboratory, and the Air Force Logistics Command.

Contract funds were provided by the Air Force Avionics Laboratory. The DAIS Program Manager is Mr. Terrance A. Brim. Mr. H. Anthony Baran is the Air Force Human Resources Laboratory Project Scientist. The Air Force Logistics Command Project Officer is Captain Ronald Hahn. The contractor Program Manager is Mr. John Goclowski.

TABLE OF CONTENTS

	Page
I. INTRODUCTION	9
II. DAIS CHARACTERISTICS	10
2.1 DAIS Hardware	10
2.2 DAIS and Non-DAIS Hardware	12
2.3 DAIS Software	20
2.3.1 Mission Software	20
2.3.2 Nonreal Time Support Software	21
2.4 Non-DAIS Software	23
III. LIFE CYCLE COST IMPACT MODEL (LCCIM)	24
3.1 The LCCIM Modeling System	24
3.2 The Reliability, Maintainability, and Cost Model (RMCM)	26
3.2.1 Cost Equations of the RMCM	28
3.2.2 Application of the RMCM Computer Program	30
3.2.3 RMCM Data Sources	31
3.3 Assumptions and Constraints Applied in this Study	32
IV. IMPACT OF THE DAIS CONCEPT	38
4.1 Life Cycle Cost	38
4.2 Nonrecurring Costs	40
4.2.1 Cost of Research and Development	40
4.2.2 System Investment Costs	40
4.2.3 Support Investment Costs	42
4.3 Recurring Costs	45
4.3.1 Operation Costs	45
4.3.2 Support Costs	45
4.4 Cost of System Disposal	47
4.5 Impact of Standardization	47
4.5.1 Extending the DAIS Concept across Aircraft Types	47
4.5.2 Extending the DAIS Concept across Subsystems	53
4.6 Inflation Effects	55
4.7 Effect of the DAIS Concept on Service Availability	55
V. CONCLUSIONS AND RECOMMENDATIONS	58
REFERENCES	63
BIBLIOGRAPHY	65

TABLE OF CONTENTS (continued)

	Page
ACRONYMS	71
GLOSSARY OF COST ELEMENTS	73

LIST OF FIGURES

	Page	
2.1	General DAIS Architecture	11
2.2	Architecture Comparison	13
2.3	Navigation Subsystems	14
2.4	Communications Subsystems	15
2.5	Countermeasures Subsystems	16
2.6	Air-Ground Attack Subsystems	17
2.7	Controls and Displays	18
2.8	Processing and MUX Interface	19
2.9	Nonreal Time Support Software	22
3.1	Designer Interaction with Analytic Process	25
3.2	LCCIM Modeling System Process	27
3.3	Structure of Cost Model Portion of RCMC	29
4.1	Effect of Standardization on Avionics Cost per Aircraft	32
4.2	Inflation Effects	57
5.1	Contributions to LCC by Cost Category	59
5.2	Contributions to LCC by Nonrecurring Cost Elements	60
5.3	Contributions to LCC by Recurring Cost Elements	61

LIST OF TABLES

	Page	
2.1	Non-DAIS (A-7D/E) Software Sizing	23
4.1	Overview of LCC Comparison	39
4.2	Expanded Nonrecurring Costs	41
4.3	Expanded Recurring Costs	44
4.4	Effect of Standardization on Cost Elements	49
4.5	Impact of DAIS Application to an Additional Aircraft Type	50
4.6	Impact of Learning Curve Effect	51
4.7	Cost Impact of Adding a Subsystem	54
4.8	Effect of Six Percent Inflation on LCC	56

IMPACT OF DAIS CONCEPT ON LIFE CYCLE COST

I. INTRODUCTION

The Digital Avionics Information System (DAIS) concept can serve as a basis for guiding future avionics development as digital technology continues its rapid expansion into new weapon systems and aircraft retrofit programs. DAIS can do so by providing guidelines for avionics standardization. Defining DAIS-attributable performance capabilities is the first step toward the development of a DAIS-related data base and design standardization. Yet, performance capabilities will provide only a part of the data necessary for decision making regarding the DAIS concept. An additional requirement is a realistic estimate of the life cycle cost (LCC) impact of implementing the DAIS concept which is provided by this study.

Given a scenario specifying aircraft type, aircraft mission, and aircraft support environment, the objective of this study was to make a quantitative comparison of LCC between a DAIS and a conventional avionics configuration. Along with this objective, the study was designed to achieve the following.

1. Identify those cost elements which have the greatest impact on the LCC differential between a DAIS and a conventional (non-DAIS) avionics configuration.
2. Identify and describe the effects of inflation, retrofit, standardization, and learning curve on LCC.

The Life Cycle Cost Impact Model (LCCIM), applied in this analysis, provides a systematic approach to evaluating the cost effectiveness of avionics designs. The cost effectiveness estimates were obtained by comparing the LCCIM of a DAIS and a conventional (non-DAIS) avionics configuration.

The remainder of this volume describes the DAIS LCC study as follows.

- Section II. The DAIS characteristics and the differences between a DAIS and a non-DAIS avionics configuration.
- Section III. The LCCIM modeling system used in this study and the aircraft/avionics scenario used for the DAIS/non-DAIS cost comparison.
- Section IV. The results of the DAIS/non-DAIS LCC comparison by cost category, subcategory, and element; and, the factors which impact LCC.
- Section V. The conclusions of the study and an identification of the cost elements which appear to be high cost drivers.

II. DAIS CHARACTERISTICS

To meet complex mission requirements, conventional military avionics have grown in number and sophistication. This growth has inevitably led to increased costs of design, acquisition, and support. These costs have spiralled upward due to the fact that avionics subsystems have typically been acquired as autonomous units with little, if any, commonality. Thus, successive weapon system acquisition programs have resulted in a proliferation of sophisticated, nonstandard avionics suites leading to escalating costs.

The DAIS seeks to demonstrate a solution to the problems of both proliferation and nonstandardization. It functions with a standard multiplex bus, processor, executive control software, and the use of higher order language (HOL). Basically, the DAIS technology provides: (a) the ability to modify existing software to meet new requirements, (b) the potential for improved reliability through the planned use of redundancy at subsystem, equipment, and component levels, (c) the opportunity for adding new sensors and capabilities to the system without rewiring the aircraft, and (d) the means for using modular or common equipment design on different types of aircraft. As a result, the DAIS approach offers the opportunities of enhancing capability and flexibility while minimizing LCC.

The minimum essential elements of the DAIS concept (as presently defined) include:

1. 1553B MUX Bus (with Bus Controllers and Remote Terminal Units)
2. AN/AYK-15A Processor (with associated memory)
3. Standard JOVIAL executive

Additional elements included in the DAIS configuration are integrated controls and displays, central integrated testing, and consolidated test equipment. A simplified block diagram of the general DAIS architecture that links these core elements with sensor elements is shown in Figure 2.1.

2.1 DAIS HARDWARE

The processors communicate with each other and with the sensors, weapons, controls, and displays through a bus control interface unit (BCIU) which can be contained within the processors. Communication is accomplished through a dual redundant standardized (MIL-STD-1553A) multiplex data bus system under control of the software.

The software consists of application software and executive software. Application software performs the processing required for a specific aircraft mission application and major functions (such

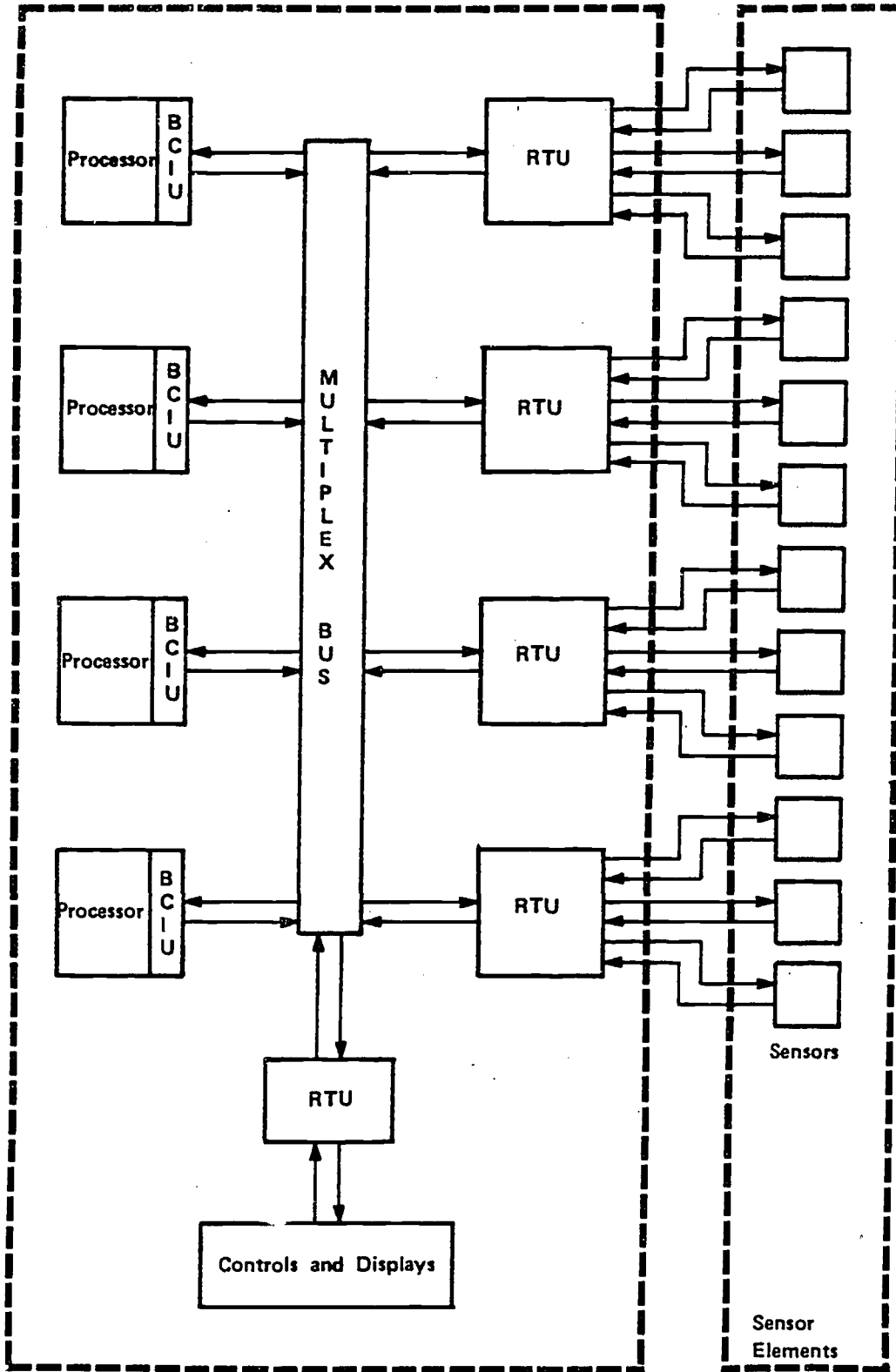

Figure 2.1 – General DAIS architecture.

as navigation, weapon delivery). Executive software performs the bus system control and provides services to the application software. The software is implemented in the JOVIAL J73/I higher order language (HOL), using structured programming techniques and standards. A modular architectural approach is used to insure reliable, transferable, and maintainable software.

The Remote Terminal Unit (RTU) conditions various analog, digital, and discrete signals from the sensors and subsystems through interface modules and formats these signals for bus transmission. The RTU is designed to accommodate various interchangeable types of interface modules to provide the proper electrical interface with different sensors. The RTU is programmable to permit mapping of the data between the data bus and the sensors, as required for the specific avionic system configuration. The avionic sensors or subsystems can also interface directly with the data bus if the subsystem is compatible with the bus control protocol.

Controls and displays within the aircraft provide an interface between the operator and the avionics system configuration. They consist of a set of data entry devices and display devices using digital input/output capability whenever feasible. The controls and displays also provide redundancy where displays or integrated keyboards can serve as a backup to each other.

2.2 DAIS AND NON-DAIS HARDWARE

The discrete and nonintegrated quality of the non-DAIS concept becomes apparent when the DAIS and non-DAIS architecture are compared in terms of functional groups to be discussed in hierarchical levels (see Figure 2.2). The upper portion of this figure presents the functional subsystem groups normally found in a non-DAIS configuration. Each of the subsystems contained in these highest level groups usually contains their own power supplies, controls, displays, wiring, and software. To illustrate the basic structural difference, these functional groups are then separated into the basic DAIS structure of sensors and core. In the figure, the functional group of processing and multiplex (MUX) interface (characteristic of DAIS) is added under "core."

The DAIS and non-DAIS hardware elements selected for this study can best be visualized by extending the functional groups identified in Figure 2.2 to two lower levels of indenture. The extension is accomplished, as shown in Figure 2.3 through 2.7, for the two configurations compared in this LCC study. Equipment elements are annotated as to their applicability to DAIS, non-DAIS, or both. Figure 2.8 depicts the equipment elements peculiar to the DAIS processing and MUX interface functional group.

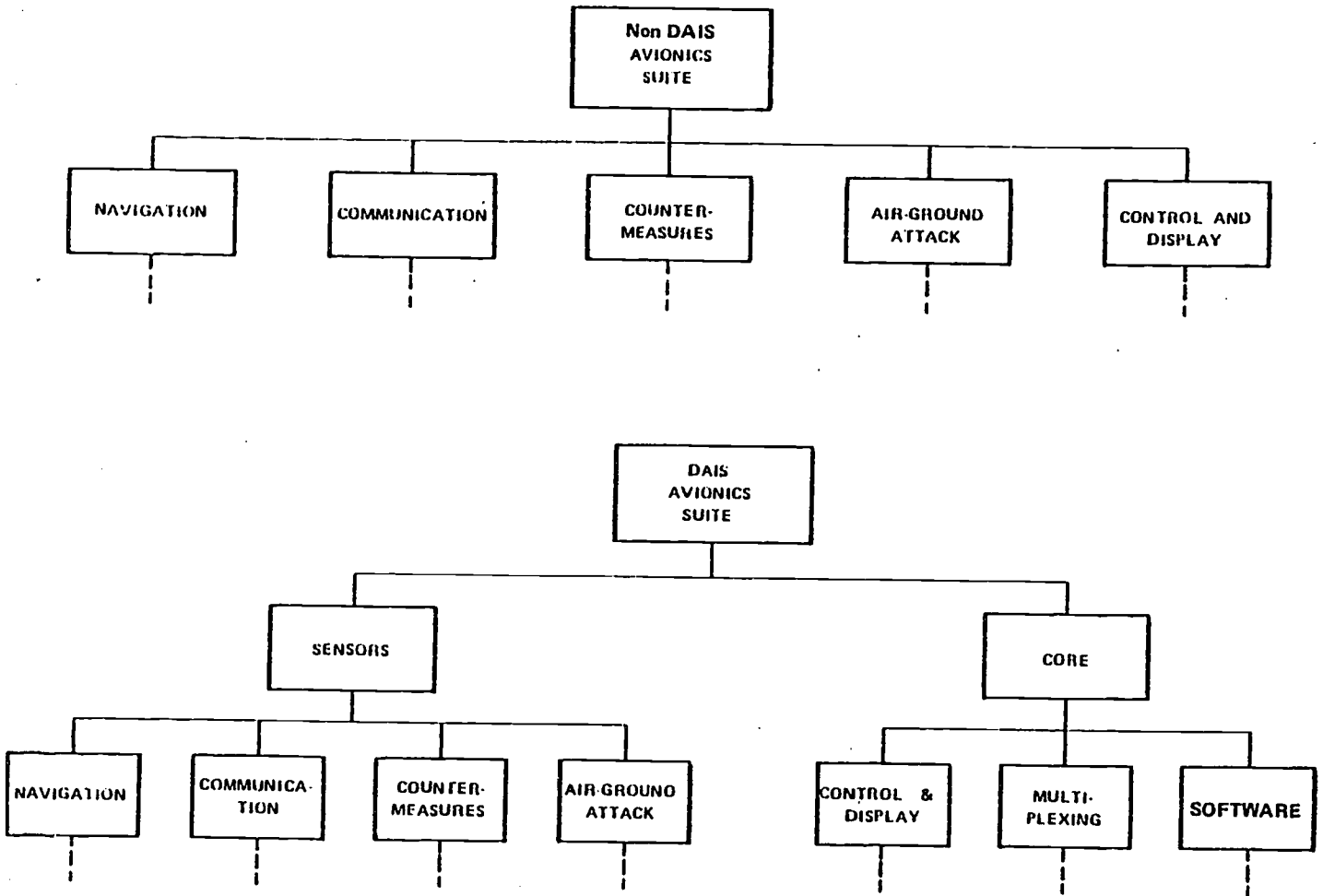
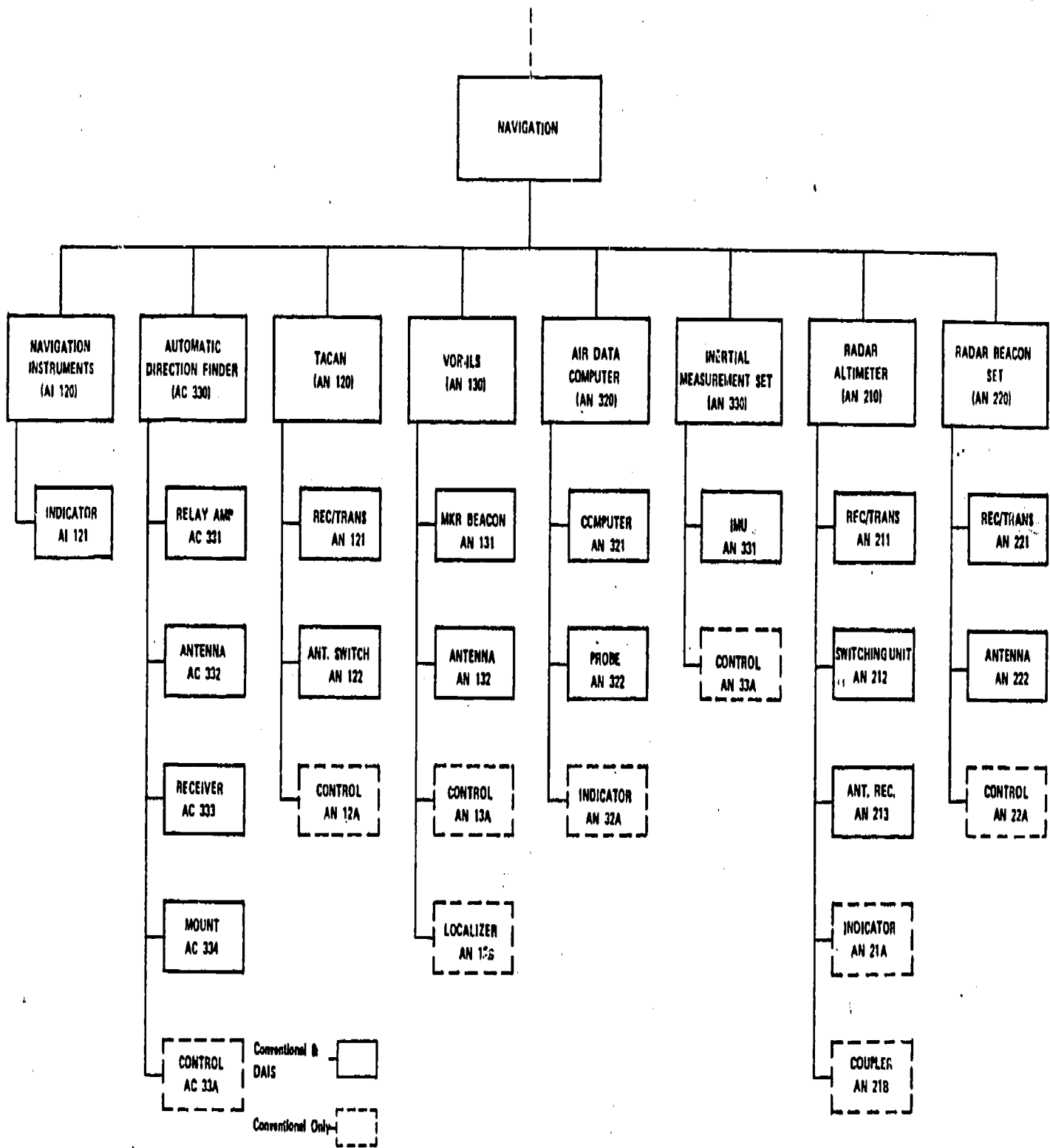

Figure 2.2 – Architecture comparison.



17

Figure 2.3 -- Navigation subsystems.

18

17

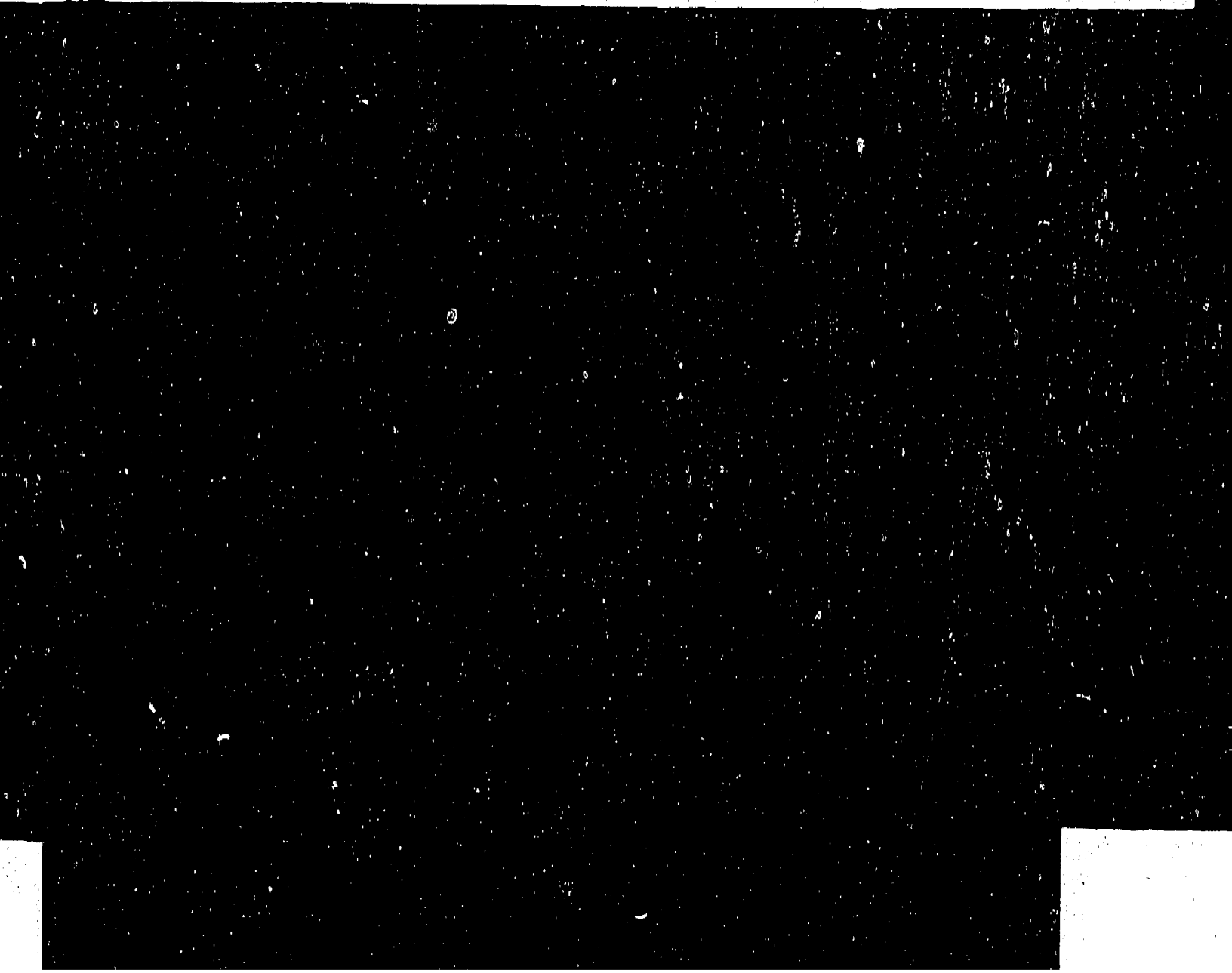

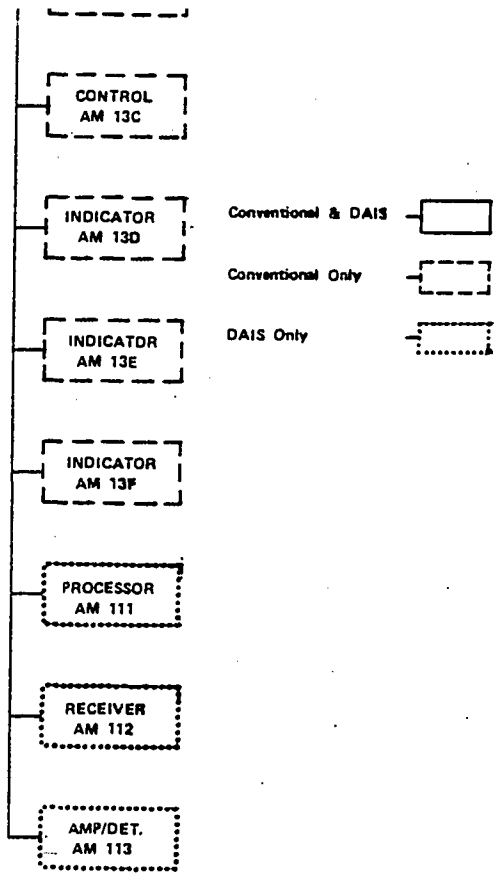

Figure 2.5 – Countermeasures subsystems.

21

16

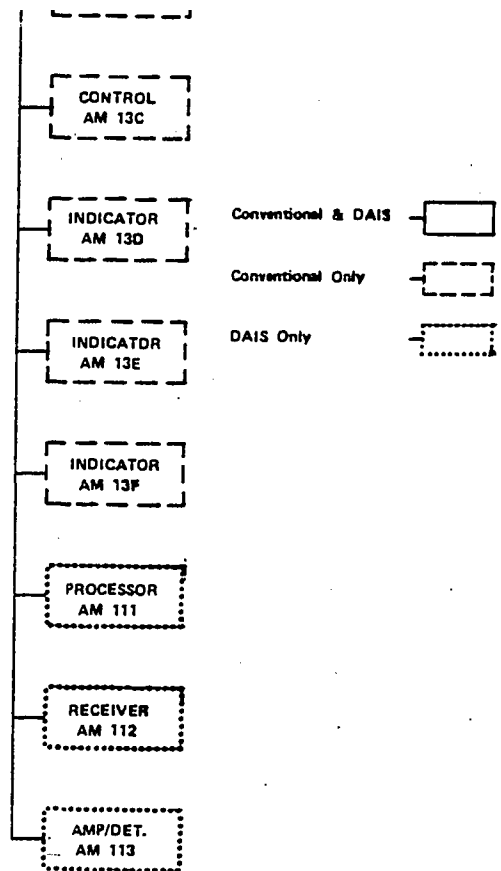

Figure 2.5 – Countermeasures subsystems.

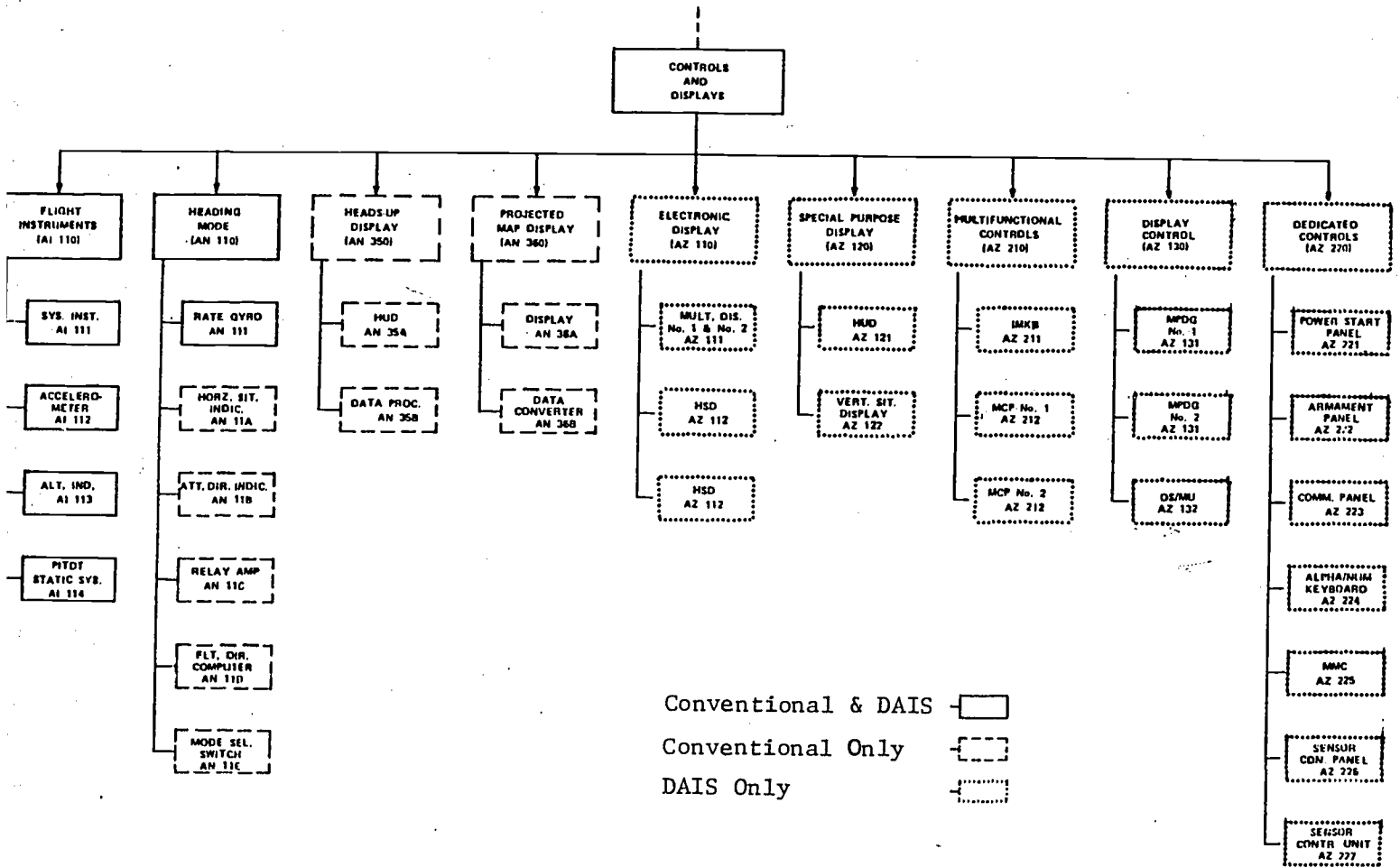

Figure 2.7 -- Controls and displays.

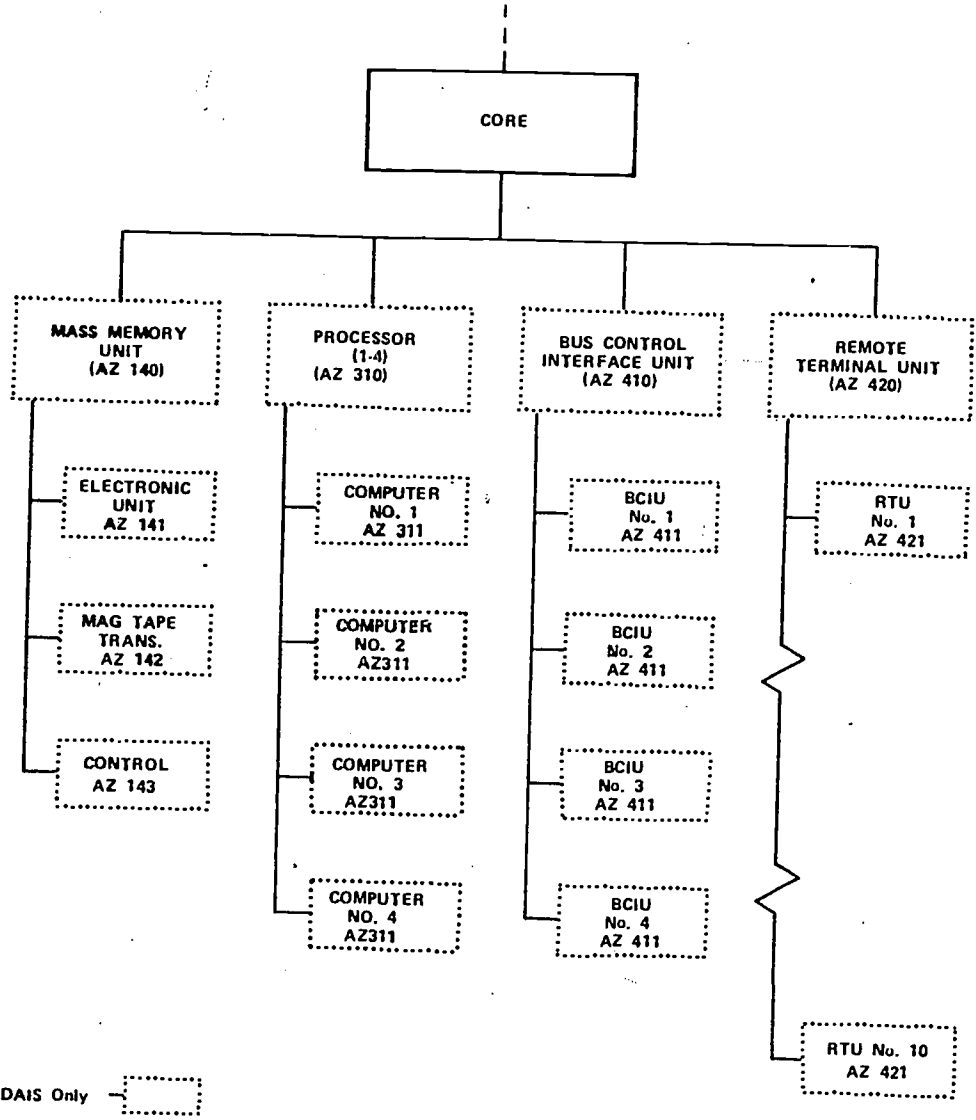

Figure 2.8 - Processing and MUX interface.

2.3 DAIS SOFTWARE

The DAIS software configuration consists of mission software and a set of nonreal time support software. Each is explained in the following subsections.

2.3.1 Mission Software

Mission software consists of the operational flight program (OFP) and the operational test program (OTP). The OTP provides readiness testing on the flightline to insure that the processors, the MUX bus, and the sensors are functioning properly. The cost estimating relationships (described in Section 5.1.3.5 in the supplement to this volume) treat software investment as system-level integration of off-the-shelf packages. Software support (described in Section 5.2.2.7 in the supplement) covers maintenance (correction of deficiencies) but no enhancement modifications.

The OFP is divided into executive software and applications software. The OFP executive software consists of a single master executive and a local executive in each processor. These executive routines provide system services used by the applications software. In the DAIS architecture, the executive software has been allocated functions concerning system state bookkeeping and communications. Aspects of the OFP that are mission and configuration dependent are implemented in the applications software.

DAIS executive tables are specialized for a particular mission through the use of the Partitioning, Analyzing, and Link Editing Facility (PALEFAC) support software. The PALEFAC extracts the information from statements in the applications software. Thus, if a DAIS were to be implemented for a mid-1980s close-air-support (CAS) aircraft, the mission software development effort could focus on the applications software requirements. It would not be necessary to redevelop the executive requirements. In fact, the DAIS executive is already under study for potential application in current aircraft design efforts.

The DAIS OFP application software architecture is a partitioning of functions that integrate the aircraft sensors, controls, and displays with mission-related tasks. Application software elements are:

System Control Modules

Six modules responsible for initializing and controlling the applications software.

1. Master Sequencer - Initiates other control modules.
2. Configurator - Controls operations of other programs.

3. Request Processor - Interprets pilot inputs from the panel MMP, IMFK, and MFK.
4. Subsystem Status Monitor - Monitors status of equipment.
5. IMFK Handler
6. MFK Handler

Operational Sequencers (OPS)

Responsible for operational status of each independent mission phase (such as pre-flight, takeoff/climb, and weapon delivery).

Specialist Functions (SPEC)

Supporting functions required by an OPS or by the pilot. Brute Force SPECS provide pilot control over operations not available in the current OPS. Computational SPECS perform utility computations required throughout most mission phases.

Equipment Processes (EQUIPs)

Interface between software, sensors, and controls. EQUIPs provide the specifics of equipment communication and isolate the effects of changes in equipment with the same function.

Display Processes (DISPs)

Control cockpit displays.

2.3.2 Nonreal Time Support Software

Figure 2.9 provides an overview of nonreal time software facilities. The most important software elements in these facilities are the JOVIAL compiler, the Software Design and Verification System (SDVS), and the PALEFAC. Because the JOVIAL J73/I higher order language has become a USAF standard, the DAIS JOVIAL compiler should find wide application in USAF software development. The SDVS is a generalized facility which could be applied to development and maintenance of any OFP. The PALEFAC provides an automated means of generating bus control and executive data tables. It may be considered an integral part of the DAIS mission software executive. All support software, both nonreal time and real-time has been written in higher order languages (primarily JOVIAL and FORTRAN) and are constructed to be portable or capable of being hosted on another computer system. It should be noted that support software and facilities are a requirement for maintenance of any OFP, whether or not they are acquired during the development phase.

Language Translation Facilities

- JOVIAL Compiler (HBC or DEC-10)
- FORTRAN Compiler
- DEC-10 Assembler
- HBC Assembler

File Management Facilities

- Data Base Management
 - Source Code
 - Object Code
 - Test Data
 - Scenario
- Library Management
- Configuration Management
 - Status Accounting
 - Version Control
 - Change Control

Simulation Facilities

- Interpretive Computer Simulation
- Statement Level Simulation
- Data Bus Simulation
- Environment Simulation
- MS Function Simulation

Load Module Preparation Facilities

- Linkage Editor
- Loader
- MS Partitioning Support
 - Bus Traffic Analysis
 - Real-Time Usage
 - Core Allocation

Man Machine Interface Facilities

- SDVS Control Language Processor
- Simulation Control/Sequencing
- Output Preparation

Figure 2.9 - Nonreal time support software.

2.4 NON-DAIS SOFTWARE

The parameters describing the software requirements for a current non-DAIS configuration were taken from the A-7D/E navigation and weapon delivery system. Table 2.1 shows the size of the software package. This package was chosen as representative of current non-DAIS software in that:

1. It is monolithic as opposed to modular for DAIS;
2. Each function is performed by sections of coding occurring throughout the program making enhancement or modification difficult;
3. A larger percentage of memory is used (99.5 percent non-DAIS versus 63 percent DAIS); and,
4. The configuration and mission is similar to that defined for the mid-1980s DAIS design. (The software satisfies the same general set of requirements but has fewer specific functions due to a different architecture of partitioning.)

Table 2.1 - Non-DAIS (A-7D/E) Software Sizing.

<u>Function</u>	<u>Memory (16 bit words)</u>		
	<u>Instruction</u>	<u>Data</u>	<u>Total</u>
Navigation (1)	3440	570	4010
Weapon Delivery (1)	3690	520	4210
Radar Processing (1)	490		490
System Overhead	3710	510	4220
Modifications (including PAVE PENNY)			<u>3000</u>
			15930

(1) includes display processing functions.

III. LIFE CYCLE COST IMPACT MODEL (LCCIM)*

An LCC impact modeling system was developed within the DAIS LCC study specifically for use in the comparison of system design/support alternatives. The impact analysis of a concept such as the DAIS (as opposed to a specific piece of hardware/software) requires a capability for extended visibility into the operation and support environment in which it will be used. This demands an analytic procedure which considers the interactions and constraints of the concept and its application. The LCCIM presents such a procedure by combining both separate models and a methodology for their use and data support.

Existing LCC tools fall short in terms of their ability to approach the assessment of LCC in a comprehensive and systematic way which leads a user from a specification of design/support conditions to the cost impact requirements they generate. Almost all LCC models (including the LCCIM), apply cost factors to given resource utilization estimates, calculate the expected values of cost elements, and aggregate those elements to produce an estimate of LCC. The LCCIM however, exceeds these capabilities by incorporating a unique methodology for system operation and support (O&S) requirements estimation which makes its LCC results more a product of analysis than of estimation. This is an important feature because, while existent LCC models depend on input estimates, the LCCIM can analytically generate the input requirements of a number of cost assessment components.

3.1 THE LCCIM MODELING SYSTEM

The approach taken with the LCCIM was to include analytic techniques and procedures in the system which are needed to accomplish the modeling system objectives. The highest level objective of the modeling system (as depicted in Figure 3.1) is for the designer, or manager, to use the LCCIM to make cost and requirements impact estimates the basis for selecting between alternatives which influence system design, manpower, and logistics characteristics. That overall objective function can be stated as follows: minimize LCC subject to the specified constraint on equipment availability, given that the equipment satisfies performance requirements of the selected operational and logistic scenarios. The iterative use of this objective function in closing the loop in Figure 3.1 will cause the weapon system characteristics to converge to their most cost-effective values. In this study,

*This section provides a brief discussion of the LCCIM as it applies to this study. For a more complete detailed description of the LCCIM, refer to other available reports [1,4]. (Note that numbers enclosed in square brackets indicate references listed at the end of this report.)

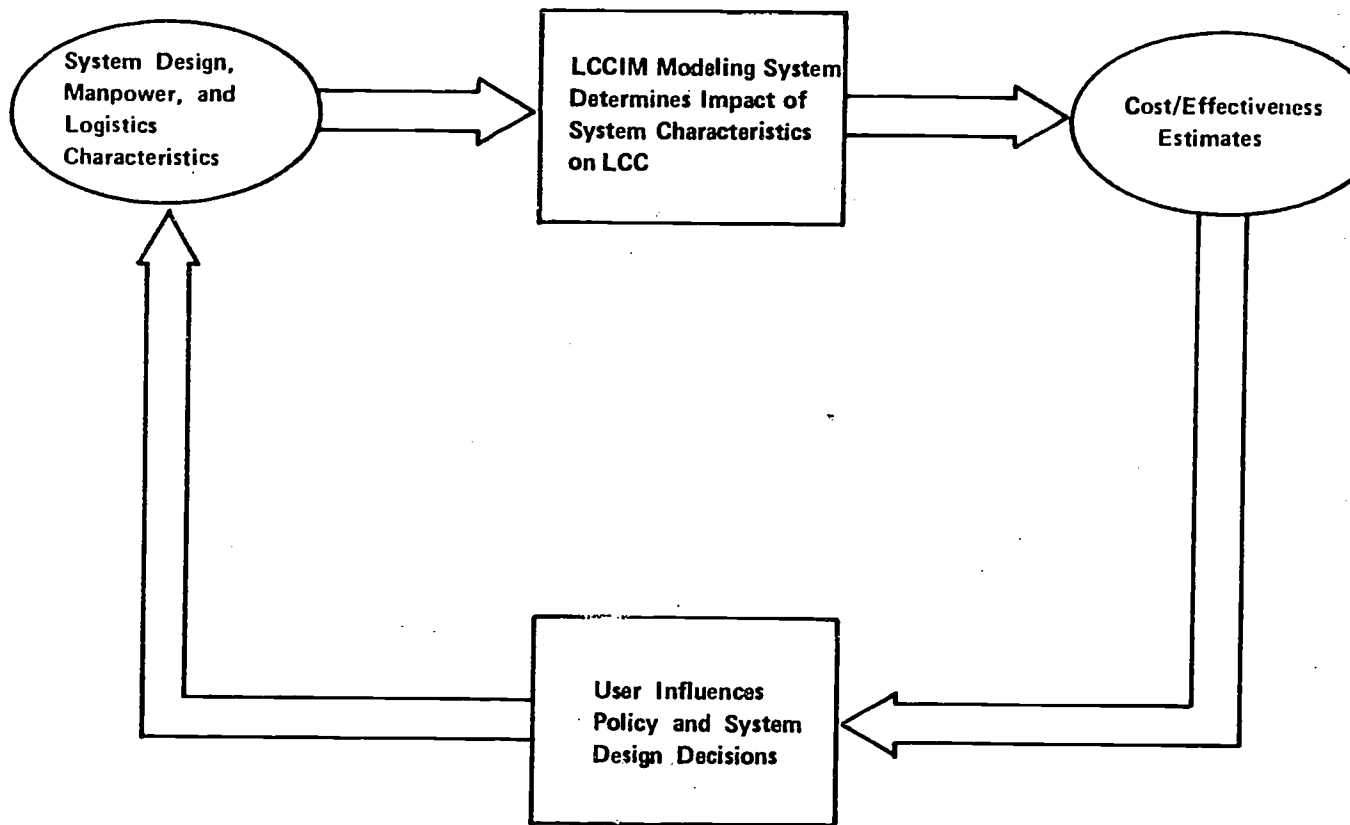

Figure 3.1 – Designer interaction with analytic process.

the modeling system was used to make a comparative analysis of a DAIS versus a conventional configured aircraft weapon system, each of which are described in Section II.

The analytic techniques, procedures, and models which constitute the LCCIM modeling system are shown in Figure 3.2. This application of the LCCIM involved a functional analysis and a maintenance analysis (refer to Figure 3.2). The functional analysis identified a baseline set of equipment which functionally satisfied CAS mission requirements by employing a combination of existing equipment and new DAIS technologies. Comparable equipment currently existing in the DoD inventory was selected as the non-DAIS reference for the DAIS baseline set of equipment. Operational and logistic scenarios to be used in the analyses were also defined to complete the set of given conditions for exercising the LCCIM.

The maintenance analysis determined how reference values for resource utilization parameters must be modified to reflect design, manpower, and logistics concept changes. It depicted the sequences of maintenance events in action networks which incorporated average values for the probability of occurrence and the resource utilization associated with each event. Resource utilization parameters included skill category, skill level, crew size, event duration, and support equipment required for each event. To generate DAIS baseline values for parameters in the maintenance networks, actual field data on the non-DAIS reference equipment was collected and modified to reflect the effect of DAIS design differences. In addition to accounting for design differences, network parameters were modified to reflect anticipated changes in maintenance, manpower, training, and technical documentation concepts resulting from the DAIS design.

The computerized portion of the LCCIM process is comprised of three separate models:

- Reliability and Maintainability Model
- Cost Model
- Training Requirements Analysis Model (TRAMOD)

Briefly, the TRAMOD was used to determine a baseline training program based on skill and knowledge requirements. The combined Reliability, Maintainability, and Cost Model (RMCM) aggregated resource utilization and applied cost factors to all cost elements so that comparable LCC estimates could be generated for each alternative configuration.

3.2 THE RELIABILITY, MAINTAINABILITY, AND COST MODEL (RMCM)

The RMCM portion of the LCCIM is a computer program which functions in an interactive mode, supplemented with a batch print capability. It operates in conjunction with a data bank containing

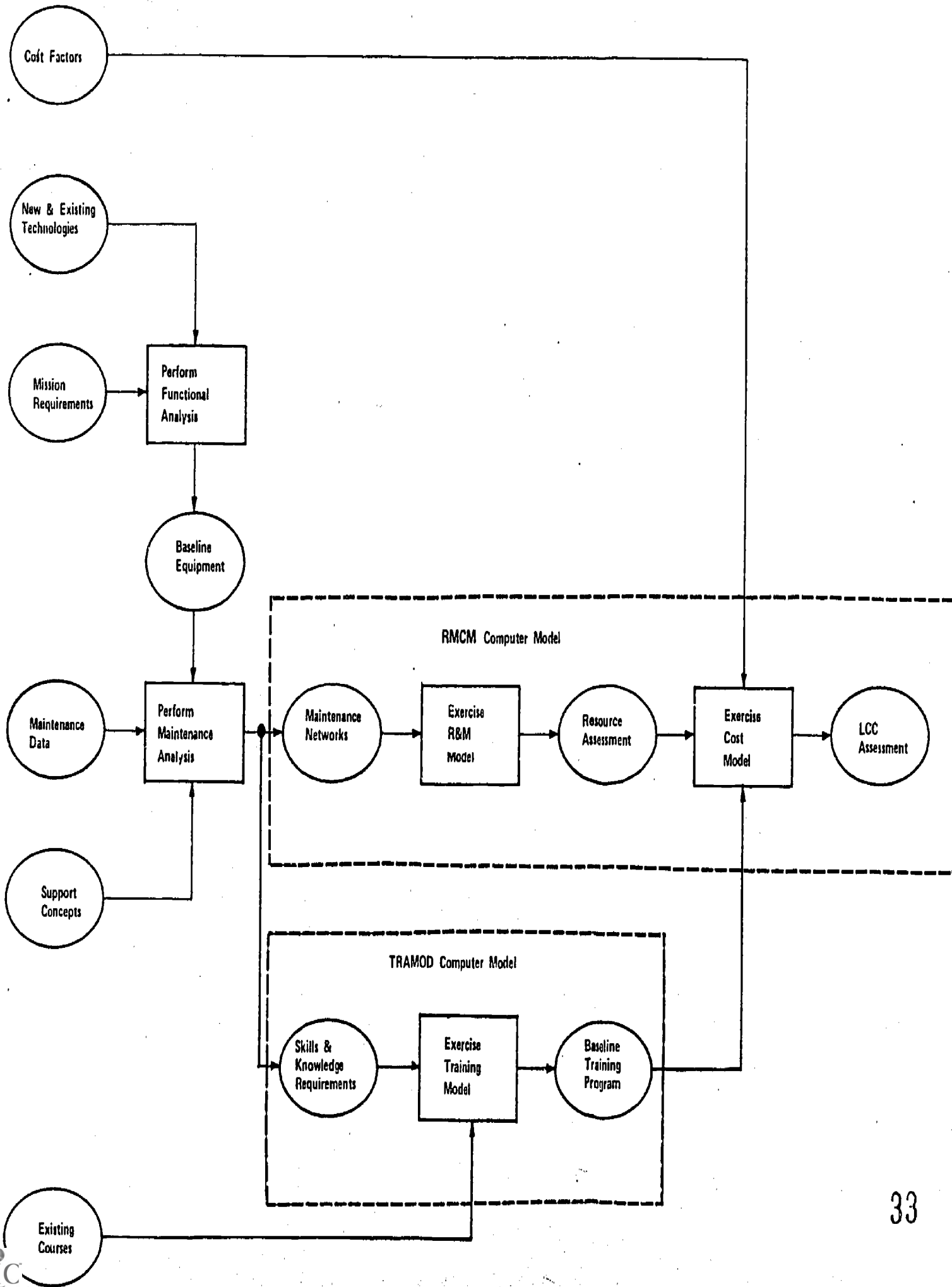

Figure 3.2 -- LCCIM modeling system process.

historical reliability and maintenance data gathered from operational systems. This data is made relevant to new systems by factoring historical data on the basis of the functional and maintenance analyses. Inputs to the RMCM include the frequency of maintenance actions by subsystem and line replaceable unit (LRU) for both aircraft and support equipment (SE); and data concerning the task events within each maintenance action (such as type, probability of occurrence, average time to complete, manpower type and skill requirements, and SE requirements). The model uses these inputs to compute the manhour resources and spares used to satisfy the maintenance requirements of each subsystem and its LRUs for both flightline and shop actions. The Cost Model portion of the RMCM is an analytical accounting cost model which computes the LCC of a proposed system in this structured and systematic way.

Within this study, the RMCM aggregated resource utilization depicted in the R&M networks by LRU, subsystem, and system for use as input to the cost equations. It also identified high resource drivers and measured effectiveness in terms of equipment availability. Using existing courses as references, skill, and knowledge requirements for each maintenance event were simultaneously evaluated through the Training Requirements Analysis Model (TRAMOD), for the purpose of generating baseline training program data (such as course length and course cost) for use by the RMCM. Detailed cost factors were applied to resources utilized and to the training programs. More general factors were applied to all other cost elements to compare the two avionics configurations using total LCC estimates. (The batch print outputs used in this LCC comparison study are contained in Sections I and II of the supplement of this report.)

3.2.1 Cost Equations of the RMCM

The DAIS LCC analysis covers all five major life cycle phases of a weapon system: conceptual, validation, full-scale development, production, and deployment. When applicable, a sixth phase (disposal) can be included in the life cycle but was not relevant to this study. All research and development takes place during the first three phases (conceptual, validation, and full-scale development). System and support investment costs occur during the production phase. The recurring operating and support costs are incurred during the deployment phase. With this in mind, a hierarchical structure was chosen to catalog the principal cost categories, subcategories, and elements associated with these phases that constitute total LCC of a weapon system (refer to Figure 3.3).

The cost element structure of the Cost Model portion of the RMCM and its associated data base were designed to simplify and expedite the identification of system cost drivers. (For example, nonrecurring cost elements have been isolated from recurring cost elements, so that the LCC impact of each can be clearly identified.)

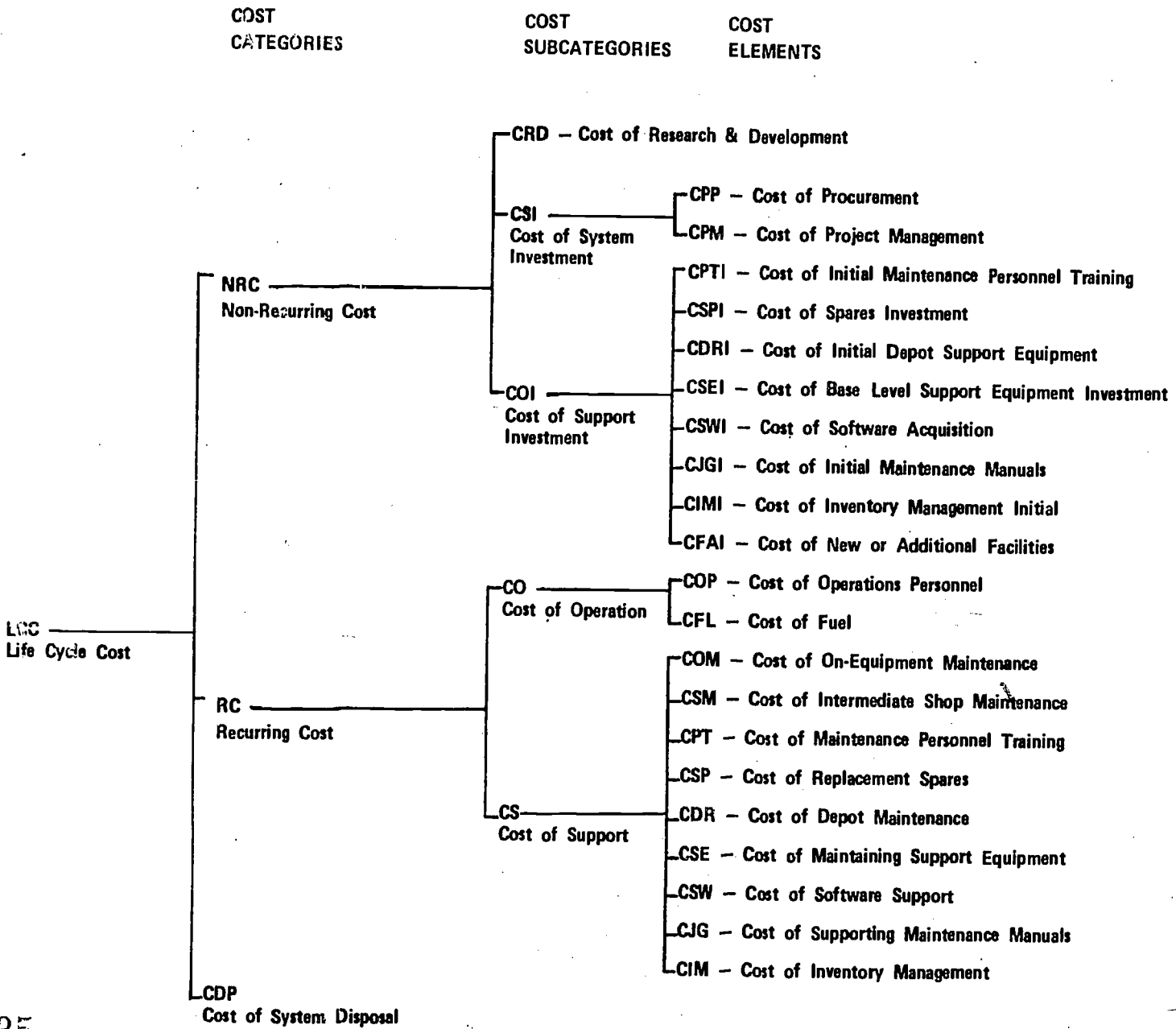

Figure 3.3 -- Structure of cost model portion of RMC.

The principal cost categories with their subcategories are:

<u>Cost Category</u>	<u>Subcategory</u>
Nonrecurring Costs	Cost of research and development (R&D), system investment cost, and support investment cost (the initial one-time development and investment costs).
Recurring Costs	Annual operation and support costs.
Final Disposal Costs	Gains or losses from disposal

The cost subcategories consist of cost elements. The Cost Model addresses 23 elements reflecting the development, production, operation, and support costs. The cost equations contained in the Cost Model are adaptations of the Air Force Logistics Command's Logistics Support Cost Model (using similar cost term definitions). An explanation of the individual cost elements, including the equations used to compute the elements, is presented in Section V of the supplement to this volume.

3.2.2 Application of the RMCM Computer Program

Given a data base for a specific equipment configuration, the interactive RMCM program can perform the following types of analysis and functions.

R&M Computation	Determines resource utilization. R&M input values can be adjusted (perturbed) for trade-off analysis and sensitivity investigations.
Cost Computations	Applies cost factors to the results to determine LCC.
R&M Perturbation	The user may change the values of any of the R&M input variables and/or any results from the R&M computations performed by the RMCM.
Cost Perturbation	The user may change the values of any of the cost input variables. These perturbations of the R, M, or cost parameters can be accomplished through either (1) percentage factor, (2) a bias (+ value), or a replacement value.
Output Generation	RMCM output data required for the user's specific needs are presented simultaneously and are directly comparable using the interactive routine.

Also, generated cost output is stored in a special file and may be identified for use in generating processed data reports through the RMCM batch program. The following such reports are available.*

Output Report Number	Title
1	System Cost
2	Expanded Nonrecurring Costs
3	Expanded Recurring Costs
4	Costs by Subsystem Contributions
5	Costs by LRU Contributions
6	Reliability, Maintainability, and Availability by Subsystem
7	Manhour Costs per Year by AFSCs and Subsystem Supported
8a	Spares Requirement - Investment
8b	Spares Requirement - Replacement
9	Support Equipment Requirements/Cost
10	Cost of Training

3.2.3 RMCM Data Sources

When applying the RMCM, the accuracy of the estimate will depend on the source of data. In actual applications, such as this study, the user can expect the estimate to increase in accuracy for a specific system as input data matures from theoretical data to actual field data. The structure of the RMCM facilitates the interactive changing of input data, data updating, and output data iteration. This capability allows LCCIM to be applied continually throughout acquisition up to and including the deployment phase. Due to the speed with which alternatives can be considered and their impact on LCC can be estimated, this capability also expedites the evaluation of trade-offs within a specific configuration.

The RMCM requires a data base that contains two data banks. One data bank is for the R&M parameter data. The other is for the cost parameter data. The information needed to prepare these data banks can be found in the R&M Model Users Guide [3], and the RMCM Users Guide [1].

Four data banks files, two for cost data and two for R&M data were developed for this comparison study. One pair provides cost and R&M data for a conventional baseline CAS avionics conceptual

*A complete set of these output reports, for the conventional and the DAIS avionics configuration, is provided in Sections I and II of the supplement to this volume. The RMCM results of the subject analysis are summarized in Section IV.

design configuration. The second pair provides data for a mid-1980s DAIS CAS avionics conceptual configuration (the RMCM computer program, time frame, and equipment configuration). For a new weapon system, scenario-related information of this type can usually be found in the required operational capability (ROC) document during the conceptual phase of system development. For this study, the following scenario was selected as a common basis for comparing the two avionics configurations.

- A. System Mission
 - CAS functions
 - 1 wing, 72 aircraft
 - 1 base located within CONUS
 - 30/60 (peacetime/contingency) flying hours per aircraft per month
- B. System Design
 - All subsystems completely designed (R&D cost includes only the system-level integration)
 - An instantaneous acquisition (off the shelf)
 - Life cycle of 15 years (planned inventory usage period)
 - No further inherent reliability growth to be expected

3.3 ASSUMPTIONS AND CONSTRAINTS APPLIED IN THIS STUDY

The maintenance and support policy for any avionics configuration must consider the integrated resource requirements for training, maintenance manuals, spares, manpower, and SE which support the avionics equipment to be used. The complex interrelationships program was exercised separately for each pair of data files to compare the two avionics configurations. These data bank files consist of three basic data value types.

1. Standard values
2. Estimated values based on historical comparisons or estimating relationships
3. Scenario constant values

References for each source of the above RMCM data are provided, by data element values, in the appendix of [1] and are discussed in the following paragraphs. Some of these values are repeated for pertinent data in Section V (and in Section V of the supplement) in support of the explanation of cost equations.

Standard values were obtained from government sources. They are usually developed by government agencies from historical cost-accounting information or special studies. Examples of the sources used in the data collection for this study are given below. They consist of government documents and approved models.

AFR 173-10
AFM 26-3

AFRP 177-1
ATC/ACM
RAND Reports
Logistics Composite Model (LCOM)
AFLC Logistic Support Cost (LSC) Model

Estimated values are historical estimate comparison data derived from the actual or comparable weapon system experience. Examples of sources used to obtain historical estimate comparison data for this study are:

AFM66-1, KO51-PN8C
LCOM Extended II Data
(obtained from base level tapes of AFM 66-1 data)
A-7D Manpower Source Listing
Uniform Airmen Records
Technical Training School Course Charts
Design/Logistics Support Data-National Stock Catalog
Contractor Furnished Data

When required historical estimate comparison data is unavailable, specially developed cost estimating relationships based on historical experience are developed. This was required in two cases for this study: (a) to compute the cost of maintenance manuals, and (b) to estimate the cost of software development and upkeep.

Scenario constants are input values established from the operational, environmental, and equipment standards determined by the conditions of weapon system deployment. These relate to considerations such as the number of sites, number of aircraft per site, flying hour between these maintenance and support resource areas, as well as their impact on cost, are manifested through R&M characteristics of the equipment.

The R&M characteristics are measured by such parameters as: mean time between failure, average time to perform the repair tasks, probability of occurrence of each task event, number of technicians required per task, SE utilized, repair requirements of SE, and spares needed for the concept postulated. Changes in these R&M parameters brought about by maintenance and/or support requirements are determined, in part, through an understanding of the following man/machine interrelationships.

1. Functional performance of the subsystems of the avionics configuration.
2. The complexity of the subsystem electronics or mechanics.
3. The quantity and complexity of LRUs within the subsystem.
4. The availability and capability of manpower.

5. The maintenance aids requirements of the individual units and the technicians who use them.

Current avionics equipment, with its digital integrated circuitry, is more difficult to repair at the component level in the shop. This is due to the technical skills and the sophisticated testing and repairing equipments required. Therefore, it is intended that subsystem repair be achieved on the flightline through LRU removal and replacement actions and in the shop through modular SRU removal and replacement actions. Module repair will be performed by the depot or factory and module fault isolation will be performed in the shop with the aid of the automatic or semiautomatic test stations for the DAIS avionics. These capabilities, however, are independent of the DAIS concept and, in many cases, are inherent in present day maintenance philosophy. The basic equipment R&M parameter values obtained from field data are assumed to reflect this approach.

Decisions regarding changes in the maintenance parameters had to be based on actual conditions (such as those exhibited by present subsystems of comparable design) while maintaining other parameters constant. The LCCIM is able to represent these real world conditions from which the data was obtained and yet isolate other parameters. However, certain assumptions and constraints inherent in the RCM program do affect the results of this study and must be considered in their analysis.

- A. The model considers a uniform level of system (aircraft) activity (such as flying hours) at each operating base.
- B. The spares stock level and pipeline quantities are computed to support the peak level of system activity (such as the peak base flying hours (PBPH), rather than any incremental buildup).
- C. The cost model computes all logistics support costs associated with the weapon system, subsystem, and LRU indenture level.
- D. Three levels of repairs (exclusive of condemnation) are considered: (1) on-equipment repair at base level, (2) repair at the intermediate maintenance activity (IMA) on site, and (3) repair at the depot.
- E. Air bases are assumed to be identical with respect to maintenance manpower requirements, consumables, and facilities.
- F. Air base sites are assumed to be identical with respect to logistics support and possible environmental effects on equipment failure rates.
- G. Any number of base-level repair locations or depot repair sites are allowed. However, the recurring depot repair cost factors are predicated on average values for a single centralized depot repair location.

- H. Inventories of spare LRUs are assumed to be located at each of the bases, consistent with the demand rate for LRUs at the bases and the variable depot-to-site resupply time interval.
- I. A representative transportation cost average for overseas and for CONUS sites is employed for the LRU depot repairs.
- J. The relationship established for determining the required quantities of shop SE assumes the mean SE usage times as being equal to the mean time to repair.
- K. Maintenance personnel at the various bases require the same types of skill and consequently need the same training. (This assumption is not germane to this study because only one base was used when evaluating each of the two aircraft configurations compared.)
- L. The contractor trains an initial Air Force cadre who in turn trains all maintenance personnel. Initial training is considered to be completed in or before the first year of system operation. Recurring training costs for organizational and IMA personnel are based on average turnover rates for each AFSC.
- M. Software maintenance is performed only at depot level, whereby a focal point for all software maintenance is assumed for the entire DAIS or non-DAIS configurations (even if each subsystem should have a different HOL).
- N. There are no special provisions for computing the costs of nonmaintenance support personnel and their support facilities (such as barracks, heat, and food), although they can be input as a single term.
- O. All cost data are in constant-year dollars. However, there is an option available which modifies recurring cost outputs as a function of average inflation rate.
- P. The reliability parameter values in the data bases are based on mean flight-hours between maintenance action (MFHBMA). These maintenance actions include: (a) cannot duplicate discrepancy (CND) actions both for on-equipment and in-shop LRUs removed to the shop for repair; (b) minor maintenance actions performed on the flightline; and, (c) remove-and-replace LRU actions that are followed by repair in the shop or at a depot. (See Section VI in the supplement to this volume for a further discussion of these variables.)
- Q. On-equipment and shop maintenance costs are computed to include the costs of labor for only corrective (unscheduled) maintenance at the base level. No preventive (scheduled) maintenance is included. All pre-flight and post-flight actions are considered to be performed by the operating crew.

- R. Maintenance labor costs at the depot are contained in the average cost per depot repair of an LRU.
- S. The DAIS design, when compared to the non-DAIS design, incorporates increased use of digital circuits, electronics integration on a larger scale, and an increase in modular standardization. This would allow the maintenance concept to be modified accordingly. For instance, on-equipment SRU repair and an associated two-level maintenance concept (organizational to depot) could be attempted. For this study, however, only the basic on-board test capability of the DAIS was considered.

The main technical features of the DAIS suite are the integration of sensor controls and displays, and the central processing of sensor outputs through the multiplex bus. This structure permits the use of an on-board central integrated test system (CITS) for monitoring sensor degradation and/or failure. The CITS combines the individual subsystem Built-In-Test Equipment (BITE) outputs with additional diagnostic tests on a time-shared basis and displays the various subsystem operating conditions. Malfunctions to the LRU level will be presented, thereby aiding flightline maintenance by improving troubleshooting decisions. This includes decreasing the number of cannot duplicate discrepancy reports and the number of removals that become shop retest okays.

- T. The implementation of DAIS will be attended by an upgrading of support equipment. Many of the current individual special test sets and general purpose test equipments will be integrated into single test stations for one or more subsystems. Usually these test stations will be automated to some degree, reducing the complexity of the man/machine interface. Even in the manual test stations, personnel requirements will be reduced by use of permanent interconnections and switch matrices for initiating various functional tests. Six shop test stations, similar to those used for F-15 avionics testing, have been assumed for DAIS.
- U. One of the current Air Force concerns regarding manpower is that overall reading level capability is decreasing although motivation remains high among recent recruits. Since technical orders (or maintenance manuals) are an important and necessary aid to avionics maintenance, the following guidelines were established regarding manual content and use. The existing conventional type of technical manuals will be replaced by proceduralized job guides for use with the mid-1980s DAIS conceptual application because of: (a) the growing trend toward job guide utilization as a standard practice in the mid-1980s, and (b) the standardization and modularity aspects of the DAIS concept which will provide a maintenance environment highly conducive to the implementation of the proceduralized aids;

for example, reductions in maintenance complexity (remove and replace versus repair) and in personnel skill requirements because of improved diagnostic equipment.

- V. Existing training courses were used as a baseline for both non-DAIS and DAIS maintenance technicians. Course material was matched to the tasks to be performed. Curricula were revised to complement the proceduralized aid for technicians maintaining the DAIS avionics. Discussions of the reasons for recommending revised training curricula are presented in the Training Model Technical Report [2].

Additional specific assumptions and their justifications are presented in the relevant cost element discussion in Section IV of this report and in Section V of the supplement to this report.

IV. IMPACT OF THE DAIS CONCEPT

This section will discuss the impact of the DAIS concept on LCC. It will provide:

1. A summary of the RMCM output for the DAIS and non-DAIS configurations. (The actual RMCM outputs for DAIS and non-DAIS may be found in Sections I and II, respectively, in the supplement to this report.)
2. A brief description of the cost categories, subcategories, and elements involved in the LCC computation. Each description will be confined to a definition of the term and percentage of cost decrease/increase attributable to the DAIS. (Detailed descriptions of each cost term including LCC equations, sources of data, and special considerations may be found in Section V of the supplement to this report.)
3. A discussion of four influences on LCC (standardization and retrofit, inflation, and learning curve effect) which should be considered when making any LCC comparison.

4.1 LIFE CYCLE COST

To assess the impact of the DAIS concept, LCC was calculated for a mid-1980s DAIS and a non-DAIS avionics configuration appropriate for a CAS mission. Calculations are based on 72 aircraft at one base flying 25,920 hours annually over a 15-year period. The specific assumptions and guidelines relative to this calculation were detailed earlier in this report (Section 3.3).

Table 4.1 presents an overview of the LCC comparison of the DAIS and non-DAIS avionics configurations. Cost and percentage of LCC are displayed for each cost subcategory. Cost differences and percent differences between DAIS and non-DAIS (with non-DAIS as the reference) are also shown. The percent difference was computed using the equation:

$$\% \text{ difference} = \frac{(\text{non-DAIS}) - (\text{DAIS})}{(\text{non-DAIS})}$$

The Cost of Disposal category and Operation Costs subcategory have been set to zero for purposes of simplification (to be discussed later in this section).

At the total LCC level, it is shown in Table 4.1 that the DAIS configuration has an \$11,061,000 advantage over the non-DAIS configuration for the given scenario. Furthermore, the most significant difference between DAIS and non-DAIS lies in the Support Costs subcategory where it is apparent that DAIS would cost \$33,209,000 less than the non-DAIS over a 15-year deployment period. However,

Table 4.1 -- Overview of LCC Comparison.

Category	Subcategory	Non-DAIS		DAIS		Difference	
		Cost (\$000)	% LCC	Cost (\$000)	% LCC	Cost (\$000)	% Difference
RC--Recurring							
	CS--Support	121,462	47.5%	88,254	36.1%	-33,208	-27.3 %
	CO--Operation	0	0.0%	0	0.0%	0	0.0%
NRC--Non-Recurring							
	CRD--Research & Development	5,340	2.1%	6,210	2.5%	+ 870	+16.3%
	CSI--System Investment	67,719	26.5%	90,289	36.9%	+22,570	+33.3%
	COI--Support Investment	61,060	23.9%	59,767	24.5%	- 1,293	-2.1%
CDP--Disposal							
		0	0.0%	0	0.0%	0	0.0%
	LCC--Totals	255,581	100.0%	244,520	100.0%	-11,061	-4.3%

this advantage tends to be offset by the DAIS cost increase of \$22,570,000 in the System Investment subcategory (which represents the initial buy of avionics equipment for 72 aircraft).

4.2 NONRECURRING COSTS

The Nonrecurring Costs category is defined as the one-time costs normally associated with weapon system acquisition. Table 4.2 summarizes the Nonrecurring Costs for both DAIS and non-DAIS. A \$22,147,000 advantage in favor of the non-DAIS configuration is shown. Although this difference is primarily due to the System Investment element, further differences within the Support Investment element, further differences within the Support Investment subcategory are nevertheless significant. Specifically, there are significant DAIS-related advantages in both the Initial Spares and Software Acquisition elements. However, both of these cost decreases are offset by the DAIS-related cost increases in the R&D subcategory, Field Support Equipment Acquisition and Depot Support Equipment Acquisition elements, and Maintenance Manual Acquisition.

The following subsections will describe each of the cost subcategories and elements associated with the Nonrecurring Costs category. They will also indicate the percentage increase/decrease in LCC attributable to the DAIS concept.

4.2.1 Cost of Research and Development

The R&D category includes all costs associated with the research, development, test, and evaluation of the weapon system. Specifically, this covers all system-level costs charged to a fully-developed subsystem during the validation and full scale development phases of the weapon system. It would include costs for system-level engineering design, development, fabrication, assembly, test, evaluation, and documentation. Costs are incurred in this subcategory until satisfactory completion of the initial operational test and evaluation, and the subsequent government approval for service use. The DAIS configuration estimation indicated a 16.3 percent increase (\$870,000) in costs of R&D.

4.2.2 System Investment Costs

The System Investment Costs subcategory is defined as hardware procurement costs and program/project management costs. The cost element of Procurement covers only production hardware and includes unit cost, installation cost, and integration cost. The element of Program/Project Management includes technical and administrative planning, organizing, directing, coordinating, controlling, and approving.

Although the Procurement cost element was readily quantified in this study, the Program/Project Management cost was set to zero because of a lack of adequate information. As a result, the DAIS configuration has a 3.3 percent (\$22,570,000) higher System Investment

Table 4.2 - Expanded Nonrecurring Costs.

<u>Category</u>	<u>Subcategory</u>	<u>Element</u>	<u>Non-DAIS Cost (\$000)</u>	<u>DAIS Cost (\$000)</u>	<u>Cost Difference (\$000)</u>	<u>% Difference</u>
NRC-Non-Recurring						
	CRD-Research & Development		5,340	6,210	+ 870	+16.3%
	CSI-System Investment					
		CPP-Procurement	67,719	90,289	+22,570	+33.3%
		CPM-Project Management	0	0	0	0.0%
	COI-Support Investment					
		CPTI-Maintenance Training	0	0	0	0.0%
		CSPI-Spares	16,742	14,330	-2,412	-14.4%
		CDRI-SE, Depot	22,176	23,636	+1,460	+6.6%
		CSEI-SE, Field	15,051	17,697	+2,646	+17.6%
		CSWI-Software Acquisition	5,317	1,997	-3,320	-62.4%
		CJGI-Maintenance Manuals	1,769	2,095	+ 326	+18.4%
		CIMI-Inventory Management	5	12	+ 7	+140.0%
		CFAI-Facilities	0	0	0	0.0%
Total NRC			134,119	156,266	+22,147	+16.5%

cost. This increase is attributable to the higher unit cost for the DAIS equipment relative to the LRUs they are replacing. Unit costs of conventional avionics hardware are based on mature systems which may represent reduced costs due to quantity buys, whereas the DAIS hardware reflects cost values based on limited buys to date. Furthermore, there is more redundancy in the DAIS configuration.

This redundancy offers the advantage of increased operational capability and readiness. It also ensures that the capability and space allocation will accommodate any future growth of the DAIS to satisfy additional system requirements. The memory capacity of the four DAIS processors is only 63 percent utilized as compared with the memory capacity of the non-DAIS computer being exceeded for a comparable capability. Since only three processors and BCIUs are required at this time, the DAIS cost estimate is higher than it need be. No adjustment has been made to the DAIS cost for any improved operational capability and readiness.

4.2.3 Support Investment Costs

The subcategory of Support Investment Costs includes all costs associated with supplying logistics support requirements for a weapon system. These costs reflect the initial investment for necessary supplies and services to support a new weapon system. The 2.1 percent (\$1,293,000) decrease in the Support Investment Costs subcategory for a DAIS configuration (shown previously in Table 4.1) was subdivided into eight cost elements in Table 4.2. These cost elements are:

Cost of Initial Maintenance Training

Costs incurred in setting up a training program. This element was set to zero in the model.

Cost of Spares Investment

Costs associated with three types of spares: (1) LRUs and SRUs, (2) piece-parts and material, and (3) war reserve materials. The calculations indicate that the DAIS configuration would result in a 14.4 percent cost decrease (\$2,412,000) in this element. War reserve material was ignored since it would be essentially equal for either configuration. This significant lower spares cost is attributable to the reduction in the number of spares required because of the improvement in reliability of the DAIS core units in relation to the conventional LRUs they replace for accomplishing the same functions.

Cost of Depot Support Initial

The initial investment costs of the equipment peculiar and associated common support equipment with the overhaul manuals required to supply the depot overhaul and repair sites. The

DAIS configuration results in a 6.6 percent higher cost (\$1,460,000) in this element. This higher cost value for the DAIS SE requirements was caused by treating the non-DAIS LRU test stations as sunk costs since they would already be located at the depots. A cost of \$11,000,000 would have been added to the conventional avionics depot SE if the non-DAIS LRU test stations had been included.

Cost of Support Equipment Initial

Costs associated with the initial investment for base level SE. The DAIS configuration would result in a 17.6 percent higher cost of \$2,646,000 for this element. This difference results from the higher unit costs of the DAIS test stations.

Cost of Software Acquisition

Costs associated with software development personnel costs and associated computer operation costs. The DAIS configuration would result in a 62.4 percent less cost (\$3,320,000) in this element. The lower cost for development of the DAIS operational and support software results from the increased productivity that is attributable to the use of a HOL and a standardized architecture. The development of support software for a non-DAIS configuration comparable to that developed for the DAIS accounts for most of this cost element.

Cost of Maintenance Manuals

The cost of maintenance manuals required for organizational (flightline) and intermediate (shop) level maintenance. The DAIS configuration would result in a 18.4 percent higher cost (\$326,000) for this element. This higher cost results primarily from the assumption that the DAIS will use newer proceduralized manuals which cost more per page.

Cost of Inventory Management Initial

Costs associated with the stocking, control, and supply of spare parts. The DAIS configuration would result in a 140 percent higher cost (\$7,000) for this element. This higher cost of DAIS is attributable to the new SRUs introduced. The cost value is insignificant in respect to other cost elements, however.

Cost of New or Additional Facilities

Costs associated with the construction, conversion, or expansion of any necessary facilities required to house or support the various services needed by a new weapon system. This element was set to zero.

Table 4.3 – Expanded Recurring Costs.

<u>Category</u>	<u>Subcategory</u>	<u>Element</u>	<u>Non-DAIS Cost (\$000)</u>	<u>DAIS Cost (\$000)</u>	<u>Cost Difference (\$000)</u>	<u>% Difference</u>
RC--Recurring (for PIUP=15 years)						
	CO--Operation					
		CFL--Fuel	0	0	0	0.0%
		COP--Personnel				
		CAC--Aircrew	0	0	0	0.0%
		COO--Other Operations	0	0	0	0.0%
	CS--Support					
		COM--On-Equipment Maintenance	26,682	13,554	-13,128	-49.2%
		CSM--Intermediate Maintenance	22,856	14,419	-8,437	-36.4%
		CPT--Training	13,152	8,330	-4,822	-36.7%
		CSP--Spares	11,824	10,344	-1,480	12.5%
		CDR--Depot Maintenance	33,767	27,799	-5,968	-17.7%
		CSE--Support Equipment	6,753	8,356	+1,603	+23.7%
		CSW--Software	4,209	2,562	-1,647	-39.1%
		CJG--Maintenance Manuals	1,990	2,357	+ 367	+18.4%
		CIM--Inventory Management	229	532	+ 303	+132.3%
Total RC			121,462	88,253	-33,209	-27.3%

4.3 RECURRING COSTS

The Recurring Costs category includes costs generated during the operation and support phase of the weapon systems life cycle. Table 4.3 summarizes the Recurring Costs for both DAIS and non-DAIS. The \$33,208,000 advantage of DAIS over the non-DAIS is significant. It represents 27.3 percent savings over the 15-year usage period.

Table 4.3 indicates that although certain cost elements have a considerable impact on the overall LCC, they are partially offset by other cost elements. For example, the large reductions in cost for DAIS are contributed by the cost elements of On-Equipment Maintenance, Intermediate Maintenance, Personnel Training, Replacement Spares, Depot Maintenance, and Software Support. These elements provide a DAIS cost savings of \$35,483,000. This savings is slightly offset, however, by the \$2,272,000 higher cost contributed by the base level SE, Maintenance Manuals, and Inventory Management cost elements.

The following subsections will describe each of the cost sub-categories and elements associated with the Recurring Cost category. They also indicate the percentage increase/decrease in LCC attributable to the DAIS configuration with the actual dollar difference.

4.3.1 Operation Costs

The Operation Costs subcategory consists of two principal cost elements: Operations Personnel (including aircrew) and Fuel. These two cost elements are independent of the avionics configuration (in this scenario) and have been set to zero for this DAIS/non-DAIS comparison.

4.3.2 Support Costs

The subcategory of Support Costs includes the cost of personnel, equipment, spares, materials, and supplies needed to support the deployed units. The type of support required by the weapon system includes organizational level maintenance personnel and equipment, as well as fully-equipped and staffed intermediate and depot level maintenance facilities. Support Costs include the following nine cost elements.

Cost of On-Equipment Maintenance

The costs of manpower and material needed to perform the organizational level flightline scheduled and unscheduled maintenance on unit aircraft. The DAIS configuration would result in a 49.2 percent less cost (\$13,128,000) in this element. This lower cost is attributable to the reduced maintenance manhours per flight-hour (MMH/FH) required for DAIS brought about by the improved reliability and the use of a central integrated test system (CITS) resulting from the DAIS architecture.

Cost of Intermediate Shop Maintenance

The costs of manpower and material needed to perform intermediate shop maintenance. This includes manpower to accomplish SE repair. The DAIS configuration would result in a 36.4 percent lower cost (\$8,432,000) in this element. The reduced MMH/FH is due to the employment of a central integrated test system (CITS) and a consolidated SE.

Cost of Maintenance Personnel Training

Costs associated with training the initial work force of organizational and intermediate level maintenance personnel, and the annual cost of training their replacements. The DAIS configuration would result in a 36.7 percent lower cost (\$4,822,000) for this element, directly attributable to the reduced manpower and associated skill levels required for DAIS flightline troubleshooting due to improved diagnostic capability. This same diagnostic capability, inherent in a central integrated test system, also reduces the number of false failure indications.

Cost of Replacement Spares

The annual costs of replacing condemned LRU and SRU spares in the shop and depot pipeline. The DAIS configuration would result in a 12.5 percent less cost (\$1,480,000) in this element. The reduction in spares is due to the improved reliability of the DAIS core equipment over the units they replace.

Cost of Depot Repair

The recurring depot cost of repairing LRUs and SRUs by subsystem, including their shipping costs. The DAIS configuration would result in a 17.7 percent lower cost (\$5,968,000) for this element, attributable to the improved aggregated reliability in the DAIS core element LRUs over the conventional LRUs they replace.

Cost of Maintaining Support Equipment

The annual costs of the peculiar avionics shop SE unscheduled maintenance excluding manpower costs. The DAIS configuration has a 23.7 percent higher cost (\$1,603,000) for this element. This higher cost is a direct result of the higher procurement cost for the more complex base level DAIS SE. This value reflects the higher cost of replacement spares based on a proportion of that cost.

Cost of Software Support

The costs of labor and computer costs required to perform software maintenance. The DAIS configuration would result in a 29.1 percent less cost (\$1,647,000) for this element, a result of a reduction in the average manpower required for the DAIS support. This reduction results from both the potential quality of the software initially delivered and the productivity factor attainable when using DAIS software.

Cost of Maintenance Manuals Support

The cost of supporting maintenance manuals incurred for updating, improving, or correcting the manuals. The DAIS configuration would result in a 18.4 percent higher cost (\$367,000) in this element, a direct result of the higher procurement cost of the manual.

Cost of Inventory Management

The cost of managing the Air Force inventory of spare parts to support a weapon system. The DAIS configuration would result in a 132.3 percent cost increase (\$303,000) in this element due to the introduction of new SRUs for the DAIS.

4.4 COST OF SYSTEM DISPOSAL

The Cost of System Disposal category includes the expenses incurred, as well as any income derived from the termination of a weapon system at the end of its economic life. For example, these costs would include salvage value costs such as "mothball" storage. The Cost of System Disposal category has been set to zero for this study for purposes of the DAIS impact analysis since either configuration would have equal (negligible) cost values.

4.5 IMPACT OF STANDARDIZATION

When generating the LCC comparison in this study, the DAIS concept was applied to a single aircraft type and a fixed complement of subsystems. The full effect of the concept can be realized only by extending its application through standardization across aircraft types and subsystems. The effects of such extensions are attempted on a first-cut basis in this section. This is not meant to be a full and definitive evaluation of the benefits offered by standardization through a DAIS design. Rather, it serves as an example of the approach to use in conducting such a study.

4.5.1 Extending the DAIS Concept Across Aircraft Types

The design of conventional avionics for each new aircraft type tends to be unique, having little in common with predecessor aircraft. System affordability could be enhanced by introducing any

commonality into future acquisition and retrofit programs. For example, standardization of DAIS core elements can significantly reduce the net LCC impact of these future aircraft programs. To quantitatively assess this possible savings, extension of the DAIS concept to additional aircraft types is evaluated in this section on an LCC basis under the following hypothetical conditions.

A new aircraft type has a mission that probably differs from the CAS mission. Consequently, the avionics configuration could also differ from the DAIS or non-DAIS baseline configurations. However, it is assumed that the reliability, maintainability, and cost parameter values for the new aircraft type are set equal to baseline values. Using a non-DAIS baseline, avionics for 72 aircraft of the added type would have the same LCC as that for the 72 CAS aircraft. In the case of a DAIS baseline, the DAIS core common to both aircraft types affects the cost parameters shown in Table 4.4.

The parameter changes in Table 4.4 reflect the effect of standardization of 28 LRUs across two aircraft types. The cost impact of this specific example of standardization was computed by the RMCM model as shown in Table 4.5. Table 4.5 indicates that a \$23,653,000 savings in LCC will be realized for the added DAIS application. The major contributor to this savings is the \$17,236,000 reduction due to standardization of depot SE (whereby the cost of DAIS depot SE procured to support LRUs contained in the baseline aircraft type is treated as a sunk cost).

An additional result of standardization is the learning curve effect defined as the productivity resulting from an increase in production quantity. Under this learning curve effect, the average unit cost reduces to a certain percentage of its prior value each time the amount of units to be produced is doubled.

$CP = A \cdot \left(\frac{P'}{P}\right)^b$	
<p>CP Unit cost for new production unit. A Unit cost of reference production lot. P' New production lot size. P Reference production lot size. b Negative exponent defining slope of log linear learning curve.</p>	

The slope of the curve is determined by the technology, cost of materials, use of capital, and lessons learned from the prior experience. Using the avionics industry value of an 85 percent learning curve slope (such that $CP/A = 0.85$ for $P'/P=2$; therefore, $b=-.2345$), the impact of the learning curve effect on unit cost is shown in Table 4.6.

Table 4.4 – Effect of Standardization on Cost Elements.

	Perturbation of Original Value	Rationale for Perturbation
Nonrecurring		
1. Research & Development (CRD)	$\frac{67}{95} = 0.7$ CRD	Of the 95 LRUs in the system, only the 56 sensors and the 11 core LRUs that interface with those sensors need any redesign.
2. Procurement (CPP) ● Integration Costs (IC)	$IC_i = 0$ for core	Only sensor SRUs require integration and new qualification testing.
3. Depot Support Equipment (CDRI)	Use 2/3 of original SE costs for SRU repair.	Only the sensor SRUs will require additional test stations. The LRU test stations are now sunk costs, just as the original non-DAIS was treated.
4. Software (CSWI) ● No. of words (NW)	0.7 NW	Only sensor and interface core elements require new DAIS software for OFF/OTP
5. Maintenance Manuals (CJGI)	0.7 CJGI	Only portions of the manuals required for new LRUs/SRUs need development.
6. Inventory Management Initial (CIMI) ● No. of repairable SRUs (PA)	PA = 0	No new repairable SRUs required for DAIS core.
Recurring		
7. Maintenance Manual Support (CJG)	0.7 CJG	The changes/corrections required for DAIS core information will be negligible as time goes on.
8. Personnel Training (CPT)	---	Course material changes for only portion of core; however, course lengths were considered constant for both configurations.

Table 4.5 – Impact of DAIS Application to an Additional Aircraft Type.

<u>Impacted Cost Elements</u>	<u>Cost of Baseline Aircraft Type (\$000)</u>	<u>Cost of Additional Aircraft Type (\$000)</u>	<u>Cost Impact (\$000)</u>
Non-recurring			
● CRD	6,210	4,347	-1,863
● CPP	90,289	89,230	-1,059
● CDRI	23,636	6,400	-17,236
● CSWI	1,998	200	-1,798
● CJGI	2,095	1,466	-628
● CIMI	12	4	-8
Recurring:			
● CJG	2,357	1,650	-707
● CIM	532	178	-354
		$\Delta LCC =$	-23,653

Table 4.b – Impact of Learning Curve Effect.

Number of Aircraft Type (72 A/C each)	Cost per Aircraft			Net LCC Savings per Aircraft
	Procurement Cost (CPP) of Core Subsystems	Initial Spares Cost (CSPI) of Core Subsystems	Recurring Spares Cost (CSP) of Core Subsystems	
1	651,590	47,759	30,677	0
2	553,852	40,595	26,075	54,752
3	503,604	36,912	23,710	91,767
4	470,751	34,504	22,163	119,478
5	446,751	32,745	21,033	141,481
6	428,054	31,375	20,153	159,641

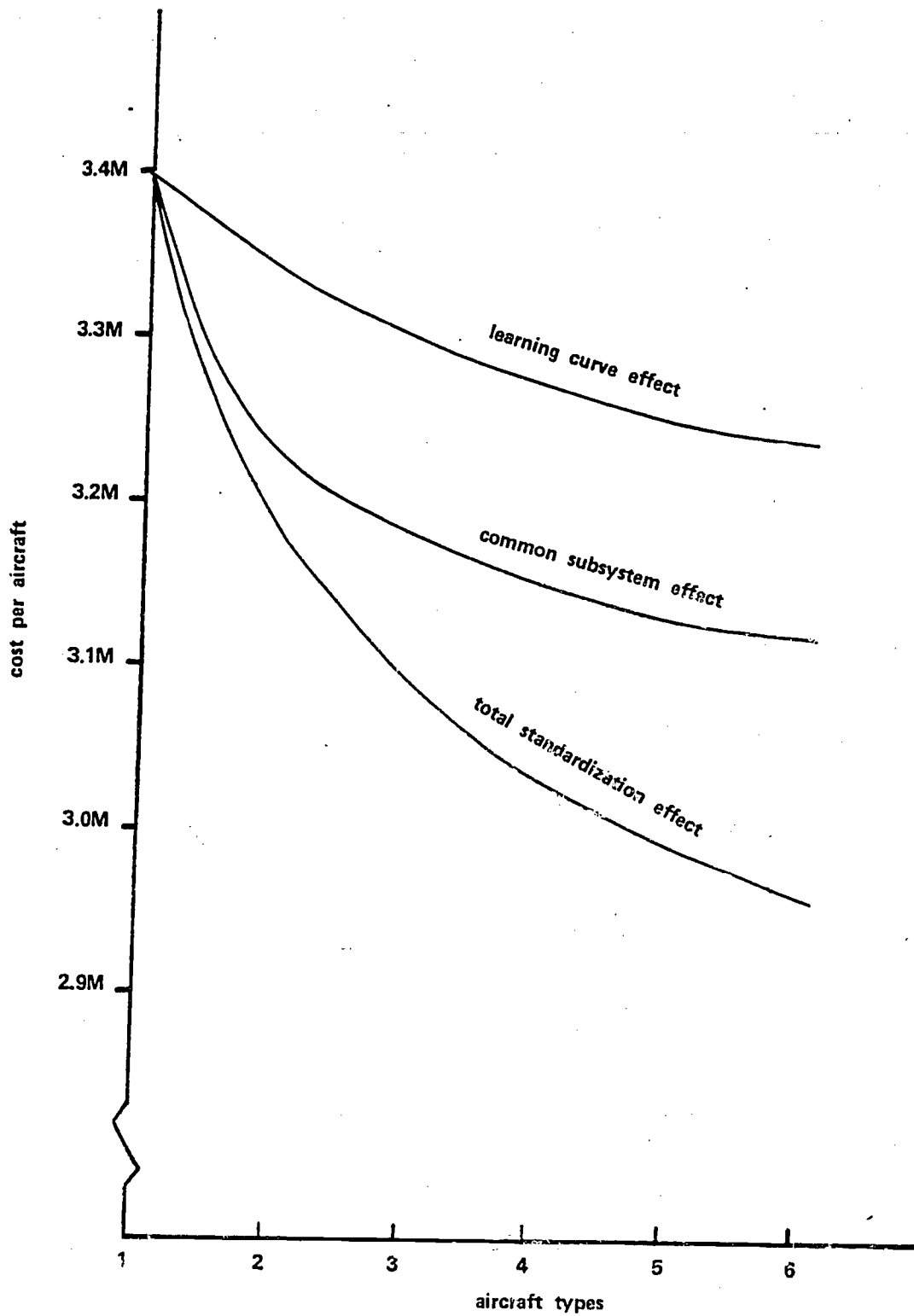

Figure 4.1 — Effect of standardization on avionics cost per aircraft.

The procurement and spares cost per aircraft decreases with each additional DAIS application. The net savings per aircraft that results with each application to an additional aircraft type is also shown in Table 4.6.

The common subsystem effect, as shown in Table 4.5, and the learning curve effect in Table 4.6 are combined in Figure 4.1 to show the total effect of standardization on cost per aircraft as a function of added aircraft types (72 aircraft of each type). These two effects are shown separately because they are functions of different parameters.

Investment in common DAIS subsystems can be considered a fixed cost which can be shared across aircraft types. Consequently, the reduction in LCC due to additional aircraft applications is a function of the reliability, maintainability, and cost characteristics of the common subsystems relative to the characteristics of the total complement of subsystems. The learning curve effect tends to be a function of the number of aircraft and the slope of the learning curves.

4.5.2 Extending the DAIS Concept Across Subsystems

The extension of the DAIS concept across subsystems can occur through a retrofit of the defined avionics. Retrofit is a change in original design resulting in the deletion, substitution, or addition of a subsystem. To study the impact of a retrofit, a new subsystem was added to each avionics configuration. This added subsystem exhibits the same reliability and maintainability characteristics as one selected from the present configuration in that it consumes the average amount of maintenance manhours (such as the VHF radio). No existing equipment or wiring needed to be removed to install this new system.

The impact of the addition of this subsystem on each LCC element is shown in Table 4.7. The table indicates that the cost of adding a subsystem is \$1,514,000 (41 percent) less for the DAIS configuration. Savings occur in the nonrecurring and the recurring cost elements. The recurring cost elements in the non-DAIS configuration, however, dominated the increased costs required to support the new subsystem.

It should be noted that no software requirement was charged to the non-DAIS configuration because the new sensor was considered to require only a switching mechanism. To make a cost comparison for a retrofit involving extensive software change, consider the case where a new navigation subsystem is added. The software required for the non-DAIS configuration indicated an increased initial cost of \$604,000 as compared to \$27,000 for the DAIS configuration. The cost of adding this navigation subsystem is \$2,093,000 (94 percent) less for DAIS configuration in respect to the conventional avionics.

Table 4.7 - Cost Impact of Adding a Subsystem.

Cost Categories	Conventional + One New Conventional Subsystem		DAIS	DAIS + One New Subsystem
	(\$000)	(\$000)	(\$000)	(\$000)
Non-Recurring (NR):				
• CRD	5,340	5,341	6,210	6,210
• CPP	67,719	68,587	90,289	91,102
• CSPI	16,742	16,820	14,330	14,396
• CSEI	15,051	15,660	17,697	17,697
• CJGI	1,769	1,821	2,095	2,164
• CIMI	5	6	12	13
• CDRI	22,176	22,176	23,636	23,636
• CSWI	5,317	5,317	1,998	2,000
Recurring (R):				
• COM	26,682	27,211	13,554	13,856
• CSM	22,856	23,480	14,419	14,875
• CPT	13,153	13,492	8,330	8,531
• CSP	11,824	11,892	10,344	10,402
• CDR	33,767	33,904	27,799	27,915
• CSE	6,752	7,057	8,356	8,356
• CJG	1,990	2,048	2,357	2,435
• CIM	229	287	532	583
• CSW	4,209	4,209	2,562	2,562
LCC (NR+R)	\$255,581	\$259,308	\$244,520	\$246,733
Δ LCC		+ 3,727		+ 2,213

The estimate is based on the non-DAIS configuration requiring an additional 6746 words as compared to only 1600 more words required by the DAIS.

4.6 INFLATION EFFECTS

Inflation has an effect on the Recurring Costs category. The DAIS concept has already shown a recurring cost advantage over the DAIS concept. The reductions in operational support requirements permitted by the DAIS affect the cost drivers hit hardest by inflation. An inflation factor was applied to clarify this additional cost advantage of a DAIS implementation.

Table 4.8 (which is plotted in Figure 4.2) indicates the effect of adding a six percent inflation rate to the recurring cost components of LCC. When inflation is not considered, the DAIS avionics suite (dashed line in Figure 4.2) is shown as capable of avoiding approximately \$11 million (4.3 percent) of the \$256 million estimated as the LCC of the comparable conventional avionics suite (dotted line in Figure 4.2). However, if inflation is considered over a 15-year span in the calculations, the DAIS cost avoidance potential jumps to \$30.7 million which is 9.4 percent of the \$328 million LCC for the conventional avionics.

It should be noted that, for practical purposes, the initial procurement cost which is higher for DAIS than for conventional avionics is essentially not affected by inflation (all nonrecurring costs occur in base year). The combination of effects acts to more quickly offset the higher initial acquisition cost of a DAIS package. This fact is illustrated by the crossover point of the comparative cumulative cost curves (shown in Figure 4.2) moving to a lesser number of years because of inflation.

4.7 EFFECT OF THE DAIS CONCEPT ON SERVICE AVAILABILITY

One of the products of the RCM computer program (see Output Report 6) is the calculation of the inherent availability for each subsystem, using the following equation for flightline maintenance events.

$$A = \frac{MFHBMA}{MFHBMA + MTTR}$$

Multiplying the subsystem values for A for each configuration shows that the total service availability of DAIS is 0.3321, which is 86 percent higher than the 0.1781 value for the non-DAIS. Although this measure of readiness cannot be equated to dollars, it is a major concern to the USAF using commands.

Table 4.8 - Effect of Six Percent Inflation on LCC.

A - Conventional Avionics LCC			
*ADJLCC	1976 Dollars	Inflated	% Change
NR 1976	134,118,840	134,118,840	0
RC 1977	8,097,481	8,340,405	3.0
RC 1978	8,097,481	8,840,830	9.2
RC 1979	8,097,481	9,371,280	15.7
RC 1980	8,097,481	9,933,556	22.7
RC 1981	8,097,481	10,529,570	30.0
RC 1982	8,097,481	11,161,344	37.8
RC 1983	8,097,481	11,831,025	46.1
RC 1984	8,097,481	12,540,886	54.9
RC 1985	8,097,481	13,293,340	64.2
RC 1986	8,097,481	14,090,940	74.0
RC 1987	8,097,481	14,936,396	84.5
RC 1988	8,097,481	15,832,580	95.5
RC 1989	8,097,481	16,782,535	107.3
RC 1990	8,097,481	17,789,487	119.7
RC 1991	8,097,481	18,856,857	132.9
DP 1992	0	0	0
Total	255,581,070	328,249,876	28.4

B - DAIS LCC			
*ADJLCC	1976 Dollars	Inflated	% Change
NR 1976	156,266,242	156,266,242	208.5
RC 1977	5,883,566	6,060,073	3.0
RC 1978	5,883,566	6,423,677	9.2
RC 1979	5,883,566	6,809,098	15.7
RC 1980	5,883,566	7,217,644	22.7
RC 1981	5,883,566	7,650,703	30.0
RC 1982	5,883,566	8,109,745	37.8
RC 1983	5,883,566	8,596,330	46.1
RC 1984	5,883,566	9,112,110	54.9
RC 1985	5,883,566	9,658,836	64.2
RC 1986	5,883,566	10,239,366	74.0
RC 1987	5,883,566	10,852,668	84.5
RC 1988	5,883,566	11,503,829	95.5
RC 1989	5,883,566	12,194,058	107.3
RC 1990	5,883,566	12,925,702	119.7
RC 1991	5,883,566	13,701,244	132.9
DP 1992	0	0	0
Total	244,519,732	297,320,325	21.3

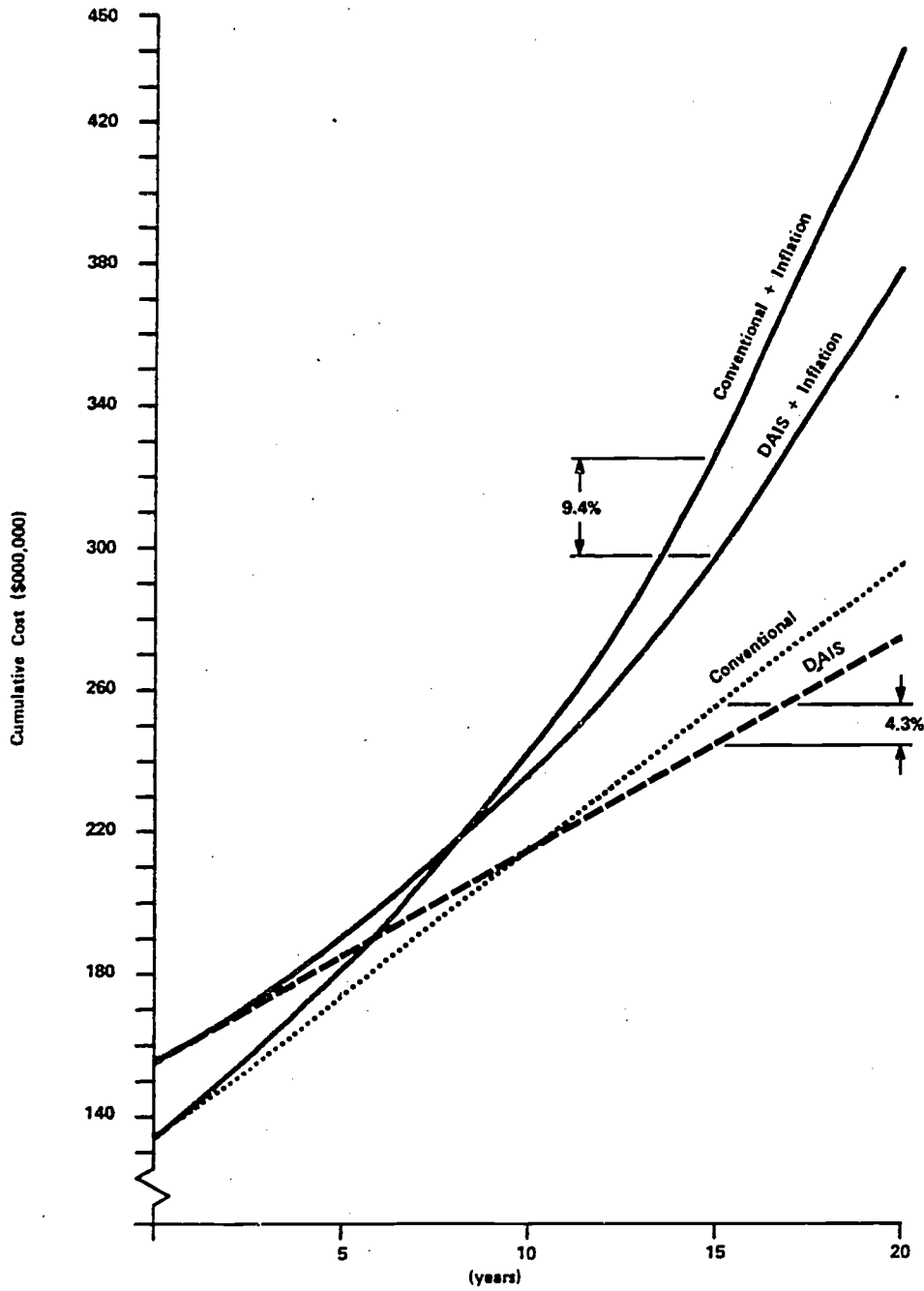

Figure 4.2 — Inflation effects.

V. CONCLUSIONS AND RECOMMENDATIONS

The LCC comparison of this study between a DAIS avionics suite and a conventional avionics suite for a specific CAS mission showed that DAIS had a lower (4.3 percent) LCC at the end of 15 years of operation (refer to Figure 5.1). It had a considerably higher (16.5 percent) nonrecurring cost than the conventional avionics, mainly because the increased procurement cost (CPP) outweighed the savings in spares (CSPI) and software acquisition (CSWI). This is illustrated in Figure 5.2 which provides a comparative histogram of the contributions that each nonrecurring cost (NRC) element makes to the LCC of both avionics configurations. All other NRC elements were higher for DAIS with the costs of R&D (CRD), depot support acquisition (CDRI), and field support equipment acquisition (CSEI) as the major contributors totalling increased costs of approximately \$5,000,000 over the conventional avionics. It should be noted that the depot support equipment acquisition cost for the non-DAIS configuration was treated as a sunk cost. If considered as a new buy, this cost would have totalled \$11,000,000 and the nonrecurring costs of the conventional would exceed the DAIS configuration by \$6,000,000. Cost increases resulting from maintenance manual acquisition and inventory management elements were insignificant in terms of their dollar value.

Figure 5.3 provides the comparative histograms for the recurring cost element contributions to LCC. The recurring costs of DAIS were 27.3 percent lower than the conventional avionics, mainly because its concept results in R&M characteristics which demand less on-equipment maintenance (COM), less shop maintenance (CSM), and less depot repair (CDR).

The comparative impact of an avionics retrofit program was evaluated by adding a typical subsystem, with minor software requirements, to both a conventional and a DAIS configuration. The results showed that the DAIS has a potential uninflated \$1.9 million advantage in LCC over the conventional configuration if the avionics retrofit of 72 aircraft occurred in the first year.

An example of an operational term that benefits from a DAIS configuration is the 88 percent improvement in service availability that it provides. Although this measure of readiness cannot be equated to dollars, it is of natural concern to the USAF using command.

The LCC comparison presented in this report represents two sets of cost estimates for a particular set of conditions. The cost analysis is based on the best available data and, therefore, it is recommended that the results be established as a baseline for future DAIS trade-off studies of alternative sets of conditions. In addition, it is recommended that the historical data be replaced by data from actual DAIS equipment as it becomes available so that the LCC assessment can be maintained current.

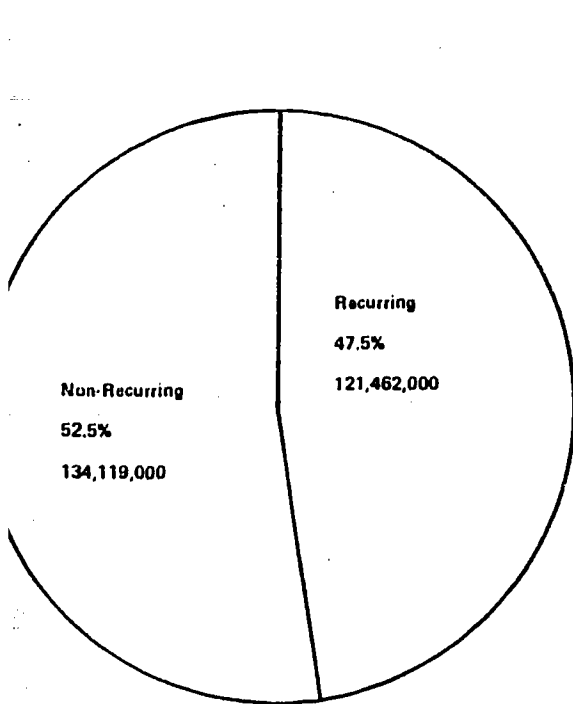

Total Non-DAIS Life Cycle Cost
in 1976 dollars = 255,581,000

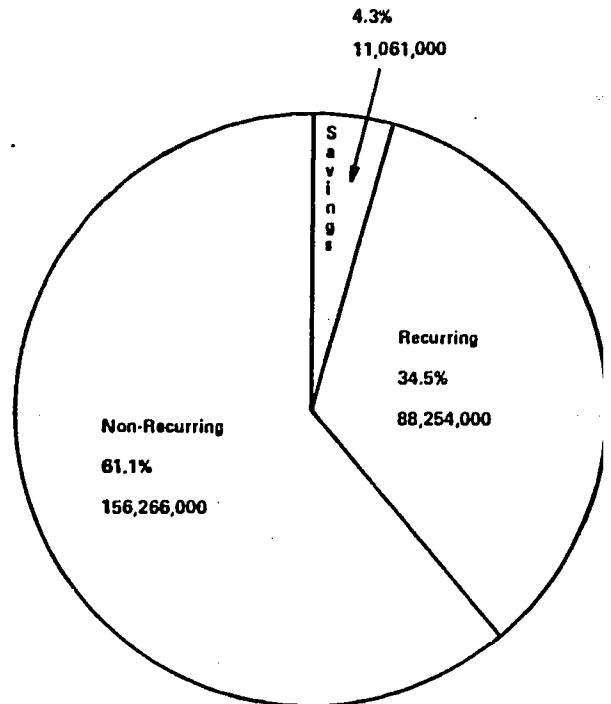

Total DAIS Life Cycle Cost
in 1976 dollars = 244,520,000

Figure 5.1 – Contributions to LCC by cost category.

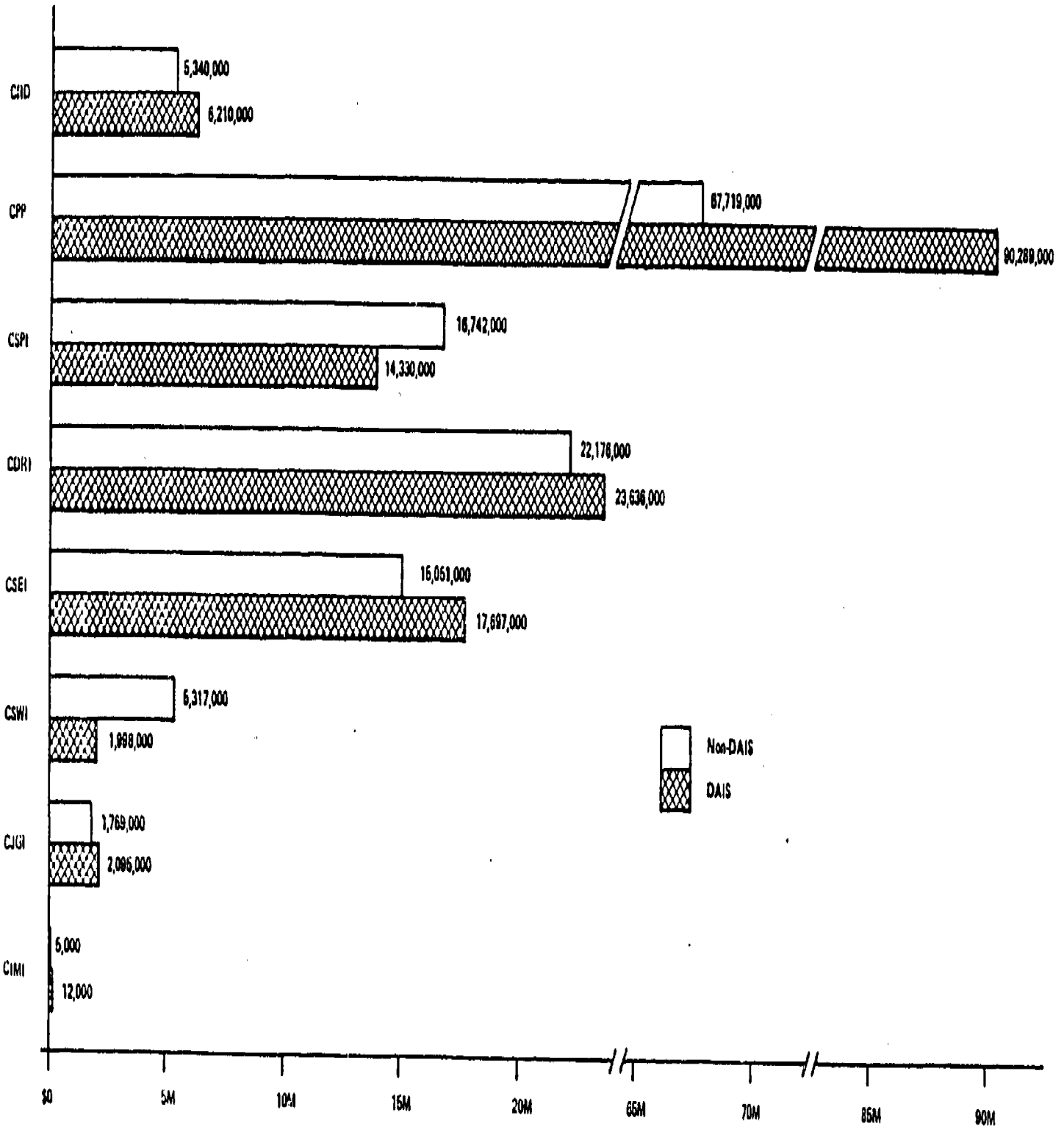

Figure 5.2 - Contributions to LCC by nonrecurring cost elements.

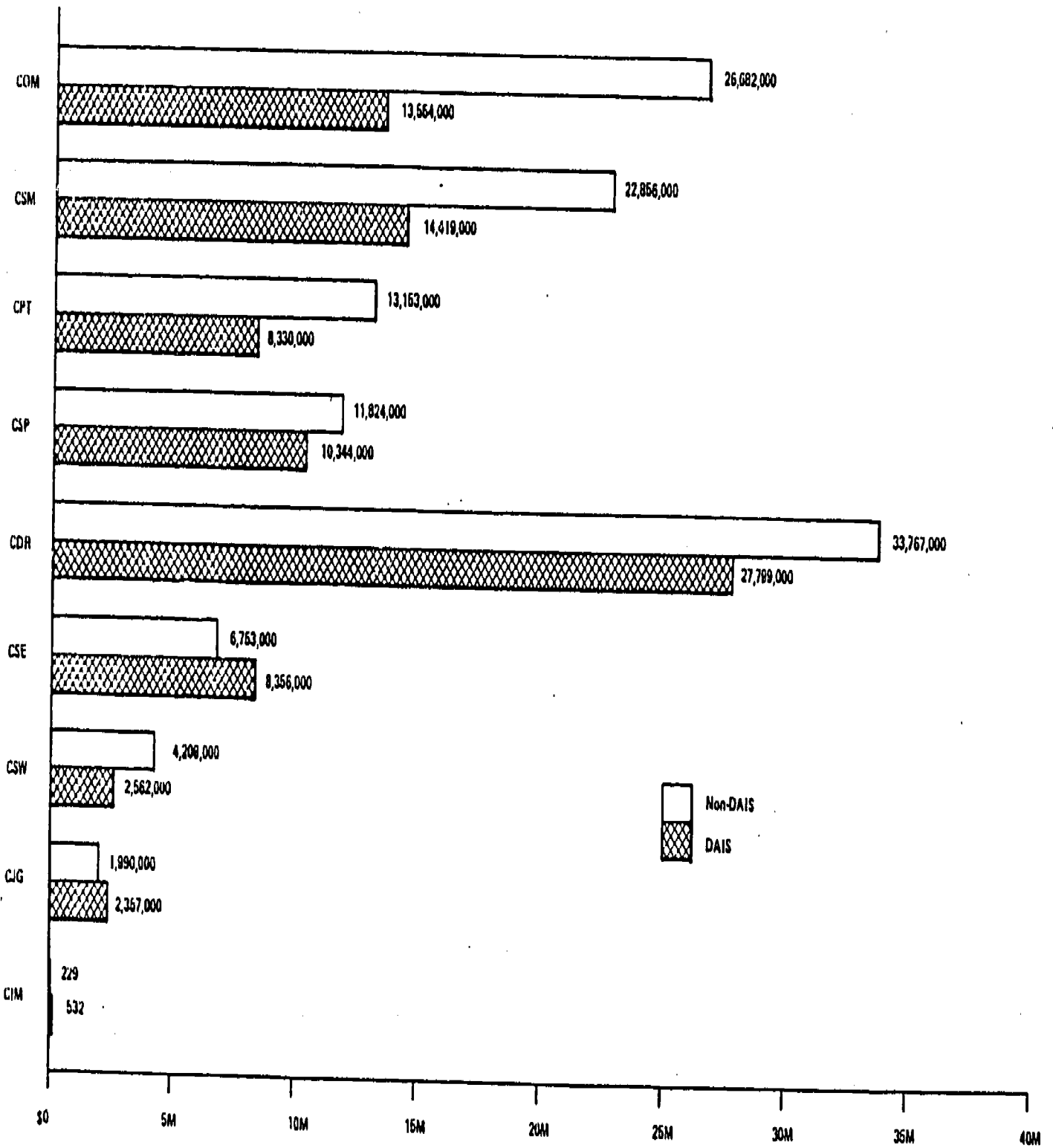

Figure 5.3 – Contribution to LCC by recurring cost element.

The substantiating data and assumptions provided in this report are sufficiently detailed so that management can readily analyze the potential for cost savings and improved capability exhibited by the DAIS concept. Although the LCC savings of the basic DAIS design over a conventional avionics design appears to be modest at first, the true potential is appreciated only when the following conditions are considered in depth.

1. Cost savings to be realized from standardization across aircraft types.
2. High cost of aircraft retrofit programs particularly when software changes and rewiring are involved.
3. Cost reduction due to consolidation of support facilities.
4. Increased performance of processors, displays, and software that offset the acquisition cost of DAIS.
5. DAIS cost avoidance potential because of its lower recurring costs which are susceptible to inflation.

REFERENCES

1. Gocłowski, J.C., J.M. Glasier, R.H. Kistler, M.A. Bristol, H.A. Baran, Digital avionics information system (DAIS): Life cycle cost impact modeling system reliability, maintainability, and cost model (RMCM)--Description users guide. AFHRL-TR-79-65: Wright-Patterson AFB, OH: Logistics and Technical Training Division, Air Force Human Resources Laboratory, August 1980. (AD-A039 045)
2. Czuchry, A.J., K.M. Doyle, J.T. Fruen, H.A. Baran, D.L. Dieterly, Digital avionics information system (DAIS): Training requirements analysis model (TRAMOD). AFHRL-TR-78-58(1), Wright-Patterson AFB, OH: Advanced Systems Division, Air Force Human Resources Laboratory, April 1979. (AD-A068 474)
3. Czuchry, A.J., J.M. Glasier, R.H. Kistler, M.A. Bristol, H.A. Baran, D.L. Dieterly, Digital avionics information system (DAIS): Reliability and maintainability model users guide. AFHRL-TR-78-2(II), Wright-Patterson AFB, OH: Advanced Systems Division, Air Force Human Resources Laboratory, April 1979. (AD-A068 826)
4. Gocłowski, J.C., & H.A. Baran, Digital avionics information system (DAIS): Life cycle cost impact modeling system (LCIM)--A managerial overview. AFHRL-TR-79-64. Wright-Patterson AFB, OH: Logistics and Technical Training Division, Air Force Human Resources Laboratory, November 1980. (AD-A093 281)

BIBLIOGRAPHY

- AFHRL/ASD, Dynamics Research Corporation Report E-4735U. Technical order content and cost algorithms (Modifications of the JPA algorithms). August 1978.
- Air Force Manual 177-101. Basic systems at base level, Washington, D.C.: Department of the Air Force, 1 August 1968.
- Air Force Manpower Source Listing for A-7D Maintenance Functions at England AFB. Langley Air Force Base, Virginia: 4400 Management Engineering Squadron, Tactical Air Command, October 1977.
- Air Force Manual 50-5. USAF formal schools catalog: Course announcement, Volume II. Washington, D.C.: Department of the Air Force, 1 September 1976.
- Air Force Table of Allowances 293. USAF series A-7D weapon system. Washington, D.C.: Department of the Air Force, December 1975.
- Air Force Table of Allowances 289, USAF series F-15 weapon system. Washington, D.C.: Department of the Air Force, January 1976.
- Air Force Regulation 65-57. Uniform clothing allowances for airmen. Washington, D.C.: Department of the Air Force, 30 September 1975.
- Balkovich, E. E. A method of estimating the cost of avionics software. RM-1982. General Research Corporation, Santa Barbara, CA, May 1975.
- Betaque, Jr., N. E.; M. R. Fiorello. Aircraft system operating and support costs: Guidelines for analysis. Logistics Management Institute, March 1977.
- Brodnax, C. T. A conceptual study for a digital avionics information system (Approach II). Wright-Patterson AFB, OH: Air Force Avionics Laboratory, Air Force Systems Command, March 1974.
- Brooks, F. P., Jr., The mythical man-month. Addison-Wesley Publishing Company, Reading, MA., 1975.
- Brown, F. D.; G. A. Walker, D. H. Wilson. Life cycle cost of C-130E weapon system. AFHRL-TR-77-46, Wright-Patterson Air Force Base, Advanced Systems Division, Air Force Human Resources Laboratory, July 1977. (AD-A044 040)
- Computer program development specification for operational flight program applications software DAIS mission A type B-5. SA201303 Pt. 1. Wright-Patterson AFB, OH: Systems Avionics Division, DAIS Advanced Development Program Office, July 1976.

- Czuchry, A. J., K. M. Doyle, J. T. Frueh, H. A. Baran and D. L. Dieterly. Digital avionics information system (DAIS): Training requirements analysis model users guide. AFHRL-TR-78-58 (II), Wright-Patterson AFB, OH: Advanced Systems Division, Air Force Human Resources Laboratory, September 1978. (AD-A061 589).
- Czuchry, A. J., J. M. Glasier, R. H. Kistler, M. A. Bristol, H. A. Baran and D. L. Dieterly. Digital avionics information system (DAIS): Reliability and maintainability model. AFHRL-TR-78-2 (I), Wright-Patterson AFB, OH: Advanced Systems Division Air Force Human Resources Laboratory, April 1978. (AD-A056 530)
- Czuchry, A.J., R.H. Kistler, J.M. Glasier, M.A. Bristol, H.A. Baran, D.L. Dieterly. Digital avionics information system (DAIS): Reliability and maintainability model users guide. AFHRL-TR-78-2(II), Wright-Patterson AFB, OH: Advanced Systems Division, Air Force Human Resources Laboratory, April 1979. (AD-A068 826)
- Czuchry, A. J., H. E. Engel, J. M. Glasier, M. A. Bristol, H. A. Baran, D. L. Dieterly. Digital avionics information system (DAIS): Mid-1980s maintenance task analysis. AFHRL-TR-77-45, Wright-Patterson AFB, OH: Advanced Systems Division, Air Force Human Resources Laboratory, July 1977. (AD-A047 886)
- Czuchry, A. J., H. E. Engel, R. A. Dowd, H. A. Baran, D. L. Dieterly, R. Greene. A mid-1980s digital avionics information system conceptual design configuration. AFHRL-TR-76-59, Wright-Patterson AFB, OH: Advanced Systems Division, Air Force Human Resources Laboratory, July 1976. (AD-A032 137)
- Daley, E. G. Management of software development. IEEE Transactions on Software Engineering, Vol. SE-3, No. 3, May 1977.
- Dover, L. E., W. E. Oswald, Jr.. A summary and analysis of selected life cycle costing techniques and models. AFIT Report Number SLSR 18-74B, AD-787183. Wright-Patterson AFB, OH: Air Force Institute of Technology, August 1974. .
- Dunham, A. D. Estimated cost of on-the-job training to the 3-skill level in the communications center operations specialty. AFHRL-TR-72-56. AD-753 093. Lackland Air Force Base, Texas: Personnel Research Division, Air Force Human Resources Laboratory, June 1972.

- Drake III, W. F., R. R. Fisher, J. R. Younger. Logistics composite model users reference guide. AFLC Report 70-1, AD-7033328. Wright-Patterson AFB, OH: Headquarters, Air Force Logistics Command, January 1970.
- Drake III, W. F.. Logistics composite model users reference guide update: 1970-1974 Enhancement. AFLC/ADDR Report 74-1, Wright-Patterson AFB, OH: Headquarters, Air Force Logistics Command, November 1974.
- Engel, H. E., J. M. Glasier, R. A. Dowd, M. A. Bristol, H. A. Baran, and D. L. Dieterly. Digital avionics information system (DAIS): Current maintenance task analysis. AFHRL-TR-76-71, Wright-Patterson AFB, OH: Advanced Systems Division, Air Force Human Resources Laboratory, October 1976. (AD-A035 002)
- Fiorello, M. Estimating life-cycle costs: A case study of the A-7D. Rand Corporation, R-1518-PR, February 1975.
- Gates, R. K., M. J. Abraham. Program LCC documentation-version 2. TR-474-3, Wright-Patterson AFB, OH: Aeronautical Systems Division, Air Force Systems Command, 28 April 1976.
- Goclowski, J.C., A.J. LoFaso, S.E. Peskoe, H.A. Baran, Air Force personnel availability analysis: Program description for the personnel availability model. AFHRL-TR-79-68. Wright-Patterson AFB, OH: Logistics and Technical Training Division, Air Force Human Resources Laboratory, August 1980. (AD-A088 800)
- Goclowski, J. C., G. F. King, P. G. Ronco. Integration and application of human resource technologies in weapon system design: Processes for the coordinated application of five human resource technologies. AFHRL-TR-78-6 (II), Wright-Patterson AFB, OH: Advanced Systems Division, Air Force Human Resources Laboratory, March 1978. (AD-A053 681)
- Goclowski, J.C., & H.A. Baran, Digital avionics information system (DAIS): Life cycle cost impact modeling system (LCCIM)--A managerial overview. AFHRL-TR-79-64. Wright-Patterson AFB, OH: Logistics and Technical Training Division, Air Force Human Resources Laboratory, November 1980. (AD-A093 281)
- Goclowski, J.C., J.M. Glasier, R.H. Kistler, M.A. Bristol, H.A. Baran. Digital avionics information system (DAIS): Life cycle cost impact modeling system reliability, maintainability, and cost model (RMCM)--Description users guide. AFHRL-TR-79-65. Wright-Patterson AFB, OH: Logistics and Technical Training Division, Air Force Human Resources Laboratory, August 1980. (AD-A089 045)

- Graver, C. A., E. E. Balkovich, W. M. Carriere, R. Thibodean. Cost report elements and activity cost tradeoffs for defense system software. GRC Report #CR-1-721. General Research Corp., Santa Barbara, CA, November 1976.
- Hardy, C. A. Avionic reliability and life cycle cost partnership. AD/A-023 671, General Dynamics Corporation, 1975.
- Hicks, V. B., D. C. Tetmeyer. Simulating maintenance manning for new weapon systems: Data base management programs. AFHRL-TR-74-97(IV), AD-A011989. Wright-Patterson AFB, OH: Advanced Systems Division, Air Force Human Resources Laboratory, December 1974.
- Logistics support cost model user's handbook. Wright-Patterson AFB, OH: Air Force Logistics Command, June 1975.
- Mackenzie, W. D. Avionics information system life cycle cost model. Mechanics Research Inc., August 14, 1973.
- Moher, F. A., M. L. York. Simulating maintenance manning for new weapon systems: Maintenance manpower management during weapon system development. AFHRL-TR-74-97 (I). AD-A011986. Wright-Patterson AFB, OH: Advanced Systems Division, Air Force Human Resources Laboratory, December 1974.
- Management data lists of all federal stock catalog classes, FSC number ML-AF. Defense Logistics Agency, Battle Creeke, Michigan, July 1976.
- Military Standard 721B, Definitions for effectiveness terms for reliability, maintainability, human factors, and safety. 25 August 1966.
- Model A-7D integrated configuration list for aircraft serial numbers AF68-8220, AF68-8225 through AF68-8321, and AF69-6188 through AF69-6244, 2-51140/9R-8252; Vought Aeronautics Division, LTV Aerospace Corporation, February 1, 1971.
- Moody, W. D., D. C. Tetmeyer, S. R. Nichols. Simulating maintenance manning for new weapon systems: Manpower programs. AFHRL-TR-74-97 (V), AD-A011990. Wright-Patterson AFB, OH: Advanced Systems Division, Air Force Human Resources Laboratory, December 1974.
- Nelson, J. R., P. K. Dey, M. R. Fiorello, J. R. Gebman, G. K. Smith, A. Sweetland. A weapon-system life cycle overview: The A-7D experience. R-1452-PR, Rand Corporation, October 1974.
- Personnel procurement cost report. RCS: DD-M(SA)946. 1 July 1976 - September 1976.

Reel, R. E., C. E. Totey, W. L. Johnson. Weapon system support cost reduction study. AD527 245L, ASD/XR 72-49, Wright-Patterson AFB, OH: Aeronautical Systems Division, ASD/XRV. June 1972.

Samers, B.N., A.D. Dunham, F. Nordhauser. The development of a methodology for estimating the cost of Air Force on-the-job training. AFHRL-TR-74-34. Lackland Air Force Base, Texas: Manpower and Personnel Systems Division, Air Force Human Resources Laboratory, July 1974. (AD-785 141)

System specification for the digital avionics information system. SA 100 100A. Wright-Patterson AFB, OH: Systems Avionics Division, DAIS Advanced Development Program Office, July 1977.

Tetmeyer, D. C., W. D. Moody. Simulating maintenance manning for new weapon systems: Building and operating a simulation model. AFHRL-TR-74-97 (II), Wright-Patterson AFB, OH: Advanced Systems Division, Air Force Human Resources Laboratory, December 1974. (AD-A011 987)

Tetmeyer, D. C., S. R. Nichols, R. N. Deem. Simulating maintenance manning for new weapon systems: Maintenance data analysis program. AFHRL-TR-74-97 (III), AD-A025342. Wright-Patterson AFB, OH: Advanced Systems Division, Air Force Human Resources Laboratory, December 1975.

Training course cost report. RCS:HAF-ACM(A)7108.

Trainor, W. L. Analysis of DAIS mission software (MS) costs. DAIS Software Report #4. Wright-Patterson AFB, OH: Systems Avionics Division, DAIS Advanced Development Program Office, August 1974.

USAF, Air Force Regulation 173-10, Volume I. Cost analysis: USAF cost and planning factors (U). 4 September 1976.

Vendt, B. A. Software support for the F-16 avionics computers Air Force Institute of Technology, Wright-Patterson AFB, OH, December 1975. AD-A020361.

Wolverton, R. W. The cost of developing large-scale software. IEEE Transactions on Computers, Vol. C-23, No. 6, June 1974.

ACRONYMS

AFAL	Air Force avionics laboratory
AFSC	Air Force specialty codes
BCIU	bus control interface unit
BITE	built-in test equipment
CAS	close-air-support
CER	cost estimating relationship
CITS	central integrated test system
CND	cannot duplicate discrepancy
DAIS	digital avionics information system
DISPs	display processes
ECM	electronic countermeasures
EQUIPs	equipment processes
IMA	intermediate maintenance activity
LCC	life cycle cost
LCCIM	life cycle cost impact model
LCOM	logistics composite model
LRU	line replaceable unit
LSC	logistics support cost
MFHBMA	mean flight-hours between maintenance actions
MMH/FH	maintenance manhours per flight-hour
MTTR	mean time to repair
MUX	multiplex
NRC	nonrecurring costs
OFF	operational flight program
OPS	operational sequencers
OTP	operational test program
PALEFAC	partitioning, analyzing, and link editing facility
PBFH	peak base flying hours
RC	recurring costs
R&D	research and development
R&M	reliability and maintainability
RMCM	reliability, maintainability, cost model
ROC	required operational capability
RTU	remote terminal unit
SDVS	software design and verification system
SE	support equipment
SPEC	specialist functions
SRU	shop replaceable unit
TRAMOD	training requirements analysis model
WSAP	weapon system acquisition process

GLOSSARY OF COST ELEMENTS

CDP	cost of system disposal
CDR	cost of depot maintenance
CDRI	cost of initial depot support equipment
CFAI	cost of new or additional facilities
CFL	cost of fuel
CIM	cost of inventory management
CIMI	cost of inventory management initial
CJG	cost of supporting maintenance manuals
CJGI	cost of initial maintenance manuals
CO	cost of operation
COI	cost of support investment
COM	cost of on-equipment maintenance
COP	cost of operations personnel
CPM	cost of project management
CPP	cost of procurement
CPT	cost of maintenance personnel training
CPTI	cost of initial maintenance personnel training
CRD	cost of research and development
CS	cost of support
CSE	cost of maintaining support equipment
CSEI	cost of base level support equipment investment
CSI	cost of system investment
CSM	cost of intermediate shop maintenance
CSP	cost of replacement spares
CSPI	cost of spares investment
CSW	cost of software support
CSWI	cost of software acquisition