



# International Journal of Educational Methodology

Volume 10, Issue 1, 951 – 963.

ISSN: 2469-9632  
<https://www.ijem.com/>

## Boosting Students' Entrepreneurial Career Choices through the Role of Community Support: Evidence from Structural Equation Modeling

Maisyaroh\* 

Universitas Negeri Malang,  
INDONESIA

Juharyanto 

Universitas Negeri Malang,  
INDONESIA

Maulana Amirul Adha 

Universitas Negeri Jakarta,  
INDONESIA

Abdullah Mohd

Nawi   
Universiti Teknologi  
Malaysia, MALAYSIA

Received: September 8, 2023 • Revised: November 22, 2023 • Accepted: December 11, 2023

**Abstract:** Increasing the number of entrepreneurs is not just a school task, it requires joint work between educational institutions and the community. Using structural equation modeling, this research aims to investigate the role of community in promoting entrepreneurial careers for students, by adding achievement motivation, entrepreneurial attitudes, and entrepreneurial intentions as predictor variables. The population of this research was high school students in urban areas, and the sample was taken based on convenience sampling, with a total of 300 students participating. Data were analyzed using EFA, CFA, and structural model evaluation using SPSS 24.0 and AMOS 24.0. The research results show that all hypotheses are accepted, meaning that community support influences students' entrepreneurial career choices, as do other predictor variables. This study can provide guidance for developing educational strategies and policies that support the development of young entrepreneurs in the future, through predictor variables.

**Keywords:** *Achievement motivation, community support, entrepreneurial attitudes, entrepreneurial career choices, entrepreneurial intentions.*

**To cite this article:** Maisyaroh, Juharyanto, Adha, M. A., & Nawi, A. M. (2024). Boosting students' entrepreneurial career choices through the role of community support: Evidence from structural equation modeling. *International Journal of Educational Methodology*, 10(1), 951-963. <https://doi.org/10.12973/ijem.10.1.951>

### Introduction

In the era of globalization and constant change, career choice has become crucial in individual lives, especially for students who are determining the direction of their future (Engel et al., 2017; Ng et al., 2017). One career option that is increasingly attracting attention is becoming an entrepreneur (Adha et al., 2022; Costa et al., 2016). Entrepreneurs, as agents of economic and social change, have an important role in advancing community and creating new jobs. This is due to the problem of unemployment in every country in the world, including Indonesia. Quoting data released by the Indonesian Central Statistics Agency, until February 2022, people with a high school education were the top contributors to the unemployment rate. This becomes reasonable if it is related to the meaning of high school as a secondary level of education designed to prepare students to continue on to higher education. However, in reality, not all high school graduates continue to higher education and do not have sufficient skills to face challenges in the community (Haasler, 2020; Kvasková et al., 2023). One of the causes is a lack of skills and knowledge in entrepreneurship and a mindset that is oriented towards being an employee or job seeker. Therefore, understanding the factors that influence students in choosing entrepreneurship as a career choice is urgent.

Entrepreneurship has been promoted as a smart career choice among students around the world (Costa et al., 2016; Kallas, 2019; Memon et al., 2015), this trend is also occurring in Indonesia. This is also a concern for the government through the Project for Strengthening the Profile of *Pancasila* (the Five Principles, the Indonesian State Ideology) Students (*P5*), which is part of the Independent Learning Curriculum. Where one of the emphasis is on entrepreneurship. Since the independent learning policy was initiated, students have continued to explore the independent learning curriculum in every lesson (Christanti & Sukoco, 2022; Maisyaroh et al., 2021). Various good practices in supporting the project are also carried out by many school mover (Hadian et al., 2022; Rondli, 2022). The School Mover Program is an

---

#### \* Corresponding author:

Maisyaroh, Universitas Negeri Malang, Indonesia. ✉ [maisyaroh.fip@um.ac.id](mailto:maisyaroh.fip@um.ac.id)

initiative aimed at achieving the vision of Indonesian Education in the pursuit of an advanced Indonesia that is characterized by sovereignty, independence, and has personality.

Increasing the number of entrepreneurs is a joint task of the government, educational institutions and the community (Maisyaroh et al., 2019; Nowiński & Haddoud, 2019; Setiawan et al., 2021). Factors that influence intention in entrepreneurship, which in turn can affect students' career choices, namely the role of the community in supporting school entrepreneurship programs (Anjum et al., 2023; Callanan & Zimmerman, 2016; Lyu et al., 2023). Nowiński and Haddoud (2019) confirms that one of the roles of community can be seen as a role model and significantly influences intention in entrepreneurship. Communities can play a role in the education process, share knowledge and experience which can ultimately increase entrepreneurial motivation and improve student business performance (Adha et al., 2023; Juharyanto et al., 2023; Khan et al., 2021).

The role of the community is believed to influence students' intention in entrepreneurship and career choices, but this depends on motivation and attitudes as determinants of intention (Bazan, 2022; Boldureanu et al., 2020; Ghasemi et al., 2011). Some previous research conceptualize attitude and achievement motivation as factors that also influence students' entrepreneurial intentions and career choices (St-Jean & Mathieu., 2015; Wiyono & Wu., 2022). For examples research by Ghasemi et al. (2011); Maisyaroh et al. (2020) which shows the community support being able to influence entrepreneurial intention and career choices, through achievement motivation and entrepreneurship attitudes (Aggarwal & Shrivastava., 2021; Anjum et al., 2023).

Studies related to the role of community in efforts to increase intention in encouraging career choices as entrepreneurs have been widely studied by scholars (Anjum et al., 2023; Setiawan et al., 2021). One effort to create new entrepreneurs in graduates is by growing graduates' intention and awareness of entrepreneurship, because refers to the TPB (theory of planned behavior) put forward by Ajzen (1991) that intention in entrepreneurship is the best predictor that influences entrepreneurial behavior. Although there has been a lot of research that examines models that can be used to promote entrepreneurial careers, there is still not much that examines the role of community in efforts to increase students' intention in entrepreneurship in encouraging entrepreneurial career choices. For instance, research by Khan et al. (2021) examines the role of community support as a factor that influences entrepreneurial intention, but does not examine other variables. Meanwhile Pérez-Pérez et al. (2021) in their study explained that the communities can shape students' positive attitudes towards entrepreneurship which in turn encourages students to choose an entrepreneurial career. This study attempts to fill a void in previous research, namely trying to examine in depth the role of community in encouraging entrepreneurship as a career choice for students through a quantitative approach to investigate the contribution of factors the role of community in intention in entrepreneurship and students' career choices as entrepreneurs by including achievement motivation and attitudes towards entrepreneurship as predictor variables. It is hoped that the findings from this research will provide a deeper understanding of the factors that encourage students to choose career as entrepreneurship. The findings of this research can also provide guidance for educational policy makers, schools and community in supporting the development of entrepreneurship among students.

## Literature Review

### *Community Support*

The role of community in shaping individuals' thinking and behavior has received increasing attention in the social psychology literature (Eesley & Wang, 2017; Fong et al., 2018). According to Hyclak and Barakat (2010); and Maritz et al. (2022), communities serve as social environments that offer examples, beliefs, and norms that might affect students' decisions regarding their professional paths. Students can hone their entrepreneurial talents and contribute to the societal and economic advancement of their communities with the right kind of continued support. In psychology, education, and management studies, topics like achievement motivation, entrepreneurial attitudes, intentions, and students' career decisions as entrepreneurs are becoming more and more important (Asante et al., 2022; Ghasemi et al., 2011; Lindh, 2017; Otrachshenko et al., 2022; Schoenfeld et al., 2017; Taniguchi & Hirakawa, 2016).

The impact of community on the formation and impact of these factors has been a significant focal point in relevant scholarly investigations. According to a study conducted by Fong et al. (2018), there is evidence to suggest that the presence of a community might have an impact on an individual's degree of motivation towards achieving their goals. This assertion is further substantiated by the findings of Butler-Barnes et al. (2011), who discovered that entrepreneurial attitudes can be shaped by the impact of the social and cultural environment. Research suggests that individuals in their early years, are more likely to develop good entrepreneurial attitudes in societies that promote risk-taking, creativity, and independence (Agarwal et al., 2020; Loveridge et al., 2012). Study by Hockerts (2018) explained the effect of the community, such as the role of parents and successful entrepreneurs in the community, can influence students' entrepreneurial intentions. The availability of positive role models and social support in the community environment can increase students' intentions to engage in entrepreneurship (Eesley & Wang, 2017; Khan et al., 2021). Research by Banu and Baral (2022) shows that students who are exposed to an environment that supports entrepreneurship in the community are more likely to choose a career as an entrepreneur. In this context, the role of the community in creating

an environment that supports entrepreneurship is very important (Chang & Chen, 2020; Kallas, 2019). Based on this explanation, hypotheses 1, 2, and 3 are as follows:

H1: CS has an affect on AM

H2: CS has an affect on EA

H3: CS has an affect on EI

H4: CS has an affect on ECC

#### *Achievement Motivation*

Achievement motivation is an intrinsic or extrinsic drive that drives individuals to achieve goals that reflect achievement or excellence in various fields, including entrepreneurship (Adha et al., 2023; Ghasemi et al., 2011). Some studies have investigated the correlation between achievement motivation and entrepreneurial intention (Barba-Sánchez & Atienza-Sahuquillo, 2012; Sabiu et al., 2018). One common finding is that students who have high levels of achievement motivation tend to have higher intentions to become entrepreneurs. For example, research by Heydari et al. (2013) found that achievement motivation positively and significantly influences entrepreneurial intentions in university students. Similar results were also found in research by Wiyono and Wu (2022), which shows that achievement motivation has a positive influence on entrepreneurial intentions among students. In addition to influencing entrepreneurial intentions, achievement motivation can also influence one's career choices. Students as a graduate candidate with high achievement motivation may tend to choose careers as entrepreneurs rather than being employees who depend on other companies (Ghasemi et al., 2011; Mukesh et al., 2021). Research by Chang and Chen (2020) shows that achievement motivation can be an important predictor in choosing a career as an entrepreneur, individuals who have a high achievement motivation have a tendency to start their own business. Hence, the fifth and sixth hypotheses in this study are as follows:

H5: AM has an affect on EI

H6: AM has an affect on ECC

#### *Entrepreneurial Attitudes*

Entrepreneurial attitudes refers to the views and behavior of individuals related to entrepreneurship. Entrepreneurial attitude is a psychological dimension that plays a key role in predicting students' intention in entrepreneurship (Hassi, 2016; Wongnaa & Seyram, 2014). Empirical research has shown that a positive entrepreneurial attitude can increase one's entrepreneurial intentions (Hou et al., 2019; Wang & Huang, 2022). Students who have a good entrepreneurial attitudes tend to be more confident in developing their own business. Career choice as an entrepreneur refers to an individual's decision to pursue a career as a business owner or entrepreneur. Entrepreneurial attitudes can play an important role in determining this career choice (Loveridge et al., 2012; Maritz et al., 2021). Individuals with strong entrepreneurial attitudes tend to be more likely to choose to become entrepreneurs rather than seek traditional employment (St-Jean & Mathieu, 2015). Hence, the seventh and eighth hypotheses in this study are as follows:

H7: EA has an affect on EI

H8: EA has an affect on ECC

#### *Entrepreneurial Intentions*

Entrepreneurial intention refers to a student's tendency to want to start and develop their own business venture (Hirschi, 2013). Ajzen (1991) introduced a significant theoretical framework known as TPB (Theory of Planned Behavior). According to this view, the primary determinant of entrepreneurial action is the intention entrepreneurial. Put simply, those with a greater intention towards entrepreneurship are more inclined to pursue a professional path as entrepreneurs. In addition, the current literature has also proven a positive and significant relationship between EI and ECC (Adha et al., 2022; Costa et al., 2016; Tsordia & Papadimitriou, 2015). Therefore, hypotheses 9 in this study are:

H9: EI has an affect on ECC.

## **Methodology**

### *Research Design*

In order to determine the characteristics that drive students in Indonesia to pursue careers in business on their own, a quantitative technique employing SEM has been utilized in this research. In accordance with the research objectives and research design chosen, this research uses a positivist philosophical approach. Studies from previous research were used to establish the context of the relationships between variables in this study (Adha et al., 2022; Eesley & Wang, 2017; Fong et al., 2018; Heydari et al., 2013; Hirschi, 2013; Hockerts, 2018).

### *Participants and Data Collection*

The research population includes high school students in the Jakarta Province area, who are classified as school movers. The School Mover program is an initiative by the Indonesian government that seeks to expedite the advancement of public and private schools across all educational levels by 1-2 steps. The primary objective of the school mover program is to foster holistic student learning outcomes, encompassing both proficiency in literacy and numeracy as well as character development. This initiative places a strong emphasis on cultivating exceptional human resources as the foundation for achieving these goals. The sample was taken based on convenience sampling, based on recommendations Nunnally (1978), the appropriate sample size should be above or close to 300 to prevent bias and error. Therefore, a total of 350 questionnaires were distributed to the four senior high schools that were included in the school mover program in the Jakarta area. Data for this research was collected from the period May 2023 to July 2023. A total of 350 respondents were closed, 300 of which were filled in correctly and used for data processing. More detailed demographic data of respondents are as follows; (a) Gender, male: 128 (42.7%) and female: 172 (57.3%); (b) Grade level, 10th: 64 (21.3%), 11th: 132 (44.0%), and 12th: 104 (34.7%); (c) Parents' job, civil servants: 78 (26.0%), private employees: 94 (31.3%), military/police: 66 (22.0%), and entrepreneur: 62 (20.7%); and (d) Parents' education level, high school: 97 (32.3%), diploma: 52 (17.3%), bachelor: 107 (35.7%), master: 29 (9.7%), and doctoral: 15 (5.0%).

The questionnaire as the main research instrument in this study was designed by the researcher after conducting an extensive review of the existing literature. The community support questionnaire (4 indicators) was adopted from research by Eesley and Wang (2017); Hockerts (2018), which includes indicators such as, (a) access to capital, (b) access to information, (c) social networks, and (d) attitudes and community support. Achievement motivation (3 indicators) was adopted from research by Karaman and Smith (2019), which includes indicators (a) need for achievement, (b) need for affiliation, and (c) need for power. Three indicators were used for the entrepreneurial attitudes questionnaire adopted from Liñán and Chen (2009) study, namely (a) attitudes toward achievement, (b) attitudes toward autonomy, and (c) attitudes toward challenges. The EI measurement scale (3 indicators) adapted on the basis of indicators established by Liñán and Chen (2009) including (a) desire, (b) interest, and (c) belief. The measurement scale for ECC (4 items) was adapted from indicators developed by Tiedeman and O'Hara (1963); which was also adapted by Goh and Jamaluddin (2021), namely exploration, crystallization, selection and clarification. This research uses a 4 point Likert type scale and a total of 19 items in the questionnaire is translated into Indonesian which had been checked by experts so that it is easy for respondents to understand. After the school and teacher give permission, students are invited to fill out the questionnaire in the field. Respondents were introduced to the purpose of the study and the importance of their responses. Participants were informed that there was no definitive correct or incorrect answers, and that all provided responses would be valued and acknowledged. Moreover, survey participation is voluntary, and opinions are anonymous so that only the researcher knows the identity of the respondent (MacKenzie & Podsakoff, 2012). To ensure the questionnaire was valid and reliable, exploratory factor analysis was carried out with the help of SPSS 24.0.

### *Data Analysis*

The analysis employed structural equation modeling (SEM) as the chosen methodology. Prior to employing SEM to test the proposed hypothesis, an initial exploratory factor analysis (EFA) and subsequently a confirmatory factor analysis (CFA) in order to establish the psychometric soundness of the survey concept (Byrne, 2016; Schumaker & Lomax, 2010). The statistical analysis involved the utilization of AMOS 24.0 software to analyze CFA and evaluate the research model, and SPSS 24.0 software to conduct EFA. Before analyzing SEM models, perform a comprehensive assumption test. The normality test shows that each indicator's skewness and kurtosis critical ratio (c.r) is less than  $\pm 2.58$ . Meanwhile, the multivariate kurtosis line has  $c.r = 2.426$ . As proposed by Byrne (2016), this shows that the data is normal at both the univariate and multivariate levels. The outlier test was then performed according to Blunch (2013), which recommended a mahalanobis distance (MD) value less than chi square to suggest no multivariate outlier problem. The analysis showed a chi-square value of 263.823 and a most significant MD value of 165.731.

## **Results**

### *Exploratory Factor Analysis*

The present study utilized corrected item total correlations ( $r$ ) to enhance the selected items of the scale. This analysis aids in the elimination of inconsequential elements that may potentially impact the outcomes of exploratory factor analysis (EFA). As a result, all the items in the dataset had coefficients fixed at the recommended value of 0.40, as reported by Hair et al. (2016) and displayed in Table 1. Furthermore, in order to uphold the internal consistency and validity of the constructs under investigation, we employed Cronbach's alpha with a minimum acceptable level of 0.70 (Blunch, 2013). Nevertheless, all the research constructions' coefficients surpass the predetermined threshold, and the outcomes are presented in Table 1. Furthermore, the Skewness and Kurtosis values for each item fell between the range of +2 to -2, as reported by Cain et al. (2017) and Uslu and Arslan (2017) and displayed in Table 1. These findings suggest that all of the selected items exhibited a normal distribution. In addition, Kaiser-Meyer-Olkin (KMO) conducted to test of sample adequacy and Bartlett's test of sphericity to determine the appropriateness of performing EFA on the gathered data. According to the findings presented in Table 1, KMO value for the dataset exceeded the threshold of 0.60, the results

suggest that the data exhibited sufficient suitability for factor analysis (Hair et al., 2016; Tabachnick & Fidell, 2007). Bartlett's test of sphericity yielded a p-value of less than 0.005, further supporting the appropriateness of doing factor analysis on the dataset.

Table 1. Results of Exploratory Factor Analysis

Factor	Eigen Values	Explained Varianced (%)	r	$\alpha$	BTS (p)	KMO
Community Support	7.349	22.244	0.591 – 0.722	0.837	248.708 (0.000)	0.817
Achievement Motivation	3.251	13.891	0.733 – 0.885	0.882	359.140 (0.000)	0.864
Entrepreneurial Attitude	2.163	10.073	0.549 – 0.798	0.864	276.819 (0.000)	0.831
Entrepreneurial Intentions	1.570	7.510	0.706 – 0.842	0.911	431.533 (0.000)	0.886
Entrepreneurial Career Choices	1.348	6.127	0.628 – 0.754	0.906	305.952 (0.000)	0.849

In this study, all of the measuring scales were self-reported, so we conducted a variety of tests to investigate the possibility of common method variance. In the beginning, it started by conducting an exploratory factor analysis in SPSS. This involved simultaneously loading all of the items from each construct in order to establish the minimum number of factors required to adequately explain the variables' variance. The results of the factor analysis revealed the existence of five factors, each of which had eigenvalues greater than 1.0. It appears that the common technique bias is not an issue in this study (Podsakoff et al., 2012), as the five separate factors accounted for 59.85% of the total variance, and the first largest component accounted for 22.24% (less than 50%).

#### Confirmatory Factor Analysis

The assessment of the measuring model's validity was performed by the implementation of confirmatory factor analysis (CFA) on all sets of constructs. Therefore, the fit indices of the CFA, presented in Table 2 have met the established criterion, as suggested by Kline (2016); and Hu and Bentler (1999), namely CFI = 0.952; GFI= 0.921; SRMR = 0.042; RMSEA = 0.050; TLI = 0.939; and CMIN/df = 2.217.

Table 2. Goodness of Fit Indices

Fit Indices	Probability	CFI	GFI	RMSEA	SRMR	TLI	CMIN/df
Cut of Value	> 0.050	> 0.900	> 0.900	< 0.080	< 0.080	> 0.900	< 3.000
Measured	0.058	0.952	0.921	0.050	0.042	0.939	2.217
Label	Good	Good	Good	Good	Good	Good	Good

Nevertheless, it is worth noting that all of the loading factors presented in Table 3 exceeded the threshold of 0.50, as reported by Hair et al. (2016). In order to validate the reliability estimates, the researchers conducted a composite reliability analysis, which revealed that all constructs exhibited values exceeding 0.70, as reported by Hair et al. (2016). The findings of this study indicate that it is possible to establish the convergent validity. Furthermore, in order to establish the convergent validity, the researchers also computed the average variance explained (AVE), which was found to above the criterion of 0.50 for all values (Bagozzi & Yi, 1988).

Table 3. Results of Convergent Validity

Construct	Item Code	Loading	AVE	CR
Community Support (CS)			0.62	0.90
	CS1	0.83		
	CS2	0.80		
	CS3	0.78		
Achievement Motivation (AM)	CS4	0.90		
			0.59	0.81
	AM1	0.71		
	AM2	0.85		
Entrepreneurial Attitude (EA)	AM3	0.73		
			0.67	0.86
	EA1	0.77		
	EA2	0.86		
	EA3	0.82		

Table 3. Continued

Construct	Item Code	Loading	AVE	CR
Entrepreneurial Intentions (EI)	EI1	0.84	0.65	0.85
	EI2	0.86		
	EI3	0.72		
Entrepreneurial Career Choices (ECC)	ECC1	0.74	0.64	0.88
	ECC2	0.86		
	ECC3	0.77		
	ECC4	0.82		

Discriminant validity is a measure that examines the extent of comprehension by considering diverse signs associated with several concepts (Bagozzi & Yi, 1988). According to Hair et al. (2016), the interrelationship between elements inside structures is limited to the square root of the average variance shared by one of the structures. It can be seen from Table 4 that the square root of the AVE has a greater value for all variables when compared to the correlation coefficients that are associated with those variables. This finding lends credence to the notion that discriminant validity has been demonstrated.

Table 4. Results of Discriminant Validity

Construct	CS	AM	EA	EI	ECC
Community Support (CS)	<b>0.789</b>				
Achievement Motivation (AM)	0.438	<b>0.766</b>			
Entrepreneurial Attitude (EA)	0.235	0.117	<b>0.817</b>		
Entrepreneurial Intentions (EI)	0.412	0.388	0.203	<b>0.809</b>	
Entrepreneurial Career Choices (ECC)	0.155	0.361	0.179	0.214	<b>0.799</b>

Structural Model Analysis

The findings presented in Figure 1 and Table 5 provide evidence of a statistically significant relationship between the variables CS and AM ( $\beta = 0.23, p = 0.01$ ). This correlation supports the first hypothesis (H1) and indicates a positive and substantial relationship between the two variables. The subsequent impact demonstrates a noteworthy and positive association between the CS and EA, supporting the second hypothesis (H2) ( $\beta = 0.31, p = 0.00$ ). The findings of this study also reveal a statistically significant positive correlation ( $\beta = 0.34, p = 0.00$ ) between CS and EI, providing support for the third hypothesis (H3). Moreover, the statistical analysis reveals a substantial positive correlation ( $\beta = 0.25, p = 0.01$ ) between CS and ECC, supporting the fourth hypothesis (H4). In the present study, participants expressed the viewpoint that CS had a positive impact on various aspects, namely AM, EA, EI and ECC.

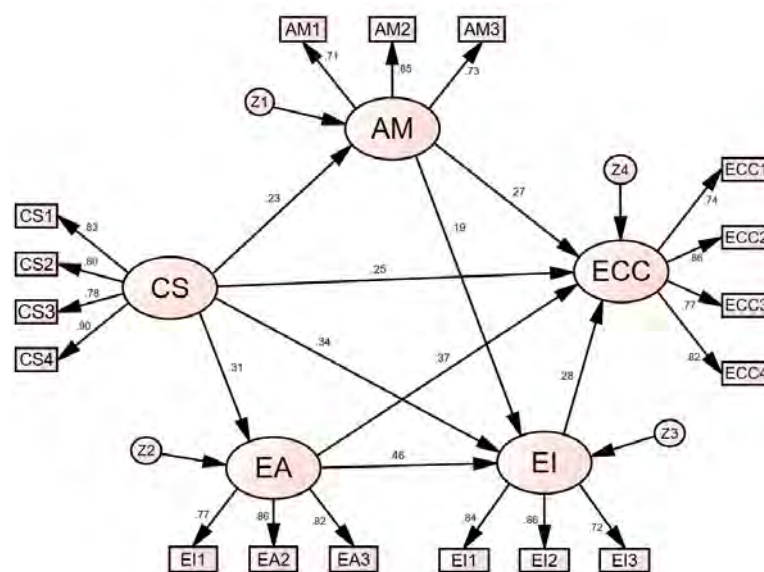

Figure 1. Results of Structural Model

Furthermore, the findings of this study reveal a statistically significant positive correlation ( $\beta = 0.19, p = 0.02$ ) between the variables of AM and EI, providing support for the fifth hypothesis (H5). In addition to the aforementioned findings, the statistical analysis reveals a substantial positive correlation ( $\beta = 0.27, p = 0.00$ ) between AM and ECC, supporting the

sixth hypothesis (H6). The seventh hypothesis (H7) demonstrates a positive and statistically significant correlation between EA and EI ( $\beta = 0.46, p = 0.00$ ). The findings of this study reveal a statistically significant positive correlation ( $\beta = 0.37, p = 0.00$ ) between EA and ECC, providing support for the eighth hypothesis (H8). Moreover, the results indicate a positive and statistically significant correlation ( $\beta = 0.28, p = 0.00$ ) between EI and ECC, supporting the ninth hypothesis (H9).

Table 5. Results of Hypotheses Testing

Path	$\beta$	p	Cut of Value	Decision
CS → AM	0.23	0.01	0.05	H1 Supported
CS → EA	0.31	0.00	0.05	H2 Supported
CS → EI	0.34	0.00	0.05	H3 Supported
CS → ECC	0.25	0.01	0.05	H4 Supported
AM → EI	0.19	0.02	0.05	H5 Supported
AM → ECC	0.27	0.00	0.05	H6 Supported
EA → EI	0.46	0.00	0.05	H7 Supported
EA → ECC	0.37	0.00	0.05	H8 Supported
EI → ECC	0.28	0.00	0.05	H9 Supported

### Discussion

Using structural equation modeling, this research aims to investigate the role of community, achievement motivation, entrepreneurial attitudes, and entrepreneurial intentions in promoting entrepreneurial careers for high school students. The option of pursuing a profession as an entrepreneur holds considerable appeal for several individuals in the contemporary age of globalization and information technology (Adha et al., 2022; Chang & Chen, 2020). The achievement of an entrepreneur is contingent upon not only their proficiency in business knowledge and abilities, but also their psychological and social elements (Bazan, 2022; Tantawy et al., 2021). The findings of this study demonstrate that community support, achievement motivation, entrepreneurial attitudes, and entrepreneurial intentions have a significant influence on student's career decision to pursue entrepreneurship. The provision of community support, encompassing expressions of gratitude, commendation, and motivation from those within one's social network, including friends, neighbors, and the local community, has been investigated as a significant factor in fostering students' drive to achieve academic excellence (Fong et al., 2018; Roundy, 2022; Taniguchi & Hirakawa, 2016). The provision of community support, namely through the celebration of student accomplishments, has the potential to enhance their self-confidence (Cook et al., 2016). When students see a sense of worth and appreciation from their community, it tends to enhance their motivation to attain higher levels of academic accomplishment. This exemplifies the impact of community support on students' drive to attain academic success. In addition, scholarly research conducted by Banu and Baral (2022); Wiyono and Wu (2022) suggests that community-based social support plays a significant role in assisting students in surmounting barriers and navigating problems encountered in the pursuit of their objectives. Supportive communities play a crucial role in facilitating the establishment of robust social networks for students, enabling them to readily access assistance and guidance when confronted with challenges. This can assist individuals in maintaining their motivation and persevering in the face of challenges.

Students' views about entrepreneurship can be shaped to a certain extent by the support of their communities in a number of different ways. First, according to Chang and Chen (2020), schools that foster an environment that promotes creativity, innovation, and an entrepreneurial spirit are more likely to produce graduates with good attitudes toward entrepreneurship. According to Cohen and Katz (2016); and Kim and Park (2019), when students are exposed to an atmosphere like this, they are more likely to recognize chances for business all around them and are more likely to feel at ease taking risks while operating their own businesses. Second, having support from the community can assist students in understanding the significance of entrepreneurship in the process of job creation and the expansion of the local economy (Loveridge et al., 2012). When local communities have a better understanding of the potential economic benefits that might be generated from local enterprises, they will be more supportive of students' efforts to become entrepreneurs.

Intentions of students to establish their own businesses are significantly affected by the support of the community (Eesley & Wang, 2017; Hockerts, 2018). The presence of supportive communities can serve as a catalyst for students' intention towards embarking on an entrepreneurial path. This research is in line with previous research, for instance, the exposure of students to accomplished entrepreneurs within their local community and the reception of motivational narratives regarding their entrepreneurial endeavors have been found to enhance their inclination towards adopting a similar career trajectory (Boldureanu et al., 2020; Memon et al., 2015). This study also complements the results of previous research, although many have highlighted the role of the community, but still many previous studies emphasize the influence of the family (Adha et al., 2023; Cook et al., 2016), while this study focuses more on relationships with practitioners or the business world. Furthermore, it has been shown that communities that offer resources and infrastructure to foster the development of entrepreneurial abilities have the potential to enhance students' intents

towards entrepreneurship (Baldo et al., 2023; Maisyarah et al., 2021). The provision of training, mentorship, and other essential resources to students enhances their likelihood of cultivating strong entrepreneurial intentions.

Communities that place importance on entrepreneurial careers and offer assistance to entrepreneurs within their locality can create avenues for students to pursue entrepreneurial professions (Agarwal et al., 2020; Banu & Baral, 2022). When students see that being an entrepreneur is a respected and valued option in their community, they are more likely to consider the career. In addition, community support can also influence students' decisions in terms of the resources they need to start their own business (Hockerts, 2018; Uysal et al., 2022). Communities that offer students opportunities to access venture capital, valuable information, and extensive business networks can enhance the appeal and feasibility of pursuing entrepreneurial career paths. Venture capital provides critical financial support that budding entrepreneurs often need to start and scale their ventures. Access to funding reduces financial barriers, enabling students to turn innovative ideas into viable businesses (Veleva & Bodkin, 2018). Access to information related to valuable market insights and industry trends allows students to better understand market needs and demands (Lyu et al., 2023). This information helps refine business ideas and strategies, increasing the chances of success. Extensive business networks create opportunities for collaboration, partnerships and synergies between students, entrepreneurs, investors and industry leaders (Eesley & Wang, 2017). Collaborative efforts often result in innovative solutions and greater market reach. The provision of community support can also aid students in surmounting the apprehension and ambiguity linked to embarking on an entrepreneurial path. Becoming an entrepreneur often entails substantial risks, and the provision of social support might enhance students' confidence and preparedness in confronting this formidable undertaking (Eesley & Wang, 2017; Kallas, 2019).

### Conclusion

The influence of the role of community support on achievement motivation, entrepreneurial attitudes, entrepreneurial intentions, and students' career choices as entrepreneurs is confirmed in this study, the results of this study certainly add new insights into the importance of the role of community in encouraging students to choose a career as an entrepreneur. Community support can motivate students to achieve higher, develop positive entrepreneurial attitudes, increase their entrepreneurial intentions, and make career choices as entrepreneurs more attractive. This adds to the knowledge that it is not only the role of family and entrepreneurship education that can encourage students to choose a career as an entrepreneur, furthermore schools can involve the community especially practitioners and local industries to contribute in promoting entrepreneurial careers. Community support can take the form of appreciation, recognition, training, access to information related to entrepreneurship or even the provision of financial resources. All of these forms of support can help students develop their potential as successful entrepreneurs, which in turn can make a positive contribution to economic growth and development of local communities.

### Recommendations

Based on the results of the study, practical recommendations are formulated for schools, namely the need to encourage and formulate programs such as guest teacher programs, training, the formation of entrepreneurial communities involving the community and business actors in supporting entrepreneurship development in schools that need to be improved to motivate students to choose careers as entrepreneurs. In addition, this research can provide guidance for developing educational strategies and policies that support the development of young entrepreneurs in the future. For future researchers, the recommendations formulated can use a qualitative research approach, in order to obtain in-depth information related to efforts to increase the role of community support in promoting student entrepreneurial careers, this information can be in the form of what programs can be implemented, how to effectively involve the community in school entrepreneurship activities and by considering the local social and cultural context, because community support can vary in various environments.

### Limitations

This research is also not free from several limitations, including: (1) Age of Respondents: This research only involved high school students, so the results may not be applicable to older or younger age groups; (2) Study population: The study findings may have limitations in terms of generalizability, as the study population was only high school students in urban areas, which may not be representative of remote areas; (3) Limitations in Measuring Community Support: Measuring community support may be subjective and can be interpreted in various ways by students.

### Ethics Statements

The studies involving human participants were reviewed and approved by Research and Community Service Institute (LP2M) of Universitas Negeri Malang, Indonesia. Survey participation is voluntary, and answers are anonymous so that only the researcher knows the identity of the respondent.

### Funding

This research was supported by the Directorate of Research, Technology, and Community Service (DRTPM) Ministry of Education, Culture, Research and Technology Republic of Indonesia, under Grant number 0557/E5.5/AL.04/2023.



## Authorship Contribution Statement

Maisyaroh: Conceptualization, drafting manuscript, statistical analysis, final approval. Juharyanto: Design, data collection, drafting manuscript. Adha: Data collection, statistical analysis, final approval. Nawi: Design, drafting manuscript, statistical analysis, editing/reviewing.

## References

- Adha, M. A., Eryanto, H., Ariyanti, N. S., Musadad, A. A., Musyaffi, A. M., & Wibowo, A. (2023). Evaluating the structural effect of family support and entrepreneurship training on entrepreneurship intention among Indonesian university students. *International Journal of Educational Methodology*, 9(1), 227–236. <https://doi.org/10.12973/ijem.9.1.227>
- Adha, M. A., Wibowo, A., Faslah, R., Ariyanti, N. S., & Lutfia, A. (2022). Students ideal career in the 4.0 industrial. *Journal of Eastern European and Central Asian Research*, 9(4), 651–664. <https://doi.org/10.15549/jeecar.v9i4.928>
- Agarwal, S., Ramadani, V., Gerguri-Rashiti, S., Agrawal, V., & Dixit, J. K. (2020). Inclusivity of entrepreneurship education on entrepreneurial attitude among young community: Evidence from India. *Journal of Enterprising Communities: People and Places in the Global Economy*, 14(2), 299–319. <https://doi.org/10.1108/JEC-03-2020-0024>
- Aggarwal, A., & Shrivastava, U. (2021). Entrepreneurship as a career choice: Impact of environment on high school students' intentions. *Education + Training*, 63(7/8), 1073–1091. <https://doi.org/10.1108/ET-07-2020-0206>
- Ajzen, I. (1991). The theory of planned behavior. *Organizational Behavior and Human Decision Processes*, 50(2), 179–211. [https://doi.org/10.1016/0749-5978\(91\)90020-T](https://doi.org/10.1016/0749-5978(91)90020-T)
- Anjum, T., Amoozegar, A., Farrukh, M., & Heidler, P. (2023). Entrepreneurial intentions among business students: The mediating role of attitude and the moderating role of university support. *Education + Training*, 65(4), 587–606. <https://doi.org/10.1108/ET-01-2021-0020>
- Asante, E. A., Danquah, B., Oduro, F., Affum-Osei, E., Ankrah Twumasi, M., Azunu, C., & Li, C. (2022). Entrepreneurial career persistence of hybrid entrepreneurs: The opposing moderating roles of wage work-to-entrepreneurship enrichment and entrepreneurship-to-wage work enrichment. *Journal of Vocational Behavior*, 132, Article 103660. <https://doi.org/10.1016/j.jvb.2021.103660>
- Bagozzi, R. P., & Yi, Y. (1988). On the evaluation of structural equation models. *Journal of the Academy of Marketing Science*, 16, 74–94. <https://doi.org/10.1007/BF02723327>
- Baldo, C. M., Chen McCain, S.-L., & Joufflas, G. (2023). An investigation on factors influencing university students' entrepreneurship orientations. *Entrepreneurship Education and Pedagogy*. Advance online publication. <https://doi.org/10.1177/25151274231184800>
- Banu, J., & Baral, R. (2022). Career choice, growth and well-being of women entrepreneurs' community: Insights on driving factors in India. *Journal of Enterprising Communities: People and Places in the Global Economy*, 16(5), 781–807. <https://doi.org/10.1108/JEC-12-2020-0206>
- Barba-Sánchez, V., & Atienza-Sahuquillo, C. (2012). Entrepreneurial behavior : Impact of motivation factors on decision to create a new venture. *Investigaciones Europeas de Dirección y Economía de La Empresa*, 18(2), 132–138. [https://doi.org/10.1016/S1135-2523\(12\)70003-5](https://doi.org/10.1016/S1135-2523(12)70003-5)
- Bazan, C. (2022). Effect of the university's environment and support system on subjective social norms as precursor of the entrepreneurial intention of students. *SAGE Open*, 12(4), 1–20. <https://doi.org/10.1177/21582440221129105>
- Blunch, N. J. (2013). *Introduction to structural equation modeling using IBM SPSS Statistics and AMOS*. Sage. <https://doi.org/10.4135/9781526402257>
- Boldureanu, G., Ionescu, A. M., Bercu, A.-M., Bedrule-Grigoruță, M. V., & Boldureanu, D. (2020). Entrepreneurship education through successful entrepreneurial models in higher education institutions. *Sustainability*, 12(3), Article 1267. <https://doi.org/10.3390/su12031267>
- Butler-Barnes, S. T., Chavous, T. M., & Zimmerman, M. A. (2011). Exposure to violence and achievement motivation beliefs: Moderating roles of cultural-ecological factors. *Race and Social Problems*, 3, 75–91. <https://doi.org/10.1007/s12552-011-9044-4>
- Byrne, B. M. (2016). *Structural equation modeling with AMOS: Basic concepts, applications, and programming* (3rd ed.). Routledge. <https://doi.org/10.4324/9781315757421>
- Cain, M. K., Zhang, Z., & Yuan, K.-H. (2017). Univariate and multivariate skewness and kurtosis for measuring nonnormality: Prevalence, influence and estimation. *Behavior Research Methods*, 49, 1716–1735. <https://doi.org/10.3758/s13428-016-0814-1>
- Callanan, G. A., & Zimmerman, M. (2016). To be or not to be an entrepreneur: Applying a normative model to career

- decisions. *Journal of Career Development*, 43(5), 447–461. <https://doi.org/10.1177/0894845316633525>
- Chang, Y.-Y., & Chen, M.-H. (2020). Creative entrepreneurs' creativity, opportunity recognition, and career success: Is resource availability a double-edged sword? *European Management Journal*, 38(5), 750–762. <https://doi.org/10.1016/j.emj.2020.03.004>
- Christanti, R., & Sukoco, A. A. (2022). Freedom to learn–independent campus policy: Do we really find our freedom? *Journal of Education and Learning*, 16(2), 189–198. <https://doi.org/10.11591/edulearn.v16i2.20477>
- Cohen, H., & Katz, H. (2016). Social entrepreneurs narrating their careers: A psychodynamic-existential perspective. *Australian Journal of Career Development*, 25(2), 78–88. <https://doi.org/10.1177/1038416216658046>
- Cook, A. L., Hayden, L. A., Bryan, J., & Belford, P. (2016). Implementation of a school-family-community partnership model to promote latina youth development: Reflections on the process and lessons learned. *International Journal of Research on Service-Learning and Community Engagement*, 4(1), 101–117. <https://doi.org/10.37333/001c.29609>
- Costa, S. F., Caetano, A., & Santos, S. C. (2016). Entrepreneurship as a career option: Do temporary workers have the competencies, intention and willingness to become entrepreneurs? *The Journal of Entrepreneurship*, 25(2), 129–154. <https://doi.org/10.1177/0971355716650363>
- Eesley, C., & Wang, Y. (2017). Social influence in career choice: Evidence from a randomized field experiment on entrepreneurial mentorship. *Research Policy*, 46(3), 636–650. <https://doi.org/10.1016/j.respol.2017.01.010>
- Engel, Y., van Burg, E., Kleijn, E., & Khapova, S. N. (2017). Past career in future thinking: How career management practices shape entrepreneurial decision making. *Strategic Entrepreneurship Journal*, 11(2), 122–144. <https://doi.org/10.1002/sej.1243>
- Fong, C. J., Acee, T. W., & Weinstein, C. E. (2018). A person-centered investigation of achievement motivation goals and correlates of community college student Achievement and persistence. *Journal of College Student Retention: Research, Theory and Practice*, 20(3), 369–387. <https://doi.org/10.1177/1521025116673374>
- Ghasemi, F., Rastegar, A., Jahromi, R. G., & Marvdashti, R. R. (2011). The relationship between creativity and achievement motivation with high school students' entrepreneurship. *Procedia - Social and Behavioral Sciences*, 30, 1291–1296. <https://doi.org/10.1016/j.sbspro.2011.10.250>
- Goh, M., & Jamaluddin, H. (2021). Influencers of university students' career decision. *Issues and Perspectives in Business and Social Sciences*, 1(1), 28–44. <https://doi.org/10.33093/ipbss.2021.1.4>
- Haasler, S. R. (2020). The German system of vocational education and training: Challenges of gender, academisation and the integration of low-achieving youth. *Transfer: European Review of Labour and Research*, 26(1), 57–71. <https://doi.org/10.1177/1024258919898115>
- Hadian, T., Mulyana, R., Mulyana, N., & Tejawiani, I. (2022). Implementasi project based learning penguatan profil pelajar pancasila di SMAN 1 Kota Sukabumi [Implementation of project based learning to strengthen the profile of Pancasila students at SMAN 1 Sukabumi City]. *Primary: Jurnal Pendidikan Guru Sekolah Dasar*, 11(6), 1659–1669. <https://doi.org/10.33578/jpkip.v11i6.9307>
- Hair, J. F., Black, W. C., Babin, B. J., & Anderson, R. E. (2016). *Multivariate data analysis* (8th ed.). Cengage Learning.
- Hassi, A. (2016). Effectiveness of early entrepreneurship education at the primary school level: Evidence from a field research in Morocco. *Citizenship, Social and Economics Education*, 15(2), 83–103. <https://doi.org/10.1177/2047173416650448>
- Heydari, H., Madani, D., & Rostami, M. (2013). The study of the relationships between achievement motive, innovation, ambiguity tolerance, self-efficacy, self-esteem, and Self-actualization, with the orientation of entrepreneurship in the Islamic Azad University of Khomein Students. *Procedia - Social and Behavioral Sciences*, 84, 820–826. <https://doi.org/10.1016/j.sbspro.2013.06.654>
- Hirschi, A. (2013). Career decision making, stability, and actualization of career intentions: The case of entrepreneurial intentions. *Journal of Career Assessment*, 21(4), 555–571. <https://doi.org/10.1177/1069072712475287>
- Hockerts, K. (2018). The effect of experiential social entrepreneurship education on intention formation in students. *Journal of Social Entrepreneurship*, 9(3), 234–256. <https://doi.org/10.1080/19420676.2018.1498377>
- Hou, F., Su, Y., Lu, M., & Qi, M. (2019). Model of the entrepreneurial intention of university students in the Pearl River Delta of China. *Frontiers in Psychology*, 10, Article 916. <https://doi.org/10.3389/fpsyg.2019.00916>
- Hu, L.-T., & Bentler, P. M. (1999). Cutoff criteria for fit indexes in covariance structure analysis: Conventional criteria versus new alternatives. *Structural Equation Modeling: A Multidisciplinary Journal*, 6(1), 1–55. <https://doi.org/10.1080/10705519909540118>

- Hyclak, T., & Barakat, S. (2010). Entrepreneurship education in an entrepreneurial community. *Industry and Higher Education*, 24(6), 475–486. <https://doi.org/10.5367/ihe.2010.0018>
- Juharyanto, J., Arifin, I., Sultoni, S., Adha, M. A., & Qureshi, M. I. (2023). Antecedents of primary school quality: The case of remote areas schools in Indonesia. *SAGE Open*, 13(1), 1–14. <https://doi.org/10.1177/21582440221144971>
- Kallas, E. (2019). Environment-readiness entrepreneurship intention model: The case of Estonians and the Russian-speaking minority in Estonia. *SAGE Open*, 9(1), 1–15. <https://doi.org/10.1177/2158244018821759>
- Karaman, M. A., & Smith, R. (2019). Turkish adaptation of achievement motivation measure. *International Journal of Progressive Education*, 15(5), 185–197. <https://doi.org/10.29329/ijpe.2019.212.13>
- Khan, M. F., Amin, F., & Khanday, N. (2021). Nurturing entrepreneurial intentions of students using virtual communities. In R. Sharma, S. Shukla, A.K. Dwivedi, & G. Batthini (Eds.), *Proceedings of Fourteenth Biennial Conference on Entrepreneurship* (pp. 1–13). Bookwell Delhi.
- Kim, M., & Park, M. J. (2019). Entrepreneurial education program motivations in shaping engineering students' entrepreneurial intention. *Journal of Entrepreneurship in Emerging Economies*, 11(3), 328–350. <https://doi.org/10.1108/JEEE-08-2018-0082>
- Kline, R. B. (2016). *Principles and practice of structural equation modeling* (4th ed.). Guilford Press.
- Kvasková, L., Hlado, P., Palíšek, P., Šašinka, V., Hirschi, A., Ježek, S., & Macek, P. (2023). A longitudinal study of relationships between vocational graduates' career adaptability, career decision-making self-efficacy, vocational identity clarity, and life satisfaction. *Journal of Career Assessment*, 31(1), 27–49. <https://doi.org/10.1177/10690727221084106>
- Liñán, F., & Chen, Y. (2009). Development and cross-cultural application of a specific instrument to measure entrepreneurial intentions. *Entrepreneurship Theory and Practice*, 33(3), 593–617. <https://doi.org/10.1111/j.1540-6520.2009.00318.x>
- Lindh, I. (2017). Entrepreneurial development and the different aspects of reflection. *International Journal of Management Education*, 15(1), 26–38. <https://doi.org/10.1016/j.ijme.2016.12.001>
- Loveridge, S., Miller, S. R., Komarek, T. M., & Satimanon, T. (2012). Assessing Regional Attitudes about Entrepreneurship. *Journal of Regional Analysis and Policy*, 42(3), 210–222. <https://doi.org/10.22004/ag.econ.143783>
- Lyu, J., Shepherd, D., & Lee, K. (2023). From intentional to nascent student entrepreneurs: The moderating role of university entrepreneurial offerings. *Journal of Innovation and Knowledge*, 8(1), Article 100305. <https://doi.org/10.1016/j.jik.2023.100305>
- MacKenzie, S. B., & Podsakoff, P. M. (2012). Common method bias in marketing: Causes, mechanisms, and procedural remedies. *Journal of Retailing*, 88(4), 542–555. <https://doi.org/10.1016/j.jretai.2012.08.001>
- Maisyaroh, Arifin, I., Ariyanti, N. S., & Adha, M. A. (2020). The mediating role of entrepreneurship interest on the effect of entrepreneurship education to digital startup preparation in the digital age. In A. P. Putra, N. L. S. Nuraini, P. S. Cholifah, E. Surahman, D. A. Dewantoro, T. A. Rini, R. F. Pradipta, K. M. Raharjo, D. Prestiadi, I. Gunawan, & A. Prastiawan (Eds.), *Proceedings of 1st International Conference On Information Technology And Education* (pp. 211–216). Atlantiss Press. <https://doi.org/10.2991/assehr.k.201214.238>
- Maisyaroh, M., Juharyanto, J., Bafadal, I., Wiyono, B. B., Ariyanti, N. S., Adha, M. A., & Qureshi, M. I. (2021). The principals' efforts in facilitating the freedom to learn by enhancing community participation in Indonesia. *Cakrawala Pendidikan*, 40(1), 196–207. <https://doi.org/10.21831/cp.v40i1.36119>
- Maisyaroh, Mustiningsih, Kusumaningrum, D. E., & Nasih, A. M. (2019). Development of the model of implementation and evaluation of the 21st century community participation in the pesantren-based junior high school. *International Journal of Innovation, Creativity and Change*, 5(4), 599–610. <https://bit.ly/3Tej3ZE>
- Maritz, A., Eager, B., & De Klerk, S. (2021). Entrepreneurship and self-employment for mature-aged people. *Australian Journal of Career Development*, 30(1), 3–14. <https://doi.org/10.1177/1038416220978971>
- Maritz, A., Nguyen, Q., & Ivanov, S. (2022). Student entrepreneurship ecosystems at Australian higher education institutions. *Journal of Small Business and Enterprise Development*, 29(6), 940–957. <https://doi.org/10.1108/JSBED-11-2021-0466>
- Memon, J., Rozan, M. Z. A., Ismail, K., Uddin, M., & Daud, D. K. (2015). Mentoring an entrepreneur: Guide for a mentor. *SAGE Open*, 5(1), 1–10. <https://doi.org/10.1177/2158244015569666>
- Mukesh, H. V., Prabhu, N., Koodamara, N. K., Chakraborty, S., & Kamath, P. (2021). Entrepreneurial potential of students of MBA and engineering schools in the Indian context: Roles of leadership and achievement motivation. *Journal of Applied Research in Higher Education*, 13(3), 782–810. <https://doi.org/10.1108/JARHE-01-2020-0025>

- Ng, Y.-H., Lai, S.-P., Su, Z.-P., Yap, J.-Y., Teoh, H.-Q., & Lee, H. (2017). Factors influencing accounting students' career paths. *Journal of Management Development*, 36(3), 319–329. <https://doi.org/10.1108/JMD-11-2015-0169>
- Nowiński, W., & Haddoud, M. Y. (2019). The role of inspiring role models in enhancing entrepreneurial intention. *Journal of Business Research*, 96, 183–193. <https://doi.org/10.1016/j.jbusres.2018.11.005>
- Nunnally, J. C. (1978). *Psychometric theory* (2nd ed.). McGraw-Hill.
- Otrachshenko, V., Popova, O., Nikolova, M., & Tyurina, E. (2022). COVID-19 and entrepreneurship entry and exit: Opportunity amidst adversity. *Technology in Society*, 71, Article 102093. <https://doi.org/10.1016/j.techsoc.2022.102093>
- Pérez-Pérez, C., González-Torres, T., & Nájera-Sánchez, J.-J. (2021). Boosting entrepreneurial intention of university students: Is a serious business game the key? *The International Journal of Management Education*, 19(3), Article 100506. <https://doi.org/10.1016/j.ijme.2021.100506>
- Podsakoff, P. M., MacKenzie, S. B., & Podsakoff, N. P. (2012). Sources of method bias in social science research and recommendations on how to control it. *Annual Review of Psychology*, 63, 539–569. <https://doi.org/10.1146/annurev-psych-120710-100452>
- Rondli, W. S. (2022). Menumbuhkan nilai kewirausahaan dalam penguatan profil pelajar pancasila melalui pembelajaran project market day [Growing entrepreneurial values in strengthening the profile of Pancasila students through market day project learning]. *Jurnal Prakarsa Paedagogia*, 5(1), 111–117. <https://doi.org/10.24176/jpp.v5i1.8227>
- Roundy, P. T. (2022). Teacher entrepreneurial ecosystems: How local communities support teacher entrepreneurs. *Entrepreneurship Education and Pedagogy*, 5(4), 627–657. <https://doi.org/10.1177/25151274211069032>
- Sabiu, I. T., Abdullah, A., Amin, A., & Tahir, I. M. (2018). An empirical analysis of the need for achievement motivation in predicting entrepreneurial persistence in Bumiputra entrepreneurs in Terengganu, Malaysia. *International Journal of Business and Globalisation*, 20(2), 190–202. <https://doi.org/10.1504/IJBG.2018.089867>
- Schoenfeld, J., Segal, G., & Borgia, D. (2017). Social cognitive career theory and the goal of becoming a certified public accountant. *Accounting Education*, 26(2), 109–126. <https://doi.org/10.1080/09639284.2016.1274909>
- Schumaker, R. E., & Lomax, R. G. (2010). *A beginner's guide to structural equation modeling* (3rd ed.). Routledge/Taylor & Francis Group.
- Setiawan, U. A., Yanto, H., & Prihandono, D. (2021). Model improvement of students' entrepreneurial intentions in SMP Satu Atap Kandangserang. *Journal of Economic Education*, 10(2), 243–251. <https://bit.ly/484aWDb>
- St-Jean, É., & Mathieu, C. (2015). Developing attitudes toward an entrepreneurial career through mentoring: The mediating role of entrepreneurial self-efficacy. *Journal of Career Development*, 42(4), 325–338. <https://doi.org/10.1177/0894845314568190>
- Tabachnick, B. G., & Fidell, L. S. (2007). *Using multivariate statistics*. Pearson Education, Inc.
- Taniguchi, K., & Hirakawa, Y. (2016). Dynamics of community participation, student achievement and school management: The case of primary schools in a rural area of Malawi. *Compare: A Journal of Comparative and International Education*, 46(3), 479–502. <https://doi.org/10.1080/03057925.2015.1038500>
- Tantawy, M., Herbert, K., McNally, J. J., Mengel, T., Piperopoulos, P., & Foord, D. (2021). Bringing creativity back to entrepreneurship education: Creative self-efficacy, creative process engagement, and entrepreneurial intentions. *Journal of Business Venturing Insights*, 15, Article e00239. <https://doi.org/10.1016/j.jbvi.2021.e00239>
- Tiedeman, D. V., & O'Hara, R. P. (1963). *Career development: Choice and adjustment*. Collage Entrance Examination Board.
- Tsordia, C., & Papadimitriou, D. (2015). The role of theory of planned behavior on entrepreneurial intention of Greek business students. *International Journal of Synergy and Research*, 4(1), 23–37. <https://doi.org/10.17951/ijsr.2015.4.1.23>
- Uslu, B., & Arslan, H. (2017). Faculty's academic intellectual leadership: The intermediary relations with universities' organizational components. *International Journal of Leadership in Education*, 21(4), 399–411. <https://doi.org/10.1080/13603124.2016.1278044>
- Uysal, Ş. K., Karadağ, H., Tuncer, B., & Şahin, F. (2022). Locus of control, need for achievement, and entrepreneurial intention: A moderated mediation model. *The International Journal of Management Education*, 20(2), Article 100560. <https://doi.org/10.1016/j.ijme.2021.100560>
- Veleva, V., & Bodkin, G. (2018). Corporate-entrepreneur collaborations to advance a circular economy. *Journal of Cleaner Production*, 188, 20–37. <https://doi.org/10.1016/j.jclepro.2018.03.196>
- Wang, L.-Y., & Huang, J.-H. (2022). The Relationship between internal locus of control and entrepreneurial intentions of

college students: A chain mediation model. *International Journal of Educational Methodology*, 8(1), 139-149. <https://doi.org/10.12973/IJEM.8.1.141>

Wiyono, B. B., & Wu, H.-H. (2022). Investigating the structural effect of achievement motivation and achievement on leadership and entrepreneurial spirit of students in higher education. *Administrative Sciences*, 12(3), Article 99. <https://doi.org/10.3390/admsci12030099>

Wongnaa, C. A., & Seyram, A. Z. K. (2014). Factors influencing polytechnic students' decision to graduate as entrepreneurs. *Journal of Global Entrepreneurship Research*, 4, Article 2. <https://doi.org/10.1186/2251-7316-2-2>