

## Development an Achievement Test on the Subject of “Basic Compounds in the Structure of Living Things”

Funda Yalinkilic, Seyda Gul

Ataturk University, Erzurum, Turkey

**Abstract:** *The aim of this study is to develop a valid and reliable achievement test on the subject of ‘Basic Compounds in the Structure of Living Things’. During the preparation of the draft form of the test, a 32 item-question pool was created by the researchers in the light of the relevant literature. Then, these questions were presented to expert opinion in terms of language, intelligibility and content. This draft test with 32 multiple choice questions, was applied to 252 students studying at three different high schools. Item difficulty and item discrimination indices were calculated for the data obtained. After the item analysis, seven questions were removed from the test. Thus, the average item difficulty of the 25-question achievement test was calculated as 0.44, and the average item discrimination was 0.44. The KR-20 reliability coefficient of the test was calculated as 0.75. This result shows that the test is of medium difficulty and excellent discriminative reliability. In addition, according to the revised Bloom taxonomy, seven of the questions in the test are at the level of remembering, fifteen at the level of understanding, two at the level of application and one at the level of evaluation.*

*Science Insights Education Frontiers 2023; 18(2):2905-2925.*

*Doi: 10.15354/sief.23.or420*

---

*How to Cite: Yalinkilic, F., & Gul, S. (2023). Development an achievement test on the subject of “basic compounds in the structure of living things”. Science Insights Education Frontiers, 18(2):2905-2925.*

---

**Keywords:** *Achievement, Basic Compounds, Living Things, Test Development*

---

---

**About the Authors:** Funda Yalinkilic, Candidate of Master’s, Graduate School of Educational Science, Ataturk University, Erzurum, Turkey, E-mail: [nkala0702@gmail.com](mailto:nkala0702@gmail.com), ORCID: <https://orcid.org/0009-0001-1528-0477>

Şeyda Gul, Assoc. Professor, PhD, Kazım Karabekir Faculty of Education, Ataturk University, Erzurum, Turkey, E-mail: [seydagul@atauni.edu.tr](mailto:seydagul@atauni.edu.tr), ORCID: <https://orcid.org/0000-0003-4005-2158>

**Correspondence to:** Şeyda Gul at Ataturk University of Turkey.

**Funding:** This study was funded by the Scientific Research Project Council of Ataturk University by the Grant SYL-2022-10791. Additionally, it was sent for presenting at the 15th National Science and Mathematics Education Congress, Kars, Turkey.

**Competing Interests:** This article was produced from the master’s thesis of the first author. The authors have no competing interests to declare that are relevant to the content of this article. All authors have participated in the research and in the article preparation. All authors have approved the final article.

**Ethics Approval:** All procedures performed in the study were in accordance with the ethical standards of Atatürk University. Ethic approvals were obtained with the decision (reference no: E-56785782-050.02.04-2200100226) of the Social and Human Sciences Ethics Committee.

**Conflict of Interests:** None

---

© 2023 Insights Publisher. All rights reserved.



Creative Commons NonCommercial CC BY-NC: This article is distributed under the terms of the Creative Commons Attribution-NonCommercial 4.0 License (<http://www.creativecommons.org/licenses/by-nc/4.0/>) which permits non-commercial use, reproduction and distribution of the work without further permission provided the original work is attributed by the Insights Publisher.

## **Introduction**

**S**INCE the first day of its existence, humanity has developed many techniques and approaches to meet its basic needs and to be protected against potential enemies, and these techniques and approaches have been passed on to the next generations through education. Educational processes were also utilized in the transfer of knowledge in fields such as mythology, theology, and philosophy as a result of people's transition to a settled order over time and the socio-cultural interactions that developed afterwards (Duran & Barut, 2019). When all these aspects are considered, it is possible to define education as a system that shows continuity in the process between the birth-death line of a person and at the same time transfers knowledge and experience, which include in learning, using, developing and teaching of concepts from science to philosophy, from economy to art (Gökçe, 1996). The term education, etymologically, consists of two Latin words that mean "leading" and "instructing" (Duran & Barut, 2019). The education system, on the other hand, is a systematic approach that offers important outputs in order to be able to think about the current development level of a country and its future position (Saraçoğlu Yıldırım, 2021). Many definitions of the concept of "education" have been made from the past to the present, and these definitions express education as a process in which desired outcomes are achieved in human behavior (Hançer et al., 2021; Kargın & Gül, 2021).

Today, it is more and more important to acquire knowledge and information. The main purpose of our education system is not to convey the existing information exactly, but to enable people to gain skills in accessing information. This requires problem solving, conceptual learning, scientific method skills and high-level cognitive process skills. Science and biology lessons are important lessons in which these skills are gained (Kaptan, 1998).

The importance of knowledge about natural phenomena in our world is emphasized among the competencies that individuals studying in the secondary education biology curriculum in Turkey should have. At the same time, it has been cited that it is not appropriate to evaluate with a uniform technique and method in measurement and evaluation, as time-dependent changes may occur in the interest, attitude and success of students with individual differences in the education process of the biology course (Ministry of National Education [MoNE], 2018).

In assessment and evaluation exams, tools that measure comprehension and understanding should be preferred rather than measurement tools that push students to memorize. In this regard, Bloom's taxonomy is a classification in which different thinking stages are listed. In this classification, students must have completed the lower stages in order to move on to the upper stages. The knowledge, comprehension and application stages require

low-level thinking skills and students use their thinking skills very little. Analysis, synthesis and evaluation stages express high-level thinking skills and are effective in improving students' ability to access knowledge, checking their existing knowledge, recognizing the problems encountered and producing solutions to them (Gündüz, 2009). The revised final form of the original taxonomy consists of two dimensions: knowledge and cognitive processes (Avcı, 2020). Information types are found in the information dimension of the revised Bloom Taxonomy. These; knowledge based on facts, conceptual knowledge, procedural knowledge and metacognitive knowledge. In the cognitive process dimension, how information is used is examined and consists of the stages of remembering, understanding, applying, analysing, evaluating and creating (Krathwohl, 2002). Taxonomy is an approach that allows the classification of the expected achievements from the students as a result of an instruction. This classification follows a sequence from abstract to concrete, from simple to complex, and each stage constitutes a prerequisite for the other (Bümen, 2006).

With the creation of taxonomies, it has become more possible today to prepare training programs to cover high-level skills in these taxonomies and to measure these skills effectively (Koğar, 2022). In this process, many different techniques and measurement tools are used. One of them is multiple choice tests. Multiple choice tests are the preferred measurement tools in the transition to the next level of educational institutions in our country. In multiple-choice tests, which can have four or five options in accordance with the level of education of the student, there is only one correct answer, but wrong answers are placed on the remaining options. Multiple-choice tests are measurement tools that can be easily applied by teachers to students in their classrooms in limited time, but they are very reliable and highly valid measurement tools. In addition, since it is a curriculum that should be taught in schools, it also saves teachers and students in terms of timing. Its ease of application is also an important factor in its preference. Scoring is very objective and gives reliable results (Kargın & Gül, 2021). Thanks to these advantages, multiple choice tests are frequently used in learning environments. On the other hand, with the revision or renewal of curricula, it is seen that studies on measurement and evaluation tools that measure learning outcomes have increased.

In our country, some updates were made in the high school biology course curriculum in 2018. Following these updates, test development studies on biology subjects are encountered. A list of studies is shown in **Table 1**:

When **Table 1** is examined, it is seen that test development studies for the updated curriculum of the biology course are quite limited. However, when the literature is examined, it is noteworthy that test development studies on biology subjects are mostly carried out at lower grade levels within the scope of science courses. For example, one of these studies was con-

**Table 1. Test Development Studies on Subjects of Biology Course Curriculum in 2018.**

| Researchers        | Subject            | Sample Size | Number of Items | Average Item Difficulty | Average Item Discrimination | KR20 Reliability Coefficient |
|--------------------|--------------------|-------------|-----------------|-------------------------|-----------------------------|------------------------------|
| Çakır & Arı (2022) | The Cell           | 123         | 22              | 0.55                    | 0.44                        | 0.89                         |
| Kaya & Gül (2020)  | Digestive System   | 201         | 25              | 0.56                    | 0.34                        | 0.91                         |
| Görmüş (2021)      | Circulatory System | 200         | 35              | 0.54                    | 0.50                        | 0.88                         |

ducted by Bolat and Karamustafaoğlu (2019) on unit "Systems in our Body". As a result of the analysis of the data obtained from 427 sixth grade students, a 35-item test was developed. The mean item difficulty of the test was 0.552, and the mean item discrimination was 0.486. The reliability coefficient was determined as 0.885.

Karlı et al. (2019) performed a test development study on "Cells and Divisions". As a result of the analyses made with the data collected from 409 7th grade students, a 36-question multiple-choice achievement test was developed. According to the findings, the average difficulty of the test was calculated as 0.478 and the average discrimination as 0.452. In addition, KR-20 reliability coefficient of the achievement test was found to be 0.865.

In another study, Kargın and Gül (2021) developed an achievement test on "Supervisory and Regulatory Systems" and "Sensory Organs". In the study conducted with 212 sixth grade students, a multiple choice achievement test consisting of 40 questions was developed. In the analyses performed, the mean difficulty of the test was calculated as 0.61, and the mean discrimination was calculated as 0.47. The reliability analysis of the test was made with data collected from 178 students. According to the findings obtained, the KR-20 reliability coefficient was calculated as 0.86.

Şentürk and Selvi (2021) performed a test development on subject "Human and Environment". As a result of the analysis of the data obtained from 273 students, a 27-item test was developed. The mean item difficulty of the test was 0.62, and the mean item discrimination was 0.47. The reliability coefficient was determined as 0.82.

When the above studies are evaluated, it can be said that there is a need for test development studies on different biology subjects at high school level. On the other hand, according to the new curriculum, a student who starts taking biology lessons at the secondary education level in Turkey receives training on "common features of living things" and "basic compounds in the structure of living things" under the unit title of "Life Science Biology" in the first year of education. In this unit, inorganic compounds and

organic compounds are included in the subject of basic compounds found in the structure of living things. In these subjects, students are informed in a wide spectrum such as the formation of macromolecules from monomers, the functions of compounds in nature and in the human body (MoNE, 2018).

The subject of "Basic Compounds in the Structure of Living Things" in the 9th grade biology curriculum in our country is also associated with the unit "General Principles of Heredity" in the 10th grade biology course, "Human Physiology" in the 11th grade, "From Gene to Protein", "Energy Conversions in Living Things", "Plant Biology" and "Living Things and Environment" in the 12th grade. On the other hand, in secondary education chemistry course; it is directly or indirectly related to different fields such as "Interactions Between Chemical Species", "Nature and Chemistry" in 9th grade, "Chemistry is Everywhere" in 10th grade, "Introduction to Carbon Chemistry" and "Organic Compounds" in 12th grade. This situation makes the researches carried out on the subject of basic compounds in the structure of living things remarkable in terms of different sub-branches of biology and chemistry. On the other hand, the fact that the compounds in the subject are micro-scale and that it requires using imagination while learning about molecules and molecule interactions that cannot be seen with the naked eye in the teaching process makes it important to focus on the teaching and assessment-evaluation process of such a difficult subject. Because, at any stage of an education process, a measurement process is carried out to determine the level and quality of learning, and the determination of the level of proficiency of the students on the subject is provided by evaluation on the results achieved (Ada & Baysal, 2018). In addition, knowing the achievement levels of the students in this subject will be effective in learning the next subjects. Multiple-choice tests are frequently used to determine the achievement of students. However, an achievement test developed for the subject of Basic Compounds in the Structure of Living Beings, which is included in the biology curriculum updated in 2018 in our country, has not been found in the literature. It is thought that developing an achievement test that evaluates the achievements of students on this subject will contribute to the literature on measurement and evaluation.

## ***Purpose of the Research***

The purpose of this research is to develop a multiple-choice achievement test with tested validity and reliability for the subject of "Basic Compounds in the Structure of Living Beings" in the ninth grade biology curriculum. For this purpose, answers to the following research questions were sought:

1. Is the test developed to determine the success levels of ninth grade students on the basic compounds in the structure of living things valid?

2. Is the test developed to determine the success levels of ninth grade students on the basic compounds in the structure of living things reliable?

## **Method**

In this study, it was carried out with the survey method, which is considered in quantitative research designs. Survey studies are used to obtain information about people's attitudes, beliefs, values, demographic characteristics, behaviors, ideas, habits, desires and other types of information (McMillan & Schumacher, 2010). In this study, the survey method was preferred in order to develop a test that determines the achievement levels of the students.

The sample group in the item analysis phase of the research consists of 252 (144 females, 108 male) students from three schools randomly selected from among secondary schools in a province in the west of Turkey. Of the students participating in the applications, 122 (71 females, 51 male) were selected from the first school, 79 (48 females, 31 male) from the second school and 51 (25 females, 26 male) from the third school. According to this, 57.1% of the students are female and 42.8% male in total. Although there is no equivalence between the schools in terms of the number of students, it is assumed that this distribution will not adversely affect the research findings, since all of the schools are public schools and are located in socio-culturally close regions.

### ***The Development Process of the Achievement Test***

While developing the achievement test in the research, the test development steps (determining the purpose of the test, determining the content of the test, making the validity and reliability analyzes of the questions in the test, etc.) recommended by Haladyna (1997) and Kızılkapan and Bekaş (2018) were considered. For this, first of all, the purpose of the test was determined in the first step of the test development process. Accordingly, the purpose of the test is to measure achievement in the subject of 'Basic Compounds Found in the Structure of Living Things' in the Life Science Biology unit at the ninth grade level.

After the purpose of the test was determined, the researchers first made a literature review and examined the relevant resources (textbook, test books, internet resources, etc.). As a result of the examinations, a total of 32 multiple-choice questions containing the learning outcomes and concepts of the subject of Basic Compounds in the Structure of Living Beings in the most recently updated ninth grade Biology Curriculum (Ministry of National Education [MoNE], 2018) were prepared.

As stated by Tunç and Kılınç-Alpat (2015), in the process of developing an achievement test, content validity is mostly checked and it is abso-

**Table 2. The Specification Table of the Questions in the Draft Achievement Test.**

| Learning Outcomes  | Remembering                     | Understanding   | Application     | Analyzing | Evaluating | Creating |
|--|---------------------------------|---|-----------------|-----------|------------|----------|
| Explain the organic and inorganic compounds in the structure of living things.   | Q2, Q3, Q10, Q13, Q22, Q23, Q24 | Q1, Q5, Q6, Q7, Q11, Q12, Q14, Q16, Q19, Q20, Q21, Q26, Q30 | Q4, Q8, Q9, Q15 | Q18, Q25  | Q17, Q29   | -        |
| Establishes the relationship between lipids, carbohydrates, proteins, vitamins, water and minerals with healthy nutrition. | -                               | Q28, Q31, Q32   | -               | -         | Q27        | -        |

**Table 3. Item Analysis Results of the Achievement Test.**

| Question | C <sub>Lower group</sub> | C <sub>Upper group</sub> | pj          | rjx         | Question | C <sub>Lower group</sub> | C <sub>Upper group</sub> | pj          | rjx          |
|----------|--------------------------|--------------------------|-------------|-------------|----------|--------------------------|--------------------------|-------------|--------------|
| Q1       | 18                       | 62                       | 0.59        | 0.65        | Q17      | 12                       | 9                        | <b>0.15</b> | <b>-0.04</b> |
| Q2       | 29                       | 62                       | 0.67        | 0.49        | Q18      | 10                       | 6                        | <b>0.12</b> | <b>-0.06</b> |
| Q3       | 19                       | 61                       | 0.59        | 0.62        | Q19      | 13                       | 47                       | 0.44        | 0.50         |
| Q4       | 23                       | 42                       | 0.48        | 0.28        | Q20      | 9                        | 44                       | 0.39        | 0.51         |
| Q5       | 17                       | 46                       | 0.46        | 0.43        | Q21      | 4                        | 17                       | <b>0.15</b> | <b>0.19</b>  |
| Q6       | 16                       | 59                       | 0.55        | 0.63        | Q22      | 8                        | 31                       | <b>0.29</b> | 0.34         |
| Q7       | 35                       | 61                       | 0.71        | 0.38        | Q23      | 14                       | 48                       | 0.46        | 0.50         |
| Q8       | 15                       | 18                       | <b>0.24</b> | <b>0.04</b> | Q24      | 8                        | 41                       | 0.36        | 0.49         |
| Q9       | 14                       | 41                       | 0.40        | 0.40        | Q25      | 10                       | 18                       | <b>0.21</b> | <b>0.12</b>  |
| Q10      | 17                       | 29                       | 0.34        | <b>0.18</b> | Q26      | 13                       | 50                       | 0.46        | 0.54         |
| Q11      | 9                        | 52                       | 0.45        | 0.63        | Q27      | 14                       | 12                       | <b>0.19</b> | <b>-0.03</b> |
| Q12      | 14                       | 40                       | 0.40        | 0.38        | Q28      | 16                       | 27                       | 0.32        | <b>0.17</b>  |
| Q13      | 8                        | 44                       | 0.38        | 0.53        | Q29      | 9                        | 35                       | 0.32        | 0.38         |
| Q14      | 7                        | 41                       | 0.35        | 0.50        | Q30      | 14                       | 34                       | 0.35        | <b>0.29</b>  |
| Q15      | 14                       | 21                       | <b>0.26</b> | <b>0.10</b> | Q31      | 17                       | 50                       | 0.49        | 0.49         |
| Q16      | 19                       | 38                       | 0.42        | 0.28        | Q32      | 17                       | 41                       | 0.43        | 0.35         |
| Overall  |                          |                          |             |             |          |                          |                          | 0.44        | 0.44         |

*C<sub>Lower group</sub>*: Number of students who answered correctly in the lower group

*C<sub>Upper group</sub>*: Number of students who answered correctly in the upper group

lutely taken into account to what extent the questions in the test represent the relevant content. When the literature is examined, it is a frequently preferred method to consult an expert in determining the content validity of a test (Çalık & Ayas, 2003; Treagust, 1988). Thus, in line with expert opinions, information can be obtained about whether the test can measure the feature it



wants to measure, and it can be re-focused on incomplete or contradictory statements (Çalık & Ayas, 2003). From this point of view, the achievement test prepared by the researchers of this study was examined by two faculty member and a biology teacher in terms of language, content, appearance, content, etc. Minor revisions were made in a few questions in the test in line with expert opinions. At the same time, the questions were distributed according to the steps in the revised Bloom's taxonomy (**Table 2**).

According to **Table 3**, seven of the 32 questions are in the remembering, sixteen in the understanding, four in the application, two in the analyzing and three in the evaluating stage.

After expert opinion, the test was applied to 252 students for validity and reliability analysis. During the face-to-face applications, students were prevented from cheating and necessary warnings were made. In addition, it was promised to the students that the application is for research purposes, that their answers will be kept confidential and that the scores will not be used in evaluation in any way. Students were given one class hour (40 minutes) to administer the test. The results of the validity and reliability analysis on the collected data are presented in the findings section.

## Findings

After the test was administered to 252 students after expert opinions, item difficulty and item discrimination indices were calculated. For this, the students were divided into 27% lower group and upper group according to their test scores. Accordingly, the answers of 68 students from each group were analyzed (**Table 3**).

Item difficulty index ( $p_j$ ) is the percentage of participants in the upper and lower groups who answered the item correctly. The discrimination index ( $r_{jx}$ ) is the ability of a test item to distinguish between high- and low-level participants. Assimi et al. (2022) stated that items with  $p_j > 70\%$  were classified as very easy, and items with  $p_j < 30\%$  were classified as difficult. In addition, items with  $r_{jx} \leq 0.20$  are classified as poor, between 0.21 and 0.34 acceptable or good, and  $\geq 0.35$  excellent.

According to **Table 3**, the item difficulty index value was determined as difficult for eight questions (S8, S15, S17, S18, S21, S22, S25, and S27). All other questions are of medium difficulty. In terms of item discrimination values, ten questions (S8, S10, S15, S17, S18, S21, S25, S27, S28, and S39) were discriminating at a weak level and the others at a good or excellent level. Accordingly, seven questions (S8, S15, S17, S18, S21, S25, and S27) whose both item difficulty index and discrimination index were below the desired limits were excluded from the test. On the other hand, S22 was left out of the test because the item difficulty index was borderline and the item discrimination level was good. S10, S28, and S30 were left in the test, al-

**Question 23.**  
Regarding the numbered parts of a tRNA given below;

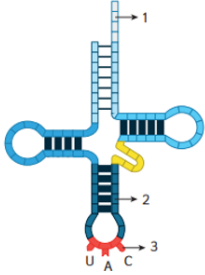

I. Part 1 is the amino acid binding end.  
II. Part 2 is weak hydrogen bonds between ribonucleotides.  
III. Part 3 is the anticodon, which is a triple nucleotide that determines the type of tRNA.

Which of the statements are true?

A) Only I                      B) Only II                      C) Yalnız III  
D) II ve III                    E) I, II ve III

**Figure 1. An Example Question of the Achievement Test.**

though the item discrimination levels were a little low, because the difficulty indexes were within the desired limits and there were few questions in the learning outcome related to that subject in the test. As a result, the average item difficulty of the achievement test, which includes a total of 25 questions, was calculated as 0.44, and the average item discrimination was calculated as 0.44. The KR-20 reliability coefficient of the test was calculated as 0.75. This result shows that the test is of medium difficulty and excellent discriminative reliability.

An example question of the achievement test is shown in **Figure 1**.

In addition, according to the revised Bloom taxonomy, seven of the questions in the test are at the level of remembering, fifteen at the level of understanding, two at the level of application and one at the level of evaluating. As such, the questions in the test were renumbered and the specification table showing the learning outcomes and the level in the revised Bloom taxonomy is presented in **Table 4**. The final form of the test is given in **Appendix I**.

## Discussion

Determining how much of the information transferred to the students in the learning environment can be determined by measuring their academic achievement. However, it is very important to develop tests with high valid-

**Table 4. The Specification Table of the Questions in the Final Form of the Achievement Test.**

| Learning Outcomes  | Description of learning outcomes   | Questions     | Bloom taxonomy |
|--|--|---------------|----------------|
| Explain the organic and inorganic compounds that make up the structure of living things.   | The importance of water, minerals, acids, bases and salts for living things is explained.  | Q2            | Remembering    |
|  |  | Q6            | Understanding  |
|  |  | Q7            | Understanding  |
|  |  | Q11           | Understanding  |
|  |  | Q12           | Understanding  |
|  |  | Q18           | Evaluating     |
|  | The importance of calcium, potassium, iron, iodine, fluorine, magnesium, sodium, phosphorus, chlorine, sulfur and zinc minerals for living things is emphasized. | Q25           | Understanding  |
|  |  | Q11           | Understanding  |
|  |  | Q12           | Understanding  |
|  | The structure and function of carbohydrates, lipids, proteins, nucleic acids, enzymes and their importance for living things are explained.                      | Q18           | Evaluating     |
|  |  | Q9            | Applying       |
|  |  | Q10           | Remembering    |
|  |  | Q13           | Remembering    |
|  |  | Q14           | Understanding  |
| It is emphasized that DNA is found in all living species and contains the same nucleotides.  | Q16  | Understanding |                |
|  | Q23  | Remembering   |                |
|  | Q10  | Remembering   |                |
| Without including the chemical formulas of ATP and hormones, its importance for living things is questioned.   | Q17  | Understanding |                |
|  | Q22  | Remembering   |                |
|  | Q24  | Remembering   |                |
| General properties of vitamins are given. The functions of vitamins A, D, E, K, B and C and their importance for living things are explained. The types of B group vitamins are not mentioned. | Q3   | Remembering   |                |
|  | Q5   | Understanding |                |
|  | Q19  | Understanding |                |
|  | Q20  | Understanding |                |
| Students are provided to carry out experiments in which they can detect the presence of carbohydrates, lipids and proteins in foods.   | Q9   | Applying      |                |
|  | Experiments on factors affecting enzyme activity are provided.   | Q1            | Understanding  |
| Establishes the relationship between lipids, carbohydrates, proteins, vitamins, water and minerals with healthy nutrition.   | Q4   | Applying      |                |
|  | Insulin resistance, diabetes, and obesity are addressed in the context of healthy eating.  | Q8            | Understanding  |
|  | Q21  | Understanding |                |
|  | Students are provided to prepare a one-week healthy nutrition program for their age group.   | Q15           | Understanding  |

ity and reliability that are compatible with learning outcomes in order to determine the level of achievement and evaluate the effectiveness of the program. In this study, it is aimed to develop a valid and reliable multiple-choice test on the ninth grade 'Basic Compounds Found in the Structure of Living Things'.

Considering that achievement tests are used as a tool in research to measure students' achievement, it is important that these tests are valid tests in terms of content and construct (Üçüncü & Sakız, 2020). The stages followed in the achievement tests developed in the literature are similar to this

study (Açıkgöz & Karıslı, 2015; Bolat & Karamustafaođlu, 2019; Haladyna, 1997; Kargın & Gül, 2021; Kızıkapın & Bekaş, 2018). For example; Açıkgöz and Karıslı (2015) explained the processes followed in the achievement test developed on business and energy in eight steps. At these stages, the purpose and content of the test were determined by considering the findings of the studies on the subject. In the following processes, a specification table was prepared and the features that could be measured by the test were determined. Thus, a 32-question draft test was prepared, considering the learning outcomes related to the subject. The draft test was presented to the expert opinion and then applied to the students. Thus, the studies for content validity were examined in detail, the application of the draft form and the item analyzes made as a result of this application were included. A similar study was conducted by Can Şen and Eryılmaz (2011), on simple electrical circuits. While developing the achievement test, these researchers followed a six-stage path: determining the learning outcomes, preparing the specification table, creating the test items, preparing the draft form by taking expert opinion, performing the item analysis by applying the draft form, and creating the final form. However, due to the fact that the questions were examined by a small number of experts, it is considered as a limitation of this study that it is not determined whether the agreement between the expert opinions taken to ensure the content validity proposed by Akbulut and Çepni (2013) and Üçüncü and Sakız (2020) is valid.

In the process of developing the achievement test in the study, first of all, a total of 32 questions were prepared by examining the literature by the researchers. While preparing the questions, the learning outcomes specified in the ninth grade Biology Curriculum (MoNE, 2018) were considered. Atılgan et al. (2011) recommends writing three items for each learning outcome in the specification table while preparing the draft form for the test items. From this point of view, at least three questions were prepared for each learning outcome in this study. Thus, the content validity of the test was tried to be increased. In addition, the opinions of experts consisting of a biology teacher and two faculty members were taken to test the content validity of the test. After the content validity study, the draft test for item analysis was applied to 252 students. After the item analysis, the average difficulty of the test, which was reduced to 25 questions, was calculated as 0.44, and the average item discrimination was calculated as 0.44. According to Assimi et al. (2022), these results show that the test has medium difficulty and excellent discrimination.

In the development of achievement tests, it is necessary to determine the learning outcomes to be examined by the test and the question types appropriate for the cognitive levels expressed by these learning outcomes (Üçüncü & Sakız, 2020). As a matter of fact, Özkan & Yadigarođlu (2020) also argue that the renewed Bloom Taxonomy should be included in addition

to validity and reliability studies while preparing the test. Thus, it is possible to classify the test items in a more understandable and detailed manner. In addition, Bloom's taxonomy cognitive domain classification is frequently used in the field of education because it allows the aims of the items to be clearly and observable (Ayvaci & Türkdoğan, 2009). When the findings of this study are examined, according to the revised Bloom's taxonomy, seven of the questions in the test are at the level of remembering, fifteen at the level of understanding, two at the level of application and one at the level of evaluating. When the seven questions that were removed as a result of the item analysis were examined; it is at understanding level one question (Q21), applying two questions (Q8, Q15), analyzing two questions (Q18, Q25) and evaluating two questions (Q17, S27). Therefore, the fact that the questions measure high-level knowledge according to Bloom's taxonomy caused the students not to be able to answer the questions correctly. As a matter of fact, item difficulty index values show that these questions are difficult. In addition, the findings of the item analysis revealed that the discrimination of the questions was low. Therefore, it was decided to exclude these questions from the test.

According to the findings of the study, the KR-20 reliability coefficient is 0.75. Accordingly, it can be said that the test is reliable. The findings of many of the test development studies in the literature (Kargin & Gül, 2021; Nacaroglu et al. 2020, Özcan et al. 2019; Özkan, & Yadigaroglu, 2020; Soylu et al., 2020; Timur et al., 2019) are similar to the findings of this study and reveal that the developed tests are reliable.

## **Conclusion and Suggestions**

As a result of the validity and reliability analyzes in the study, it is seen that the 25-question achievement test measures all the learning outcomes in the curriculum. Accordingly, while there are three questions in the second learning outcome of the subject "Basic Compounds in the Structure of Living Beings", all of the other questions are included in the first learning outcome. However, considering the subject content in the curriculum, it is normal that the questions are not evenly distributed over the learning outcomes. Because, according to the curriculum, most of the subjects and concepts are included in the first learning outcome. Therefore, it is thought that the achievement test is compatible with the learning outcomes in the biology curriculum and completely covers the content in the curriculum. From this point of view, it is thought that the achievement test developed in this study will provide detailed information about the learning levels of the students. In addition, since the reliability and validity of the test have been measured, it can be used by biology education researchers in scientific studies. At this point, it is thought that the test will help to compare the achievement of the student groups

formed by the researchers in experimental studies. On the other hand, no achievement test was found for the ninth grade biology lesson 'Basic Compounds Found in the Structure of Living Beings' in accordance with the objectives of the biology curriculum updated in 2018. It is thought that this study can serve as an example for different tests to be prepared at the ninth grade level in the curriculum. Of course, in the light of these findings reached within the scope of the study, considering some of the limitations encountered in the research process, it is considered appropriate to make some suggestions to guide future research. Accordingly, recommendations are presented below:

- During the development process of the achievement test in the study, the commonly preferred stages in the literature were followed. However, due to the participation of very few experts, the compatibility of these opinions could not be examined by taking the expert opinions for the content validity of the test. Therefore, in a similar study to be carried out in the future, new tests can be developed by considering the criteria (Lawshe technique) that Webb (1997) put forward to ensure the harmony between learning outcomes and exams.
- Since multiple-choice tests are insufficient to measure knowledge at the higher levels of the cognitive domain, no questions at the creating level could be prepared in the test developed in this study. For this reason, when the test is used to measure students' achievement levels, an appropriate open-ended question can be added to the creating level.
- In the study, as a result of item analysis, the questions at the analyzing level were excluded from the test. In future research, new achievement tests with questions at analyzing level can be developed. In addition, two or three-stage multiple-choice tests can be developed.
- As stated by Ozcan et al. (2019), while selecting the sample in the process of developing achievement tests, it is thought that choosing the sample number from large schools with different achievement levels will increase the validity of the study. For this reason, it can be recommended to develop and apply tests that can appeal to wider audiences by selecting schools with different achievement levels in similar studies to be carried out in the future.

### ***Acknowledgement***

*All authors would like to thank all students for their contribution to the process of administering the test.*

## References

- Açıkgöz, M., & Karlı, F. (2015). Validity and reliability analysis of achievement test developed on work and energy by using alternative measurement-evaluation techniques. *Amasya Education Journal*, 4(1): 1-25.
- Ada, S. & Baysal, Z.N. (2018). Sınıf Yönetimi [Classroom Management]. Nobel publishing. ISBN: 978-605-320-860-0. pp. 6-7.
- Akbulut, H. İ. & Çepni, S. (2013). How to develop an achievement test for a unit? Elementary 7th grade force and motion unit. *Amasya Education Journal*, 2(1):18-44.
- Assimi, E., Idrissi, R.J., Zerhane, R., & Boubih, S. (2022). The use of a three-tier diagnostic test to investigate conceptions related to cell biology concepts among pre-service teachers of life and earth sciences. *Journal of Biological Education*, 2022:2134175. DOI: <https://doi.org/10.1080/00219266.2022.2134175>
- Atılğan, H., Kan, A., & Doğan, N. (2013). Eğitimde Ölçme ve Değerlendirme [Measurement and Evaluation in Education]. Anı publishing. ISBN: 978-9944-474-80-1. pp. 316.
- Avcı, F. (2020). An achievement test matter and heat based on renewed Bloom taxonomy: Validity reliability study. *Iğdır University Journal of Social Sciences*, 21: 263-292.
- Ayvacı, H. Ş., & Türkdoğan, A. (2010). Examining the written questions of science and technology course according to the re-structured Bloom taxonomy. *Journal of Turkish Science Education*, 7(1):13-25. DOI: <https://doi.org/10.17121/ressjournal.302>
- Bolat, A., & Karamustafaoğlu, S. (2019). Development achievement of test on the unit "Systems in Our Body": Validity and reliability. *Gazi Journal of Education Sciences*, 5(2): 131-159. DOI: <https://dx.doi.org/10.30855/gjes.2019.05.02.008>
- Bümen, N. T. (2006). A Revision of the Bloom's taxonomy: A turning point in curriculum development. *Education and Science*, 31(142): 3-14.
- Çakır, H., & Arı, G. A. (2022). Development and validation of an achievement test in biology. *Journal of Social Sciences and Education*, 5(1):64-75.
- Çalık, M., & Ayas, A. (2003). Preparing and applying concept achievement test in solutions. *Pamukkale University Journal of Education*, 2(14):1-17.
- Can Şen, H. & Eryılmaz, A. (2011). An achievement test development study: Reliability and validity investigation of simple electric circuits achievement test. *Van Yüzüncü Yıl University Journal of the Faculty of Education*, 8(1):1-39.
- Duran, V., & Barut, Y. (2019). Erken Çocuklukta Fen Eğitimi [Early Childhood Science Education]. Nobel publishing. ISBN: 978-605-7846-52-5. pp. 10.
- Gökçe, B. (1996). Türkiye'nin Toplumsal Yapısı ve Toplumsal Kurumlar [Turkey's Social Structure and Social Institutions]. Savaş publishing. ISBN: 9786057867285. pp:373.
- Görmüş, G. (2021). Dolaşım sistemi konusunun öğretiminde bağlam temelli öğrenme yaklaşımindaki react stratejisine göre hazırlanan etkinliklerin öğrencilerin öğrenme ürünleri üzerine etkisi. Master thesis, Ondokuz Mayıs University, Samsun.
- Gündüz, Y. (2009). Analysis of primary school 6, 7 and 8. grades science and technology questions according to measurement scales and Bloom's taxonomy of the cognitive domain. *Van Yüzüncü Yıl University Journal of the Faculty of Education*, 6(2): 150-165.
- Haladyna, T. M. (1997). Writing Test Items to Evaluate Higher Order Thinking. Pearson publishing. ISBN-10:0205178758. pp: 272.
- Hançer, M., Aydoğan, N., & Çankaya, Ö. (2021). Development of a success test for measuring basic laboratory science knowledge of science teacher candidates: Validity and reliability analysis. *International Journal of Education Science and Technology*, 7(1):57-76. DOI: <https://doi.org/10.47714/uebt.837550>
- Kaptan, F. (1999). Fen Bilgisi Öğretimi [Science Teaching]. National Education Publishing. ISBN: 975.11.1729.1. pp: 22.
- Kargın, P. D., & Gül, Ş. (2021). Development of an achievement test for sixth grade body systems and health unit. *Ihlara Journal of Educational Research*, 6(1):1-26. DOI: <https://doi.org/10.47479/ihead.729412>
- Karlı, G., Karamustafaoğlu, S., & Kurt, M. (2019). Achievement test of the 7th class "Cells and Divisions" unit for the re-

- newed science curriculum: Validity and reliability. *Journal of Science Teaching*, 7(1):68-98.
- Kaya, S., & Gül, Ş. (2020). The development of the achievement test for 11th graders about the "digestive system". *International Journal of Social and Educational Sciences*, 7(13):72-97. DOI: <https://doi.org/10.20860/ijoses.701311>
- Kızılkapan, O., & Bektaş, O. (2018). Development of an achievement test in science education: Example of cell division and inheritance. *International Journal of Educational Sciences*, 2(1):1-18.
- Koçar, E. Y. (2022). Suggestions for designing multiple choice items for high-order thinking skills with examples from the healthcare field. *Journal of Nursology*, 25(2):117-125. DOI: <https://doi.org/10.5152/JANHS.2022.875827>
- Krathwohl, D. R. (2002). A Revision of Bloom's taxonomy: An overview. *Theory into Practice*, 41(4): 212-264.
- McMillan, J.H. & Schumacher, S. (2010). Research in Education: Evidence-Based Inquiry. Pearson publishing. ISBN-13: 978-0-13-136418-8. pp: 235.
- Ministry of National Education [MoNE] (2018). Ortaöğretim kurumları biyoloji dersi öğretim programı, Talim terbiye kurulu başkanlığı [Secondary education institutions biology course curriculum, Education and training board presidency]. 24 June, Available at: <http://mufredat.meb.gov.tr/Dosyalar/20182215535566-Biyoloji%20d%C3%B6p.pdf>
- Nacaroğlu, O., Bektaş, O., & Kızılkapan, O. (2020). Developing an achievement test for matter cycles and environmental problems: A validity and reliability study. *Kastamonu Education Journal*, 28(1):36-51. DOI: <https://doi.org/10.24106/kefdergi.3374>
- Özcan, H., Koca, E., & Söğüt, M. (2019). Development of an instrument for measuring secondary school students' understanding of pressure. *Journal of Research in Education and Society*, 6(1):130-144.
- Özkan, S. & Yadigaroglu, M. (2020). Development of achievement test: A validity and reliability research for acid-base achievement test. *Turkish Studies-Education*, 15(2):1141-1163. DOI: <https://dx.doi.org/10.29228/TurkishStudies.41734>
- Saraçoğlu Yıldırım, Ö. (2021). 8. sınıf öğrencileri için okuduğunu anlama becerisine ilişkin başarı testi geliştirme ve testin LGS'yi yordama düzeyi. Master thesis, Selcuk University, Konya.
- Şentürk, Ö. Ç., & Selvi, M. (2021). Science course "Human And Environment" unit academic achievement test development: Reliability and validity study. *Journal of Gazi Education*, 41(2):601-630.
- Soylu, Ü. İ., Karamustafaoğlu, S., & Karamustafaoğlu, O. (2020). 6th grade "matter and heat" unit achievement test development: validity and reliability. *Ihlara Journal of Educational Research*, 5(2): 271-293. DOI: <https://doi.org/10.47479/ihed.800620>
- Timur, S., Doğan, F., İmer-Çetin, N., Timur, B., & Işık, R. (2019). Developing achievement test on cell subject for 6th grade: A validity and reliability study. *Cukurova University Faculty of Education Journal*, 48(2):1202-1219. DOI: <https://dergipark.org.tr/tr/pub/cuefid>
- Treagust, D.F. (1988). Development and use of diagnostic tests to evaluate students' misconceptions in science. *International Journal of Science Education*, 10(2):159-169.
- Tunç, T., & Kılınç-Alpat, S. (2015). Developing a valid and reliable chemistry achievement test in electrochemistry. *Journal of Higher Education and Science*, 5(3):347-360. DOI: <https://doi.org/10.5961/jhes.2015.136>
- Üçüncü, G., & Sakız, G. (2020). The phases of achievement test development: The case of fourth-grade introduction to matter unit. *Kastamonu Education Journal*, 28(1):82-94. DOI: <https://doi.org/10.24106/kefdergi.3440>
- Webb, N. L. (1997). Determining alignment of expectations and assessments in mathematics and science education. NISE Brief, 1(2): 1-8. Madison, WI: University of Wisconsin-Madison, National Institute for Science Education.

Received: 12 June 2023

Revised: 23 June 2023

Accepted: 6 July 2023



## APPENDIX I. Final Form of Achievement Test.

Adı-Soyadı: \_\_\_\_\_

Sınıfı: \_\_\_\_\_

### 'CANLILARIN YAPISINDA BULUNAN TEMEL BİLEŞİKLER' BAŞARI TESTİ

**S.1) Aşağıdaki deneyde aynı miktarda et; bütün, kuşbaşı ve kıyma haline getirilip kaplara konulduktan sonra üzerlerine hidroliz enzimleri ilave edilmiştir.**

Hidroliz enzimleri



Bütün et  
I



Kuşbaşı et  
II



Kıyma  
III

**Deneyin sonunda kaplardaki ürün oluşum hızı ve nedeni hangisinde doğru olarak verilmiştir?**

| Ürün Oluşum Hızı | Nedeni                   |
|------------------|--------------------------|
| A) III > II > I  | Substrat yüzeyi farkı    |
| B) III > II > I  | Substrat yoğunluğu farkı |
| C) I > II > III  | Substrat yüzeyi farkı    |
| D) I > II > III  | Substrat yoğunluğu farkı |
| E) III > I > II  | Substrat yüzeyi farkı    |

**S.2) Asitlerle ilgili olarak aşağıda verilenlerden hangisi yanlıştır?**

A) Tatları ekşidir.  
B) pH değerleri 7'nin altındadır.  
C) Sulu çözeltilerine OH<sup>-</sup> iyonu verir.  
D) Mavi turnusol kâğıdını kırmızıya çevirir.  
E) Bazlarla birleştiğinde tuzları oluşturur.

**S.3)**

- İnce bağırsak ve böbreklerden Ca<sup>2+</sup> emilimini kolaylaştırır.
- Kemiklere Ca<sup>2+</sup> geçişini sağlayarak kemiklerin güçlenmesini sağlar.
- Eksikliğinde çocuklarda raşitizm, yetişkinlerde osteomalazi hastalığı görülür.

**Bazı özellikleri yukarıda verilen vitamin çeşidi aşağıdakilerden hangisidir?**

A) A vitamini      B) B vitamini      C) C vitamini  
D) D vitamini      E) E vitamini

**S.4) Aşağıda gösterildiği gibi sınırlı miktarda maltaz enzimi bulunan bir deney tüpüne, sürekli maltoz ilave edilmektedir.**

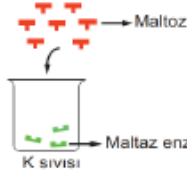

Maltoz  
Maltaz enzimi  
K sıvısı

**Buna göre reaksiyon hızı-zaman grafiği aşağıdakilerden hangisinde doğru olarak verilmiştir?**

**A)**



Reaksiyon hızı  
Zaman

**B)**

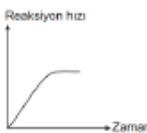

Reaksiyon hızı  
Zaman

**C)**

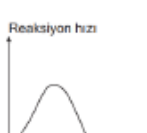

Reaksiyon hızı  
Zaman

**D)**



Reaksiyon hızı  
Zaman

**E)**



Reaksiyon hızı  
Zaman

S.5)

- I. B vitamini
- II. C vitamini
- III. K vitamini
- IV. A vitamini

Yukarıda verilen vitamin çeşitlerinin eksik alınması durumunda belirecek,

- a. kansızlık
- b. skorbut
- c. kanın pıhtılaşmaması
- d. gece körlüğü

hastalıklarının doğru eşleştirilmesi aşağıdaki seçeneklerin hangisinde gösterilmiştir?

| I    | II | III | IV |
|------|----|-----|----|
| A) a | b  | c   | d  |
| B) a | c  | b   | d  |
| C) b | d  | a   | c  |
| D) b | c  | d   | a  |
| E) c | a  | d   | b  |

S.6) Depresyon, diş çürüğü, egzama, saç dökülmesi gibi rahatsızlıkların nedeni vücudumuzdaki asit baz dengesinin bozulmasıdır.

Bu durum, asit ve bazların aşağıda verilen hangi özelliğinden kaynaklanır?

- A) Sindirim için ortam oluşturmaları
- B) Enerji vermeleri
- C) Homeostasiyi etkilemeleri
- D) İnorganik olmaları
- E) Hücre zarından geçebilmeleri

S.7) Böceklerin su üzerinde yürüyebilmeleri suyun;

- I. öz ısısının yüksek olması,
- II. sıvı hâlden gaz hâline geçebilmesi,
- III. besin maddeleri için iyi bir çözücü olması,
- IV. su molekülleri arasında oluşan hidrojen bağlarının neden olduğu yüzey gerilimi özelliklerinden hangileri ile açıklanabilir?

- A) II ve III
- B) Yalnız IV
- C) III ve IV
- D) Yalnız II
- E) Yalnız I

S.8) Aşırı tatlı yeme isteği sebebiyle doktor muayenesine giren hastaya tip II diyabet teşhisi konmuştur.

Yukarıda yer alan bilgi dikkate alındığında aşağıdakilerden hangisi söylenemez?

- A) Homeostazi zaman içinde birtakım faktörlere bağlı olarak bozulabilir.
- B) Bu hastalık genetik yolla sonraki nesillere aktarılır.
- C) Hastanın uygun olmayan beslenme tarzına sahip olduğu düşünülebilir.
- D) Tedavi için insülin hormonunun direnci ortadan kaldırılmalıdır.
- E) Hastalık obezite kaynaklı ortaya çıkmış olabilir.

S.9)

- I. Protein
- II. Protein ayırıcı
- III. Protein yıkan enzim
- IV. Aminoasit
- V. Aminoasit ayırıcı

"Aminoasitler proteinlerin yapı taşlarıdır." hipotezini kanıtlamak için düzenlenen bir deneyde, yukarıdakilerden hangilerinin birlikte kullanılması gerekmektedir?

- A) I ve II
- B) I ve III
- C) III ve I
- D) III ve V
- E) I, III ve V

S.10) Aşağıdakilerden hangisi DNA ve RNA'nın ortak özelliklerinden biridir?

- A) Her birinin yapısında tüm pirimidin baz çeşitleri yer alır.
- B) Her iki molekül de nükleotit polimeridir.
- C) Her zaman zarfı organel içerisinde bulunurlar.
- D) Zincirlerindeki pürin ve pirimidin bazlarının sayıları her zaman birbirine eşittir.
- E) Hücre döngüsünde replikasyon geçirirler.

S.11)

- I. Klorofil pigmentinin yapısına katılır.
- II. Hemoglobin pigmentinin yapısına katılır.
- III. Tiroksin hormonunun yapısına katılır.

Yukarıda görevleri belirtilen mineral çeşitleri aşağıdakilerden hangisinde doğru verilmiştir?

|    | I         | II        | III   |
|----|-----------|-----------|-------|
| A) | Demir     | Magnezyum | İyot  |
| B) | Magnezyum | Bakır     | Demir |
| C) | Demir     | Bakır     | İyot  |
| D) | İyot      | Magnezyum | Demir |
| E) | Magnezyum | Demir     | İyot  |

S.12) Aşağıda verilen mineral çeşitleri ve görevleri ile ilgili eşleştirmelerden hangisi yanlıştır?

- A) Kalsiyum → Kemik ve diş yapısına katılma
- B) Fosfat → DNA, RNA ve ATP yapısına katılma
- C) Sodyum → pH ve su dengesini sağlama

- D) Klor → Mide özsuyu oluşumunda  
E) Çinko → Çizgili kaslardaki miyogloblin yapısına katılma

S.13) Hücre zarının yapısında en fazla bulunan lipit çeşidi aşağıdakilerden hangisidir?

- A) Glikolipit B) Steroit C) Fosfolipit  
D) Kolesterol E) Trigliserit

S.14)

- x – Riboz  
y – Glikoz  
z – Galaktoz  
k – Deoksiriboz  
m – Fruktoz

Yukarıda bazı karbonhidrat çeşitleri verilmiştir.

Buna göre,

- I. x ve y  
II. y ve z  
III. z ve m  
IV. y ve m  
V. x ve k

ikililerinden hangilerinin birleşmesi bir disakkarit oluşumu ile sonuçlanabilir?

- A) I ve III B) II ve IV C) I, II ve V  
D) II, III ve IV E) II, III, IV ve V

S.15) Aşağıdaki yiyecek guruplarından hangisinde dengeli beslenme için gerekli besinler, diğerlerine göre daha fazla bulunmaktadır?

- A) Nohut – pilav – yoğurt  
B) Etili nohut – pilav – baklava  
C) Etili nohut – pilav yoğurt  
D) Etili nohut – pilav – salata  
E) Köfte – patates – pilav – baklava

S.16) Aşağıda verilen özelliklerden hangisi doymuş yağ asitlerinde görülürken doymamış yağ asitlerinde görülmez?

- A) Ortam pH'sını düşürme  
B) Karbon atomları arasında çift bağ bulundurma  
C) Oda sıcaklığında katı hâlde bulunma  
D) Kimyasal sindirime uğramama  
E) Nötral yağların yapısına katılabilme

S.17) Hormonlar;

- I. Hücrelerde kendilerine özgü reseptörlerin bulunabilmesi  
II. Organik yapıda olma,  
III. Düzenleyici olarak görev yapma,  
IV. Bazı çeşitlerinin sindirilebilmesi  
Özelliklerinin hangileri yönüyle vitaminlere benzerler?

- A) I ve IV B) II ve III C) I, II ve IV  
D) I, III ve IV E) II, III ve IV

S.18) Bitkilerde bazı minerallerin bitki gelişimi üzerine etkisi ile ilgili bir tablo aşağıda verilmiştir. Tablodaki her bir "+" sembolü birim miktar gelişmeyi ifade etmektedir.

| Mineral madde durumu | Bitki gelişimi |
|----------------------|----------------|
| K + N + Cl + Fe + Ca | +++++          |
| K yetersiz           | ++             |
| Cl yetersiz          | ++++           |
| Fe yetersiz          | ++             |
| Ca yetersiz          | +++            |
| N yetersiz           | +              |

Tablodaki bilgilere göre bitkinin gelişmesi üzerine en etkili olan mineral aşağıdakilerden hangisidir?

- A) K B) Cl C) Fe  
D) Ca E) N

S.19)



Vitaminlerin sınıflandırılması yukarıda verilmiştir. Buna göre;

Vitamin grupları ile ilgili aşağıda verilenlerden hangisi yanlıştır?

| Suda Çözünenler               | Yağda Çözünenler                     |
|-------------------------------|--------------------------------------|
| A) Depolanmazlar              | Depo edilirler.                      |
| B) Fazlası idrarla atılır     | Fazlası depolanabilir.               |
| C) Eksikliği hemen anlaşılır. | Eksikliğinin anlaşılması uzun sürer. |
| D) Emilimi sulu ortamda olur. | Emilimi yağlı ortamda olur.          |
| E) Ototroflar üretmezler      | Ototroflar üretirler.                |

S.20) Suda ve yağda çözünen vitaminlerin,

- I. Depolanabilmeleri  
II. Düzenleyici olmaları  
III. Organik yapıda olmaları  
IV. Sindirilmemeleri

özelliklerinden hangileri ortak değildir?

- A) Yalnız I B) Yalnız IV C) I ve III  
D) II ve IV E) II, III ve IV

5.21)



Tarhananın yapımı sırasında mayalanması protein, karbonhidrat ve yağların bakteri kültürleri tarafından ön sindirime uğraması tarhananın daha kolay sindirilmesi ve daha besleyici özellik kazanmasını sağlamaktadır. Tarhananın glikemik indeksinin 20 olduğu bilinmektedir. Glikemik indeks, besinlerin vücuda alındığında kan şekerini yükseltme hızını ifade eden indekstir. Glikemik indeksi düşük besinler, kan şekerini yavaş yükselterek özellikle şeker hastalığına karşı koruyucu etki sağlar. Ayrıca tarhananın probiyotik özellikte olduğu düşünülmektedir. Probiyotikler besinlerle belirli miktarlarda alındığında bağırsak florasını dengeleyip insan sağlığını olumlu yönde etkileyen canlı organizmalardır. Tarhana içerdiği lif ile kanın kolesterol seviyesinin dengede tutulmasına yardımcı olur ve kolon kanseri riskini azaltır.

Yukarıda tarhana ile ilgili verilenlerden hangisi çıkarılamaz?

- A) Sindiriminin daha kolay olması
- B) Glikemik indeksinin düşük olması
- C) Probiyotik bakımından zengin besin olduğu
- D) Kan kolesterol seviyesini dengede tuttuğu
- E) Bazı mikroorganizmalara karşı antibiyotik özellik gösterdiği

5.22)

İnsanlarda hormonlarla ilgili;

- I. Büyüme, farklılaşma ve metabolizma gibi fizyolojik olayların düzenlenmesinde görev alırlar.
- II. Endokrin bezlerden salgılanırlar.
- III. Tamamı protein yapılı olup DNA kontrolünde sentezlenirler.

Yargılarından hangileri yanlıştır?

- A) Yalnız I
- B) Yalnız II
- C) Yalnız III
- D) I ve II
- E) II ve III

5.23)

Aşağıda şekli verilen bir tRNA'nın numaralandırılan kısımları ile ilgili;



- I. 1 nolu kısım aminoasit bağlanan ucudur.
- II. 2 nolu kısım ribonükleotitler arasındaki zayıf hidrojen bağlarıdır.
- III. 3 nolu kısım tRNA'nın çeşidini belirleyen 3'lü nükleotit olan antikodonudur.

Yargılarından hangileri doğrudur?

- A) Yalnız I
- B) Yalnız II
- C) Yalnız III
- D) II ve III
- E) I, II ve III

5.24)

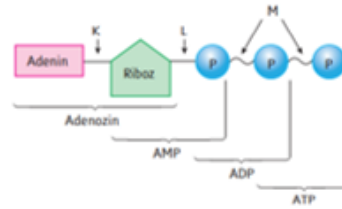

Bir ATP molekülündeki K, L ve M ile gösterilen bağlar aşağıdakilerden hangisinde doğru verilmiştir?

|    | K        | L        | M        |
|----|----------|----------|----------|
| A) | Glikozit | Ester    | Fosfat   |
| B) | Peptit   | Ester    | Glikozit |
| C) | Ester    | Glikozit | Fosfat   |
| D) | Glikozit | Fosfat   | Ester    |
| E) | Fosfat   | Peptit   | Peptit   |

S.25) Aşağıda bir pH metre verilmiştir.

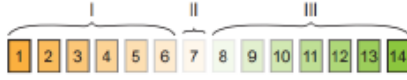

Buna göre I, II ve III bölgelere ait örnekler hangi seçenekte doğru verilmiştir?

| I                | II         | III           |
|------------------|------------|---------------|
| A) Karbondioksit | Amonyak    | Su            |
| B) Elma          | Maden suyu | Kahve         |
| C) Amonyak       | Su         | Karbondioksit |
| D) Gazoz         | Su         | Brokoli       |
| E) Gazoz         | Amonyak    | Elma          |

TEST BİTTİ

