



Validating Suburban Teachers' Commitments: Let's Appreciate Their Blood, Sweat, and Tears

Nor Hasimah Ismail

Dr., Universiti Utara Malaysia, Malaysia, nor_uum@yahoo.com

Mat Rahimi Yusof

Universiti Utara Malaysia, Malaysia, mrahimiy@uum.edu.my

Mohd Yusri Ibrahim

Universiti Malaysia Terengganu, Malaysia, yusri@umt.edu.my

Mohd Sofian Omar Fauzee

Universiti Utara Malaysia, Malaysia, mohdsofian@uum.edu.my

Rosniza Ismail

SK Kampung Berangan, Malaysia, fasbiruu@gmail.com

The purpose of this study is to create a model for measuring suburban teachers' commitments in Kelantan, Malaysia. In this quantitative analysis, a cross-sectional study design was adopted. A total of 182 teachers from elementary schools in the Pasir Puteh district of Kelantan were selected using a stratified random sample procedure to complete the online questionnaire. The data was gathered and evaluated using SEM AMOS, which revealed that 19 of the 24 indicated behaviours are acceptable. Finally, the study's findings effectively verified and validated three constructs: affective commitment, normative commitment, and continuance commitment, and effectively developed a measurement model of suburban teachers' commitments in Kelantan. The outcomes of this study can be used to assess teachers' commitment to their profession. Following that, the Ministry of Education (MOE) can design relevant courses or workshops to assist instructors in gaining a better knowledge of instructors. dedication Future scholars are also encouraged to do research in other Malaysian states so that the study's findings may be generalised.

Keywords: teacher commitment, affective commitment, normative commitment, continuance commitment, suburban teachers

INTRODUCTION

The government's aim, as stated in the national curriculum goals, is to ensure that the next generation is stable and capable of mastering new skills by the twenty-first century. This situation is very similar to the six student aspirations found in the Malaysia

Citation: Ismail, N. H., Yusof, M. R., Ibrahim, M. Y., Fauzee, M. S. O., & Ismail, R. (2022). Validating suburban teachers' commitments: Let's appreciate their blood, sweat, and tears. *International Journal of Instruction*, 15(3), 103-116. <https://doi.org/10.29333/iji.2022.1536a>

Educational Blueprint, which can help students become more innovative, and teachers should be in charge of bringing these aspirations to fruition (Roselizam et al., 2020). Educators must fully understand, appreciate, and implement all policies and improvements made (Kementerian Pendidikan Malaysia, 2013; Roselizam et al., 2020).

In this situation, teachers must emphasise the importance of teacher commitment as a critical component. According to studies, the improvement in a school's performance is directly linked to teachers' work engagement (Munian & Hasan, 2020). As a result, if the engagement of teachers is given special attention in producing human capital as desired by the National Education Philosophy, the MOE's aim of producing human beings who can compete globally can be realised. As a result, teachers' commitment is critical and should be prioritised in order to ensure students' success (Kasa et al., 2020; Kementerian Pendidikan Malaysia, 2015; Zee & Koomen, 2016).

Research Background

"Let us appreciate their blood, sweat, and tears." This is the message that needs to be conveyed in recognition of a teacher's sacrifice and devotion. Commitment is the ability to understand oneself and a task from both internal and external strengths, which drives a sense of responsibility towards a task until it is completed with sincerity. (Saragih & Suhendro, 2020). Commitment also generally requires the loyalty of every person, as well as a full sense of duty, to understand the organisation's vision and mission.

Employees who have been with the company for a long time have a higher level of organizational loyalty than those who have been with the company for a short time. Employees who are highly committed have better work attitudes and longer working hours compared to those who are less committed (Don et al., 2021; Malthis, Robert L. Jackson, 2001; Slocum & Hellriegel, 2011). Commitment is interrelated with behaviours such as attending work on time, attending school when necessary, and often promoting work achievement (Munian & Hasan, 2020).

Similarly, in the context of educational organisations, teacher commitment is a variable often studied by researchers. Teachers' commitment to the school underpins the concept of the views, acceptance as well as their attempts to achieve school goals. On the other hand, teachers' commitment to students is related to their involvement and responsibilities in all student learning activities. This is in contrast to the concept of teachers' commitment to teaching that refers to their readiness to provide effective instruction, demonstrating enthusiasm and allocating extra time to students. Finally, teachers' dedication to the profession is regarded as a motivating factor, in which the participation in work could improve their professional skills, knowledge, and teaching abilities (Jusoh et al., 2020; Karakuş & Aslan, 2009; Nik Mustafa et al., 2015).

However as a result, many factors influence teacher commitment such as school leader leadership, school climate, teacher workload, teacher attitude, and student discipline (Kasa et al., 2020; Lela et al., 2020; Mustafa et al., 2019). Successful leaders are usually able to increase teacher engagement in their schools (Don et al., 2021; Setyaningsih & Sunaryo, 2021). This quality of leadership becomes a measure because imperial studies show that wise school leaders are capable of producing committed teachers (Amhag et

al., 2019; Raman & Shariff, 2017). In addition to school leadership, the school climate has a significant impact on teachers' commitment (Raman & Shariff, 2017; Saidin et al., 2020).

Teachers with high commitment would dedicate themselves in school to their students' success (Jusoh et al., 2020; Nik Mustafa et al., 2015). Teacher commitment is regarded as one of the factors influencing teachers the capability to innovate and incorporate new ideas into teaching practice (Jones et al., 2014). High-commitment teachers will contribute to student's academic success (Jusoh et al., 2020). Uncommitted teachers will cause big issues for the school administration and principals (Hallinger et al., 2014).

Teachers should have a high awareness that job satisfaction and commitment can contribute a positive impact on school should play a proactive role by creating a conducive school culture and climate to increase the level of work commitment of teachers who can form an excellent organisation performance and improve job performance (Jusoh et al., 2020; Mohd Yusri & Mohd Hazlami, 2015; Munian & Hasan, 2020; Saragih & Suhendro, 2020).

Yet the results of the study show that some teachers who do not understand the importance of engagement in schools do not focus particular attention on the work of the education system, and they can run smoothly and effectively. In reality, most teachers feel that commitment is part of professional values by setting aside commitment as an obligation which is a requirement for teacher success (Gu & Day, 2007). Teacher commitment is not only directly linked to school and student performance, but commitment is also related to teaching and learning problems, school success, and overall well-being (Day, 2008; I. Park, 2005).

However, in addition to teaching, teachers' dedication is affected by their workload, which puts pressure on them and affects their performance. Teachers who skipped work and were late for work, misused leave permission letters, and tended toward negative work habits (Billy & Taat, 2020) also affected internal emotions that will affect teachers' commitments (Munian & Hasan, 2020). Therefore, the issue of teacher commitment should be highlighted because affects the teaching profession's dignity. Thus, this study generally aims to analyse the constructs and indicators or behaviours that are accepted and validated in measuring teachers' commitments.

Organisational Commitment Theory

As we can see, relate to the previous study commitment in organisation has spanned over two centuries and still ongoing related to individual performance and commitment, organisational performance, and effectiveness in organisations (Sharina et al., 2014; Vazirani, 2010). Commitment refers to work commitment, career commitment, and organisational commitment. Individuals' commitment relates to the individual's strength and engagement in the organisation, whereas organisational commitment relates to the organization's commitment to the individual. Meyer and Allen (1997) describe organisational commitment as a psychological term that describes an employee's relationships with the organisation and has implications for an individual's decision to continue working there (Retnowati et al., 2021).

Employees who commit to the organisation will be better able to survive as members of the organisation when compared to employees who do not commit to the organisation. Several models of organisational commitment have been developed as findings of the study (Meyer et al., 1993; Mustafa et al., 2019; Steers, 1977). However, the Meyer and Allen (1991) model were popular in the study because it is the most common among previous researchers (Culpepper, 2000; Nik Mustafa et al., 2015; Vandenberghe & Tremblay, 2008) as shown in figure 1.

Allen and Meyer (1984) distinguish three categories of organisational commitment: affective, Continuance, and normative. Affective commitment is described as emotional feelings about the organisation's values (Robbins & Judge, 2013). It may also be defined as an individual's emotional attachment to and engagement throughout the organisation (Meyer et al., 2002).

Normative commitment is related to the employees' sense of obligation toward the organisation (Meyer et al., 2002; Robbins & Judge, 2013). Whereas Continuance commitment is concerned with an individual's judgement of the losses someone will face if they leaves the organisation or someone who considers the costs incurred if the organisation is left (Mahmud et al., 2019). Individuals who work based on this Continuance commitment will be able to stay in the organisation because indeed they do so. After all, there is no other option (Meyer et al., 2002).

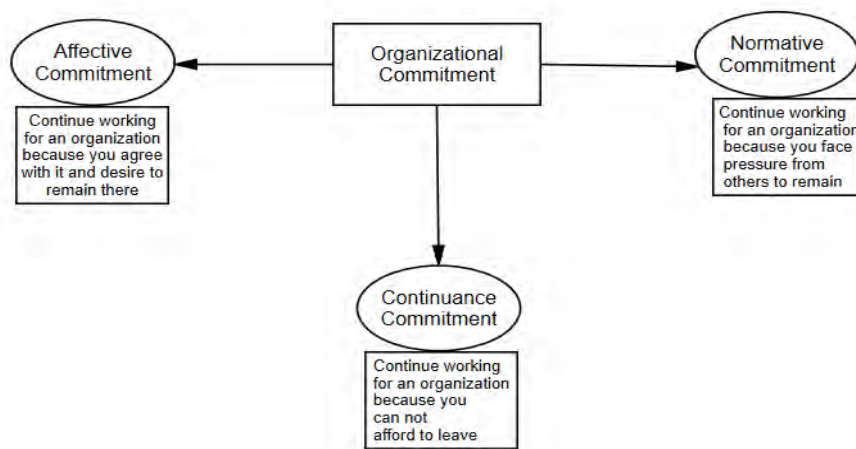

Figure 1
Modification from Meyer and Allen commitment model

METHOD

This research used a cross-sectional quantitative design. The Structural Equation Model (SEM) AMOS version 26 was used to analyse and evaluate the suggested teacher commitment measurement model. The researchers chose this technique because it has been applied effectively in various fields, including healthcare, psychology, marketing,

finance, and tourism management (Lu et al., 2007). A total of 200 online surveys modified from Meyer and Allen (1991) were delivered through WhatsApp to the chosen respondents from a suburban teacher in Pasir Puteh District of Kelantan in Malaysia. Additionally, data normalisation was conducted before the analysis to detect any outliers. As a result, the Mahalanobis distance value was set at a greater value than 143.44 as an outlier's data, and the Chi-squares Distribution Table at the significant level, $p < 0.001$ (Tabachnick and Fidell, 2001). Finally, a total of 182 complete responses proceeded for further analysis.

The procedure of confirmatory factor analysis (CFA) approach was used to develop the measurement model. The decision process took into account four essential parts of CFA: loading factor, convergent validity, composite reliability, and discriminant validity. The items, constructs and variables will be consider and accepted as model's elements if the regression weight (β) for factors loading was 0.708 and above, the average variance extracted (AVE) for the convergent validity was 0.5 and above, the composite reliability (CR) value was 0.708 and above, and value of AVE's square root was greater than the inter-correlation values between items or between constructs for discriminant validity (Elastika et al., 2021; Fornell & Larcker, 1981; Hair et al., 2012; Zainuddin, 2015). Even though the required factor loading value was 0.708 or higher, a regression coefficient of more than 0.4 items was still acceptable if the AVE value was greater than 0.5. (Hair et al., 2012; Yusof et al., 2019).

Some fit indexes were observed to determine the fitness between the field data and the proposed model, such as the ratio of Khi square, CFI, NFI, PCFI, PNFI, and RMSEA. Once the values of Khi square 5, CFI and NFI > 0.90 , PCFI and NFI > 0.50 , and RMSEA 0.1 were obtained, the model was considered fit (Meyers et al., 2013). When at least one of each category of absolute, relative, and parsimony indexes was fit, the final model was considered fit.

FINDINGS

Preliminary Result

Gravetter et al. (2018) and Chua (2009) mentioned that the acceptable skewness and kurtosis is between ± 1 . Meanwhile, Tabachnik and Fidell (2007) suggested a value between ± 2 for large sample sizes. Table 1 shows the results of skewness and kurtosis. As shown, the values are between the acceptable range of ± 2 . Therefore, all the variables are considered normally distributed, and further parametric analysis may be carried out.

Table 1
The preliminary result

	Mean	SP	Skew	Kurt.
Affective	4.010	.612	-.391	1.913
Continuous	3.467	.691	.039	.288
Normative	3.520	.760	-.549	.939
Teachers' Commitments	3.688	.586	-.086	2.04

The Regression Weight

The value of the critical ratio (C.R) and the significance of Chi-Square use to confirm the factor. The C.R value must be greater than ± 1.96 for the proposed factor to be accepted (Chua, 2014; Hair et al., 2010). Table 3 shows that all the C.R value of the teachers' commitments construct exceeds ± 1.96 . This finding indicates the Normative commitment C.R at 8.562 ($p=.000$), Affective commitment C.R at 7.508 ($p=.000$), and Continuance commitment C.R at 8.223 ($p=.000$). Thus, all the constructs are contributing significantly to the proposed factors. As a result, it was shown that all three constructs strongly measured teachers' commitment in school.

Table 2
Regression coefficient result

			Estimate	SE	C.R. ± 1.96	P .000	Result
Normative commitment	<---	Teachers' commitment	.713	.083	8.562	***	Significant
Affective commitment	<---	Teachers' commitment	.476	.063	7.508	***	Significant
Continuance commitment	<---	Teachers' commitment	1.000		Reference point		

The Discriminant Validity

Table 3 shows the result of the discriminant validity for all the constructs. Discriminant validity is achieved when the square root of the AVE's values is greater than the correlation value between the constructs (Zainuddin, 2015). Therefore, as shown in Table 3, the Normative Commitment had a value of 0.738, higher than the Continuance and Affective Commitment. Meanwhile, the Continuance Commitment also had a value greater than Affective Commitment at 0.748 compared to 0.725. As a result, the suggested constructs in this model were deemed to fulfil the discriminant validity criteria.

Table 3
Discriminant validity: Inter- Construct Correlation (\sqrt{AVE} shows in diagonal)

	Normative	Continuance	Affective
Normative Commitment	0.738		
Continuance Commitment	0.676	0.748	
Affective Commitment	0.69	0.725	0.79

The Convergent Validity

As we can see in Table 4 show the result of the measurement model through convergent validity. According to David F. L. and Fornell. C., (1981), Hair et al., (2012), Ibrahim, Yusof, Morni, et al., (2019), Meyers et al., (2013), Yusof et al., (2019), and Zainuddin (2015) suggested that all items, constructs, and variables of the model will be accepted when regression weight for every factor loading (exceed 0.708), composite reliability (exceed 0.708), Average Variance Extracted (AVE) (exceed 0.5), and square root AVE (\sqrt{AVE}) for discriminant validity biggest than the value of correlation between an item

and construct. This study found that items, constructs, and variable are accepted except some items because of low factor loading.

The FL, C.R, AVE, and $\sqrt{\text{AVE}}$ for Affective Commitments (FL:0.54–0.91, C.R: 0.925, AVE:0.587, $\sqrt{\text{AVE}}$:0.766), Continuance Commitment (FL:0.34–0.81, C.R:0.820, AVE: 0.359, $\sqrt{\text{AVE}}$:0.599), and Normative Commitment (FL:0.62–0.91, C.R: 0.892, AVE: 0.545, $\sqrt{\text{AVE}}$: 0.738).

Table 4
Convergent validity: Regression weight for teachers' commitment construct

Construct	Item	FL	C.R > .708	AVE > 0.5	$\sqrt{\text{AVE}}$
Affective Commitment	C1	0.66	0.925	0.587	0.766
	C2	0.74			
	C3	0.65			
	C4	0.54	low factor loading item was removed		
	C5	0.91			
	C6	0.91			
	C7	0.9			
	C8	0.81			
	C9	0.68			
Continuance Commitment	C10	0.8	0.802	0.359	0.599
	C11	0.4	low factor loading item was removed		
	C12	0.7			
	C13	0.73			
	C14	0.34	low factor loading item was removed		
	C15	0.46	low factor loading item was removed		
	C16	0.77			
	C17	0.36	low factor loading item was removed		
Normative Commitments	C18	0.71	0.892	0.545	0.738
	C19	0.62			
	C20	0.91			
	C21	0.73			
	C22	0.79			
	C23	0.71			
	C24	0.67			

However, low factor loading item should be deleted (Zainuddin, 2015). According to Hair, et al., (2010) the external load value ≥ 0.4 is acceptable if the AVE value reaches the recommended value of >0.5 . Referring to table 5, items C4 (Affective Commitments), and C11, C14, C15, C17 (Continuance Commitment) are deleted due to low factor loading.

Table 5
Deleted item for affective commitment, and continuant commitment

Constructs	Items	Indicators/behaviours	FL
Affective Commitments	C4	I do not feel obligated to attend another school	0.54
	C11	I was concerned about what would happen if I left my job without a replacement.	0.4
Continuant Commitment	C14	I didn't have a lot of choices when it came to quitting my job	0.34
	C15	If I leave this school, there's a good chance I won't be able to find work	0.46
	C17	Employees nowadays, in my opinion, move from one school to another far too often	0.36

After items were deleted, the value of factor loading, composite Average Variance Extracted, and square root AVE are increasing as shown in table 6.

Table 6
Values after delete items

Construct	Item	FL	C.R > .708	AVE > 0.5	$\sqrt{\text{AVE}}$
Affective Commitment	C1	0.662	0.929	0.624	0.79
	C2	0.738			
	C3	0.645			
	C5	0.913			
	C6	0.905			
	C7	0.906			
	C8	0.81			
	C9	0.683			
	C10	0.813			
Continuant Commitment	C12	0.662	0.835	0.559	0.748
	C13	0.733			
	C16	0.775			

Next Table 7 shows the constructs and numbers of indicators that were accepted. They are three constructs, and 19 behaviours were accepted to measure the teachers' commitments.

Table 7
Summaries of accepted constructs and indicators

Constructs	Suggested Indicators	Accepted Indicators
Normative commitment	9	8
Affective commitment	8	4
Continuance commitment	7	7
Total	24	19

The Final Suburban Teachers' Commitments Measurement Model

Several fit indices, including Chi Square (CMIN), CFI, RMSEA, PNFI, and PCFI, were used in this study to justify the model's fitness. When the significant values of Chi Square (CMIN) exceeded 0.05, the hypothesis model was judged fit with the obtained data. When the CFI exceeds 0.90, the hypothesis model is considered fit, however

values between 0.80 and 0.89 are still within the acceptable limit. The acceptable RMSEA value is less than 0.08 (Byrne, 2010; Ibrahim, Yusof, Yaakob, et al., 2019). The PCFI and PNFI index values must exceed 0.5 for the fit of the model (Byrne, 2013; Elastika et al., 2021; Ibrahim, Yusof, Morni, et al., 2019; Meyers et al., 2013). If at least one of each category of absolute relative and parsimony indices was fit, the final model was considered fit. According to table 8, all indices for each category were fit.

Table 8
The fitness indexes for the Suburban Teachers' Commitments measurement model

Categories	Index's	Value	Result
Absolute	Ratio	2.648	The required level has been achieved.
	RMSEA	0.095	The required level has been achieved.
Relative	CFI	0.903	The required level has been achieved.
	PCFI	0.771	The required level has been achieved.
Parsimonious	PNFI	0.729	The required level has been achieved.

Note:
 RMSEA : Root Mean Square Error of Approximation
 CFI : Comparative Fit index
 PCFI : Parsimony Comparative Fit index
 PNFI : Parsimony Norm Fit index

Finally, this study successfully developed the final measurement model of suburban Teachers' Commitments. This model consists of 19 indicators or behaviours and three constructs namely Affective Commitments, Continuance Commitment, and Normative Commitment as shown in Figure 2.

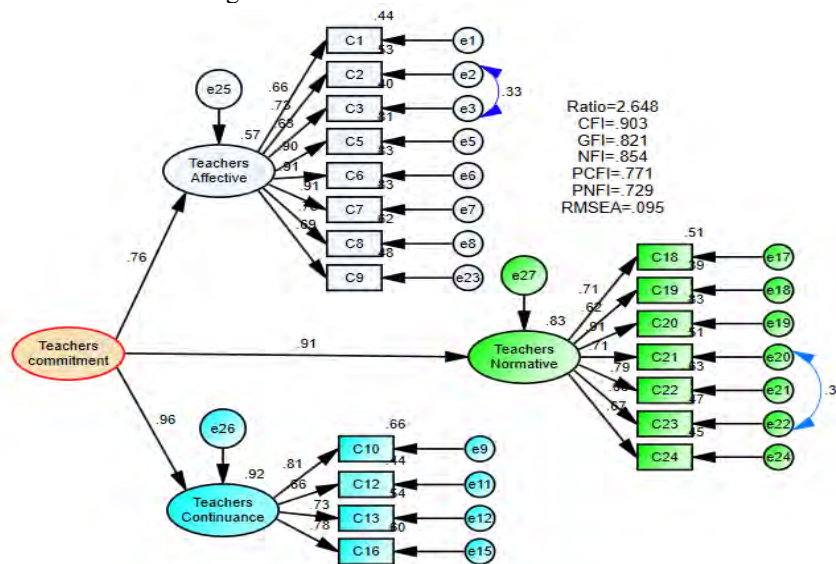

Figure 2
The final measurement Suburban Teachers' Commitments model

DISCUSSION

Subordinate must demonstrate their commitment to the organisation by living it. Similarly, with the organisation of Education, teacher commitment is one of the factors that influence the effectiveness of the organisation and the well-being of students. A study was using Meyer and Allen's (1991) organisational commitment model conducted on suburban teachers in Pasir Puteh district, Kelantan successfully identified and confirmed three categories of teacher commitment, namely affective commitment, normative commitment, and continuous commitment. However, the findings of the study successfully accepted and validated 19 different behaviours with 24 behaviours by Meyer and Allen (1991).

The rejection behaviour, such as "I will not feel attached to another school," represents the teacher's loyalty to the organisation. Thus, based on the behaviours accepted in the study's findings, it can be concluded that teachers continue to have a high level of commitment. In this case, teachers with a high level of commitment have a better work attitude and a longer and more flexible working period than less committed teachers (Malthis, Robert L. Jackson, 2001)

Indirectly, this behaviour indicates a high level of commitment among suburban teachers in Pasir Puteh, Kelantan. Teachers with a high level of commitment can be identified by habits such as arriving at work on time, attending school when necessary, and consistently delivering excellent work results. Munian and Hasan (2020) and will dedicate themselves to their student's success at school by continuously innovating and incorporating new concepts into teaching practice. The findings of this study also show that teachers understand commitment better than is stated, as most teachers believe commitment is a part of their professional values, rather than an obligation that is an important condition for teacher success (Gu & Day, 2007).

According to the findings of this study, affective commitment, normative commitment, and continuous commitment are reflect the psychological state of employees and organisations. In the context of education, this commitment has significant implications for teachers' decisions to remain loyal or leave the school. Commitment to the organisation, on the other hand, is determined by the psychology of each individual. As a result, all teachers should value these three dimensions in order to increase teachers' commitment to the school. This is because previous research has shown that student excellence is closely related to teacher commitment (Kasa et al., 2020).

CONCLUSION

Generally, this study has successfully developed a measurement model for measuring suburban teachers' commitment in Pasir Putih, District, Kelantan. The study's findings also successfully confirmed 19 indicators or behaviours that contribute to the teachers' commitment. We anticipate that the outcomes of this research will assist specific parties in measuring the commitment of teachers via the use of a set of questions that have been tested and shown to be effective. At the same time, school administrators might utilise the findings of this research to establish a healthy school climate and culture that would encourage teachers to remain committed to their jobs in the classroom. Finally, future

researchers are invited to replicate this study in other Malaysian states in order to ensure that the results are applicable across a broader range of contexts.

ACKNOWLEDGEMENT

We are grateful to Research and Innovation Management Center (RIMC), Universiti Utara Malaysia was support and funded this research.

REFERENCES

- Amhag, L., Hellström, L., & Stigmar, M. (2019). Teacher Educators' Use of Digital Tools and Needs for Digital Competence in Higher Education. *Journal of Digital Learning in Teacher Education*, 35(4), 203–220. <https://doi.org/10.1080/21532974.2019.1646169>
- Billy, L. J., & Taat, M. S. (2020). Kepuasan Komunikasi Guru Sekolah Rendah: Satu Kajian Tinjauan di Bahagian Pedalaman Atas Sabah. *Malaysian Journal of Social Sciences and Humanities (MJSSH)*, 5(11), 159–166. <https://doi.org/10.47405/mjssh.v5i11.561>
- Byrne, B. M. (2010). *Structural Equation Modelling with AMOS: Basic Concepts, Applications and Programming* (2nd ed.). Routledge, Taylor and Francis Group.
- Byrne, B. M. (2013). *Structural Equation Modeling with LISREL, PRELIS and SIMPLIS: Basic Concepts, Applications and Programming*. Psychology Press.
- Chua, Y. P. (2014). *Kaedah dan statistik penyelidikan buku 5: Ujian regresi, analisis faktor dan analisis SEM*. Mc Graw Hill Education.
- Culpepper, R. A. (2000). A test of revised scales for the Meyer and Allen (1991) three-component commitment construct. *Educational and Psychological Measurement*, 60(4), 604–616. <https://doi.org/10.1177/00131640021970754>
- David F. L., Fornell, C., Larcker, C. F., & F., D. (1981). Evaluating Structural equation models with unobservable variables and measurement error. *Journal of Marketing Research*, 18(1), 39–50.
- Don, Y., Faiz, M., Yaakob, M. F. M., Wanhanafi, W. R., Yusof, M. R., Wan Hanafi, W. R., Yusof, M. R., Kasa, M. D., Omar-Fauzee, M. S., & In-Keeree, H. K. (2021). Challenges for using organizational climate tools for measuring teacher job satisfaction. *International Journal of Evaluation and Research in Education*, 10(2), 465–475. <https://doi.org/10.11591/ijere.v10i2.20703>
- Elastika, R. W., Sukono, & Dewanto, S. P. (2021). Analysis of factors affecting students' mathematics learning difficulties using sem as information for teaching improvement. *International Journal of Instruction*, 14(4), 281–300. <https://doi.org/10.29333/iji.2021.14417a>
- Fadli Anshary Rumasukun, S., Rante, Y., Wambrauw, O. O., & Elita Bharanti, B. (2015). The Influence of Human Resource Management Strategy and Competence on Employee Performance with the Mediation of Work Motivation, Organizational Commitment and Work Culture (Study at the Official of Management of Communication and Information Technology o. *International Journal of Business and*

Management Invention ISSN (Online, 4(8), 2319–8028. www.ijbmi.org

Fornell, C., & Larcker, D. F. (1981). Fornell, C. and Larcker, D.F. (1981), "Evaluating structural equation models with unobservable variables and.pdf. *Journal of Marketing Research, XVIII*(February), 39–50.

Gu, Q., & Day, C. (2007). Teachers resilience: A necessary condition for effectiveness. *Teaching and Teacher Education, 23*(8), 1302–1316. <https://doi.org/10.1016/j.tate.2006.06.006>

Hair, J. F., Black, W. C., Babin, B. J., & Anderson, R. E. (2010). *Multivariate Data Analysis* (Seventh Ed). Pearson Prentice Hall.

Hair, J. F., Sarstedt, M., Pieper, T. M., & M., C. R. (2012). The Use of Partial Least Squares Structural Equation Modeling in Strategic Management Research: A Review of Past Practices and Recommendations for Future Applications. *Long Range Planning, 45*(5–6), 320–340.

Hallinger, P., Heck, R. H., & Murphy, J. (2014). *Teacher evaluation and school improvement : An analysis of the evidence. 5–28. https://doi.org/10.1007/s11092-013-9179-5*

Ibrahim, M. Y., Yusof, M. R., Morni, M. M., Kasawani, I., Sinin, A. M., & Mahadi, M. Z. (2019). The measurement model of virtual instructional leadership : Confirmatory factor analysis approach. *The Journal of Social Sciences Research, 5*(1985), 154–158.

Ibrahim, M. Y., Yusof, M. R., Yaakob, M. F. M., & Othman, Z. (2019). Communication Skills : Top Priority of Teaching Competency. *International Journal of Learning, Teaching and Educational Research, 18*(8), 17–30. <https://doi.org/10.26803/ijlter.18.8.2>

Jones, S., Harvey, M., & Lefoe, G. (2014). A conceptual approach for blended leadership for tertiary education institutions. *Journal of Higher Education Policy and Management, 36*(4), 418–429. <https://doi.org/10.1080/1360080X.2014.916469>

Jusoh, M. M., Ismail, S. N., & Abdullah, A. S. (2020). Kepuasan Kerja Dan Komitmen Guru Sekolah Menengah Cemerlang Di Kelantan. *Jurnal Kepimpinan Pendidikan, 7*(1), 77–90. muslizabtmatjusoh78@gmail.com

Karakuş, M., & Aslan, B. (2009). Teachers' commitment focuses: A three-dimensioned view. *Journal of Management Development, 28*(5), 425–438. <https://doi.org/10.1108/02621710910955967>

Kasa, M. D., Shamsuddin, M. F., Yaakob, M. F. M., Yusof, M. R., & Sofian, F. N. R. M. (2020). Exploring the influence of a principal's internalized moral perspective towards teacher commitment in Malaysian secondary schools. *Journal of Education and E-Learning Research, 7*(3). <https://doi.org/10.20448/JOURNAL.509.2020.73.323.333>

Kementerian Pendidikan Malaysia. (2013). *Pelan Pembangunan Pendidikan Malaysia 2013 - 2025 (Pendidikan Pra Sekolah hingga Lepas Menengah)*. Kementerian Pendidikan Malaysia.

Kementerian Pendidikan Malaysia. (2015). *Pelan Pembangunan Pendidikan Malaysia*

Laporan Tahunan 2014.

- Lela, N., Hanani, N., Rapani, A., Ismail, Z., Suriati, A., & Yusof, M. R. (2020). Accounting teacher self efficacy , usage , teaching preference and skill towards virtual learning environment in education. *International Journal of Advanced Science and Technology*, 29(6), 249–264.
- Mahmmud, N. A., Hassan, H. B., & Shaharudinc, S. (2019). Employee commitment to change: A literature review. *International Journal of Innovation, Creativity and Change*, 7(4), 248–261.
- Malthis, Robert L. Jackson, J. H. (2001). *Human Resouce Management*. PT Salemba Emban Patria.
- Meyer, J. P., Allen, N. J., & Smith, C. A. (1993). Commitment to Organizations and Occupations: Extension and Test of a Three-Component Conceptualization. *Journal of Applied Psychology*, 78(4), 538–551. <https://doi.org/10.1037/0021-9010.78.4.538>
- Meyer, J. P., Stanley, D. J., Herscovitch, L., & Topolnytsky, L. (2002). Affective, continuance, and normative commitment to the organization: A meta-analysis of antecedents, correlates, and consequences. *Journal of Vocational Behavior*, 61(1), 20–52. <https://doi.org/10.1006/jvbe.2001.1842>
- Meyers, L. S., Gamst, G., & Guarino, A. J. (2013). *Applied multivariate research: Design and interpretation*. (Second Edi). Sage Publication.
- Mohd Yusri, I., & Mohd Hazlami, J. (2015). Komunikasi kepemimpinan di sekolah. *7th International Seminar on Regional Education*, 2, 929–938.
- Munian, S., & Hasan, S. (2020). Hubungan Antara Kepimpinan Transformasi Guru Besar dengan Komitmen Kerja dalam kalangan Guru Sekolah Rendah di Daerah Kulim Bandar Baharu, Kedah. *Malaysian Journal of Social Sciences and Humanities (MJSSH)*, 5(6), 136–150. <https://doi.org/10.47405/mjssh.v5i6.434>
- Mustafa, M. Z., Buntat, Y., Omar, M. A., Razzaq, A. R. A., & Ahad, R. (2019). Organizational commitment survey: A confirmatory factorial analysis based on vocational colleges teachers sample. *International Journal of Engineering and Advanced Technology*, 8(5C), 279–288. <https://doi.org/10.35940/ijeat.E1041.0585C19>
- Nik Mustafa, M. A., Mohd Radzi, T., Hazlina, J., Wan Aida Rohana, M. S., & Mohd Nawawi, O. (2015). Principals' Instructional Leadership and Teachers' Commitment in Three Mara Junior Science Colleges (Mjsc) in Pahang, Malaysia. *Procedia - Social and Behavioral Sciences*, 191, 1848–1853. <https://doi.org/10.1016/j.sbspro.2015.04.512>
- Raman, A., & Shariff, S. B. (2017). Relationship Between Technology Leadership, Ict Facility, Competency, Commitments and Teachers Practices on Implementations With Effective Teacher'S Management Tasks in Schools. *Scholedge International Journal of Multidisciplinary & Allied Studies ISSN 2394-336X*, 4(9), 88. <https://doi.org/10.19085/journal.sijmas040901>
- Retnowati, T. H., Mardapi, D., Kartowagiran, B., & Hamdi, S. (2021). A Model of Lecturer Performance Evaluation: Sustainable Lecturer Performance Mapping. *International Journal of Instruction*, 14(2), 83–102.

<https://doi.org/10.29333/iji.2021.1426a>

Robbins, S. P., & Judge, T. A. (2013). *Organizational Behavior* (15th ed.). Pearson.

Roselizam, D., Roslan, A. R., & Amirah Wahidah, A. (2020). Keberkesanan peta pemikiran I-Think dalam meningkatkan kemahiran berfikir aras tinggi (KBAT). *International Social Science and Humanities Jorunal*, 3(1), 64–78. <http://journal.al-qiyam.net/index.php/my1/article/view/49>

Saidin, K., Shafii, S., & Veloo, A. (2020). Novice teachers' strategies to overcome the challenges in teaching and learning. *Elementary Education Online*, 19(2), 69–78. <https://doi.org/10.17051/ilkonline.2020.02.108>

Saragih, I. S., & Suhendro, D. (2020). Pengaruh iklim organisasi sekolah, budaya kerja guru, dan kepuasan kerja terhadap komitmen kerja guru. *Jurnal Akuntabilitas Manajemen Pendidikan*, 8(1), 44–52. <https://doi.org/10.21831/jamp.v8i1.29654>

Setyaningsih, S., & Sunaryo, W. (2021). Optimizing transformational leadership strengthening, self efficacy, and job satisfaction to increase teacher commitment. *International Journal of Instruction*, 14(4), 427–438. <https://doi.org/10.29333/iji.2021.14425a>

Sharina, M. N., Sivapalan, S., Bhattacharyya, E., Hezlina, H., Wan Fatimah, W. A., & Azrai, A. (2014). Organizational communication climate and conflict management: communications management in an oil and gas company. *Procedia - Social and Behavioral Sciences*, 109, 1046–1058. <https://doi.org/10.1016/j.sbspro.2013.12.587>

Slocum, J. W., & Hellriegel, D. (2011). *Principles of Organizational Behavior*. South-Western.

Steers, R. M. (1977). Antecedents and outcomes of organizational commitment. *Administrative Science Quarterly*, 22(1), 46–56. <https://doi.org/10.2307/2391745>

Vandenberghe, C., & Tremblay, M. (2008). The role of pay satisfaction and organizational commitment in turnover intentions: A two-sample study. *Journal of Business and Psychology*, 22(3), 275–286. <https://doi.org/10.1007/s10869-008-9063-3>

Vazirani, N. (2010). Review paper competencies and competency model-A brief overview of its development and application self-concepts. *SIES Journal of Management*, 7(1), 121–131. <https://doi.org/10.1016/j.jvs.2013.03.003>

Yusof, M. R., Mohd faiz, M. Y., & Ibrahim, M. Y. (2019). Measurement model of teaching competency of secondary school teachers in Malaysia. *International Journal of Emerging Technologies and Learning*, 14(20), 157–164. <https://doi.org/10.3991/ijet.v14i20.11465>

Zainuddin, A. (2015). *SEM Made simple a gentle approach to learning structural equation modelling*. MPWS Rich Resources.

Zee, M., & Koomen, H. M. Y. (2016). Teacher self-efficacy and its effects on classroom processes, student academic adjustment, and teacher well-being: A synthesis of 40 years of research. *Review of Educational Research*, 86(4). <https://doi.org/10.3102/0034654315626801>