

Technology acceptance of online instruction for vocational instructors in new normal education

Panita Wannapiroon^{a*}, King Mongkut's University of Technology North Bangkok, Faculty of Technical Education, 518 Pracharat 1 Road, Wongsawang, Bangsue, Bangkok 10800, Thailand <http://orcid.org/0000-0001-8633-5781>

Prachyanun Nilsook^b, King Mongkut's University of Technology North Bangkok, Faculty of Technical Education, 518 Pracharat 1 Road, Wongsawang, Bangsue, Bangkok 10800, Thailand <http://orcid.org/0000-0003-3019-3635>

Jira Jitsupa^{*c}, Suan Dusit University, Faculty of Education, 295 Nakhon Ratchasima Road, Dusit, Bangkok 10300, Thailand <https://orcid.org/0000-0001-6432-6614>

Sakchai Chaeyarak^d Suan Dusit University, Faculty of Education, 295 Nakhon Ratchasima Road, Dusit, Bangkok 10300, Thailand <https://orcid.org/0000-0001-6334-4503>

Suggested Citation:

Wannapiroon, P., Nilsook, P., Jitsupa, J. & Chaeyarak, S. (2021). Technology acceptance of online instruction for vocational instructors in new normal education. *World Journal on Educational Technology: Current Issues*. 13(4), 635-650. <https://doi.org/10.18844/wjet.v13i4.6234>

Received from July 31, 2021; revised from August 15, 2021; accepted from; October 05, 2021;

Selection and peer review under responsibility of Prof. Dr. Servet Bayram, Yeditepe University, Turkey.

©2021 Birlesik Dunya Yenilik Arastirma ve Yayıncılık Merkezi. All rights reserved

Abstract

This research aimed to: develop a model for vocational instructors' acceptance of online instruction after they had arranged online instruction for one year; and investigate the consistency of this model using the empirical evidence gained from 1,818 vocational instructors from five regions in Thailand: the Northern Region, the Northeastern Region, the Central Region, the Eastern Region and Bangkok, and the Southern Region. The research instrument used to collect the data was a questionnaire on the vocational instructors' acceptance of online instruction. The data were analysed using construct validity and the consistency of the causal relationship model. The research findings revealed that social distancing during the COVID-19 pandemic resulted in the vocational instructors' adjusted attitudes towards online instruction for the better. This adjustment directly affected some changes in the instructors' behaviour in physical classroom instruction to online instruction in the following period.

Keywords: online learning, technology acceptance model, vocational education and training

* *ADDRESS OF CORRESPONDENCE: Jira Jitsupa, Faculty of Education, Suan Dusit University, 295 Nakhon Ratchasima Road, Dusit, Bangkok 10300, Thailand

Email Address: jira_jit@dusit.ac.th

1. Introduction

Since the beginning of the Coronavirus or COVID-19 pandemic in 2020, each country has improved how it deals with and controls its spread. (Vladova et al., 2021; Diyana et al., 2020). However, it is still uncertain when the pandemic will end (Kusumadewi et al., 2021) and when people's everyday lives will return to normal. Around the world, citizens' everyday activities such as shopping, work and study are still limited due to a lot of care and social distancing. (Alfadda and Mahdi, 2020). People usually leave their residence just for important matters such as going to work or studying. If possible, they usually avoid going out for trivial matters; they work and study at home or in places which are not crowded, with the focus on activities being done through information technology (IT), the Internet or digital technology. A Global webindex's survey at the beginning of 2021 disclosed that Thais, aged between 16 and 64, spent an average of 9 hours a day using information technology and the Internet, which is the ninth highest level in the world. (Wearesocia, 2021). This shows that the new normal lifestyle has been significantly affected and changed people's lives around the world. Digital technology and online technology are used more, which increases demands for the use of digital technology such as computers, mobile phones, software and applications. This has caused the Internet to become necessary and expand rapidly. (Zarafshani et al., 2020). In particular, face-to-face instruction at all levels of all educational institutes has been completely cancelled and has pivoted to online instruction (Vladova et al., 2021) in which digital technology has been used for instructional management and research design to develop instructional management around the world (Li et al., 2018). Educational institutes, programmes of study and courses have focused more on online instruction through computer network systems, which have expanded quickly (Nawaz and Mohamed, 2020). Preparation for lessons, instruction, teaching activities, evaluation and assessment of learning as well as online instructional models with face-to-face interactive activities between the teacher and the learner, as if they were teaching and learning in the physical classroom, were designed and developed to promote online learning in an effective way. (Zhang et al., 2019). This resulted from the fact that online instructional management could decrease the constraints of time, learning areas and teaching resources, and could widen learners' interests (Zheng and Chen, 2020). With the rapid development of digital technology, educational institutes could effectively apply important policies and tasks with educational reform and online instruction. (He, 2020).

New The COVID-19 pandemic stimulated the use of and accelerated the great popularity and acknowledgement of online instruction or e-learning among teachers and learners, which combines different kinds of instructional media with platforms acting as the mediator managing instructional activities (Sukendro et al., 2020). Online instruction was labelled with different names such as tele-learning, web-based learning or virtual classrooms. No matter what online instruction is called, online instruction still has the same objectives; these are to send knowledge, understanding and skills to learners at all levels, from kindergarten to graduates (Kusumadewi et al., 2021), in all programs and in all fields of study, especially through the use of instruction through lectures and online presentations, whereby teachers and learners stay face-to-face synchronously in the same classroom, similarly to the normal instructional management. The only difference is this classroom is a virtual one, which enables online instruction through digital technology, where teachers and learners are in different physical locations. In this way, learners can learn online, working independently on assignments from their teachers, in an asynchronous way, with no face-to-face interaction between teachers and learners. However, the online instruction in both formats still enables teachers and learners to exchange information and news, deal with instructional difficulties, confer with each other and communicate through different applications other than the ones used via online classrooms. In addition to the COVID-19 pandemic, which rapidly accelerated the full form of online instruction, the advancement and modernity of IT hardware and software, in compact and mobile sizes at reasonable prices, ease of use and teacher-and-learner friendliness, have also promoted and developed online learning. (Mbanga and Mtembu, 2020).

The policy of Thailand 4.0 also aims to reform the economic structure of the country; it aims to develop the economy into one that is driven by innovation and digital technology, as well as internet technology combined with and controlling different devices. These also include artificial intelligence (AI), embedded technology, fintech, the internet of things (IOT), e-marketplace, e-commerce, educational technology as well as the government's economic stimulation with various projects such as the co-payment subsidy programs, 'Khon La Khrueng COVID-19 Relief Program' or 'Rao Chana COVID-19 Relief Program', which need to be joined by participants using digital technology. This has enabled wide use of digital technology at all levels of Thai society; consequently, another community called the digital society has emerged.

Modern digital technology is also an important tool that teachers and learners could apply to other daily activities in addition to their online instruction, such as their work, financial transactions, shopping, communication, entertainment, etc. This causes teachers and learners to consider online instruction as challenging, advanced and up-to-date. In spite of its capability mentioned above, digital technology also has some limitations regarding its application for instruction. These include: the speed of access to Internet technology, its relevant surrounding (Diyana et al., 2021) and its users, teachers and learners. For instance, when teachers and learners attend online instruction while staying at their own locations, there might be times when other factors can interrupt the instruction. For example, some learners need to help their parents take care of their younger siblings or earn their livings.

Online instruction is completely appropriate for lectures, presentations, discussions, self-study and instructional activities delivered mainly through digital technology. In contrast, the instruction which requires learners' real practice with devices, equipment and tools, in laboratories at educational institutes or organizations, requires significant effort on the part of teachers and vocational instructors to adjust their regular teaching methods to those used online, so as to ensure similar outputs for learners. This aims to promote learners' potential and competence, especially vocational learners who are so outstanding with their practical skills that they can work in organizations or run their own business immediately, regarding their own or the organizations' objectives. In addition, since the emergence of COVID-19, vocational instructors have been required to adjust themselves by learning digital technology for their instructional management and to pivot their instruction online immediately (Diyana et al., 2021; Dhawan, 2020). In Thailand, there are currently 913 educational institutes at the vocational level in both public and private sectors. These institutes offer instruction at the vocational certificate level, high vocational certificate level and short course levels, with 1,875,915 students and participants and 22,665 instructors. (Office of the Vocational Education Commission, 2020).

Online instruction for vocational students has been conducted using a complicated process involving various kinds of hardware and software, such as computers, mobile phones, the Internet, applications and instructional tools, including Zoom, Microsoft Teams, Google Classroom, Google Meet and many more devices (Al-Rahmi et al. 2018), and different limitations (ILO-UNESCO-WBG, 2020). At the beginning of 2020, the Office of the Vocational Education Commission, Ministry of Education, urgently prepared and delivered training in synchronous online instruction for Group 1 of 2,233 vocational instructors from vocational institutes in both public and private sectors from five regions of Thailand. (Bureau of Personnel Competency Development, 2020). This aimed to increase knowledge, build understanding, improve skills and enhance online teaching capacity before transferring the developed expertise to the fellow instructors and arranging online instruction for their learners at their own institutes at the vocational level. So far, this has already been conducted for a year. The researchers collected data to study the components of the vocational instructors' acceptance of online instruction using the original Technology Acceptance Model (TAM) (Davis, Bagozzi and Warshaw, 1989); they developed the acceptance model for vocational instructors' online

instruction, which they have been using for one year, and have investigated the consistency of the acceptance model. The study revealed findings which will be discussed later in this article.

Research purpose

The purpose of this research is to develop a model for vocational instructors' acceptance of online instruction having used it for one year and to examine the consistency of this model through the empirical evidence.

Research Hypothesis

The model of the vocational instructors' acceptance of online instruction after its use for one year, according to the developed hypotheses, was consistent with the empirical data, as follows:

No.	Research Hypothesis
H1:	The vocational instructors' perception of ease of online instruction use (PEU) directly affects their perception of online instruction's usefulness (PUS).
H2:	The vocational instructors' perception of ease of online instruction's use (PEU) directly affects their attitude toward the use of online instruction (ATU).
H3:	The vocational instructors' perception of online instruction's usefulness (PUS) directly affects their attitude toward the use of online instruction (ATU).
H4:	The vocational instructors' perception of online instruction's usefulness (PUS) directly affects their behaviour in online instruction (BIN).
H5:	The vocational instructors' attitude toward the use of online instruction (ATU) directly affects their behaviour in online instruction (BIN).
H6:	The vocational instructors' behaviour in online instruction (BIN) directly affects their acceptance of the actual system use of online instruction (AUS).

Research participants

The target participants in this study were the vocational instructors from educational institutes, in both public and private sectors, under the Office of Vocational Education Commission, Ministry of Education, from five regions of Thailand: The Central Region, the Northern Region, the North-eastern Region, the Southern Region, and the Eastern Region and Bangkok. These participants were analysed in terms of ability and selected by the researchers and the committee from the Office of Vocational Education Commission to join the online instruction training in April 2020. In total, 2,233 out of the 2,500 applicants were approved to join the training (Bureau of Personnel Competency Development, 2020). 1,818 vocational instructors, or 81.41%, responded to the questionnaire on vocational instructors' acceptance of online instruction after one-year of use.

2. Methods and Materials

Study Design

The dependent variables comprised of five highly influential variables of the TAM: (Davis, Bogozzi and Warshaw 1989): perceived usefulness (PUS), perceived ease in use (PEU), behavior intention to use (BIN), attitude toward using (ATU), and actual system use (AUS).

TAM Questionnaire

In the study of vocational instructors' acceptance of online instruction after one year of use, the questionnaire used was developed using Google Forms and was divided into two sections: section 1 involved the vocational instructors' details in seven items; section 2 inquired about the vocational instructors' acceptance of online instruction after one-year of use by adapting Davis, Bogozzi and Warshaw's (1989) Questionnaire on Technology Acceptance. Twenty-two questions concerned the perceived usefulness of online instruction, perceived ease of online instruction use, attitude toward the use of online instruction, the vocational instructors' behavior in online instruction and their actual system use of online instruction. The questionnaire was developed on a 5-point Likert rating scale including "extremely", "very", "moderately", "slightly" and "the least/not at all".

Procedure

After the 2,233 vocational instructors from the five regions were trained in online instruction in April 2020, and subsequently arranged online instruction for two terms or one academic year, the researchers contacted all the vocational instructors, using the contact details provided, asking them to complete the questionnaire on the actual system use of their online instruction. In total, 1,818 (81.41%) questionnaires were obtained from the vocational instructors.

Data Analysis

The findings from the analysis of the 1,818 vocational instructors' data were described using the values of mean, percentage and consistency analysis of the model as well as the empirical evidence of the model about the vocational instructors' actual system use of online instruction.

3. Literature Review

Online Learning in Vocational Education and Training

Digital technology has a lot of advantages and good points. One of these is its widespread use throughout all areas of the world, which has really improved educational instruction during the COVID-19 pandemic. This has helped teachers and learners effectively participate in online instruction, according to the goals previously set (Kamal et al., 2020). Various kinds of instruction are possible, such as instruction for individuals and groups or cooperative learning; informal learning such as self-study on interesting issues online or through online networks, either at a fixed time for the whole course or at any convenient and appropriate time; formal instruction with fixed instructional objectives, teaching and learning, participation in learning activities as well as evaluation and assessment to identify learners' achievements. Formal instruction may also consist of the instructor's live lectures and learners' synchronous attendance at the lecture using digital technology such as Zoom, Microsoft Teams, Google Classroom, Google Meet, etc., (Al-Rahmi et al., 2018) anywhere there are internet signals. This is called synchronous instruction. Otherwise, learners attend a class and learn the lesson content through digital technology selected by the teacher, such as Google Classroom, Moodle and YouTube, at the specified time that is convenient for learners. Furthermore, learners can also learn anywhere there are internet signals and they can access the lesson. This does not need to be at the same time as the teacher's time of instruction, which is called asynchronous online instruction (International Baccalaureate, 2020; Dhawan, 2020). In addition, teachers can also prepare for the lesson, teach and arrange learning activities and conduct online evaluation and assessment easily through online resources, available free or for a small charge, creating lesson contents and working together in groups. Sources of still pictures, videos, instructional applications, learning activities and tests, as well as games and simulations, promote knowledge and learning with fun (International Baccalaureate, 2020).

The instruction at vocational level is arranged for learners who are interested in studying and learning with practice in workshops or organisations, to develop knowledge, ability and practical skills, so as to enter the labour market and be ready for work right away, as well as run their own business. In general, vocational instruction employs the face-to-face format in the classroom and practices with real devices, equipment and machinery in workshops and organisations, such as in the areas of building and construction, business and information technology, hospitality and tourism, and mechanics. (Thang Tze Yian, 2017). However, with the recent COVID-19 pandemic, this instructional format was temporarily suspended because of social distancing and was turned into online instruction using digital technology. (Vladova et al. 2021; Chayomchai (2020, The sudden shift of the instructional format has really challenged many vocational instructors who are not yet ready for online instructional management. Online teaching requires a number of factors: the use of various forms of digital technology, vocational instructors having the necessary technological ability, new formats of teaching materials, such as virtual training, authentic and simulated learning, 3D augmented reality and 3D virtual reality (Thang Tze Yian, 2017) as well as experience using digital technology and managing online instruction (Zarafshani et al., 2020). At the same time, these vocational instructors have also been challenged by some factors related to learners; for example, some learners need to study and work together, some have special needs, and some are underprivileged (Thang Tze Yian, 2017).

In Thailand, vocational education is one of the most popular kinds of education; it is considered to be the sixth largest area of Asian-Pacific education (Thang Tze Yian, 2017). The organisation responsible for vocational education is the Office of Vocational Education Commission, Ministry of Education, with 913 educational institutes, both public and private, with 1,875,915 students taking full-time, part-time and short-course programs delivered by 22,665 instructors (Office of the Vocational Education Commission, 2020). However, due to the COVID-19 pandemic, the vocational instruction in Thailand has changed in the same way as most vocational instruction all over the world. The instruction in normal classrooms and workshops has been temporarily suspended and pivoted into online instruction. Unfortunately, many vocational instructors are not yet ready for online instructional management due to their lack of experience in using digital technology and managing online instruction, especially experience in managing online practice. To solve such a short-term problem, in April 2020, the Office of Vocational Education Commission arranged workshop training for 2,233 vocational instructors in Group 1 before the beginning of Term 1, Academic Year 2020 (Bureau of Personnel Competency Development, 2020). This aimed to develop the instructors' knowledge and ability to use digital technology and manage online instruction for their learners. Further training of other groups is planned for a later date. However, vocational instructors from different generations have different kinds of knowledge and skills about digital technology. There are also rapid changes in the advancement of digital technology to meet its users and vocational instructors' requirements, as well as changes in lesson planning, teacher-and-learners' communication, technical help, policy and management of online instruction at each vocational institute (International Baccalaureate 2020) and the basic structure of digital technology (Diyana et al., 2021). So, there is quite a challenge to vocational instructors under the supervision of the Office of Vocational Education Commission, to accept the actual system use of online instruction.

Technology Acceptance Model

Instruction with innovative, new technology could make learning environments interesting and stimulate learners' learning. The current learning environment, due to the development of digital technology, has grown by leaps and bounds, especially during the COVID-19 pandemic. (Ngabiyanto et al., 2021). The acceptance of the actual system use has become an important factor in making different decisions and applying technology for everyday use, as well as being part of convenient

online learning at anywhere which is considered as New Normal instruction (Hubalovsky, Hubalovska and Musilek (2019). Davis (1986) presented the concept of actual system use, which was based on Fishbein and Ajzen’s Theory of Reasonable Action (TRA) (Fishbein and Ajzen, 1975). This concept consists of two factors, attitudes and personal norms, which are applied to and explain the motivation to respond to and accept the actual system use of technology. With this concept, the perceived usefulness and ease of online instruction use affects each person’s attitudes, which can lead to their acceptance and determination of the acceptance of the actual system use of technology (Shore et al., 2018). Later Davis, Bogozzi and Warshaw (1989) presented the concept of TAM with six important factors: external variables, perceived usefulness, perceived ease in use, attitude towards use, behavioural intention to use and actual system use.

The TAM is used to study the acceptance of technology in various ways and is one of the most widely popular models (Zalah, 2018); it has been accepted and applied to the study of new technology acceptance in many for-profit and non-profit organisations and is still accepted and widely used to study the acceptance of new technology. Although TAM has been used for a while, it is still widely used, especially in areas of education (Estriegana, Medina-Merodio, and Barchino 2019) (Abdullah and Ward 2016) such as online learning (Ngabiyanto et al.2021; Kusumadewi et al. 2021; Handoko 2019), classroom response system, blended learning and e-lectures (Sprenger and Schwaninger 2021). It is also popularly used to study technology acceptance in other areas such as mobile virtual reality, medical technology (Vladova et al., 2021), digital learning tools (Thongkoo, Daungcharone and Thanyaphongphat, 2020), graphic design on iPad (Kangwansil and Leelasantitham, 2020), virtual reality technology (Mahalil, Yusof and Ibrahim, 2020), agricultural technology (Zarafshani et al., 2020), sports science (Sukendro et al., 2020), social network (Abraham et al., 2019) (Dumpit and Fernandez, 2017), Big Data (Al-Rahmi et al., 2019), Enterprise Resource Planning (ERP) (Ike Wahyuning et al., 2019), construction industry (Elshafey et al., 2020), blended learning (Tulinayo, Ssentume and Najjuma 2018), gamification (Ab Rahman, Ahmad and Rabaah Hashim, 2018) and information and communication technology (Adu Gyamfi, 2017). Table 1 below shows examples of studies on applications of TAM with different studies of technology acceptance.

Table 1. Examples of studies on applications of TAM

References	TAM				
	Perceived Ease of Use	Perceived Usefulness	Behavior Intention to Use	Attitude Toward Using	Actual System Use
Sprenger and Schwaninger (2021)	✓	✓	✓	-	-
Diyana et al. (2021)	✓	✓	✓	✓	✓
Vladova et al. (2021)	✓	✓	✓	✓	✓
Thongkoo et al. (2020)	✓	✓	✓	✓	✓
Kangwansil and Leelasantitham (2020)	✓	✓	✓	✓	✓
Zarafshani et al. (2020)	✓	✓	✓	-	✓
Mbanga and Mtembu (2020)	✓	✓	✓	✓	✓
Bakri, Sugiarti and Wahyudin (2020)	✓	✓	✓	✓	✓
Sukendro et al. (2020)	✓	✓	✓	✓	✓
Al-Rahmi et al. (2019)	✓	✓	✓	-	-
Tulinayo et al. (2018)	✓	✓	✓	✓	✓
Dumpit and Fernandez (2017)	✓	✓	✓	-	✓

4.Result

The data analysis of 1,818 vocational instructors who responded to the questionnaire revealed the following results. First, most vocational instructors were male (945 respondents: 52%). Second, 731 (40.2%) of vocational instructors were aged between 31 and 40, which was the biggest age group. Third, most vocational instructors, namely 478 (26.3%), were in the position of practitioner level teachers. Fourth, most instructors (1,073 respondents: 59%) held a bachelor's degree. Fifth, most instructors, 467 (25.7%), were trained at the training sites in the Central Region and Bangkok Metropolitan Region. Sixth, 1,105 (60.8%) instructors accepted the innovation and technology of online instruction. Seventh, 1,691 (93%) intended to use online instruction in Academic Year 2021, as shown in the results of the analysis of vocational instructors' data in Table 2.

Table 2. Results of Analysis of Vocational Instructors' Data

Vocational Instructors' Data	Numbers	Percentages
1. Gender		
Male	945	52.0
Female	873	48.0
2. Age Range		
30-20years	385	21.2
40-31years	731	40.2
50-41years	548	30.1
51years up	154	8.5
3. Positions		
Practitioner Level/K1 Teachers	478	26.3
Professional Level/K2 Teachers	373	20.5
Senior Professional Level/K3 Teachers	176	9.7
Expert Level/K4 Teachers	5	0.3
Advisory Level/K5 Teachers	1	0.1
Assistant Teachers	32	1.8
Part-time Teacher	340	18.7
Teachers at Private Institutes	151	8.3
Government Employees (Teachers)	262	14.4
4. Educational Levels		
Non-Degrees	5	0.3
Bachelor Degrees	1,073	59.0
Master Degrees	698	38.4
Doctoral Degrees	42	2.3
5. Training Sites		
The Northern Region	381	21.0
The Northeastern Region	345	19.0
The Central and Bangkok Metropolitan Region	467	25.7
The Eastern Region and Bangkok	326	17.9
The Southern Region	299	16.4
6. Acceptance of Innovation and Technology of Online Instruction		
In a high level	607	33.4
In a moderate level	1,105	60.8
In a low level	106	5.8

Vocational Instructors' Data		Numbers	Percentages
7. Intention with Application of Online Instruction in Academic Year 2021			
Yes		1,691	93.0
No		127	7.0
Total		1,818	100.00

The investigation of the appropriacy and possibility of the model of vocational instructors' acceptance of online instruction, with the presentation of the results from the data analysis of the hypothesis model, was conducted to examine whether the model of vocational instructors' acceptance of online instruction, developed according to the concepts and theories above, showed goodness-of-fit with the empirical evidence. If they were not fit with each other, the model would be modified to be consistent with the empirical evidence, enabling the variances of the standard error of some pairs of observed variables to be correlated and the adjusted model to be fit with the empirical evidence. Then the path analysis of the model correlation is considered, as follows:

The result of the analysis of the model of vocational instructors' acceptance of online instruction was conducted according to the relevant concepts and theories, in terms of goodness-of-fit with the empirical evidence. When the goodness-of-fit index was not found to be consistent with the empirical evidence, the model was modified according to the report of the modification index and the appropriacy and possibility of the concepts, theories and the relevant studies as shown in the model modification. The analysis results revealed the following details. The result of the goodness-of-fit between the hypothesized model and the empirical evidence disclosed that the hypothesized model was not consistent with the empirical evidence, in terms of goodness-of-fit, as follows: 1) $\chi^2 = 3148.181$, $df = 203$, $P\text{-value} = .000$ failed to meet the criteria, due to its value with statistical significance; 2) $\chi^2 / df = 15.508$ failed to meet the criteria because its value was over 00.5; 3) RMSEA = .089 failed to meet the criteria because its value was over 0.08; and 4) GFI = .849 failed to meet the criteria because its value was less than .900. The results of the analysis of the model of vocational instructors' acceptance of online instruction are presented in Figure 1.

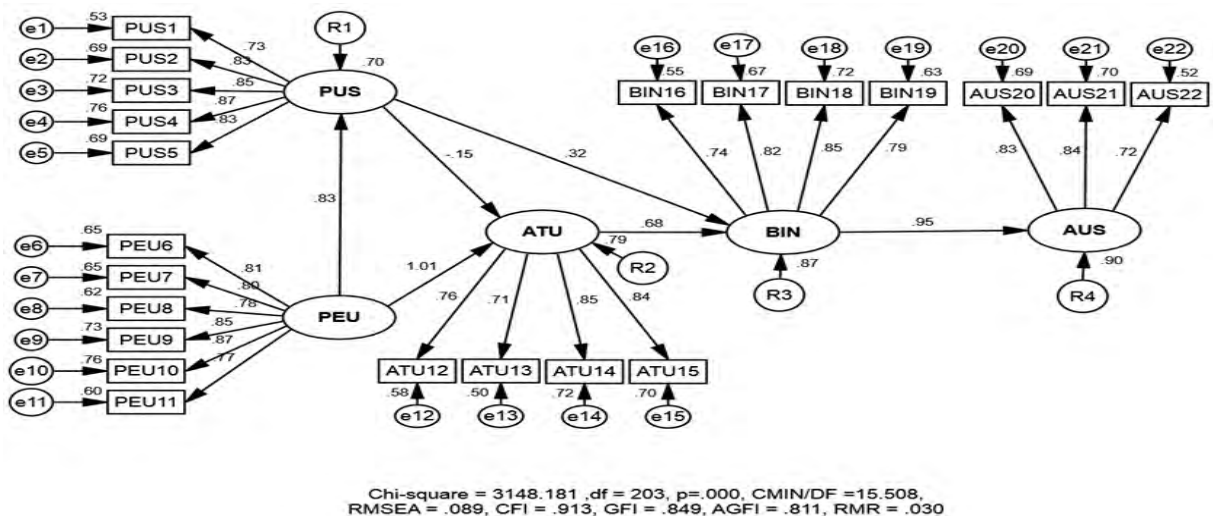

Figure 1. Model of Vocational Instructors' Acceptance of Online Instruction before Modification

The results of the model of vocational instructors' acceptance of online instruction, which was adjusted by cutting lines 10, 11, 18, 19 and 22, revealed that the model better fitted the empirical evidence. The results of the goodness-of-fit of the model with the empirical evidence, after its modification, disclosed that the adjusted model was fit with the empirical evidence, as follows: 1) $\chi^2 = 79.141$, $df = 65$, $P\text{-value} = .112$ satisfied the criteria due to its value of no statistical significance; 2) $\chi^2 / df = 1.217$ satisfied the criteria because its value was lower than 5.00 (Tabachnick and Fidell, 2007); 3) $RMSEA = .011$ satisfied the criteria because its value was lower than 0.08; 4) $RMR = .005$ satisfied the criteria because its value was lower than 0.05; 5) $CFI = .999$ satisfied the criteria because its value was over .900 (Tabachnick and Fidell, 2007); 6) $AGFI = .988$ satisfied the criteria because its value was over .900 (Tabachnick and Fidell, 2007); and 7) $GFI = .995$ satisfied the criteria because its value was over .900. According to the goodness-of-fit index, it was concluded that the structural equation model, which was adjusted, was fit with the empirical evidence; thus, the model estimation was acceptable. The results of the model analysis are presented in Figure 2.

The results of the research hypotheses tests revealed that the model of the vocational instructors' acceptance of online instruction, according to the developed hypotheses, was consistent with the empirical evidence.

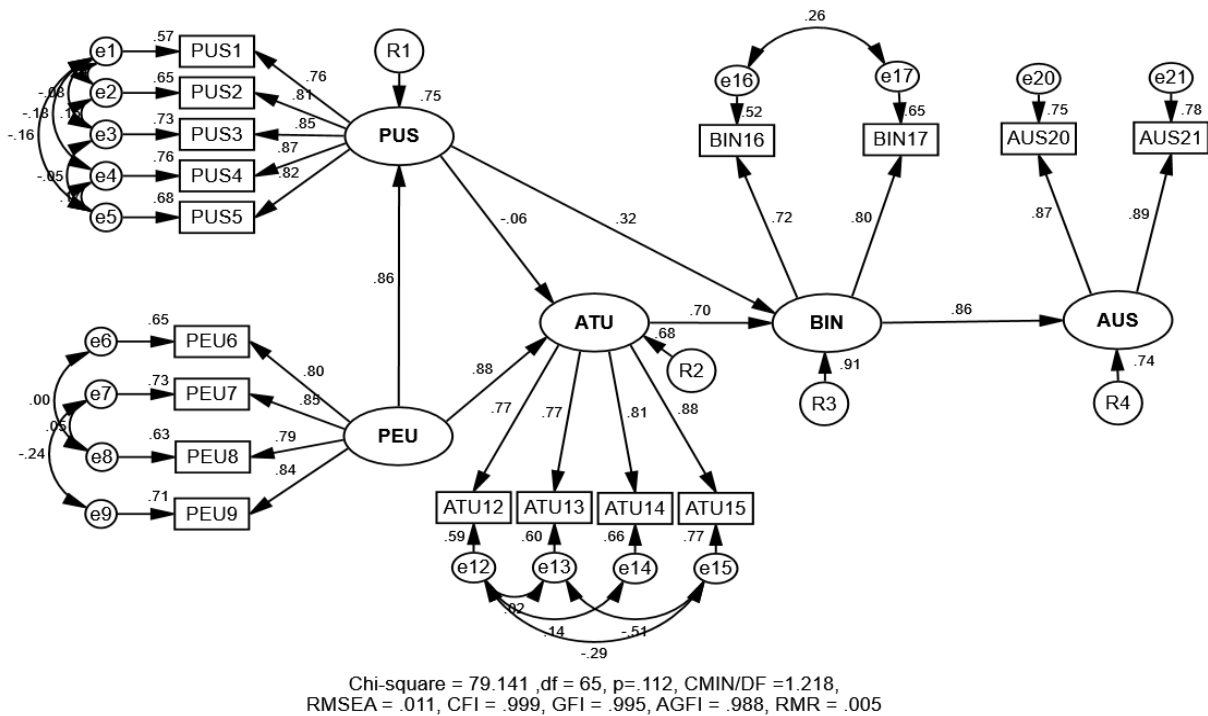

Figure 2. Model of Vocational Instructors' Acceptance Online Instruction after Modification

Table 3. Statistical Values Used to Evaluate Goodness-of-Fit Model of Vocational Instructors' Acceptance of Online Instruction

Type of Measure	Acceptable Level of Fit	Values
Chi-square (χ^2)	< 3.5 to 0	1.217
P-value	> .05	.112
Root-Mean Square Error of Approximation	below 0.10 designates good fit; below	.011

(RMSEA)	0.05 means very good fit.	
Comparative Fit Index (CFI)	equal to or bigger than 0.90.	.999
Goodness of Fit Index (GFI)	equal to or bigger than 0.90.	.995
Adjust Goodness of Fit Index: AGFI	equal to or bigger than 0.90.	.988
Root-Mean Residual (RMR)	Close to 0	.005

The model of the vocational instructors' acceptance of online instruction according to the developed hypotheses, after being used for one year, was consistent with the empirical evidence, as follows:

No.	Research Hypothesis	Test Result
H1:	The vocational instructors' perception of ease in online instruction use directly affects their perception of online instruction usefulness.	Confirmed
H2:	The vocational instructors' perception of ease in online instruction use directly affects their attitude toward the use of online instruction.	Confirmed
H3:	The vocational instructors' perception of online instruction usefulness directly affects their attitude toward the use of online instruction.	Confirmed
H4:	The vocational instructors' perception of online instruction usefulness directly affects their behavior in online instruction.	Confirmed
H5:	The vocational instructors' attitude toward the use of online instruction directly affects their behavior in online instruction.	Confirmed
H6:	The vocational instructors' behavior in online instruction directly affects their acceptance of the actual system use of online instruction.	Confirmed

5. Discussion

TAM M (Davis, Bogozzi and Warshaw, 1989) is used to study the acceptance of various kinds of technology and is one of the most popular models. This study, consequently, used the model to investigate the 1,818 vocational instructors' acceptance of online instruction after using it for one year. These instructors came from five geographical regions in Thailand. This research study focused on two major issues: the development of the model of the vocational instructors' acceptance of online instruction after they had conducted online instruction for one year; the examination of the consistency between the model of the vocational instructors' acceptance of online instruction after one year of use and the empirical evidence.

The research findings discussed the relationships among the study variables, as follows: the relationship between the variables of the developed model of the vocational instructors' acceptance of online instruction varied along with the relationship of the TAM (Sprenger and Schwaninger, 2021), which was developed as the model of the vocational instructors' acceptance of online instruction in this study. This means the vocational instructors' online instruction depended on various factors, which can be classified into the *direct influence*, i.e. the instructors' behavior in online instruction, and the *indirect influences*, i.e. the perception of online-instruction's usefulness, perception of ease in online-instruction use and attitudes toward online-instruction use, which all influenced the acceptance of the actual system use of the vocational instructors' online instruction. All the factors explained how the vocational instructors' online instruction was conducted with the relationships among the variables, as follows:

The perception of the ease of online instruction use directly affects the perception of online instruction's usefulness. When the vocational instructors perceived that online instruction was easy, it affected their study, learning and use of the instruction. Having learned about and used online instruction, the instructors would perceive that online instruction was useful to their students and themselves. This aligns with (Sprenger and Schwaninger, 2021) study on the acceptance of digital

technology for instruction after three month's use, as well as studies (Alfadda and Mahdi, 2021; Kusumadewi et al., 2021; Zarafshani et al., 2020; Rizun and Strzelecki, 2020; Bakri et al., 2020) that have explained that the acceptance of online instruction is easy and directly influences the perception of online instruction's usefulness.

The perception of ease of online instruction use directly affected the attitude toward online instruction use. When the vocational instructors perceived that online instruction was easy, it led to their positive views of online instruction and resulted in their intentions and good attitudes toward online instruction. This aligns with the findings of the studies by Rizun and Strzelecki (2020) and Kusumadewi et al. (2021), which clarified that the perception of ease of online instruction's use directly influenced the instructors' attitude toward online instruction.

The perception of online instruction's usefulness directly influenced the instructors' attitude toward online instruction. When the instructors perceived that online instruction was useful, they had good attitudes towards online instruction, which resulted in their intentions and good attitudes toward online instruction. This aligns with the findings of studies by Rizun and Strzelecki (2020) and Kusumadewi et al. (2021), which explained that the perception of online instruction's usefulness directly influenced the instructors' attitudes toward online instruction.

The perception of online instruction's usefulness directly influenced the instructors' behavior in online instruction. When the instructors perceived that online instruction was useful, it impacted their behavior regarding online instruction and the adjustment of their behavior towards online instruction and its increased use. This aligns with the findings of Sprenger and Schwaninger (2021), who studied the acceptance of digital technology for online instruction after three month's use, as well as the findings of Rizun and Strzelecki (2020), Zarafshani et al. (2020a), Bakri et al. (2020) and Kusumadewi et al. (2021), who explained that the perception of online instruction's usefulness directly influenced the teachers' behavior in online instruction.

The attitude toward online instruction directly influenced the behavior in online instruction. When the instructors had a strong intention and a positive attitude toward online instruction, it resulted in the adjustment of their behavior towards online instruction and the increased use of online instruction. This aligns with the findings of Rizun and Strzelecki (2020) and Kusumadewi et al. (2021), which explained that the attitude toward online instruction directly influenced the behavior in online instruction.

The vocational instructors' behavior in online instruction directly influenced the vocational instructors' acceptance of the actual system use of online instruction. When the vocational instructors conducted online instruction using digital technology, computers, mobile phones and the Internet, it resulted in their familiarity with and their acceptance of online instruction. This caused the instructors to finally accept online instruction. This aligns with the study of Rizun and Strzelecki (2020), Zarafshani et al. (2020a), Bakri et al. (2020) and Kusumadewi et al. (2021), which explained that the vocational instructors' behavior in online instruction affected their acceptance of online instruction.

1. Conclusion

The vocational instructors' acceptance of online instruction might result from their perceptions of the workshop training on online instruction (Bureau of Personnel Competency Development, 2020) and their real practice of conducting online instruction for one year. This showed them that online instruction was easy, convenient, possible to learn and not difficult to use. Further, the instructors also perceived that online instruction was useful to both themselves and their learners, especially during the period of the COVID-19 pandemic, which calls for social distancing. As a result, these vocational instructors adjusted their attitude toward online instruction for the better. This adjusted attitude

directly affected changes in these instructors' behavior from face-to-face classes to online classes and, finally, their acceptance of online instruction for learners in the New Normal period further.

Acknowledgements

The study on Technology Acceptance of Online Instruction for Vocational Instructors in New Normal Education was supported by a research grant from the Bureau of Personnel Competency Development, Office of Vocational Education Commission, Ministry of Education and King Mongkut's University of Technology North Bangkok (KMUTNB).

References

- Ab Rahman, Rafidah, Sabrina Ahmad, and Ummi Rabaah Hashim. 2018. "The Effectiveness of Gamification Technique for Higher Education Students Engagement in Polytechnic Muadzam ShaAb Rahman, R., Ahmad, S., & Rabaah Hashim, U. (n.d.). The Effectiveness of Gamification Technique for Higher Education Students Engagement in Po." *International Journal of Educational Technology in Higher Education* 15 (41) . <https://doi.org/10.1186/s41239-018-0123-0>.
- Abdullah, Fazil, and Rupert Ward. 2016. "Developing a General Extended Technology Acceptance Model for E-Learning (GETAMEL) by Analysing Commonly Used External Factors." *Computers in Human Behavior* 56: 238–56. <https://doi.org/10.1016/j.chb.2015.11.036>.
- Abraham, Shugufta, Bilal Ahmed Mir, Hayato Suhara, Fatin Amirah Mohamed, and Masahiro Sato. 2019. "Structural Equation Modeling and Confirmatory Factor Analysis of Social Media Use and Education." *International Journal of Educational Technology in Higher Education* 16 (1) . <https://doi.org/10.1186/s41239-019-0157-y>.
- Adu Gyamfi, Stephen. 2017. "Information and Communication Technology Acceptance in Education : A Study of Pre-Service Teachers in Ghana." University of Lincoln. <https://search.ebscohost.com/login.aspx?direct=true&db=edsble&AN=edsble.771082&authtype=sso&custid=s5099118&site=eds-live&scope=site&custid=s5099118>.
- Al-Rahmi, Waleed Mugahed, Norma Alias, Mohd Shahizan Othman, Ahmed Ibrahim Alzahrani, Osama Alfarraj, Ali Ali Saged, and Nur Shamsiah Abdul Rahman. 2018. "Use of E-Learning by University Students in Malaysian Higher Educational Institutions: A Case in Universiti Teknologi Malaysia." *IEEE Access* 6 (February): 14268–76. <https://doi.org/10.1109/ACCESS.2018.2802325>.
- Al-Rahmi, Waleed Mugahed, Noraffandy Yahaya, Ahmed A. Aldraiweesh, Uthman Alturki, Mahdi Alamri, Muhammad Sukri Bin Saud, Yusri Bin Kamin, Abdulmajeed A. Aljeraiwi, and Omar Abdulrahman Alhamed. 2019. "Big Data Adoption and Knowledge Management Sharing: An Empirical Investigation on Their Adoption and Sustainability as a Purpose of Education." *IEEE Access* 7 (c) : 47245–58. <https://doi.org/10.1109/ACCESS.2019.2906668n>.
- Alfadda, Hind Abdulaziz, and Hassan Saleh Mahdi. 2021. "Measuring Students' Use of Zoom Application in Language Course Based on the Technology Acceptance Model (TAM) ." *Journal of Psycholinguistic Research*, no. 0123456789. <https://doi.org/10.1007/s10936-020-09752-1>.
- Bakri, Arya, Yatti Sugiarti, and Didin Wahyudin. 2020. "Readiness of Indonesian TVET Teachers in Receiving GIS Technology Using TAM 2." *Invotec* 16 (2): 104–20. <https://doi.org/10.17509/invotec.v16i2.28477>.
- Bureau of Personnel Competency Development. 2020. "Development of Vocational Teachers for Online Teaching and Learning." Office of the Vocational Education Commission : Bangkok, Thailand.

- Wannapiroon, P., Nilsook, P., Jitsupa, J. & Chaiyarak, S. (2021). Technology acceptance of online instruction for vocational instructors in new normal education. *World Journal on Educational Technology: Current Issues*. 13(4), 635-650. <https://doi.org/10.18844/wjet.v13i4.6234>
- Chayomchai, Ampol. 2020. "The Online Technology Acceptance Model of Generation-Z People in Thailand during COVID-19 Crisis." *Management and Marketing* 15 (s1): 496–512. <https://doi.org/10.2478/mmcks-2020-0029>.
- Davis, F. D., Bagozzi, R., P., & Warshaw, P., R. 1989. "User Acceptance of Computer Technology: A Comparison of Two Theoretical Models." *Management Science* 35: 982–1003.
- Davis, F.D. 1986. "A Technology Acceptance Model for Empirically Testing New End-User Information Systems: Theory and Results." Ph.D. Thesis, Massachusetts Institute of Technology, MA, USA.
- Dhawan, Shivangi. 2020. "Online Learning: A Panacea in the Time of COVID-19 Crisis." *Journal of Educational Technology Systems* 49 (1): 5–22. <https://doi.org/10.1177/0047239520934018>.
- Diyana, Nur, Binti Ismail, Mohd Danial, and Afiq Khamar. 2021. "Application of Technology Acceptance Model (Tam) towards Online Learning during Covid-19 Pandemic: Accounting Students Perspective" 24 (1): 13–20.
- Dumpit, Duvince Zhalimar, and Cheryl Joy Fernandez. 2017. "Analysis of the Use of Social Media in Higher Education Institutions (HEIs) Using the Technology Acceptance Model." *International Journal of Educational Technology in Higher Education* 14 (1). <https://doi.org/10.1186/s41239-017-0045-2>.
- Elshafey, Abdalrahman, Chai Chang Saar, Eeydzah Binti Aminudin, Masoud Gheisari, and Abdulrahman Usmani. 2020. "Technology Acceptance Model for Augmented Reality and Building Information Modeling Integration in the Construction Industry." *Journal of Information Technology in Construction* 25 (August 2018): 161–72. <https://doi.org/10.36680/j.itcon.2020.010>.
- Estriegana, Rosa, José-Amelio Medina-Merodio, and Roberto Barchino. 2019. "Student Acceptance of Virtual Laboratory and Practical Work: An Extension of the Technology Acceptance Model." *Computers & Education* 135: 1–14. <https://doi.org/https://doi.org/10.1016/j.compe du.2019.02.010>.
- Fishbein, M., & Ajzen, I. 1975. *Belief, Attitude, Intention, and Behavior: An Introduction to Theory and Research*. Reading, Mass, Don Mills, Ontario: Addison-Wesley Pub. Co.
- Handoko, Bambang Leo. 2019. "Technology Acceptance Model in Higher Education Online Business." *Journal of Entrepreneurship Education* 22 (5).
- He, Yumeng. 2020. "Research on Online Teaching of Music Performance Based on Diversification and Intelligence-Take the Online Music Teaching during the COVID-19 as an Example." *Proceedings - 2020 International Conference on E-Commerce and Internet Technology, ECIT 2020*, 193–96. <https://doi.org/10.1109/ECIT50008.2020.00050>.
- Hubalovsky, S., M. Hubalovska, and M. Musilek. 2019. "Assessment of the Influence of Adaptive E-Learning on Learning Effectiveness of Primary School Pupils." *Computers in Human Behavior* 92 (February 2017): 691–705. <https://doi.org/10.1016/j.chb.2018.05.033>.
- Ike Wahyuning, W., Muharman Lubis, Wahjoe Witjaksono, and Anik Hanifatul Azizah. 2019. "Implementation of Enterprise Resource Planning (ERP) Using Integrated Model of Extended Technology Acceptance Model (TAM) 2: Case Study of PT. Toyota Astra Motor." *2019 7th International Conference on Cyber and IT Service Management, CITSM 2019*. <https://doi.org/10.1109/CITSM47753.2019.8965342>.
- ILO-UNESCO-WBG. 2020. "ILO-UNESCO-WBG Joint Survey on Technical and Vocational Education and Training (TVET) and Skills Development during the Time of COVID-19," no. May: 43.
- International Baccalaureate. 2020. "Online Learning , Teaching and Education Continuity Planning for Schools." *International Baccalaureate Organization*, 1–13. ibo.org.
- Kamal, Ahmad Alif, Norhunaini Mohd Shaipullah, Liyana Truna, Muna Sabri, and Syahrul N. Junaini. 2020. "Transitioning to Online Learning during COVID-19 Pandemic: Case Study of a Pre-University Centre in Malaysia." *International Journal of Advanced Computer Science and Applications* 11 (6) : 217–23.

- Wannapiroon, P., Nilsook, P., Jitsupa, J. & Chaiyarak, S. (2021). Technology acceptance of online instruction for vocational instructors in new normal education. *World Journal on Educational Technology: Current Issues*. 13(4), 635-650. <https://doi.org/10.18844/wjet.v13i4.6234>
- <https://doi.org/10.14569/IJACSA.2020.0110628>.
- Kangwansil, Korawan, and Adisorn Leelasantitham. 2020. "Factors Affecting the Acceptance of Technology Adoption Model in Digital Painting on Tablet of Media Arts Students." *2020 59th Annual Conference of the Society of Instrument and Control Engineers of Japan, SICE 2020*, 614–19.
- Kusumadewi, Aulia Nuraini, Nanda Anthony Lubis, Rhomy Adhy Prastiyo, and Dewi Tamara. 2021. "Technology Acceptance Model (TAM) in the Use of Online Learning Applications During the Covid-19 Pandemic for Parents of Elementary School Students Education , Continues to Increase . This Online Learning for Students is a Follow-up to the Circular of T" 2 (1): 272–92.
- Li, Lin, Yufeng Chen, Zhongjun Li, Dongni Li, Fengxia Li, and Hua Huang. 2018. "Online Virtual Experiment Teaching Platform for Database Technology and Application." *13th International Conference on Computer Science and Education, ICCSE 2018*, no. Iccse: 437–40. <https://doi.org/10.1109/ICCSE.2018.8468849>.
- Mahalil, Imran, Azmi Mohd Yusof, and Nazrita Ibrahim. 2020. "A Literature Review on the Usage of Technology Acceptance Model for Analysing a Virtual Reality' s Cycling Sport Applications with Enhanced Realism Fidelity." *2020 8th International Conference on Information Technology and Multimedia, ICIMU 2020*, 237–42. <https://doi.org/10.1109/ICIMU49871.2020.9243571>.
- Mbanga, N. , and V.N. Mtembu. 2020. "Digital Learning: Perceptions of Lecturers at a Technical Vocational Educational and Training College. " *South African Journal of Higher Education* 34 (4) : 155–73. <https://doi.org/10.20853/34-4-3656>.
- Nawaz, Samsudeen Sabraz, and Rusith Mohamed. 2020. "Acceptance of Mobile Learning by Higher Educational Institutions in Sri Lanka: An UTAUT2 Approach. " *Journal of Critical Reviews* 7 (12) : 1036–49. <https://doi.org/10.31838/jcr.07.12.183>.
- Ngabiyanto, Ahmad Nurkhin, Widiyanto, Iwan Hardi Saputro, and Al Mamnukhin Kholid. 2021. "Teacher' s Intention to Use Online Learning; An Extended Technology Acceptance Model (TAM) Investigation. " *Journal of Physics: Conference Series* 1783 (1). <https://doi.org/10.1088/1742-6596/1783/1/012123>.
- Office of the Vocational Education Commission. 2020. "Annual Report 2019 Office of the Vocational Education Commission Ministry of Education. " <http://bme.vec.go.th/Portals/30/DOWNLOAD/AnnualReport/2562.pdf?ver=2563-05-21-111217-187>.
- Rizun, Mariia, and Artur Strzelecki. 2020. "Students' Acceptance of the Covid-19 Impact on Shifting Higher Education to Distance Learning in Poland." *International Journal of Environmental Research and Public Health* 17 (18): 1–19. <https://doi.org/10.3390/ijerph17186468>.
- Shore, L., Power, V., de Eyto, A., and O'Sullivan, L. 2018. "Technology Acceptance and User-Centred Design of Assistive Exoskeletons for Older Adults: A Commentary." *Robotics* 7 (3).
- Sprenger, David A. , and Adrian Schwaninger. 2021. "Technology Acceptance of Four Digital Learning Technologies (Classroom Response System, Classroom Chat, e-Lectures, and Mobile Virtual Reality) after Three Months' Usage." *International Journal of Educational Technology in Higher Education* 18 (1) . <https://doi.org/10.1186/s41239-021-00243-4>.
- Sukendro, Sukendro, Akhmad Habibi, Khaeruddin Khaeruddin, Boy Indrayana, Syahrudin Syahrudin, Fredrik Alfrets Makadada, and Hikmad Hakim. 2020. "Using an Extended Technology Acceptance Model to Understand Students' Use of e-Learning during Covid-19: Indonesian Sport Science Education Context." *Heliyon* 6 (11): e05410. <https://doi.org/10.1016/j.heliyon.2020.e05410>.
- Tabachnick, B. G., and L. S. Fidell. 2007. *Using Multivariate Statistics*. Boston, MA: Pearson Education Inc.
- Thang Tze Yian, Theresa and Jonghwi Park. 2017. *ICT-Enhanced Innovative Pedagogy in TVET*. Thailand: UNESCO Institute for Statistics. <http://www.unesco.org/open-access/terms-use-ccbysa-en>.

- Wannapiroon, P., Nilsook, P., Jitsupa, J. & Chaiyarak, S. (2021). Technology acceptance of online instruction for vocational instructors in new normal education. *World Journal on Educational Technology: Current Issues*. 13(4), 635-650. <https://doi.org/10.18844/wjet.v13i4.6234>
- Thongkoo, Krittawaya, Kannika Daungcharone, and Jirapipat Thanyaphongphat. 2020. "Students' Acceptance of Digital Learning Tools in Programming Education Course Using Technology Acceptance Model." *2020 Joint International Conference on Digital Arts, Media and Technology with ECTI Northern Section Conference on Electrical, Electronics, Computer and Telecommunications Engineering, ECTI DAMT and NCON 2020*, 377–80. <https://doi.org/10.1109/ECTIDAMTNCN48261.2020.9090771>.
- Tulinayo, Fiona P., Peter Ssentume, and Rovincer Najjuma. 2018. "Digital Technologies in Resource Constrained Higher Institutions of Learning: A Study on Students' Acceptance and Usability." *International Journal of Educational Technolgy in Higher Education* 15 (1). <https://doi.org/10.1186/s41239-018-0117-y>.
- Vladova, Gergana, André Ullrich, Benedict Bender, and Norbert Gronau. 2021. "Students' Acceptance of Technology-Mediated Teaching – How It Was Influenced During the COVID-19 Pandemic in 2020: A Study From Germany." *Frontiers in Psychology* 12 (January): 1–15. <https://doi.org/10.3389/fpsyg.2021.636086>.
- Wearesocia. 2021. "DIGITAL 2021: The Latest Insights Into The 'State Of Digital.'" 2021. <https://wearesocial.com/blog/2021/01/digital-2021-the-latest-insights-into-the-state-of-digital>.
- Zalah, Ibrahim. 2018. "Factors That Influence Saudi Secondary Teachers' Acceptance of E-Learning Technologies." *EDULEARN17 Proceedings*. University of Brighton. <https://doi.org/10.21125/edulearn.2017.2306>.
- Zarafshani, Kiumars, Adel Solaymani, Mike D'Itri, Marilyn M. Helms, and Samaneh Sanjabi. 2020. "Evaluating Technology Acceptance in Agricultural Education in Iran: A Study of Vocational Agriculture Teachers." *Social Sciences & Humanities Open* 2 (1): 100041. <https://doi.org/10.1016/j.ssaho.2020.100041>.
- Zhang, Wenyu, Weiwei Chen, Honghua Zhao, and Rui Wang. 2019. "Research on Teaching Presence Evaluation Indexes of Online Course." *Proceedings - 10th International Conference on Information Technology in Medicine and Education, ITME 2019*, 481–84. <https://doi.org/10.1109/ITME.2019.00113>.
- Zheng, Yanyan, and Ying Chen. 2020. "Construction and Implementation of Blended Teaching Ecology Based on Cloud Class." *Proceedings of 2nd International Conference on Computer Science and Educational Informatization, CSEI 2020*, 292–95. <https://doi.org/10.1109/CSEI50228.2020.9142492>.