

THE  
THORNDIKE  
ARITHMETICS



BOOK TWO

# LIBRARY

## BUREAU OF EDUCATION

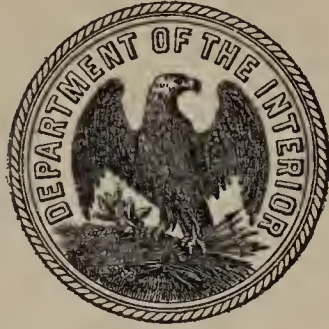

LT

QA103

T5

1917

Bk. 2

6-1132

### Length

12 inches = 1 foot  
 3 feet = 1 yard  
 16½ feet = 3 rods  
 320 rods = 1720 yards  
 5280 feet = 1 mile

### Capacity

1728 cu. in. = 1 cu. ft.  
 27 cu. ft. = 1 cu. yd.  
 128 cu. ft. = 1 bushel

### Dry

2 pints = 1 quart (qt.)  
 8 quarts = 1 peck (pk.)  
 4 pecks = 1 bushel (bu.)

### Liquid Measure

4 gills = 1 pint (pt.)  
 2 pints = 1 quart (qt.)  
 4 quarts = 1 gallon (gal.)

## OTHER MEASURES

A *barrel* of flour contains 196 lb.  
 A *perch* of stone contains 24¾ cu. ft.  
 A *standard gallon* contains 231 cu. in.  
 A *standard bushel* contains 2150.42 cu. in.

52 weeks and 1 day, or 365 days = 1 year  
 Leap years have 366 days  
 Sept., Apr., June, and Nov. have 30 days  
 Feb. has 28 days in regular years, 29 days in leap years  
 All other months have 31 days

### S

#### Area

144 square feet (sq. ft.) = 1 square yard (sq. yd.)  
 30¼ square rods (sq. rd.) = 1 acre (A.)  
 36 square miles (sq. mi.) = 1 square mile (sq. mi.)

#### Weight

16 ounces = 1 pound (lb.)  
 2000 pounds = 1 ton (T.)

#### Weights of 1 Bushel

Wheat = 60 lb.  
 Corn = 56 lb.  
 Oats = 32 lb.  
 Barley = 48 lb.  
 Potatoes = 60 lb.









---

THE THORNDIKE ARITHMETICS

---

BOOK TWO



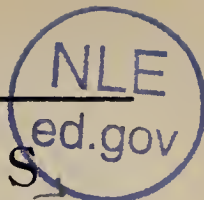

THE THORNDIKE ARITHMETICS

BOOK TWO

By

EDWARD LEE THORNDIKE

Teachers College, Columbia University

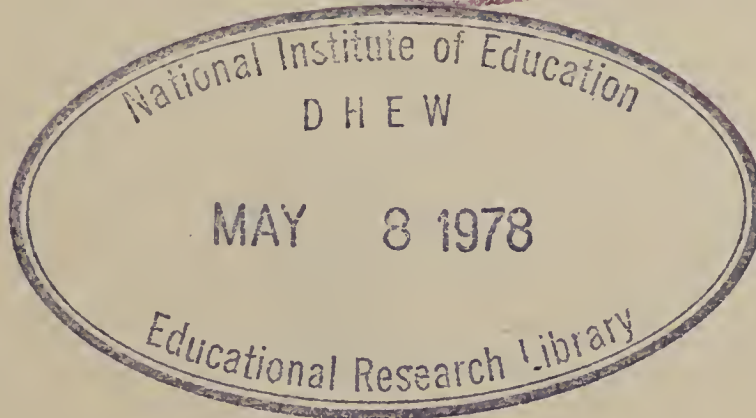

RAND McNALLY & COMPANY

CHICAGO

NEW YORK



Call Number

LT  
QA  
106  
T4  
BK 2  
C.1

Copyright, 1917  
By EDWARD LEE THORNDIKE ✓

Date

5/8/78

78-

845931

LT  
QA103  
T4

Price \$  
54



DEC 10 1917 ✓

© Cl. A 479468

3862449

→ 7011

3-4-18

## PREFACE

THESE books apply the principles discovered by the psychology of learning, by experimental education, and by the observation of successful school practice, to the teaching of arithmetic. Consequently they differ from past practice in the following respects:

Nothing is included merely for mental gymnastics. Training is obtained through content that is of intrinsic value.

The preparation given is not for the verbally described problems of examination papers, but for the actual problems of life. In particular, problems whose answers must be known to frame the problems or whose conditions are fantastic are rigorously excluded.

Reasoning is treated, not as a mythical faculty which may be called on to override or veto habits, but as the coöperation, organization, and management of habits; and the logic of proof is kept distinct from the psychology of thinking.

Interest is secured, not in pictures, athletic records, and the like, but in arithmetic itself and its desirable applications. Interest is not added as a decoration or antidote, but is inter-fused with the learning itself.

Nothing that is desirable for the education of children in quantitative thinking is omitted merely because it is hard; but the irrelevant linguistic difficulties, the unrealizable pretenses at deductive reasoning, and the unorganized computation which have burdened courses in arithmetic are omitted. The demand here is that pupils shall approximate 100 percent efficiency with thinking of which they are capable.

The formation and persistence of useful habits is not left to be a chance result of indiscriminate drill and review. Every habit is formed so as to give the maximum of aid to, and the

minimum of interference with, others. Other things being equal, no habit is formed that must be later broken; two or three habits are not formed where one will do as well; each is formed as nearly as possible in the way in which it is required to function; each is kept alive and healthy by being made to coöperate in the formation of other and higher habits in the arithmetical hierarchy. If a pupil carries through the projects in computing and problem-solving of these three books under competent supervision, he will have abundant practice for the arithmetical insight, knowledge, and skill that the elementary school is expected to provide.

E. L. T.

## NOTES ON BOOK TWO

Parts One and Two are intended for Grades V and VI respectively. Part One provides for mastery of the four operations with such common fractions as the pupils will meet in life, and for ability in the four operations with decimal numbers, in simple cases. Part Two completes the training with decimals, gives mastery of computations with percents and with such denominate numbers as the pupil will meet, and provides experience in simple accounting. The training of Part One in observing and using the relations of numbers is extended and systematized. The applications of arithmetic include simple problems in computing areas, volumes, wages, commissions, discounts, and advances.

The traditional so-called logical arrangement of topics is abandoned in favor of an order that fits the learner's needs, the book being an instrument by which children acquire a rounded, organized, working knowledge of arithmetic, not a display of such knowledge as an adult finally possesses it. The traditional methods of securing ability with fractions, decimals, and percents are also replaced in cases where educational science has found a better way. The resulting selection of topics and methods by expert teachers of arithmetic needs no explanation except perhaps in five particulars. Concerning each of these a brief note is in place.



The pupil learns to add and subtract fractions without any formal treatment of least common multiples, being taught specifically to use fourths, sixths, eighths, twelfths, and sixteenths where each is appropriate, and for other cases to reduce to *any* denominator which is satisfactory. This will be found to save time, prevent ponderous treatment of simple tasks, and in the end be the best introduction to learning what a least common multiple is, if that information is desired.

Division by a fraction is made the occasion (pages 51 to 54) of solid general instruction concerning the reciprocal rule. If any rule is worth teaching in arithmetic it is the rule "To divide by a number is the same as to multiply by the reciprocal of that number." This rule helps to make rational a number of procedures and is often the means of reducing labor greatly in technical and commercial computations.

The equation with a missing number to be supplied is often used in place of verbal forms, such as "24 is what part of 30?" "How much is two thirds of 18?" "\$75 less 10% of itself is how much?" and "What percent of 40 is 32?" These exercises in equation form with missing numbers are harder than routine drills with question and answer, but are more productive of ability, and of ability of a higher type. They also penalize mere *memoriter* acquisition and serve as an ideally clear, brief, and unrestricted form for mental imagery of arithmetical facts and relations. Their value as preparation for the use of formulae in shop arithmetic and for algebra is obvious.

The meanings of decimal numbers are taught directly from an extension of the "thousands, hundreds, tens, ones" series to tenths, hundredths, and so on, as well as from the comparison with  $\frac{1}{10}$ ,  $\frac{1}{100}$ , and  $\frac{1}{1000}$ . The latter is used chiefly to emphasize the smallness of the magnitudes and the commensurability of the two sorts of expressions, and to clarify the general concept of a fraction by experience with fractions with very large denominators. Experience shows that place value, United States money, and railroad distance tables are more useful in explaining decimal numbers than the unfamiliar  $\frac{1}{10}$ s,  $\frac{1}{100}$ s, and  $\frac{1}{1000}$ s.

The placing of the decimal point in division by a decimal number is taught as a consequence of two general rules: "*Divisor*  $\times$  *quotient* must = *dividend*; (*Number of decimal places in the divisor*) + (*number of decimal places in the quotient*) must = (*number of decimal places in the dividend*)."

The special devices by which correctness may be secured are made secondary to full mastery of the general principle and surety in deciding where the decimal point must be in simple cases without the help of any device. The justification for this is the fact that the devices themselves are of little importance, and the common custom of treating them as the essence of the procedure in dividing by a decimal degrades arithmetic to a mere collection of recipes.

In using this book, the best results will be obtained by following its plan closely except for changes authorized by the supervisor in charge of Grades V and VI. Each section contributes something definite toward the growth of arithmetical ability. In many cases the work has as its chief aim the preparation for later acquisitions, or the use together of abilities already acquired separately, or the adaptation of an ability to special difficulties. The abilities and interests which the pupils have, as well as those which they are to acquire, are also considered in arranging the problems and exercises. Consequently, the organization is more subtle than it is in texts in which the pupil learns first to add fractions, then to apply the adding of fractions to problems, then to subtract fractions, then to apply the subtracting of fractions to problems, and so on. The organization in this book, though less obvious, will be found more effective in producing in the learner a steady integration of habits and powers into a total arithmetical ability which will meet life's needs.

It should also be noted that the very frequent tests and reviews in the books are as a rule not mere tests and reviews, but rather progressive steps in the organization of the pupil's ability in his progress toward one hundred percent efficiency in arithmetical thinking.

## CONTENTS\*: PART ONE

### I. ADDITION AND SUBTRACTION OF FRACTIONS: GENERAL THEORY AND TECHNIQUE

SECTIONS	TOPIC OR ACTIVITY	ARITHMETICAL CONTENT	PAGE
1, 2, 3	Summer earnings. Review.	Signs. Meaning and use of fractions and mixed numbers.	1
4 to 8	Common measures.	Denominate numbers. Long division. Meaning of twelfths.	3
9, 10	Whole numbers, fractions, and mixed numbers.	Expressing fractions as whole or mixed numbers and <i>vice versa</i> .	6
11 to 14	Practice in adding and subtracting. Problems.	Review.	7
15, 16	Adding numbers smaller than 1.	Addition of any combination of $\frac{2}{3}$ s, $\frac{4}{3}$ s, and $\frac{8}{3}$ s or of $\frac{2}{3}$ s, $\frac{3}{3}$ s, and $\frac{6}{3}$ s.	9
17, 18, 19	Subtracting numbers smaller than 1.	Subtraction with any combination of $\frac{2}{3}$ s, $\frac{4}{3}$ s, and $\frac{8}{3}$ s.	10
20, 21, 22	Overtime and fines. Keeping account of time.	Subtraction with any combination of $\frac{2}{3}$ s, $\frac{3}{3}$ s, and $\frac{6}{3}$ s. Addition of any combination of $\frac{2}{3}$ s, $\frac{3}{3}$ s, and $\frac{4}{3}$ s.	11
23	Keeping account of time.	Multiplying a fraction by an integer; first steps.	14
24, 25, 26	City lots. Drawing plans.	Review. Dividing, the quotient being less than 1, in very simple cases.	15
27 to 30	Earning. Sharing.	Meaning of $\frac{2}{4}$ s. Quotients less than 1. Expressing one number as a fraction of another. Reductions to higher and lower terms in simple cases.	17

\*The table of contents shows, in one column, the topics and activities in connection with which the learning of arithmetic is secured. In the second column are stated the main elements of the arithmetical content itself. What these are in detail and what applications of them are made to daily life can be discovered by inspection of the text. A still more summary order of topics is shown by the titles of the nine main divisions. It should be understood, however, that the book provides for a continuous growth of arithmetical ability as an integrated whole, and that consequently each main division deals with much more than the one topic.



SECTIONS	TOPIC OR ACTIVITY	ARITHMETICAL CONTENT	PAGE
31 to 36	Understanding fractions.	Reading and writing any common fraction or mixed number. Reducing to higher terms. General theory for adding and subtracting. Meanings of <i>numerator</i> and <i>denominator</i> .	19
37 to 45	Reducing fractions to lower terms. Canceling.	General theory for reducing fractions. Canceling. Rules for divisibility by 2, 3, and 5. Meanings of <i>terms</i> , <i>integer</i> , and <i>prime</i> .	24
46, 47, 48	Cubic inches. Cubical contents. Measuring rainfall.	Cubic inches, cubic feet, and cubic yards. Volume of a rectangular prism.	29

## II. MULTIPLICATION AND DIVISION WITH FRACTIONS AND MIXED NUMBERS

49 to 55	Multiplying with numbers smaller than 1. At the candy counter. Finding exact costs.	Product of an integer and a fraction, general theory and technique. Canceling.	32
56 to 60	Finding a part of a part of a dollar, pound, foot, etc. Objective verifications. Computing areas and volumes.	Product of a fraction or mixed number and a fraction or mixed number.	37
61 to 65	Providing seed. Seed mixtures. Planting fruit trees and small fruits. Camping.	Applications.	41
66 to 69	Floor space of tents. Prices of cartridges.	Dividing when dividend and divisor mean areas or amounts of money or lengths. Expressing quantities in comparable units.	44
70 to 73	Athletic records. A "Fractions Dash." Arithmetic High Jump.	Review of addition, subtraction, and multiplication.	46
74 to 77	Estimating results.	Review of long division. Practice in seeing and using mathematical relations.	49
78 to 79	Dividing by numbers smaller than 1.	Dividing an integer by a fraction. Practice with the reciprocal rule. Finding the reciprocal of a unit fraction.	51
80, 81	Practice in dividing.	Dividing a fraction by an integer. Using the reciprocal of an integer. Meaning of "improper fraction."	53

SECTIONS	TOPIC OR ACTIVITY	ARITHMETICAL CONTENT	PAGE
82 to 85	Practice in dividing.	Using the reciprocal of any fraction. The reciprocal rule generalized and verified.	54
86 to 91	Problem solving.	Review and applications.	56
92, 93	At the meat market.	Combining multiplication by integers with multiplication by a fraction.	60
94 to 98	Vacation trips. Miscellaneous problems. Review.	Problem solving. Review of arithmetical terms and definitions.	61

### III. ADDITION, SUBTRACTION AND MULTIPLICATION WITH DECIMALS. THE FOUR OPERATIONS WITH DENOMINATE NUMBERS

99 to 105	Fractions with large denominators. Measuring distance with a cyclometer.	Meaning of tenths, hundredths, and thousandths, in simple cases. The value of the decimal places to the right of the point as a consequence of decimal notation in general.	65
106 to 110	Reading and writing decimal numbers. A railroad table of distances. Mills.	Meaning and use of decimal numbers. General theory and technique. Preparation for operating with decimals.	70
111 to 114	Adding and subtracting with decimals. A race track.	Adding and subtracting with decimals.	75
115, 116 117	Bicycle trips. Problems about distances.	Using decimals in the multiplicand.	77
118, 119	Provisions for a hunting trip.	Multiplying a decimal number by 10. Review.	80
120	The meaning of very small numbers.	Meaning of ten-thousandths.	82
121, 122 123	Multiplying with decimals. Computing areas.	Decimals in the multiplier and multiplicand. Placing the decimal point in the product.	82
124	Practice with decimal numbers.	Review of addition, subtraction, and multiplication.	84
125	Measuring rainfall.	Dividing a decimal number by an integer in a very simple case.	85
126 to 131	Rainfall problems. Dairy records. Problems.	Use of decimals to four places. Addition, subtraction, multiplication. Division by an integer in simple cases. Preliminary work with aliquot parts.	86

SECTIONS	TOPIC OR ACTIVITY	ARITHMETICAL CONTENT	PAGE
132 to 133	Common measures.	Review of the tables. Reductions.	90
134 to 137	Practical problems. Rations.	Addition, subtraction, and multiplication with denominate numbers.	92
138	Problems.	Applications of addition, subtraction, and multiplication with denominate numbers. Simple cases of division.	95
139, 140	Finding average heights, weights, times, and the like.	Division with denominate numbers. Meaning of <i>perimeter</i> .	96
141	Miscellaneous problems.	Computing volume from dimensions expressed in different units. Review.	97

#### IV. DIVISION WITH DECIMAL NUMBERS: ALIQUOT PARTS: REVIEW

142	Bicycle races. Problems about speed. A "Decimal Race."	Dividing a decimal by an integer.	98
147	Finding exact costs.	Extending the quotient. Annexing zeros to the dividend.	102
148 to 151	Dividing by a decimal.	Rules for placing the decimal point. Checking by " <i>Divisor</i> $\times$ <i>quotient</i> must = <i>dividend</i> ."	103
152	Dairy problems.	Review and applications.	107
153 to 156	Parts of a dollar. Buying and selling.	Aliquot parts.	108
157 to 162	Problems from the farm, business, and travel.	Uses of operations with common and decimal fractions. Review.	112
163 to 169	Practice with common and decimal fractions.	General review.	116



## CONTENTS: PART TWO

### I. COMMON AND DECIMAL FRACTIONS: REVIEW AND ORGANIZATION

SECTIONS	TOPIC OR ACTIVITY	ARITHMETICAL CONTENT	PAGE
1, 2, 3	A vacation trip. An automobile trip. A garden.	Review, especially of decimal fractions.	123
4, 5, 6	The growth of a boy. Growth in arithmetical ability.	Review. Making and interpreting graphs. Ratio: very simple cases.	128
7 to 13	Arithmetical language.	Review, especially of common fractions. Meaning and use of ratios.	132
14 to 18	Very large and very small numbers. Our country's products. Costs.	Complete system of notation. Approximations.	138
19, 20, 21	Dividing by 10 and by 100. Finding costs to a ten-thousandth of a dollar.	Annexing zeros to the dividend.	145
22 to 26	Expressing common fractions as decimal numbers. Expressing decimal numbers as common fractions. Practice with decimals.	Review of multiplication and division. Review of aliquot parts. Expressing mixed numbers as decimals for purposes of division.	148
27, 28	Earning money.	Prefixing zeros in the product. Preparatory experience with " <i>percent of.</i> "	152
29, 30	A multiplication ladder. A division ladder.	Tests of mastery.	154

### II. PROBLEM SOLVING: SIMPLE ACCOUNTS

31, 32	Making a handkerchief box. Using a township map.	Computations and problems connected with a simple working drawing, and a township map.	156
33	The United States.	Comparing very large numbers.	158
34	Drawing to scale.	Drawing to a scale. The relations of numbers.	160
35	Practice.	Extending the span of mental work. Short methods.	161

SECTIONS	TOPIC OR ACTIVITY	ARITHMETICAL CONTENT	PAGE
36, 37, 38	Problem solving.	The technique of thinking with new situations. Practice with miscellaneous problems.	162
39, 40	Graded problems. A problem ladder.	Tests of ability to see and use quantitative relations.	167
41, 42, 43	Keeping accounts. Personal accounts.	The purpose of customary methods. The meaning of <i>receipts, expenditures, balance, cash on hand, paid to new account</i> , and <i>brought forward</i> . Classified accounts and summaries.	169
44, 45	Bills.	The purpose of customary methods. The meaning of <i>extension</i> and <i>footing</i> .	174
46 to 50	Statements and sale slips. Practice with problems from the retail store.	Practice with customary forms and computations. Adding long columns.	176
51	Playing "Bank."	The nature of use of checks. Depositing money and cashing checks. Keeping a bank account.	182
52	Problems from business.	Review.	184

### III. PERCENTAGE

53 to 57	Tenths and hundredths.	<i>Percent</i> means <i>hundredths</i> . <i>Percent of</i> means <i>hundredths times</i> . Practice in translation from decimal to percentile form and <i>vice versa</i> . The use of $\%$ . Computing integral percents.	186
58	Finding percent won, percent lost; percent incorrect, and the like.	Finding what percent $a$ is of $b$ , the result being an integral percent.	191
59, 60	Practice.	Finding a given percent of a quantity when the percent is not integral. Finding what percent $a$ is of $b$ when the result is not an integral percent. Expressing percents as common fractions.	193
61 to 64	Reductions. "A Second-hand Party."	Expressing common fractions as percents. Computing with percents.	195
65, 66	Estimating percents. Practice.	Meaning and use of percents above 100. Review.	198

SECTIONS	TOPIC OR ACTIVITY	ARITHMETICAL CONTENT	PAGE
67, 68	Playing "Commission Merchant." Gains and losses.	Practice with computations of the forms: $b + a\%$ of $b$ , $b - a\%$ of $b$ , $b - a =$ what percent of $a$ , and $b - a =$ what percent of $b$ ; and acquaintance with their uses.	200
69	Finding the percent lost from knowledge of the percent won, and the like.	Adding and subtracting percents.	202
70 to 74	Fixing prices. Discounts and advances. Sharing. Receiving interest on money saved.	Simple business problems in finding a given percent of a quantity, and in finding what percent of a quantity a given quantity is.	202
75 to 79	Keeping account of receipts and expenditures. Making an inventory and appraisal. Keeping account of stock.	Practice with integers, fractions, and percents. Finding the number of which a given number is a certain percent in simple cases.	208
80 to 83	School records. Batting percentages. School examinations.	Review of percentage.	212

#### IV. MEASUREMENTS

84 to 90	Common measures. Comparing gains, rates, and records.	Expressing dimensions in the same unit before computing. Decimals and percents in relation to denominate numbers. Review.	216
91 to 96	Estimating areas. Finding exact areas.	Meanings of <i>perpendicular</i> , <i>parallel</i> , and <i>altitude</i> . Area of a parallelogram. Area of a triangle.	221
97, 98	Finding the area of any surface bounded by straight lines.	Practice in exact measurement. Review. The trapezoid problem as an exercise in intuitive geometry.	228

#### V. PERCENTAGE AND RATIO

99, 100, 101	Comparing quantities.	Practice with the "times as" comparison. Simple uses of ratio and proportion.	230
102, 103	Making mixtures of seeds. Measuring the grade of a road.	Simple cases of proportion.	233

SECTIONS	TOPIC OR ACTIVITY	ARITHMETICAL CONTENT	PAGE
104, 105	Earning, spending, and saving. Selling butter and cheese.	Review. Multiplying by fourths, eighths, and sixths.	236
106, 107	Sharing: of work, a load, hours of watching, and the like.	Proportionate parts in relations to fractions and percents of unity. Practical applications.	238
108, 109, 110	Different ways of obtaining correct results.	Equivalence of certain expressions in common fractions, decimals, and percentages. Addition and subtraction with any common fractions by reduction to decimal fractions. Division of decimal numbers by canceling.	240
111 to 114	Commission. Discounts and advances. Interest.	Review. First steps in computing interest.	243
115, 116, 117	Computing area and volume.	Review.	246
118 to 125	The relations of numbers. Problems.	Review of operations with percents and ratios.	249



# ARITHMETIC

## BOOK TWO, PART ONE

### 1. Summer Earnings

Here is part of the account Fred kept of what he earned, and of how he earned it.

*July 1 to 8.* Errand, 10¢; Errands, 15¢; Water for automobile, 5¢; Errands, 25¢; Water for automobile, 15¢; Egg money, \$1.35.

*July 8 to 15.* Errand, 5¢; Water for automobiles, 25¢; Berries, 60¢; Egg money, \$1.28.

*July 15 to 22.* Water for automobiles, 30¢; Berries, \$1.05; Errands, 15¢; Egg money, \$1.40.

*July 22 to 29.* Errand, 5¢; Berries, \$1.25; Errands, 20¢; Egg money, \$1.20; Chickens sold, \$1.68.

*July 29 to Aug. 5.* Errands, 15¢; Berries, \$1.35; Chickens sold, \$2.00; Egg money, \$1.15.

1. How much money did he earn during the week July 1 to 8?
2. How much did he earn July 8 to 15?
3. July 15 to 22?
4. July 22 to 29?
5. July 29 to Aug. 5?
6. Use your results for examples 1 to 5 and find how much he earned in all five weeks.
7. How much did he earn per week on the average?
8. How much did he earn by doing errands?
9. How much did he earn by bringing water for automobiles?
10. How much did he earn by selling eggs (egg money)?
11. How much did he earn by selling chickens?
12. How much did he earn by picking berries?



*(Without pencil.)*

1. Give as many right answers as you can in 2 minutes:

A.	B.	C.	D.	E.
$19 + 8 =$	$20 \times 9 =$	$\frac{1}{3}$ of 27 =	$7 \times 11 =$	$6 \times 8 =$
$16 - 9 =$	$10 \times 17 =$	$12 - 9 =$	$75 - 25 =$	$36 \div 9 =$
$8 \times 7 =$	$63 \div 7 =$	$\frac{1}{4}$ of 28 =	$10 \times 30 =$	$240 \div 6 =$
$54 \div 6 =$	$3 - 1\frac{1}{2} =$	$\frac{3}{4}$ of 16 =	$66 \div 11 =$	$23 + 9 =$
$7 \times 6 =$	$2\frac{1}{2} + 6\frac{1}{2} =$	$\frac{3}{4}$ of 36 =	$\frac{1}{4} + \frac{1}{4} =$	$\frac{3}{8}$ of 16 =
$72 \div 8 =$	$81 \div 9 =$	$30 \times 12 =$	$\frac{3}{4} + \frac{3}{4} =$	$\frac{1}{2}$ of 50 =
$32 + 9 =$	$35 + 8 =$	$56 \div 8 =$	$100 \div 25 =$	$15\frac{1}{2} - 5\frac{1}{2} =$
$13 - 8 =$	$80 \div 20 =$	$7 \times 50 =$	$\frac{3}{4} - \frac{1}{4} =$	$\frac{2}{3}$ of 36 =

Practice until you can do all five columns in 2 minutes and have every answer right.

## 3.

Write in figures:

- |                            |                             |
|----------------------------|-----------------------------|
| 1. Three hundred thousand. | 6. Three and seven eighths. |
| 2. Six million.            | 7. Four and one fifth.      |
| 3. Three fourths.          | 8. Two and five sixths.     |
| 4. Eight and a half.       | 9. One and a third.         |
| 5. Two thirds.             | 10. Five eighths.           |

Numbers like  $\frac{1}{2}$   $\frac{2}{3}$   $\frac{3}{4}$   $\frac{1}{8}$   $\frac{5}{8}$  are called fractions.

- Write as many different fractions as you can in 3 minutes.
- Count by  $\frac{1}{8}$ s (eighths) to 4 and write the numbers, beginning  $\frac{1}{8}$ ,  $\frac{2}{8}$  or  $\frac{1}{4}$ ,  $\frac{3}{8}$ ,  $\frac{4}{8}$  or  $\frac{1}{2}$ .
- Count by  $\frac{1}{6}$ s (sixths) to 3 and write the numbers, beginning  $\frac{1}{6}$ ,  $\frac{1}{3}$ ,  $\frac{1}{2}$ ,  $\frac{2}{3}$ ,  $\frac{5}{6}$ .
- Find  $\frac{1}{3}$  of 225. Find  $\frac{1}{4}$  of 144. Find  $\frac{1}{5}$  of 175.
- Write the sums:

a.	b.	c.	d.	e.	f.
$28\frac{1}{2}$	$59\frac{1}{4}$	79	$49\frac{1}{4}$	$16\frac{3}{4}$	$75\frac{1}{8}$
$17\frac{1}{2}$	$66\frac{1}{4}$	$38\frac{3}{8}$	60	18	$89\frac{3}{4}$
$35\frac{1}{2}$	$24\frac{1}{2}$	$83\frac{3}{8}$	$72\frac{3}{4}$	$17\frac{3}{4}$	$69\frac{5}{8}$

(Without pencil.)

**1 pound = 16 ounces. 1 lb. = 16 oz.**

16. What part of a pound is 4 ounces? 8 ounces? 2 ounces?
17. How many ounces =  $\frac{3}{8}$  lb.?  $\frac{5}{8}$  lb.?  $\frac{3}{4}$  lb.?  $\frac{7}{8}$  lb.?
18. What part of a pound = 12 oz.? 6 oz.? 10 oz.? 14 oz.?
19. What part of a foot = 3 in.? 6 in.? 9 in.? 4 in.? 8 in.?
20. What part of a yard = 1 ft.? 2 ft.?  $1\frac{1}{2}$  ft.? 12 in.? 9 in.?  
27 in.? 18 in.? 24 in.?
21. How many cents =  $\frac{1}{2}$  dime?  $\frac{1}{4}$  dime?  $\frac{1}{5}$  dime?  $\frac{3}{5}$  dime?
22. How many cents =  $\frac{1}{4}$  dollar?  $\frac{3}{4}$  dollar?  $\frac{2}{5}$  dollar?  $\frac{3}{5}$  dollar?
23. What part of a dime = 5¢?  $2\frac{1}{2}$ ¢?
24. What part of a dollar = 25¢?  $33\frac{1}{3}$ ¢? 75¢? 20¢? 40¢?  
60¢? 80¢?
25. What part of a peck is 1 qt.? 2 qt.? 3 qt.? 4 qt.? 5 qt.?

## 5.

**4 pecks or 32 quarts = 1 bushel.**

**4 pk. or 32 qt. = 1 bu.**

1. How many bushels are there in 225 qt., and how many quarts left over?
2. In 195 qt.? 3. In 416 qt.? 4. In 308 qt.?
5. How many bushels are there in 58 pk., and how many pecks left over?
6. In 50 pk.? 7. In 410 pk.? 8. In 203 pk.?
9. How many pecks are there in 15 bushels and 3 pecks?
10. How many quarts are there in 12 pecks and 5 quarts?
11. How many square inches are there in one square foot?
12. How many square inches are there in 25 square feet?
13. How many square miles are there in 15,275 acres, and how many acres left over? (640 acres = 1 sq. mi.)
14. In 2,875 acres? In 2,120 acres? In 5,000 acres?
15. How many weeks are there in 1 year or 365 days and how many days left over?

4            **1 mile = 5280 ft.    1 square mile = 640 acres.**

16. How many acres are there in  $\frac{1}{4}$  sq. mi.? In  $\frac{1}{8}$  sq. mi.?
17. Is 21,000 ft. more or less than 4 miles? How much more or less?
18. How many miles high is a balloon when it is 26,400 ft. high?
19. A man went without food for 214 hours. How many days was that and how many hours besides?
20. Which is heavier, 25 10-ounce cakes of chocolate or 15 lb. chocolate?
21. How many 125-lb. bags of coal can be filled from 3 tons of coal?

## 6.

*(Do these without pencil if you can.)*

Find the quotients and remainders:

- |                         |                     |                     |                     |                      |                      |
|-------------------------|---------------------|---------------------|---------------------|----------------------|----------------------|
| 1. $12 \overline{)50}$  | $15 \overline{)55}$ | $16 \overline{)40}$ | $17 \overline{)40}$ | $12 \overline{)100}$ | $15 \overline{)100}$ |
| 2. $15 \overline{)85}$  | $12 \overline{)75}$ | $25 \overline{)78}$ | $13 \overline{)45}$ | $16 \overline{)45}$  | $17 \overline{)55}$  |
| 3. $25 \overline{)140}$ | $17 \overline{)30}$ | $15 \overline{)65}$ | $12 \overline{)45}$ | $16 \overline{)50}$  | $12 \overline{)110}$ |
| 4. $13 \overline{)50}$  | $18 \overline{)40}$ | $15 \overline{)95}$ | $14 \overline{)45}$ | $18 \overline{)50}$  | $19 \overline{)60}$  |

## 7. Review

*(Without pencil.)*

1. State the missing numbers. Say as many as you can in 2 minutes.

A.	B.	C.	D.	E.
$\frac{1}{2}$ of 12 =	$\frac{1}{4}$ of 16 =	$\frac{1}{5}$ of 20 =	$\frac{1}{2}$ of 36 =	$\frac{1}{8}$ of 48 =
$\frac{1}{3}$ of 12 =	$\frac{1}{8}$ of 16 =	$\frac{2}{5}$ of 20 =	$\frac{1}{3}$ of 36 =	$\frac{1}{6}$ of 48 =
$\frac{1}{4}$ of 12 =	$\frac{3}{8}$ of 16 =	$\frac{4}{5}$ of 20 =	$\frac{1}{4}$ of 36 =	$\frac{1}{4}$ of 48 =
$\frac{1}{6}$ of 12 =	$\frac{5}{8}$ of 16 =	$\frac{1}{4}$ of 20 =	$\frac{1}{6}$ of 36 =	$\frac{3}{8}$ of 48 =
$\frac{3}{4}$ of 12 =	$\frac{3}{4}$ of 16 =	$\frac{3}{4}$ of 20 =	$\frac{5}{6}$ of 36 =	$\frac{3}{4}$ of 48 =
$\frac{2}{3}$ of 12 =	$\frac{1}{2}$ of 16 =	$\frac{1}{10}$ of 20 =	$\frac{3}{4}$ of 36 =	$\frac{1}{3}$ of 48 =

2. Divide a line 1 foot long into 12 equal parts. How long is  $\frac{1}{12}$  ft.?
3. Divide a line 1 yard long into 12 equal parts. How long is  $\frac{1}{12}$  yd.?
4. Count by 12s to 96, saying, " $\frac{1}{12}$  of 12 is 1,  $\frac{1}{12}$  of 24 is 2,  $\frac{1}{12}$  of 36 is 3," etc.

5. State the quotients:  $16 \overline{)32}$     $16 \overline{)160}$     $16 \overline{)64}$     $16 \overline{)48}$

6. State the missing numbers:

A.	B.	C.	D.
$\frac{1}{2}$ of 32 =	$\frac{1}{3}$ of 36 =	$\frac{1}{8}$ of 48 =	$\frac{5}{8}$ of 16 =
$\frac{1}{4}$ of 32 =	$\frac{1}{6}$ of 36 =	$\frac{1}{16}$ of 48 =	$\frac{5}{16}$ of 16 =
$\frac{1}{8}$ of 32 =	$\frac{1}{12}$ of 36 =	$\frac{2}{16}$ of 48 =	$\frac{7}{12}$ of 24 =
$\frac{1}{16}$ of 32 =	$\frac{5}{12}$ of 36 =	$\frac{5}{12}$ of 48 =	$\frac{7}{8}$ of 24 =
$\frac{3}{16}$ of 32 =	$\frac{7}{12}$ of 36 =	$\frac{3}{8}$ of 48 =	$\frac{7}{8}$ of 32 =
$\frac{5}{16}$ of 32 =	$\frac{1}{12}$ of 24 =	$\frac{3}{8}$ of 16 =	$\frac{7}{16}$ of 32 =
$\frac{9}{16}$ of 32 =	$\frac{1}{12}$ of 48 =	$\frac{3}{12}$ of 24 =	$\frac{7}{16}$ of 48 =

7. Read these lines, supplying the missing numbers:

$$\frac{1}{2} = \frac{\quad}{4} \text{ or } \frac{\quad}{6} \text{ or } \frac{\quad}{8} \text{ or } \frac{\quad}{10} \text{ or } \frac{\quad}{12} \text{ or } \frac{\quad}{16} \quad \frac{1}{3} = \frac{\quad}{6} \text{ or } \frac{\quad}{12} \quad \frac{2}{3} = \frac{\quad}{6} \text{ or } \frac{\quad}{12}$$

$$\frac{1}{4} = \frac{\quad}{8} \text{ or } \frac{\quad}{12} \text{ or } \frac{\quad}{16} \quad \frac{3}{4} = \frac{\quad}{8} \text{ or } \frac{\quad}{12} \text{ or } \frac{\quad}{16}$$

### 8.

1. 1 mile = 1760 yd. or 5280 ft. How many feet are there in  $\frac{1}{12}$  mile?
2. How many feet are there in  $\frac{1}{16}$  mile?
3. How many feet are there in  $\frac{1}{24}$  mile?
4. How many yards are there in  $\frac{1}{12}$  mile? In  $\frac{1}{10}$  mile?
5. 1 square mile (sq. mi.) = 640 acres (A.). How many acres are there in  $\frac{1}{16}$  sq. mi.? 6. In  $\frac{1}{12}$  sq. mi.?
7. How many acres are there in  $\frac{3}{4}$  sq. mi.?
8. How much is  $\frac{1}{8}$  of ten dollars? 9.  $\frac{7}{8}$  of ten dollars?
10. What numbers equal  $\frac{1}{2}$ ? Write as many different ones as you can in a minute.



Numbers like 2, 5, 7, 9, 11, 75, 250 are **whole numbers**.

Numbers like  $\frac{3}{8}$ ,  $\frac{1}{5}$ ,  $\frac{2}{3}$ ,  $\frac{3}{4}$ ,  $1\frac{1}{8}$ ,  $\frac{7}{6}$  are **fractions**.

Numbers like  $4\frac{1}{4}$ ,  $2\frac{7}{8}$ ,  $12\frac{3}{4}$ ,  $1\frac{2}{3}$  are **mixed numbers**.

1. Name the whole numbers or mixed numbers which these fractions equal:

A.	B.	C.	D.	E.
$\frac{5}{4}$	$\frac{4}{3}$	$1\frac{5}{8}$	$\frac{7}{4}$	$1\frac{1}{8}$
$\frac{7}{4}$	$\frac{5}{3}$	$1\frac{6}{8}$	$\frac{6}{3}$	$1\frac{1}{6}$
$\frac{8}{4}$	$\frac{6}{3}$	$\frac{8}{8}$	$1\frac{1}{6}$	$\frac{8}{3}$
$\frac{4}{4}$	$\frac{3}{3}$	$1\frac{1}{6}$	$1\frac{3}{8}$	$\frac{8}{5}$
$\frac{9}{4}$	$\frac{7}{3}$	$1\frac{2}{6}$	$\frac{3}{2}$	$\frac{9}{8}$
$\frac{7}{5}$	$\frac{8}{3}$	$\frac{6}{6}$	$\frac{4}{2}$	$\frac{5}{3}$
$\frac{8}{5}$	$1\frac{1}{8}$	$\frac{7}{6}$	$\frac{7}{5}$	$1\frac{5}{8}$

2. Name the fractions which these mixed numbers equal:

F.	G.	H.	I.	J.	K.
$1\frac{5}{8}$	$1\frac{1}{6}$	$1\frac{1}{4}$	$1\frac{4}{5}$	$1\frac{3}{8}$	$1\frac{1}{4}$
$1\frac{7}{8}$	$1\frac{5}{6}$	$1\frac{3}{4}$	$1\frac{2}{5}$	$1\frac{3}{4}$	$1\frac{2}{3}$
$1\frac{1}{8}$	$1\frac{1}{2}$	$1\frac{2}{3}$	$1\frac{1}{5}$	$1\frac{3}{5}$	$1\frac{2}{5}$
$1\frac{3}{8}$	$2\frac{1}{2}$	$1\frac{1}{3}$	$1\frac{3}{5}$	$1\frac{1}{3}$	$1\frac{1}{8}$

3. State the missing numbers:

$$1 = \frac{\quad}{2} \text{ or } \frac{\quad}{3} \text{ or } \frac{\quad}{4} \text{ or } \frac{\quad}{5} \text{ or } \frac{\quad}{6} \text{ or } \frac{\quad}{8} \text{ or } \frac{\quad}{12} \text{ or } \frac{\quad}{16}$$

### 10.

Find the products of —

- 232 multiplied by 19.
- By 307.
- By  $16\frac{1}{2}$ .
- By  $28\frac{3}{4}$ .
- 608 multiplied by 18.
- By 209.
- By  $5\frac{1}{8}$ .
- By  $34\frac{7}{8}$ .
- Find the cost of 600 acres of land at \$125 per acre.
- Find the cost of  $3\frac{3}{4}$  acres of land at \$620 per acre.
- Find the cost of  $602\frac{3}{4}$  acres of land at \$220 per acre.
- How far will an automobile go in 3 hours at the rate of 18 miles an hour?

## 11. Practice in Adding

7

Say the sums:

6	4	8	4	8	6	4	9	5	5	4	7
4	5	4	3	2	4	5	8	7	4	5	5
3	3	7	5	5	3	3	4	6	3	3	3
5	6	5	9	6	5	6	7	8	5	6	4
<u>9</u>	<u>8</u>	<u>6</u>	<u>5</u>	<u>7</u>	<u>8</u>	<u>7</u>	<u>5</u>	<u>6</u>	<u>6</u>	<u>9</u>	<u>8</u>
2	8	3	5	6	4	6	3	2	4	5	7
5	2	9	2	8	9	2	6	8	7	4	3
3	6	7	6	5	4	8	9	5	5	6	5
9	8	7	8	9	7	3	7	6	4	4	3
<u>7</u>	<u>6</u>	<u>9</u>	<u>5</u>	<u>8</u>	<u>7</u>	<u>9</u>	<u>3</u>	<u>6</u>	<u>9</u>	<u>5</u>	<u>8</u>

Put a slip of paper under the numbers and write the sums. Write them again. Practice until you can add the 24 columns in 4 minutes and have every sum correct.

## 12. Problems

1. Lucy sold  $2\frac{1}{2}$  doz. eggs Monday,  $1\frac{1}{2}$  doz. Tuesday, and  $3\frac{1}{2}$  doz. Wednesday. How many did she sell in all?
2. Nell made candy, using  $4\frac{1}{2}$  lb. sugar,  $\frac{1}{4}$  lb. butter,  $\frac{1}{4}$  lb. chocolate, and  $\frac{3}{4}$  lb. milk. What was the total weight of the materials used?
3. Arthur had five trials at the fifty-yard dash. His times were  $8\frac{1}{2}$  sec.,  $8\frac{4}{5}$  sec.,  $8\frac{2}{5}$  sec., 9 sec., and  $8\frac{3}{5}$  sec. What was his average time?
4. A pail full of milk weighs 18 lb. The empty pail weighs  $2\frac{3}{8}$  lb. How much does the milk weigh?
5. The boys start to walk to Dover,  $13\frac{1}{2}$  miles away. They walk  $8\frac{1}{4}$  miles. How far have they still to go?
6. Mary's exact average was  $87\frac{3}{4}$ . Grace's was  $79\frac{1}{2}$ . How much higher was Mary's average than Grace's?
7. The heights of the five boys on the fifth-grade basketball team are, in inches,  $58\frac{1}{2}$ , 60,  $61\frac{1}{4}$ ,  $62\frac{1}{2}$ , and  $64\frac{3}{4}$ . What is the average height?

1. Add 3 fourths, 3 fourths, and 1 fourth.
2. Add 5 eighths, 7 eighths, and 3 eighths.
3. Read these lines, supplying the missing numbers:  
 $1 = \frac{1}{2}$  or  $\frac{2}{3}$  or  $\frac{3}{4}$  or  $\frac{4}{8}$  or  $\frac{5}{6}$  or  $\frac{6}{8}$  or  $\frac{7}{8}$  or  $\frac{8}{12}$  or  $\frac{9}{16}$  or  $\frac{10}{10}$ .  
 $\frac{1}{2} = \frac{2}{4}$  or  $\frac{3}{6}$  or  $\frac{4}{8}$ .  $\frac{3}{4} = \frac{6}{8}$ .  $\frac{1}{4} = \frac{2}{8}$ .  $\frac{2}{3} = \frac{4}{6}$ .
4. How much must you add to each of these fractions to make 1?

$$\frac{1}{2} \quad \frac{1}{4} \quad \frac{2}{3} \quad \frac{1}{5} \quad \frac{1}{3} \quad \frac{3}{4} \quad \frac{5}{8} \quad \frac{2}{5} \quad \frac{3}{8} \quad \frac{5}{6}$$

5. Add and tell the sums:

$$\begin{array}{lll} \frac{3}{8} + \frac{1}{2} \text{ (or } \frac{4}{8}) = & \frac{7}{8} + \frac{3}{4} \text{ (or } \frac{6}{8}) = & \frac{5}{6} + \frac{1}{2} \text{ (or } \frac{3}{6}) = \\ \frac{3}{4} + \frac{1}{2} \text{ (or } \frac{2}{4}) = & \frac{5}{6} + \frac{1}{3} \text{ (or } \frac{2}{6}) = & \frac{5}{8} + \frac{1}{4} \text{ (or } \frac{2}{8}) = \\ \frac{1}{6} + \frac{1}{2} \text{ (or } \frac{3}{6}) = & \frac{5}{8} + \frac{3}{4} \text{ (or } \frac{6}{8}) = & \frac{1}{4} + \frac{1}{2} \text{ (or } \frac{2}{4}) = \end{array}$$

6. How much must you add to each of these to make  $1\frac{3}{8}$  or  $1\frac{1}{8}$ ?

$$\frac{7}{8} \quad \frac{3}{4} \text{ (or } \frac{6}{8}) \quad \frac{1}{2} \quad \frac{1}{4} \quad \frac{3}{8}$$

7. How much must you add to each of these to make  $1\frac{1}{4}$  or  $\frac{5}{4}$  or  $1\frac{0}{8}$ ?

$$\frac{5}{8} \quad \frac{1}{2} \quad \frac{7}{8} \quad \frac{3}{4} \quad \frac{3}{8}$$

## 14.

1. John ran 100 yards in  $14\frac{4}{5}$  sec. Frank's time was  $12\frac{2}{5}$  sec. How much longer did it take John than Frank?
2. Mrs. Adams bought  $1\frac{1}{2}$  lb. butter Monday,  $1\frac{3}{4}$  lb. Wednesday, and  $2\frac{1}{2}$  lb. Friday. How much did she buy in all?
3. Mrs. Roberts bought  $6\frac{7}{8}$  yd. of cloth. She has  $1\frac{3}{4}$  yd. left. How much has she used?
4. The Adams baby weighs  $10\frac{11}{16}$  lb. It weighed  $8\frac{9}{16}$  lb. a month ago. How much has it gained?

State the sums:

A.	$\frac{1}{2}$	$\frac{1}{8}$	$\frac{1}{4}$	$\frac{1}{3}$	$\frac{2}{3}$	B.	$\frac{4}{5}$	$\frac{3}{4}$	$\frac{5}{8}$	$\frac{3}{8}$	$\frac{1}{6}$
	<u><math>\frac{1}{2}</math></u>	<u><math>\frac{1}{2}</math></u>	<u><math>\frac{1}{2}</math></u>	<u><math>\frac{1}{3}</math></u>	<u><math>\frac{1}{3}</math></u>		<u><math>\frac{2}{5}</math></u>	<u><math>\frac{3}{4}</math></u>	<u><math>\frac{5}{8}</math></u>	<u><math>\frac{3}{8}</math></u>	<u><math>\frac{1}{3}</math></u>
C.	$\frac{3}{8}$	$\frac{2}{3}$	$\frac{3}{4}$	$\frac{4}{5}$	$\frac{1}{2}$	D.	$\frac{1}{4}$	$\frac{5}{8}$	$\frac{5}{8}$	$\frac{3}{8}$	$\frac{1}{3}$
	<u><math>\frac{1}{4}</math></u>	<u><math>\frac{2}{3}</math></u>	<u><math>\frac{1}{2}</math></u>	<u><math>\frac{4}{5}</math></u>	<u><math>\frac{5}{8}</math></u>		<u><math>\frac{5}{8}</math></u>	<u><math>\frac{7}{8}</math></u>	<u><math>\frac{3}{8}</math></u>	<u><math>\frac{3}{4}</math></u>	<u><math>\frac{1}{2}</math></u>

### 16. Addition

Write the sums:

1.  $2\frac{1}{8}$  Think of  $\frac{3}{4}$  as  $\frac{6}{8}$ .  
 $1\frac{3}{4}$  Think of  $\frac{1}{2}$  as  $\frac{4}{8}$ .  
 $4\frac{1}{2}$  Write  $\frac{3}{8}$ . Add 1 to the ones column.
  
2.  $3\frac{1}{3}$  Think of  $\frac{1}{3}$  as  $\frac{2}{6}$ .  
 $2\frac{1}{6}$  Think of  $\frac{1}{2}$  as  $\frac{3}{6}$ .  
 $1\frac{1}{2}$  Do not write  $\frac{6}{6}$ , but add 1 to the ones column.
  
3.  $1\frac{3}{8}$  How do you think of  $\frac{1}{4}$ ?  
 $2\frac{1}{4}$  How do you think of  $\frac{1}{2}$ ?  
 $1\frac{1}{2}$  What fraction do you write?  
 What do you add to the ones column?
  
4.  $1\frac{5}{6}$  How do you think of  $\frac{1}{2}$ ?  
 $2\frac{5}{6}$  How do you think of  $\frac{2}{3}$ ?  
 $2\frac{1}{2}$  What fraction do you write?  
 $3\frac{2}{3}$  What do you add to the ones column?

Write the sums:

5.	6.	7.	8.	9.	10.	11.	12.	13.	14.
$2\frac{1}{2}$	$3\frac{1}{3}$	$1\frac{5}{8}$	$2\frac{1}{2}$	$1\frac{1}{2}$	$1\frac{1}{8}$	$3\frac{1}{3}$	$2\frac{1}{2}$	$2\frac{1}{2}$	$2\frac{3}{4}$
<u><math>2\frac{1}{4}</math></u>	<u><math>1\frac{1}{2}</math></u>	<u><math>4\frac{3}{4}</math></u>	<u><math>1\frac{3}{4}</math></u>	<u><math>3\frac{3}{4}</math></u>	<u><math>3\frac{1}{4}</math></u>	<u><math>2\frac{2}{3}</math></u>	<u><math>1\frac{1}{2}</math></u>	<u><math>1\frac{1}{4}</math></u>	<u><math>3\frac{1}{2}</math></u>
<u><math>1\frac{1}{8}</math></u>	<u><math>1\frac{5}{6}</math></u>	<u><math>2\frac{7}{8}</math></u>	<u><math>3\frac{1}{2}</math></u>	<u><math>1\frac{5}{8}</math></u>	<u><math>5\frac{3}{8}</math></u>	<u><math>7\frac{5}{6}</math></u>	<u><math>4\frac{1}{2}</math></u>	<u><math>3\frac{1}{2}</math></u>	<u><math>4\frac{5}{8}</math></u>



Write the differences:

1.  $6\frac{1}{8}$  Think of  $\frac{1}{2}$  as  $\frac{4}{8}$ .  
 $3\frac{1}{2}$  Increase the  $\frac{1}{8}$  to  $1\frac{1}{8}$  or  $\frac{9}{8}$ .  
           Increase the 3 to 4.
2.  $9\frac{1}{4}$  Think of  $\frac{1}{2}$  as  $\frac{2}{4}$ .  
 $5\frac{1}{2}$  Increase the  $\frac{1}{4}$  to  $1\frac{1}{4}$  or  $\frac{5}{4}$ .  
           Increase the 5 to 6.
3. 9 What must you add to  $\frac{3}{8}$  to make 1?  
 $3\frac{3}{8}$  How do you change the 3?
4. 7 Check your result by adding it to  $2\frac{3}{4}$ .  
 $2\frac{3}{4}$
5.  $8\frac{3}{4}$  How do you think of  $\frac{3}{4}$ ?  
 $2\frac{7}{8}$  Must you increase  $\frac{6}{8}$  to  $\frac{14}{8}$ ?
6.  $7\frac{1}{2}$  How do you think of  $\frac{1}{2}$ ?  
 $4\frac{3}{8}$  Must you increase  $\frac{4}{8}$  to  $\frac{12}{8}$ ?

Write the differences:

7.	8.	9.	10.	11.	12.	13.
$9\frac{1}{2}$	$8\frac{1}{8}$	$6\frac{1}{8}$	$9\frac{5}{8}$	$7\frac{1}{8}$	$8\frac{1}{4}$	$6\frac{1}{8}$
<u><math>4\frac{3}{4}</math></u>	<u><math>5\frac{1}{2}</math></u>	<u><math>1\frac{3}{8}</math></u>	<u><math>3\frac{3}{8}</math></u>	<u><math>4\frac{1}{4}</math></u>	<u><math>5\frac{1}{2}</math></u>	<u><math>2\frac{1}{4}</math></u>

## 18.

1. What must you add to each of these lengths to make 1 inch?  $\frac{1}{2}$  in.  $\frac{1}{4}$  in.  $\frac{1}{8}$  in.  $\frac{3}{4}$  in.  $\frac{3}{8}$  in.  $\frac{2}{3}$  in.
2. What must you add to each of these to make  $1\frac{1}{8}$  or  $\frac{9}{8}$ ?  
 $\frac{3}{8}$   $\frac{5}{8}$   $\frac{7}{8}$   $\frac{3}{4}$   $\frac{1}{2}$   $\frac{1}{4}$
3. What must you add to  $\frac{3}{4}$  to make  $1\frac{5}{8}$ ?
4. How do you think of  $\frac{1}{2}$  when you subtract  $3\frac{1}{2}$  from  $6\frac{7}{8}$ ?
5. How do you think of  $\frac{1}{2}$  when you subtract  $3\frac{1}{2}$  from  $7\frac{3}{4}$ ?
6. How do you think of  $\frac{1}{4}$  when you subtract  $2\frac{1}{4}$  from  $9\frac{5}{8}$ ?
7. How do you think of  $\frac{3}{4}$  when you subtract  $5\frac{3}{4}$  from  $11\frac{3}{8}$ ?

1. Subtract and write the differences. Do not copy the numbers. Just write the number which must be added to the smaller number to give the larger number.

A.	$5\frac{1}{2}$	8	$6\frac{1}{4}$	7	4	3	$9\frac{1}{4}$	$8\frac{1}{8}$
	<u><math>2\frac{1}{2}</math></u>	<u><math>3\frac{3}{4}</math></u>	<u><math>2\frac{1}{2}</math></u>	<u><math>4\frac{1}{8}</math></u>	<u><math>1\frac{1}{4}</math></u>	<u><math>1\frac{3}{8}</math></u>	<u><math>2\frac{3}{4}</math></u>	<u><math>4\frac{1}{2}</math></u>

B.	$15\frac{3}{8}$	17	$14\frac{1}{8}$	$13\frac{3}{4}$	$10\frac{3}{8}$	$18\frac{1}{2}$	$12\frac{1}{8}$	$11\frac{3}{8}$
	<u><math>6\frac{1}{2}</math></u>	<u><math>9\frac{1}{2}</math></u>	<u><math>9\frac{1}{4}</math></u>	<u><math>4\frac{1}{2}</math></u>	<u><math>2\frac{3}{8}</math></u>	<u>9</u>	<u><math>3\frac{3}{8}</math></u>	<u><math>3\frac{3}{8}</math></u>

C.	$12\frac{1}{8}$	$14\frac{1}{2}$	$10\frac{1}{4}$	13	$15\frac{1}{4}$	$11\frac{3}{8}$	$17\frac{1}{4}$	$12\frac{1}{4}$
	<u><math>5\frac{1}{8}</math></u>	<u><math>8\frac{3}{8}</math></u>	<u><math>3\frac{1}{4}</math></u>	<u><math>9\frac{5}{8}</math></u>	<u><math>9\frac{1}{8}</math></u>	<u><math>6\frac{1}{4}</math></u>	<u>9</u>	<u><math>4\frac{5}{8}</math></u>

D.	$13\frac{1}{2}$	$18\frac{5}{8}$	$17\frac{1}{2}$	$11\frac{3}{4}$	12	15	$14\frac{3}{4}$	$16\frac{1}{4}$
	<u><math>5\frac{5}{8}</math></u>	<u><math>9\frac{1}{2}</math></u>	<u><math>7\frac{3}{4}</math></u>	<u><math>5\frac{3}{4}</math></u>	<u><math>6\frac{7}{8}</math></u>	<u><math>7\frac{3}{4}</math></u>	<u><math>7\frac{5}{8}</math></u>	<u><math>8\frac{1}{2}</math></u>

E.	$10\frac{3}{4}$	$12\frac{1}{2}$	$15\frac{1}{2}$	$13\frac{5}{8}$	$10\frac{7}{8}$	14	$16\frac{3}{4}$	$17\frac{1}{8}$
	<u>2</u>	<u><math>7\frac{7}{8}</math></u>	<u><math>8\frac{1}{4}</math></u>	<u><math>8\frac{7}{8}</math></u>	<u><math>4\frac{1}{4}</math></u>	<u><math>6\frac{1}{4}</math></u>	<u><math>9\frac{1}{4}</math></u>	<u><math>8\frac{7}{8}</math></u>

F.	$16\frac{1}{2}$	$11\frac{1}{4}$	$10\frac{7}{8}$	$15\frac{7}{8}$	$10\frac{3}{4}$	$11\frac{7}{8}$	$14\frac{5}{8}$	$13\frac{3}{4}$
	<u><math>7\frac{1}{8}</math></u>	<u><math>4\frac{7}{8}</math></u>	<u><math>6\frac{3}{4}</math></u>	<u><math>5\frac{1}{2}</math></u>	<u><math>5\frac{1}{8}</math></u>	<u><math>7\frac{1}{8}</math></u>	<u><math>5\frac{1}{4}</math></u>	<u><math>7\frac{7}{8}</math></u>

## 20.

1. When you subtract  $4\frac{1}{2}$  from  $6\frac{1}{6}$  or from  $6\frac{5}{6}$  how do you think of  $\frac{1}{2}$ ?

2. When you subtract with  $\frac{1}{3}$ -s and  $\frac{1}{6}$ -s, how do you think of  $\frac{1}{3}$  and  $\frac{2}{3}$ ?

3. Subtract and write the differences:

$10\frac{1}{6}$	$15\frac{1}{2}$	$11\frac{5}{6}$	$14\frac{1}{3}$	$13\frac{1}{6}$	$12\frac{2}{3}$	$16\frac{5}{6}$	$17\frac{1}{2}$
<u><math>2\frac{1}{2}</math></u>	<u><math>6\frac{1}{3}</math></u>	<u><math>3\frac{1}{3}</math></u>	<u><math>8\frac{1}{2}</math></u>	<u><math>5\frac{2}{3}</math></u>	<u><math>4\frac{1}{2}</math></u>	<u><math>9\frac{1}{2}</math></u>	<u><math>8\frac{2}{3}</math></u>

4. Find the differences for exercise 3 without using pencil.

## 21. Overtime and Fines

1. Fred works from 7:30 A.M. till 5 P.M. with  $\frac{1}{2}$  hr. out for dinner. How many hours a day does he work?
2. On Saturdays he begins at 7:30 A.M. and works till noon. How many hours does he work on Saturdays?
3. How many hours does he work per week? (He does not work at all on Sundays.)
4. How much does he receive a week at 20¢ per hour?
5. When he works overtime he receives double pay. How much does he receive for  $1\frac{1}{2}$  hr. overtime work?
6. If he is late to work or if he spoils material by carelessness, a certain amount is subtracted from his pay.

The amounts subtracted from his wages are called fines. Each week he receives a slip like this telling him how much he has worked and how much is subtracted from his pay for fines. How much did he receive for the week of Aug. 1-6?

Aug. 1-6			
F. O'Brien			
	Hours Worked		Fines
	At 20¢	At 40¢	
M.	9	$2\frac{1}{2}$	\$.25
T.	9	$1\frac{1}{2}$	
W.	$8\frac{1}{2}$	$1\frac{1}{2}$	.10
Th.	9	$1\frac{1}{2}$	
F.	9	$1\frac{1}{2}$	
S.	$4\frac{1}{2}$	5	

7. How much did he receive for each of these weeks?

Aug. 8-13			
F. O'Brien			
	Hours Worked		Fines
	At 20¢	At 40¢	
M.	9	$1\frac{1}{2}$	
T.	9	$1\frac{1}{4}$	\$.15
W.	9	$1\frac{1}{4}$	
Th.	9	$1\frac{1}{4}$	.15
F.	9		
S.	$4\frac{1}{2}$		

Aug. 15-20			
F. O'Brien			
	Hours Worked		Fines
	At 20¢	At 40¢	
M.	9		\$.10
T.	9		
W.	9		
Th.	9		
F.	9		.15
S.	$4\frac{1}{2}$	$3\frac{3}{4}$	

	Study	Piano Practice
M.	$\frac{1}{2}$	1
T.	$\frac{3}{4}$	$1\frac{1}{4}$
W.	$\frac{1}{3}$	$\frac{3}{4}$
Th.	$\frac{2}{3}$	$\frac{2}{3}$
F.	$1\frac{1}{4}$	$\frac{3}{4}$
S.	0	1
Totals	<u>        </u>	<u>        </u>

1. Helen decided to keep account of how much she studied outside of school, and how much she practiced on the piano. Here is her account for Dec. 4–9. Find the totals. Helen expresses  $\frac{1}{4}$ s,  $\frac{1}{3}$ s, and  $\frac{1}{2}$ s as  $\frac{1}{12}$ s, so as to make the addition easier.

2. Make a table as Helen does and find the totals for this week:

Mon., Dec. 11. Studied 3:40 to 4:10; practiced 6:45 to 7:30.

Tues., Dec. 12. Studied 5:20 to 5:40; practiced 4:30 to 5:10.

Wed., Dec. 13. Studied 3:15 to 4; practiced 6:45 to 8.

Thurs., Dec. 14. Studied 5:20 to 6; practiced 7 to 7:30.

Fri., Dec. 15. Studied 15 min.; did not practice at all.

Sat., Dec. 16. Did no studying or practicing.

3. On New Year's Day Helen promised that she would study 6 hours a week outside of school and practice 8 hours a week. When Friday night came she had studied  $4\frac{7}{12}$  hr. How much more must she study that week to keep her promise?

4. How many minutes equal  $\frac{1}{12}$  hr.?

5.  $1\frac{5}{12}$  hr. equals 1 hr. and how many minutes?

6. By Friday night Helen had practiced  $7\frac{3}{4}$  hours. How many minutes more must she practice that week to keep her promise?

7. How many hours a week does a girl study if she studies  $\frac{1}{2}$  hr. per day except Sunday?

8. If she studies  $\frac{1}{4}$  hr. per day, except Sunday?

9. If she studies  $\frac{1}{3}$  hr. per day, except Sunday?

10. If she studies  $1\frac{1}{2}$  hour per day, except Sunday?



Supply the missing numbers as shown in the first two lines.

1.  $\frac{3}{4}$  hr. per day for 5 days makes  $\frac{15}{4}$  hr. in all, or  $3\frac{3}{4}$  hr.
2.  $\frac{1}{3}$  hr. per day for 8 days makes  $\frac{8}{3}$  hr. in all, or  $2\frac{2}{3}$  hr.
3.  $\frac{2}{3}$  hr. per day for 2 days makes . . . hr. in all, or . . . hr.
4.  $\frac{2}{3}$  hr. per day for 3 days makes . . . hr. in all, or . . . hr.
5.  $\frac{2}{3}$  hr. per day for 4 days makes . . . hr. in all, or . . . hr.
6.  $\frac{2}{3}$  hr. per day for 5 days makes . . . hr. in all, or . . . hr.
7.  $\frac{2}{3}$  hr. per day for 6 days makes . . . hr. in all, or . . . hr.
8.  $\frac{3}{4}$  hr. per day for 2 days makes . . . hr. in all, or . . . hr.
9.  $\frac{3}{4}$  hr. per day for 3 days makes . . . hr. in all, or . . . hr.
10.  $\frac{3}{4}$  hr. per day for 4 days makes . . . hr. in all, or . . . hr.
11.  $\frac{3}{4}$  hr. per day for 5 days makes . . . hr. in all, or . . . hr.
12.  $\frac{3}{4}$  hr. per day for 6 days makes . . . hr. in all, or . . . hr.
13.  $\frac{1}{3}$  hr. per day for 2 days makes . . . hr. in all, or . . . hr.
14.  $\frac{1}{3}$  hr. per day for 3 days makes . . . hr. in all, or . . . hr.
15.  $\frac{1}{3}$  hr. per day for 4 days makes . . . hr. in all, or . . . hr.
16.  $\frac{1}{3}$  hr. per day for 5 days makes . . . hr. in all, or . . . hr.
17.  $\frac{1}{3}$  hr. per day for 6 days makes . . . hr. in all, or . . . hr.
18.  $\frac{5}{6}$  hr. per day for 2 days makes . . . hr. in all, or . . . hr.
19.  $\frac{5}{6}$  hr. per day for 3 days makes . . . hr. in all, or . . . hr.
20.  $\frac{4}{5}$  hr. per day for 3 days makes . . . hr. in all, or . . . hr.
21.  $\frac{4}{5}$  hr. per day for 4 days makes . . . hr. in all, or . . . hr.
22.  $\frac{1}{4}$  hr. per day for 5 days makes . . . hr. in all, or . . . hr.
23.  $\frac{1}{4}$  hr. per day for 6 days makes . . . hr. in all, or . . . hr.
24.  $\frac{1}{4}$  hr. per day for 10 days makes . . . hr. in all, or . . . hr.
25. Multiply each of these (a) By 3. (b) By 4. (c) By 5:
 

$\frac{2}{3}$	$\frac{3}{4}$	$\frac{3}{5}$	$\frac{1}{2}$	$\frac{1}{4}$	$\frac{5}{8}$	$\frac{3}{8}$	$\frac{5}{6}$	$\frac{1}{6}$
---------------	---------------	---------------	---------------	---------------	---------------	---------------	---------------	---------------

This is a map of part of one block in New York. All the lots are 100 ft. long or, as people say when they talk of house lots, 100 ft. deep. Some are 25 ft. wide, or have 25 feet front. Some are double lots, 50 ft. wide, or have 50 feet front. Some are triple lots, 75 feet wide, or have 75 feet front.

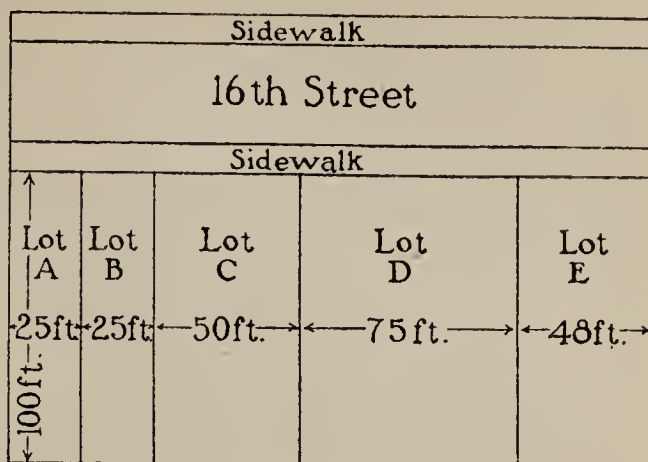

1. How many square feet are there in a lot 25 ft. front by 100 ft. deep?
2. How many square feet are there in a lot 75 ft. front by 100 ft. deep?
3. How many square feet are there in a lot 48 ft. front by 100 ft. deep?
4. The sidewalks on 16th St. are 10 ft. wide. How many square feet are there in a piece of this sidewalk 25 feet long?
5. How many square feet are there in the sidewalk in front of Lot C? In the sidewalk in front of Lot D?
6. 1 inch on this plan stands for or represents 100 ft. What fraction of an inch represents 25 ft.? 75 ft.? 50 ft.? 10 ft.?

## 25.

1. Mr. Lewis owns a piece of land 125 ft. deep with a 700-ft. front. How many lots,  $25 \times 125$  ft. each, will it make?
2. At 15 cents a square foot, how much did the entire piece cost?

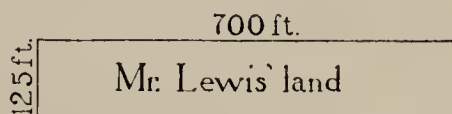

Take a rule marked to show  $\frac{1}{8}$  in.,  $\frac{1}{4}$  in.,  $\frac{3}{8}$  in.,  $\frac{1}{2}$  in., etc. Draw plans as described in exercises 1 to 10. Let 1 inch stand for 80 ft.

1. A rectangular garden 40 by 20 ft.
  2. A house lot 30 ft. front by 120 ft. deep.
  3. A house lot 40 ft. front and deep enough to contain 3600 sq. ft. in all.
  4. A square garden plot 50 ft. on each side.
  5. A garden 60 feet long and wide enough to contain 10 plots each 20 by 15 ft.
  6. A baseball diamond 30 yards square.
  7. A tennis court 36 by 78 ft. with 7 feet of space extra on each side and 11 feet of space extra on each end, as shown in the picture.
- Tennis Court
8. How many square feet are required for the tennis court itself? How many square feet more are required to give 11 ft. space at the ends and 7 ft. space at each side?
  9. A football field 100 yards long and 160 feet wide.
  10. A room 40 ft. by 30 ft.
  11. What fraction or mixed number represents each of these when 1 represents 80?  
10    40    20    30    50    60    70    90    120    100
  12. What part of 12 is 3, one fourth or one third?
  13. What part of 12 is 8, two thirds or three fourths?
  14. What part of 16 is 10? Does  $\frac{10}{16}$  equal  $\frac{5}{8}$  or  $\frac{6}{8}$  or  $\frac{7}{8}$ ?
  15. What part of 20 is 12? Does  $\frac{12}{20}$  equal  $\frac{2}{5}$  or  $\frac{3}{5}$  or  $\frac{4}{5}$ ?
  16. What part of 20 is 15?
  17. What part of 24 is 15?



Mr. Stern wished to have the dandelions and plantains and yellow dock dug out from his lawns and fields and paths. So he paid the boys  $\frac{1}{12}\text{¢}$  (one twelfth of a cent) for every yellow dock,  $\frac{1}{16}\text{¢}$  for every dandelion, and  $\frac{1}{24}\text{¢}$  (one twenty-fourth of a cent) for every plantain they dug out. How many cents did each boy earn?

1. Will dug 276 yellow docks.    2. Fred dug 512 dandelions.
3. Dick dug 552 plantains.    4. Joe dug 336 dandelions.
5. George dug 156 yellow docks and 312 plantains.
6. John dug 192 yellow docks and 208 dandelions.
7. Henry dug 368 dandelions and 192 plantains.
8. Paul dug 48 yellow docks, 96 dandelions, and 216 plantains.
9. James dug 72 yellow docks, 80 dandelions, and 168 plantains.

## 28.

1. Will and Fred bought a bag of 30 marbles for 5¢. Will paid 3¢. Fred paid 2¢. How many of the marbles should Will have? How many should Fred have?
2. John and Dick bought a bag of 64 marbles for 8¢. John paid 3¢. Dick paid 5¢. How many of the marbles should John have? How many should Dick have?
3. Paul and George bought a collection of 36 glass marbles for 12¢. Paul paid 7¢. George paid 5¢. How should they divide the marbles?
4. Alice and Nell bought a dozen picture postcards for 15¢. Alice paid 10¢. Nell paid 5¢. How should they divide the postcards?
5. Mary and Ruth bought a big bunch of roses for 16¢. Mary paid 7¢. Ruth paid 9¢. There were 64 roses. How should they be divided between Mary and Ruth?



1. Read and supply the missing numbers:

A.

$$16 = \frac{1}{2} \text{ of } 32$$

$$8 = \frac{1}{2} \text{ of } 32$$

$$4 = \frac{1}{2} \text{ of } 32$$

$$2 = \frac{1}{2} \text{ of } 32$$

B.

$$8 = \frac{1}{3} \text{ of } 24$$

$$4 = \frac{1}{3} \text{ of } 24$$

$$2 = \frac{1}{3} \text{ of } 24$$

$$4 = \frac{1}{3} \text{ of } 48$$

C.

$$2 = \frac{1}{2} \text{ of } \dots$$

$$2 = \frac{1}{3} \text{ of } \dots$$

$$2 = \frac{1}{4} \text{ of } \dots$$

$$2 = \frac{1}{16} \text{ of } \dots$$

D.

$$2 = \frac{1}{2} \text{ of } 48$$

$$4 = \frac{1}{2} \text{ of } 48$$

$$6 = \frac{1}{2} \text{ of } 48$$

$$8 = \frac{1}{2} \text{ of } 48$$

- Tell what part of 36 each of these numbers is: 18, 9, 3, 12, 4, 6.
- Tell what part of 30 each of these numbers is: 15, 10, 5, 3, 6.
- Tell what part of 60 each of these numbers is: 5, 6, 10, 15, 30, 20.

## 30.

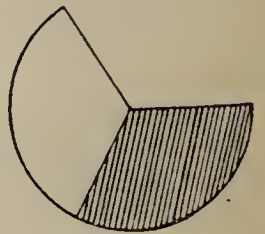
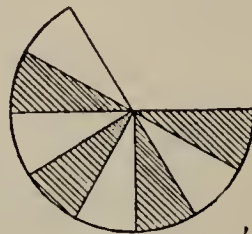
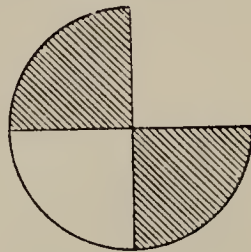
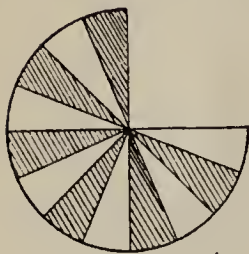

- Which two pictures show that  $\frac{3}{4} = \frac{12}{16}$ ?
- Which two pictures show that  $\frac{2}{3} = \frac{8}{12}$ ?
- Draw a picture to show that  $\frac{1}{2} = \frac{8}{16}$ .
- Draw a picture to show that  $\frac{1}{4} = \frac{4}{16}$ .
- Draw a picture to show that  $\frac{3}{4} = \frac{6}{8}$ .
- Draw a picture to show that  $\frac{1}{2} = \frac{6}{12}$ .
- Read each of these. Tell whether it is less than  $\frac{1}{2}$  lb., equal to  $\frac{1}{2}$  lb., or more than  $\frac{1}{2}$  lb.:  
 4 oz.    12 oz.    8 oz.     $\frac{1}{4}$  lb.     $\frac{2}{4}$  lb.     $\frac{7}{8}$  lb.  
 $\frac{4}{8}$  lb.     $\frac{3}{16}$  lb.     $\frac{11}{16}$  lb.     $\frac{8}{16}$  lb.
- Read each of these and tell whether it is less than  $\frac{1}{2}$  ft., equal to  $\frac{1}{2}$  ft., or more than  $\frac{1}{2}$  ft.:  
 5 in.     $\frac{5}{12}$  ft.    6 in.     $\frac{6}{12}$  ft.    7 in.     $\frac{7}{12}$  ft.

9. Read, supplying the missing numbers:

$$\frac{1}{2} = \frac{\quad}{4} \text{ or } \frac{\quad}{6} \text{ or } \frac{\quad}{8} \text{ or } \frac{\quad}{10} \text{ or } \frac{\quad}{12} \text{ or } \frac{\quad}{16} \quad \frac{1}{4} = \frac{\quad}{8} \text{ or } \frac{\quad}{16}$$

$$8 \text{ oz.} = \frac{\quad}{16} \text{ lb. or } \frac{\quad}{8} \text{ lb. or } \frac{\quad}{4} \text{ lb. or } \frac{\quad}{2} \text{ lb.}$$

$$12 \text{ oz.} = \frac{\quad}{16} \text{ lb. or } \frac{\quad}{8} \text{ lb. or } \frac{\quad}{4} \text{ lb.}$$

$$4 \text{ oz.} = \frac{\quad}{16} \text{ lb. or } \frac{\quad}{8} \text{ or } \frac{\quad}{4} \text{ lb.} \quad 6 \text{ oz.} = \frac{\quad}{16} \text{ lb. or } \frac{\quad}{8} \text{ lb.} \quad \frac{3}{8} = \frac{\quad}{16}.$$

$$8 \text{ in.} = \frac{\quad}{12} \text{ ft. or } \frac{\quad}{6} \text{ ft. or } \frac{\quad}{3} \text{ ft.} \quad 9 \text{ in.} = \frac{\quad}{12} \text{ ft. or } \frac{\quad}{4} \text{ ft.}$$

$$9 \text{ in.} = \frac{\quad}{12} \text{ yd. or } \frac{\quad}{4} \text{ yd.} \quad 18 \text{ in.} = \frac{\quad}{12} \text{ yd. or } \frac{\quad}{2} \text{ yd. or } \frac{\quad}{4} \text{ yd.}$$

10. How many minutes equal  $\frac{1}{2}$  hr.?  $\frac{1}{6}$  hr.?  $\frac{1}{12}$  hr.?  $\frac{3}{4}$  hr.?

11. What part of an hour equals 30 min.? 20 min.? 15 min.? 5 min.? 10 min.? 45 min.? 50 min.?

12. Read, supplying the missing numbers:

$$20 \text{ min.} = \frac{\quad}{12} \text{ hr. or } \frac{\quad}{6} \text{ hr. or } \frac{\quad}{3} \text{ hr.} \quad 15 \text{ min.} = \frac{\quad}{12} \text{ hr. or } \frac{\quad}{4} \text{ hr.}$$

$$10 \text{ min.} = \frac{\quad}{12} \text{ hr. or } \frac{\quad}{6} \text{ hr.} \quad 45 \text{ min.} = \frac{\quad}{12} \text{ hr. or } \frac{\quad}{4} \text{ hr.}$$

$$30 \text{ min.} = \frac{\quad}{12} \text{ hr. or } \frac{\quad}{4} \text{ hr. or } \frac{\quad}{2} \text{ hr.}$$

### 31. Reading and Writing Fractions and Mixed Numbers

We read —

$\frac{3}{2}$  three halves

$\frac{5}{3}$  five thirds

$\frac{7}{9}$  seven ninths

$1\frac{1}{24}$  eleven twenty-fourths

$5\frac{7}{8}$  five and seven eighths

We write —

eleven eighths  $\frac{11}{8}$  or  $1\frac{3}{8}$

six and one fifth  $6\frac{1}{5}$  or  $6\frac{1}{5}$

two thirty-sixths  $\frac{2}{36}$  or  $\frac{1}{18}$

one fiftieth  $\frac{1}{50}$  or  $\frac{1}{50}$

nine twentieths  $\frac{9}{20}$  or  $\frac{9}{20}$

1. Read these fractions and mixed numbers:

$$21\frac{5}{8} \quad 1\frac{1}{2} \quad 1\frac{1}{4} \quad 1\frac{1}{12} \quad 2\frac{3}{16} \quad 4\frac{1}{3} \quad \frac{5}{2} \quad 1\frac{5}{8}$$

$$\frac{7}{24} \quad 1\frac{3}{50} \quad 1\frac{7}{36} \quad 2\frac{8}{12} \quad \frac{7}{10} \quad 2\frac{3}{10} \quad \frac{4}{7} \quad 2\frac{3}{24}$$

2. Write in numbers:

a. Five sixteenths. b. Five thirds. c. Eleven twentieths.

d. Ten eighths. e. One and five twelfths. f. Seventeen

thirty-sixths. g. Three and five twenty-fourths.

h. Four and one seventh. i. Nine and seven twentieths.

j. Eight and two ninths.

In  $\frac{3}{4}$  or  $\frac{1}{5}$  or  $\frac{7}{8}$  the 3 or 1 or 7 is called the *numerator*;  
the 4 or 5 or 8 is called the *denominator*.

1. Name five numerators found on this page.
2. Name five denominators found on this page.
3. Which do you read first in reading a fraction, the numerator or the denominator?
4. Does the denominator tell the *size* of the parts or the *number* of parts?
5. Name some fractions in which five is used as the numerator.
6. Name some fractions in which five is used as the denominator.
7. Multiply the numerator and denominator in  $\frac{3}{4}$  yd. each by 2. Is the result less than  $\frac{3}{4}$  yd. or equal to  $\frac{3}{4}$  yd. or more than  $\frac{3}{4}$  yd.?
8. Multiply the numerator and denominator in  $\frac{1}{2}$  lb. each by 8. Compare the result with  $\frac{1}{2}$  lb.

## 33.

If the numerator and denominator of a fraction are multiplied by the same number, the amount or value of the fraction is the same as before.

1. Multiply both numerator and denominator of each of these fractions by 2 and tell the result. Say, " $\frac{1}{2} = \frac{2}{4}$ ,  $\frac{1}{3} = \frac{2}{6}$ ," etc.

$$\frac{1}{2} = \quad \frac{1}{3} = \quad \frac{1}{4} = \quad \frac{1}{5} = \quad \frac{1}{6} = \quad \frac{1}{8} =$$

$$\frac{2}{3} = \quad \frac{3}{4} = \quad \frac{2}{5} = \quad \frac{3}{5} = \quad \frac{4}{5} = \quad \frac{5}{6} =$$

$$\frac{3}{8} = \quad \frac{5}{8} = \quad \frac{7}{8} =$$

2. Multiply both numerator and denominator of each of these fractions by 3 and tell the result. Say, " $\frac{1}{2} = \frac{3}{6}$ ,  $\frac{1}{4} = \frac{3}{12}$ ," etc.

$$\frac{1}{2} \quad \frac{1}{4} \quad \frac{3}{4} \quad \frac{1}{8} \quad \frac{3}{8} \quad \frac{5}{8}$$

3. Multiply both numerator and denominator of each of these fractions by 4 and tell the result. Say, " $\frac{1}{2} = \frac{4}{8}$ ,  $\frac{1}{3} = \frac{4}{12}$ ," etc.

$$\frac{1}{2} \quad \frac{1}{3} \quad \frac{2}{3} \quad \frac{1}{4} \quad \frac{3}{4} \quad \frac{1}{6} \quad \frac{5}{6}$$

4. State the missing numerators:

A.	B.	C.
$\frac{1}{2} = \frac{\quad}{12}$ Or $\frac{\quad}{8}$ Or $\frac{\quad}{16}$ Or $\frac{\quad}{10}$	$\frac{4}{5} = \frac{\quad}{10}$	$\frac{3}{8} = \frac{\quad}{24}$ Or $\frac{\quad}{16}$
$\frac{3}{4} = \frac{\quad}{12}$ Or $\frac{\quad}{8}$ Or $\frac{\quad}{16}$ Or $\frac{\quad}{24}$	$\frac{5}{6} = \frac{\quad}{12}$ Or $\frac{\quad}{24}$	$\frac{3}{5} = \frac{\quad}{10}$
$\frac{2}{3} = \frac{\quad}{15}$ Or $\frac{\quad}{12}$ Or $\frac{\quad}{24}$	$\frac{1}{4} = \frac{\quad}{8}$ Or $\frac{\quad}{16}$ Or $\frac{\quad}{12}$	$\frac{1}{6} = \frac{\quad}{24}$ Or $\frac{\quad}{12}$
$\frac{5}{8} = \frac{\quad}{16}$ Or $\frac{\quad}{24}$	$\frac{1}{3} = \frac{\quad}{12}$ Or $\frac{\quad}{6}$ Or $\frac{\quad}{24}$	

To reduce or change a fraction to higher terms, multiply both the numerator and denominator by 2 or 3 or 4 or 5 or some larger number.

5. Change these fractions to  $\frac{\quad}{16}$ s:

$$\frac{1}{2} \quad \frac{3}{8} \quad \frac{1}{4} \quad \frac{3}{4} \quad \frac{5}{8}$$

6. Change these fractions to  $\frac{\quad}{24}$ s:

$$\frac{1}{8} \quad \frac{1}{4} \quad \frac{3}{8} \quad \frac{3}{4} \quad \frac{1}{2} \quad \frac{5}{8} \quad \frac{5}{6} \quad \frac{1}{6} \quad \frac{1}{3} \quad \frac{2}{3} \quad \frac{7}{8}$$

### 34.

When you add fractions, express them as fractions having the same denominator.

Add	Write or think	Add	Write or think
$3\frac{1}{2}$	$\frac{6}{12}$	$2\frac{9}{16}$	$\frac{9}{16}$
$2\frac{1}{3}$	$\frac{4}{12}$	$1\frac{1}{2}$	$\frac{8}{16}$
$4\frac{1}{4}$	$\frac{3}{12}$	$2\frac{3}{4}$	$1\frac{2}{16}$

Find the sums. Express the fractions in each column as fractions having the same denominator. Then add.

1.	2.	3.	4.	5.	6.	7.	8.
$1\frac{3}{4}$	$1\frac{1}{8}$	$2\frac{1}{3}$	$3\frac{1}{4}$	$3\frac{1}{4}$	$1\frac{1}{4}$	$1\frac{1}{6}$	$2\frac{1}{4}$
$2\frac{1}{2}$	$3\frac{1}{4}$	$2\frac{3}{4}$	$3\frac{1}{8}$	$2\frac{3}{8}$	$1\frac{1}{6}$	$1\frac{1}{4}$	$2\frac{1}{6}$
$1\frac{2}{3}$	$2\frac{1}{16}$	$2\frac{1}{2}$	$3\frac{3}{16}$	$2\frac{1}{16}$	$4\frac{2}{3}$	$1\frac{2}{3}$	$2\frac{1}{2}$



When you subtract with fractions, express them as fractions having the same denominator.

1. How shall you express  $\frac{1}{2}$  when you subtract  $\frac{1}{2}$  from  $\frac{4}{6}$  or  $\frac{2}{3}$  or  $\frac{7}{6}$  or  $\frac{5}{6}$ ? 2. When you subtract  $\frac{1}{2}$  from  $\frac{5}{4}$  or  $\frac{3}{4}$ ?
3. From  $\frac{7}{8}$  or  $\frac{1}{8}$  or  $\frac{5}{8}$ ? 4. From  $\frac{9}{16}$  or  $\frac{15}{16}$ ?
5. How shall you express  $\frac{1}{3}$  when you subtract it from  $\frac{1}{2}$ ?
6. When you subtract it from  $\frac{5}{4}$  or  $\frac{3}{4}$ ? 7. From  $\frac{7}{6}$  or  $\frac{5}{6}$ ?
8. From  $\frac{5}{12}$  or  $\frac{7}{12}$  or  $\frac{11}{12}$ ?

Find the differences. Express the fractions as  $\frac{6}{8}$ s or  $\frac{8}{8}$ s or  $\frac{12}{12}$ s or  $\frac{16}{16}$ s when you need to:

9.	10.	11.	12.	13.	14.	15.	16.
$5\frac{1}{3}$	$4\frac{9}{16}$	$8\frac{1}{2}$	$6\frac{7}{12}$	$3\frac{11}{12}$	$7\frac{3}{4}$	$9\frac{1}{4}$	$5\frac{1}{16}$
<u><math>2\frac{1}{4}</math></u>	<u><math>1\frac{1}{2}</math></u>	<u><math>3\frac{1}{8}</math></u>	<u><math>3\frac{1}{4}</math></u>	<u><math>1\frac{2}{3}</math></u>	<u><math>4\frac{1}{6}</math></u>	<u><math>5\frac{1}{3}</math></u>	<u><math>2\frac{3}{4}</math></u>
17.	18.	19.	20.	21.	22.	23.	24.
$4\frac{11}{16}$	$7\frac{7}{12}$	$3\frac{1}{2}$	$8\frac{7}{16}$	$6\frac{2}{3}$	$8\frac{5}{16}$	$6\frac{3}{4}$	$5\frac{9}{16}$
<u><math>1\frac{1}{4}</math></u>	<u><math>2\frac{1}{3}</math></u>	<u><math>1\frac{5}{12}</math></u>	<u><math>3\frac{3}{4}</math></u>	<u><math>4\frac{3}{4}</math></u>	<u><math>5\frac{1}{2}</math></u>	<u><math>2\frac{2}{3}</math></u>	<u><math>4\frac{1}{4}</math></u>

## 36.

The boys were disputing about the distance from their school to Golden Bridge.



Find the missing numbers or answers.

1. John said, "I think it is  $2\frac{1}{4}$  mi. from the school to the 4 corners, and  $3\frac{2}{3}$  mi. from the 4 corners to the stone church, and  $1\frac{1}{2}$  mi. from the stone church to Golden Bridge. That would make . . . . mi. from the school to the bridge."

2. Dick said, "I think it is  $2\frac{1}{3}$  mi. from the school to the 4 corners, and  $3\frac{3}{4}$  mi. from the 4 corners to the stone church, and  $1\frac{1}{3}$  mi. from the stone church to Golden Bridge. That would make . . . . mi. from the school to the bridge."
3. Will said, "I think it is  $2\frac{3}{4}$  mi. from the school to the 4 corners, and 4 mi. from there to the church, and then  $1\frac{5}{6}$  mi. from the church to the bridge. That would be . . . . mi. in all."

*When you add or subtract with  $\frac{1}{4}$ s and  $\frac{1}{6}$ s, express them as  $\frac{1}{12}$ s or as  $\frac{1}{24}$ s. It is a little quicker to express them as twelfths.*

4. Joe guessed  $2\frac{1}{6}$ ,  $3\frac{1}{4}$ , and  $1\frac{2}{3}$ , making . . . for the total distance.
5. Henry guessed  $2\frac{1}{8}$ ,  $3\frac{1}{3}$ , and  $1\frac{1}{4}$ , making . . . for the total distance.

*When you add or subtract with  $\frac{1}{3}$ s and  $\frac{1}{8}$ s, express them as  $\frac{1}{24}$ s.*

6. Henry's father measured the distance for them and found that it was almost exactly  $7\frac{1}{8}$  miles. How much too large was John's estimate of  $7\frac{5}{12}$  miles?

$7\frac{5}{12}$      $\frac{10}{24}$     *When you add or subtract with  $\frac{1}{12}$ s and  $\frac{1}{8}$ s,*  
 $7\frac{1}{8}$      $\frac{3}{24}$     *express them as  $\frac{1}{48}$ s or  $\frac{1}{24}$ s or  $\frac{1}{72}$ s or  $\frac{1}{96}$ s.*

*It is quicker to express them as  $\frac{1}{24}$ s.*

7. How much too large was Will's estimate of  $8\frac{7}{12}$  miles?
8. Was Joe's estimate too large or too small?

Find the sums:

9.	10.	11.	12.	13.	14.	15.
$21\frac{1}{3}$	$16\frac{5}{8}$	$31\frac{1}{8}$	$42\frac{5}{12}$	$22\frac{5}{8}$	$15\frac{1}{8}$	$21\frac{2}{3}$
<u><math>17\frac{3}{4}</math></u>	<u><math>12\frac{7}{8}</math></u>	<u><math>23\frac{2}{3}</math></u>	<u><math>13\frac{3}{8}</math></u>	<u><math>15\frac{2}{3}</math></u>	<u><math>16\frac{1}{4}</math></u>	<u><math>14\frac{3}{4}</math></u>
16.	17.	18.	19.	20.	21.	22.
$2\frac{1}{4}$	$4\frac{1}{6}$	$5\frac{3}{8}$	$2\frac{5}{8}$	$3\frac{1}{6}$	$4\frac{5}{6}$	$2\frac{3}{8}$
<u><math>3\frac{2}{3}</math></u>	<u><math>1\frac{1}{4}</math></u>	<u><math>6\frac{1}{3}</math></u>	<u><math>7\frac{1}{2}</math></u>	<u><math>3\frac{1}{12}</math></u>	<u><math>4\frac{1}{2}</math></u>	<u><math>5\frac{3}{4}</math></u>

## 37. Reducing Fractions to Lowest Terms

1. Divide the numerator and the denominator of each of these fractions by 2, and state the result. Say " $\frac{6}{8} = \frac{3}{4}$ ,  $\frac{10}{12} = \frac{5}{6}$ ," etc.

$$\frac{6}{8} \quad \frac{10}{12} \quad \frac{10}{16} \quad \frac{4}{6} \quad \frac{6}{16} \quad \frac{8}{10} \quad \frac{2}{12} \quad \frac{2}{16}$$

2. Divide the numerator and the denominator of each of these fractions by 4 and state the result:

$$\frac{12}{16} \quad \frac{8}{12} \quad \frac{4}{8} \quad \frac{4}{24} \quad \frac{4}{12} \quad \frac{20}{24} \quad \frac{4}{16}$$

3. Divide the numerator and the denominator of each of these fractions by 3 and state the result:

$$\frac{9}{12} \quad \frac{3}{6} \quad \frac{3}{12} \quad \frac{6}{24} \quad \frac{6}{12} \quad \frac{3}{24} \quad \frac{9}{24}$$

To reduce a fraction to lower terms means to divide both the numerator and the denominator by 2 or 3 or 4 or some larger number. A fraction is in its lowest terms when the numerator and denominator cannot both be divided by 2 or 3 or 4 or 5 or some larger whole number, without a remainder.

*Numbers like  $\frac{1}{8}$ ,  $\frac{3}{8}$ ,  $\frac{5}{8}$ ,  $\frac{3}{4}$ ,  $1\frac{1}{2}$ ,  $1\frac{5}{12}$ ,  $3\frac{7}{16}$ , and  $2\frac{4}{5}$  are in lowest terms.*

*Numbers like  $\frac{4}{8}$ ,  $\frac{6}{8}$ ,  $\frac{2}{8}$ ,  $\frac{2}{4}$ ,  $\frac{4}{4}$ ,  $1\frac{8}{12}$ ,  $3\frac{12}{16}$ , and  $2\frac{5}{5}$  are not in lowest terms.*

## 38.

Look at each of these fractions. If it is in lowest terms, say, "It is in lowest terms." If it is not in lowest terms, express it in lowest terms.

a.	b.	c.	d.	e.	f.	g.	h.	i.	j.
$\frac{1}{2}$	$\frac{1}{3}$	$\frac{1}{4}$	$\frac{1}{6}$	$\frac{1}{8}$	$\frac{1}{12}$	$\frac{8}{12}$	$\frac{1}{16}$	$\frac{8}{16}$	$\frac{2}{24}$
$\frac{2}{2}$	$\frac{2}{3}$	$\frac{2}{4}$	$\frac{2}{6}$	$\frac{2}{8}$	$\frac{2}{12}$	$\frac{9}{12}$	$\frac{2}{16}$	$\frac{9}{16}$	$\frac{3}{24}$
$1\frac{1}{2}$	$\frac{3}{3}$	$\frac{3}{4}$	$\frac{3}{6}$	$\frac{3}{8}$	$\frac{3}{12}$	$\frac{10}{12}$	$\frac{3}{16}$	$\frac{10}{16}$	$\frac{4}{24}$
$\frac{4}{2}$	$1\frac{1}{3}$	$\frac{4}{4}$	$\frac{4}{6}$	$\frac{4}{8}$	$\frac{4}{12}$	$\frac{11}{12}$	$\frac{4}{16}$	$\frac{11}{16}$	$\frac{5}{24}$
	$1\frac{2}{3}$	$1\frac{1}{4}$	$\frac{5}{6}$	$\frac{5}{8}$	$\frac{5}{12}$	$\frac{12}{12}$	$\frac{5}{16}$	$\frac{12}{16}$	$\frac{6}{24}$
	2	$1\frac{2}{4}$	$\frac{6}{6}$	$\frac{6}{8}$	$\frac{6}{12}$	$\frac{8}{8}$	$\frac{6}{16}$	$\frac{13}{16}$	$\frac{7}{24}$

The numerator and denominator are called the *terms* of a fraction.

1. Multiply both terms of  $\frac{3}{4}$  by 2, and give the result.
2. Divide both terms of  $\frac{1^2}{1^6}$  by 4, and give the result.
3. Which term of a fraction tells whether the fraction means halves or thirds or quarters or fifths, etc.?
4. Which term of a fraction tells how many halves or thirds or quarters or fifths or sixths, etc., are used?
5. Find which of these fractions is equal to  $\frac{6}{8}$  and tell whether it is in higher terms than  $\frac{6}{8}$  or in lower terms:

$$\frac{2}{3} \quad \frac{3}{5} \quad \frac{3}{8} \quad \frac{3}{2} \quad \frac{3}{4} \quad \frac{9}{16} \quad \frac{7}{12} \quad \frac{8}{12} \quad \frac{10}{12} \quad \frac{1}{2}$$

6. Which of them is equal to  $\frac{4}{8}$ ? 7. Is it in higher or lower terms than  $\frac{4}{8}$ ?
8. Which two of them are equal to  $\frac{4}{6}$ ? 9. Which of the two is in lower terms than  $\frac{4}{6}$ ? Which is in higher terms than  $\frac{4}{6}$ ?
10. Write as many fractions as you can in two minutes which are in lowest terms.
11. Which term of each of these fractions is divisible by 2 (can be divided by 2 without any remainder)?

$$\frac{3}{4} \quad \frac{9}{16} \quad \frac{15}{16}$$

12. Which term is divisible by 3 (can be divided by 3 without any remainder)?
13. In which of these fractions can both terms be divided by 4 without any remainder?

$$\frac{9}{6} \quad \frac{9}{16} \quad \frac{12}{16} \quad \frac{8}{12} \quad \frac{15}{16} \quad \frac{6}{9} \quad \frac{4}{5} \quad \frac{9}{12} \quad \frac{15}{24}$$

14. In which of these fractions can both terms be divided by 3 without remainders?



## 40. Canceling

When you divide both terms of a fraction by the same number you may **cancel** the two terms like this:  $\frac{\cancel{9}}{\cancel{24}}$

and write the two new terms like this:  $\frac{\cancel{9}^3}{\cancel{24}_8} = \frac{3}{8}$

Sometimes you may cancel the two new terms again like this:

$$\frac{\cancel{12}^2}{\cancel{42}_7} = \frac{2}{7}$$

Copy these fractions. Express each one in lowest terms by canceling and writing the new terms. Cancel several times, if you need to do so.

- |                 |                 |                 |                 |                 |                 |                 |                 |
|-----------------|-----------------|-----------------|-----------------|-----------------|-----------------|-----------------|-----------------|
| 1.              | 2.              | 3.              | 4.              | 5.              | 6.              | 7.              | 8.              |
| $\frac{9}{12}$  | $\frac{8}{12}$  | $\frac{15}{25}$ | $\frac{10}{30}$ | $\frac{16}{32}$ | $\frac{18}{24}$ | $\frac{12}{27}$ | $\frac{21}{24}$ |
| 9.              | 10.             | 11.             | 12.             | 13.             | 14.             | 15.             | 16.             |
| $\frac{20}{25}$ | $\frac{12}{32}$ | $\frac{10}{12}$ | $\frac{24}{40}$ | $\frac{21}{36}$ | $\frac{16}{36}$ | $\frac{28}{40}$ | $\frac{6}{16}$  |

## 41.

1. How many garden plots of 48 sq. ft. each can be made from a piece of land 32 ft. wide and 90 ft. long?

Find the answer by canceling, like this:

$$\frac{\cancel{32}^2 \times \cancel{90}^3}{\cancel{48}_1} = \frac{2 \times 30}{1} \text{ or } 60$$

Check the answer by multiplying 32 by 90 and dividing the product by 48.

2. How many plots of 36 sq. ft. each can be made from a piece of land 32 ft. wide and 120 ft. long?
3. How many chicken yards of 108 sq. ft. each can be made from a piece of land 162 ft. by 72 ft.?
4. It requires a piece of cloth 27 in.  $\times$  36 in. to make an apron. How many aprons can be made from a piece 54 in.  $\times$  108 in.?

Write  $\frac{54 \times 108}{27 \times 36}$  and cancel. Write 6 for  $\frac{6}{1}$

Cancel and write the results:

5.	6.	7.	8.	9.
$\frac{7 \times 32}{8 \times 14}$	$\frac{9 \times 48}{12 \times 18}$	$\frac{10 \times 54}{6 \times 45}$	$\frac{9 \times 80}{16 \times 3}$	$\frac{6 \times 24}{4 \times 9}$

#### 42.

The houses on one side of a street are given the odd numbers, 1, 3, 5, 7, etc. The houses on the other side of the street are given the even numbers, 2, 4, 6, 8, 10, etc.

1. Read these lines, saying the right words or numbers where the dots are:

Any... number can be divided by 2 without a remainder.

Any number ending in 2, 4, 6, 8, or 0 can be divided by ... without a remainder.

Look at these numbers: 5 10 15 20 25 30 35 40

They end in either...or...

Each of them can be divided by...without a remainder.

2. Can any number whose last digit is 5 or 0 be divided by 5 without remainder?
3. Think what this rule means:

If the sum of the digits of a number is divisible by 3 (without remainder), the number itself is divisible by 3 (without remainder).

Is it true for these numbers: 15, 18, 36, 39, 351, 216?

- A. Think of each number from 10 to 48. Think whether it can be divided by 3 without remainder. Then think whether it can be divided by 4 without remainder. Then think whether it can be divided by 5 without remainder.
- B. (1) Think of a number that is divisible by 2, by 3, and by 4 without remainder.  
 (2) Think of a number that is divisible by 3, by 4, by 6, and by 8 without remainder.
- C. Write out ten problems that you could solve by canceling. Make five easy problems and five hard problems. Exchange problems with some pupil who sits near you and solve the problems that he gives you.

#### 44. Dividing and Canceling

Numbers like 1, 2, 3, 4, 5, 10, 26, 27, 31, 35, 40, 46 are called whole numbers, or **integers**.

1. What are numbers like  $\frac{1}{2}$ ,  $\frac{3}{4}$ ,  $\frac{9}{5}$ ,  $\frac{11}{12}$ ,  $\frac{5}{2}$ ,  $\frac{7}{3}$  called?

When a number can be divided without remainder by no integers except itself and 1, it is called a **prime number**.

2. Read each of these and tell whether it is a prime number or not. If it is not, tell how you know it is not.

10 11 12 13 14 15 16 17 18 19 20 21

#### 45.

(Use pencil if you need to.)

Reduce each of these fractions to lowest terms when you can. If the fraction is in lowest terms, say, "Is in lowest terms."

1.	2.	3.	4.	5.	6.	7.	8.	9.	10.	11.	12.
$\frac{3}{8}$	$\frac{4}{8}$	$\frac{5}{8}$	$\frac{6}{8}$	$\frac{7}{8}$	$\frac{8}{8}$	$\frac{10}{8}$	$\frac{2}{12}$	$\frac{3}{12}$	$\frac{4}{12}$	$\frac{5}{12}$	$\frac{6}{12}$
13.	14.	15.	16.	17.	18.	19.	20.	21.	22.	23.	24.
$\frac{7}{12}$	$\frac{8}{12}$	$\frac{9}{12}$	$\frac{10}{12}$	$\frac{11}{12}$	$\frac{12}{12}$	$\frac{13}{12}$	$\frac{14}{12}$	$\frac{15}{12}$	$\frac{16}{12}$	$\frac{17}{12}$	$\frac{18}{12}$

A little box 1 in. long, 1 inch wide, and 1 in. high contains 1 cubic inch or 1 cu. in.

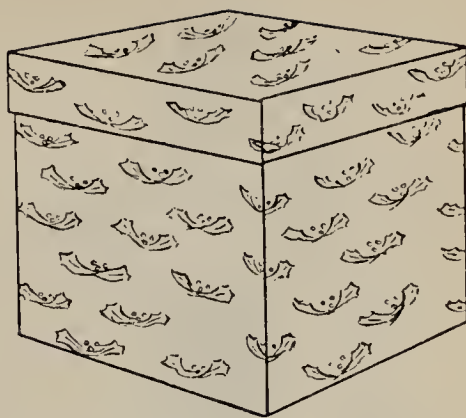

This holds 1 cu. in.

Read, supplying the right numbers where the dots are:

1. A box 3 in. long, 2 in. wide, and 1 in. high holds as much as...boxes each 1 in. long, 1 in. wide, and 1 in. high. It holds...cubic inches.
2. A box 4 in. long, 2 in. wide, and 1 in. high holds as much as...boxes each 1 in. long, 1 in. wide, and 1 in. high. It holds...cu. in.
3. A box 4 in. long, 2 in. wide, and 3 in. high holds...cu. in.
4. Guess how many cubic inches there are in a brick.
5. A brick is 8 in. long, 4 in. wide, and 2 in. high. How many cubic inches does it really contain?
6. How near did you guess?
7. Estimate how many cu. in. there are in a quart of ice cream.
8. A gallon contains 231 cubic inches. How many does a quart contain?
9. How near did you guess?
10. Guess how many cubic inches there are in a shoe box 12 in. long, 6 in. wide, and 3 in. high. Then find out how many there really are by multiplying.



This holds 2 cu. in.



## 47. Measuring Cubical Contents or Volume

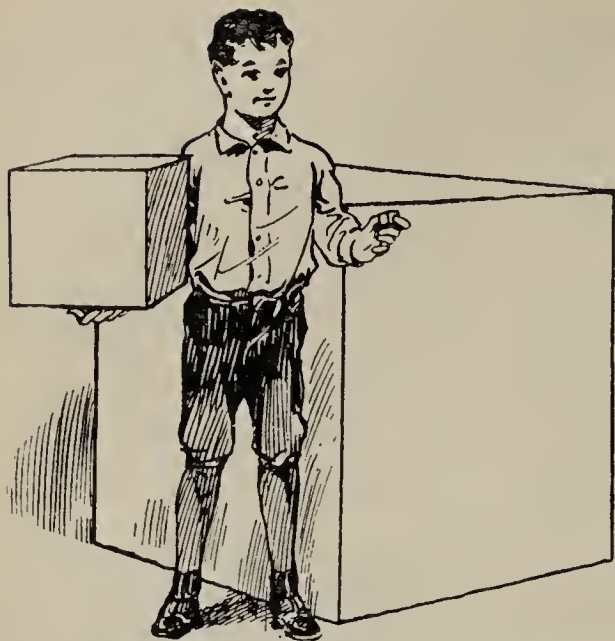

A box 1 ft. long, 1 ft. wide, and 1 ft. deep contains 1 cubic foot or 1 cu. ft.

A box 1 yd. long, 1 yd. wide, and 1 yd. deep contains 1 cubic yard or 1 cu. yd.

1. Tell how many cubic feet each of these boxes contains.

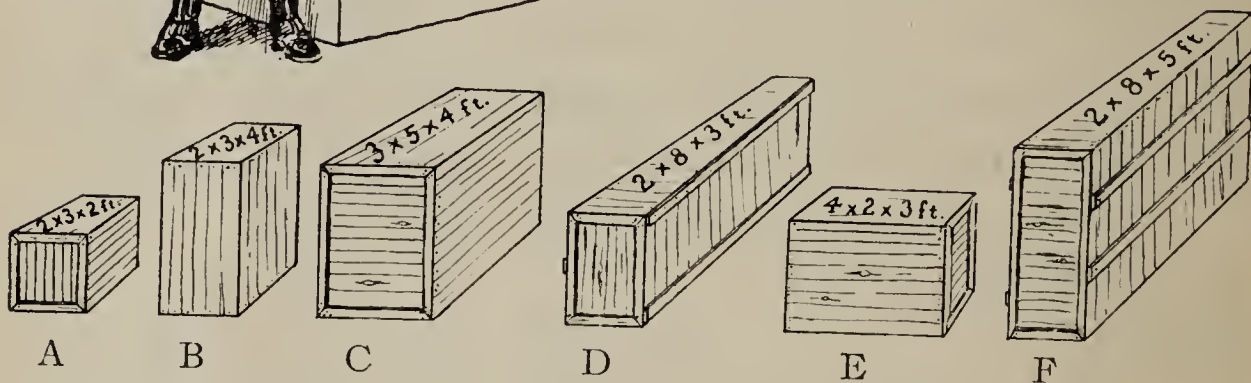

2. Which of them hold more than 1 cubic yard?
3. How high must a box 3 ft. long and 3 ft. wide be to hold a cubic yard?
4. Think how big each of these is and tell whether it will fill about 1 cu. in. or about 1 cu. ft. or about 1 cu. yd. or about 5 cu. yd.:

*An ink well. A bushel basket. A ton of coal.*

*A big trunk. An ice wagon. A box holding 1728 cu. in.*

5. Tell something that is about as big as 10 cu. in.
6. Tell something that is about as big as 50 cu. ft.

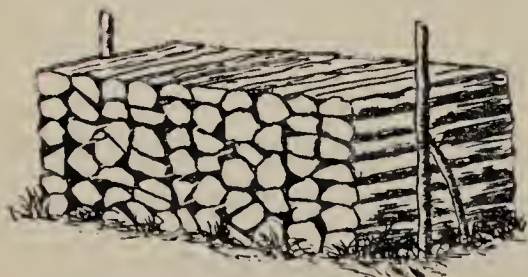

7. This pile of wood is 8 ft. long, 4 ft. wide, and 4 ft. high. How many cubic feet does it occupy?

1. Paul and George built a rectangular reservoir out of cement. It was 18 in. wide and 32 in. long. How many cubic inches of water did it hold (a) When the water was 3 inches deep? (b) When the water was 4 inches deep?



2. Before it began to rain, the water in the reservoir was  $2\frac{3}{4}$  inches deep. After the rain stopped, the water was  $3\frac{3}{4}$  inches deep. How many cubic inches of water had fallen on each square inch of the reservoir's area?
3. During July,  $3\frac{3}{4}$  inches of rain fell on each square inch of area. During August,  $2\frac{5}{8}$  cubic inches fell on each square inch of area. In what month was the rainfall greater? How much greater?
4. How many cubic inches of rain water fell on a garden plot 5 ft. by 8 ft. during July?
5. How many cubic feet of rain water was that? (1728 cu. in. equals 1 cu. ft.)
6. How many cu. in. of rain water fell on this garden plot during August?
7. The rainfall during the entire year in Washington was  $44\frac{1}{2}$  cubic inches per square inch of area. The rainfall in a year in a certain place in Arizona was  $17\frac{1}{4}$  cubic inches per square inch of area. How much greater was the rainfall in Washington?
8. How many cubic feet of water will a tank 8 ft.  $\times$  4 ft.  $\times$  3 ft. hold when it is full to the top?

32      **49. Multiplying with Numbers Smaller Than 1**

1. Count by  $\frac{3}{4}$ s to  $\frac{30}{4}$ , saying, " $2 \times \frac{3}{4} = \frac{6}{4}$ ,  $3 \times \frac{3}{4} = \frac{9}{4}$ ,  $4 \times \frac{3}{4} = \frac{12}{4}$ ," etc.
2. Count by  $\frac{3}{4}$ s to  $7\frac{1}{2}$ , saying, " $2 \times \frac{3}{4} = \frac{6}{4}$  or  $1\frac{1}{2}$ ,  $3 \times \frac{3}{4} = \frac{9}{4}$  or  $2\frac{1}{4}$ ,  $4 \times \frac{3}{4} = \frac{12}{4}$  or 3," etc.
3. Count by  $\frac{5}{6}$ s to  $8\frac{1}{3}$ , saying, " $2 \times \frac{5}{6} = \frac{10}{6}$  or  $1\frac{2}{3}$ ,  $3 \times \frac{5}{6} = \frac{15}{6}$  or  $2\frac{1}{2}$ ,  $4 \times \frac{5}{6} = \frac{20}{6}$  or  $3\frac{1}{3}$ ," etc.

**50.**

1. Multiply  $\frac{2}{3}$  by 2. By 3. By 4. By 5. By 6. By 7. By 8. By 9. By 10. Express each product in lowest terms.
2. Multiply  $\frac{5}{8}$  by each of these numbers: 2, 3, 4, 5, 6, 7, 8, 9, 10. Express each product in lowest terms.
3. Multiply  $\frac{1}{4}$  by each of these numbers: 2, 3, 4, 5, 6, 7, 8, 9, 10, 11, 12. Express each product in lowest terms.
4. Multiply  $\frac{5}{12}$  by each of these numbers: 2, 3, 4, 5, 6, 7, 8, 9, 10, 11, 12. Express the products in lowest terms.
5. Read, supplying the right numbers where the dots are:  
 $\times \frac{3}{4}$  means  $\left\{ \begin{array}{l} \text{multiply by 3 and} \\ \text{divide by } \dots \end{array} \right.$        $\times \frac{7}{8}$  means  $\left\{ \begin{array}{l} \text{multiply by } \dots \text{ and} \\ \text{divide by } \dots \end{array} \right.$   
 $\frac{5}{6} \times$  means  $\left\{ \begin{array}{l} \text{multiply by } \dots \text{ and} \\ \text{divide by } \dots \end{array} \right.$        $\frac{5}{12} \times$  means  $\left\{ \begin{array}{l} \text{multiply by } \dots \text{ and} \\ \text{divide by } \dots \end{array} \right.$
6. Learn this rule:

To multiply by a fraction  $\left\{ \begin{array}{l} \text{multiply by its numerator, and} \\ \text{divide by its denominator.} \end{array} \right.$

7. Find the products. Express them in lowest terms.

A.	B.	C.	D.	E.
$6 \times \frac{3}{4} =$	$3 \times \frac{1}{2} =$	$10 \times \frac{3}{4} =$	$12 \times \frac{1}{3} =$	$3 \times \frac{3}{4} =$
$4 \times \frac{5}{8} =$	$4 \times \frac{2}{3} =$	$8 \times \frac{3}{4} =$	$12 \times \frac{3}{8} =$	$4 \times \frac{5}{8} =$
$9 \times \frac{2}{3} =$	$12 \times \frac{3}{4} =$	$9 \times \frac{1}{2} =$	$9 \times \frac{2}{3} =$	$6 \times \frac{3}{8} =$
$8 \times \frac{5}{12} =$	$8 \times \frac{7}{8} =$	$4 \times \frac{1}{4} =$	$8 \times \frac{2}{3} =$	$2 \times \frac{5}{6} =$



1. Alice, Nell, Bertha, Mary, Kate, and Louise are to be in charge of the candy counter at the Fair. They plan to dress all alike. How many yards of ribbon do they need to make six hair-ribbons, each  $\frac{5}{8}$  yd. long?
2. Check your answer to 1, by adding.
3. If it takes  $\frac{7}{8}$  yd. to make one belt, how many yards do they need to make six belts?
4. Check your answer to 3 by adding.
5. How much ribbon do they need to make six badges, each  $\frac{1}{6}$  yd. long?
6. They plan to sell fudge in  $\frac{1}{4}$ -pound boxes at 10¢ a box, and in  $\frac{3}{4}$ -pound boxes at 25¢ a box. How many pounds of fudge will be required to make two dozen  $\frac{3}{4}$ -lb. boxes?
7. Check your answer to 6 by finding  $\frac{3}{4}$  of 24.
8. If they make 30 pounds of fudge and use 18 pounds to fill the large boxes, how much will be left to fill the 10-cent boxes?
9. How many  $\frac{1}{4}$ -lb. boxes will one pound of fudge fill?
10. How many  $\frac{1}{4}$ -lb. boxes will 12 pounds of fudge fill?
11. They plan to sell salted peanuts in  $\frac{1}{8}$ -lb. bags at 5¢ a bag. How many pounds of salted peanuts will they need to fill 40  $\frac{1}{8}$ -lb. bags?
12. Check your answer to 11 by finding  $40 \times 2$  and dividing the result by 16.
13. The girls made some fancy boxes that hold just 10 caramels each. What part of a pound do 10 caramels weigh if it takes 60 of them to weigh a pound?
14. They mark each box, "Containing . . . oz. caramels." What number shall they put before the "oz."?



## 52. How Much for 5¢, 10¢, 25¢?

The girls had candy to sell at 20¢, 25¢, 30¢, 40¢, 50¢, 60¢, 75¢, and 80¢ a pound. They were trying to decide how much candy to give as 5¢ worth when the price was 25¢ or 30¢ or 50¢ or 75¢ per pound. They decided to use the nearest half ounce below the exact weight. So they made a table like this:

Price per Pound	Exact Weight in Ounces	Weight to Nearest Half Ounce Below Exact Weight
At 25¢, 5¢ worth is $\frac{5}{25}$ lb. or $\frac{1}{5}$ lb.	$\frac{1}{5} \times 16 = 3\frac{1}{5}$ .	Give 3 ounces.
At 30¢, 5¢ worth is $\frac{5}{30}$ lb. or $\frac{1}{6}$ lb.	$\frac{1}{6} \times 16 = 2\frac{2}{3}$ .	Give 2½ ounces.
At 40¢, 5¢ worth is		
At 50¢, 5¢ worth is		
At 60¢, 5¢ worth is		
At 75¢, 5¢ worth is		
At 80¢, 5¢ worth is		

1. Complete the table.

Then they made a “10¢ worth” table, beginning

At 25¢, 10¢ worth is $\frac{10}{25}$ lb. or $\frac{2}{5}$ lb.	$\frac{2}{5} \times 16 = 6\frac{2}{5}$ .	Give 6 ounces.
At 30¢, 10¢ worth is		
At 40¢, 10¢ worth is		
At 50¢, 10¢ worth is		
At 60¢, 10¢ worth is		
At 75¢, 10¢ worth is		
At 80¢, 10¢ worth is		

2. Complete this table.

They made a “25¢ worth” table, beginning

At 25¢, 25¢ worth is 1 pound.		
At 30¢, 25¢ worth is $\frac{25}{30}$ or $\frac{5}{6}$ lb.	$\frac{5}{6} \times 16 = \frac{80}{6}$ or $13\frac{1}{3}$ .	Give 13 ounces.
At 40¢, 25¢ worth is		
At 50¢, 25¢ worth is		
At 60¢, 25¢ worth is		
At 75¢, 25¢ worth is		
At 80¢, 25¢ worth is		

3. Complete the “25¢ worth” table.

1. Make out a multiplication table for  $\frac{3}{8}$  like the one shown below for  $\frac{5}{8}$ .

Cancel when you can.

$$1 \times \frac{5}{8} = \frac{5}{8}$$

$$2 \times \frac{5}{\cancel{8}} = \frac{5}{4} \text{ or } 1\frac{1}{4}$$

$$3 \times \frac{5}{8} = \frac{15}{8} \text{ or } 1\frac{7}{8}$$

$$4 \times \frac{5}{\cancel{8}} = \frac{5}{2} \text{ or } 2\frac{1}{2}$$

$$5 \times \frac{5}{8} = \frac{25}{8} \text{ or } 3\frac{1}{8}$$

$$\cancel{6} \times \frac{5}{\cancel{8}} = \frac{15}{4} \text{ or } 3\frac{3}{4}$$

$$7 \times \frac{5}{8} = \frac{35}{8} \text{ or } 4\frac{3}{8}$$

$$8 \times \frac{5}{8} = 5$$

$$9 \times \frac{5}{8} = \frac{45}{8} \text{ or } 5\frac{5}{8}$$

$$\cancel{10} \times \frac{5}{\cancel{8}} = \frac{25}{4} \text{ or } 6\frac{1}{4}$$

2. Make out a multiplication table for each of these:

$$\frac{2}{3} \quad \frac{3}{4} \quad \frac{5}{6} \quad \frac{1}{8} \quad \frac{7}{12}$$

3. Make out a multiplication table for  $\frac{5}{12}$  like the one shown below for  $\frac{9}{16}$ .

$$\frac{9}{16} \times 1 = \frac{9}{16}$$

$$\frac{9}{\cancel{16}} \times 2 = \frac{9}{8} \text{ or } 1\frac{1}{8}$$

$$\frac{9}{16} \times 3 = \frac{27}{16} \text{ or } 1\frac{11}{16}$$

$$\frac{9}{\cancel{16}} \times 4 = \frac{9}{4} \text{ or } 2\frac{1}{4}$$

$$\frac{9}{16} \times 5 = \frac{45}{16} \text{ or } 2\frac{9}{16}$$

$$\frac{9}{\cancel{16}} \times \cancel{6} = \frac{27}{8} \text{ or } 3\frac{3}{8}$$

$$\frac{9}{16} \times 7 = \frac{63}{16} \text{ or } 3\frac{15}{16}$$

$$\frac{9}{\cancel{16}} \times 8 = \frac{9}{2} \text{ or } 4\frac{1}{2}$$

$$\frac{9}{16} \times 9 = \frac{81}{16} \text{ or } 5\frac{1}{16}$$

$$\frac{9}{\cancel{16}} \times \cancel{10} = \frac{45}{8} \text{ or } 5\frac{5}{8}$$

4. Make out a multiplication table like that printed above, for each of these:

$$\frac{3}{4} \quad \frac{4}{5} \quad \frac{7}{8} \quad \frac{1}{3} \quad \frac{3}{16}$$

### 54. Finding the Product of a Fraction and an Integer

Find the products. Cancel when you can. Express each product in lowest terms.

- |                             |                             |                             |                              |                              |
|-----------------------------|-----------------------------|-----------------------------|------------------------------|------------------------------|
| 1. $6 \times \frac{3}{4}$   | 2. $10 \times \frac{3}{4}$  | 3. $12 \times \frac{1}{2}$  | 4. $\frac{1}{3} \times 5$    | 5. $\frac{1}{3} \times 12$   |
| 6. $5 \times \frac{3}{8}$   | 7. $12 \times \frac{3}{4}$  | 8. $9 \times \frac{5}{6}$   | 9. $\frac{2}{3} \times 10$   | 10. $\frac{3}{16} \times 15$ |
| 11. $18 \times \frac{3}{8}$ | 12. $6 \times \frac{7}{8}$  | 13. $6 \times \frac{1}{2}$  | 14. $\frac{5}{8} \times 12$  | 15. $\frac{3}{8} \times 12$  |
| 16. $6 \times \frac{5}{6}$  | 17. $18 \times \frac{1}{6}$ | 18. $24 \times \frac{1}{8}$ | 19. $\frac{5}{12} \times 24$ | 20. $\frac{5}{16} \times 24$ |
| 21. $25 \times \frac{4}{5}$ | 22. $5 \times \frac{3}{5}$  | 23. $18 \times \frac{2}{3}$ | 24. $\frac{1}{2} \times 8$   | 25. $\frac{3}{4} \times 3$   |
| 26. $12 \times \frac{3}{8}$ | 27. $8 \times \frac{7}{8}$  | 28. $15 \times \frac{5}{8}$ | 29. $\frac{7}{12} \times 16$ | 30. $\frac{2}{3} \times 4$   |

### 55.

- One small dish towel requires  $\frac{3}{8}$  yd. cloth. How much cloth is needed to make a dozen?
- How much cloth is needed to make a dozen towels, each requiring  $\frac{3}{4}$  yd.?
- How much cloth is needed to make 8 towels, each  $\frac{7}{8}$  yd. long?
- A piece of cloth 10 yards long is cut into 6 equal pieces. How long will each piece be?
- How much will be left of a 10-yard piece of cloth after cutting a dozen pieces  $\frac{5}{8}$  yd. long from it?
- How much cloth  $\frac{1}{2}$  yd. wide will be required to make 6 curtains  $\frac{1}{2}$  yd. wide, 28 in. long, and with a hem of 2 in. at each end?
- Find the exact cost of  $\frac{7}{8}$  yd. cloth at 25¢ a yard.
- What would the clerk really charge for the cloth in No. 7?
- What is the exact cost of  $\frac{3}{4}$  yd. cloth at 50¢ a yard?
- What would the clerk really charge for the cloth in No. 9?

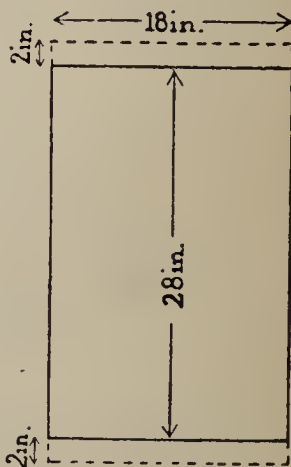

Remember that " $\frac{1}{2} \times$ " means " $\frac{1}{2}$  of."

1. What part of a dollar is  $\frac{1}{2} \times \frac{1}{2}$  dollar?
2. Check your result by finding  $\frac{1}{2}$  of 50 cents, and finding what part of 100 cents 25 cents are.
3. What part of a pound is  $\frac{3}{4} \times \frac{1}{2}$  lb.?
4. Check your result by finding  $\frac{3}{4} \times 8$  oz. and finding what part of 16 ounces 6 ounces are.
5. What part of a foot is  $\frac{2}{3} \times \frac{3}{4}$  ft.?
6. Check your result by drawing a line  $\frac{3}{4}$  ft. long, and finding  $\frac{2}{3}$  of it.
7. What part of a dozen is  $\frac{1}{2} \times \frac{1}{2}$  dozen?
8. What part of a yard is  $\frac{3}{4} \times \frac{2}{3}$  yard?
9. Check your result by a drawing like this:
 

Call	<div style="position: absolute; left: 0; top: -5px;"> </div> <div style="position: absolute; left: 50%; top: -5px;"> </div> <div style="position: absolute; left: 100%; top: -5px;"> </div>	1 yd.
Then	<div style="position: absolute; left: 0; top: -5px;"> </div> <div style="position: absolute; left: 50%; top: -5px;"> </div> <div style="position: absolute; left: 100%; top: -5px;"> </div>	$= \frac{2}{3}$ yd.
and	<div style="position: absolute; left: 0; top: -5px;"> </div> <div style="position: absolute; left: 50%; top: -5px;"> </div> <div style="position: absolute; left: 100%; top: -5px;"> </div>	$= \frac{3}{4}$ of $\frac{2}{3}$ yd.

**In multiplying with fractions:**

Write the product of the numerators as numerator. Write the product of the denominators as denominator. Cancel when you can.

## 57.

Find the products. You may check your results by drawing and measuring with a foot rule.

A.

$$\begin{aligned} \frac{1}{2} \times \frac{1}{4} \text{ in.} &= \\ \frac{1}{2} \times \frac{1}{2} \text{ in.} &= \\ \frac{1}{2} \times \frac{3}{4} \text{ in.} &= \\ \frac{1}{2} \times 1 \text{ in.} &= \\ \frac{1}{2} \times 1\frac{1}{4} \text{ (or } \frac{5}{4}) \text{ in.} &= \\ \frac{1}{2} \times 1\frac{1}{2} \text{ (or } \frac{3}{2}) \text{ in.} &= \\ \frac{1}{2} \times 1\frac{3}{4} \text{ (or } \frac{7}{4}) \text{ in.} &= \end{aligned}$$

B.

$$\begin{aligned} \frac{2}{3} \times \frac{1}{4} \text{ ft.} &= \\ \frac{2}{3} \times \frac{1}{2} \text{ ft.} &= \\ \frac{2}{3} \times \frac{3}{4} \text{ ft.} &= \\ \frac{2}{3} \times 1 \text{ ft.} &= \\ \frac{2}{3} \times 1\frac{1}{4} \text{ (or } \frac{5}{4}) \text{ ft.} &= \\ \frac{2}{3} \times 1\frac{1}{2} \text{ (or } \frac{3}{2}) \text{ ft.} &= \\ \frac{2}{3} \times 1\frac{3}{4} \text{ (or } \frac{7}{4}) \text{ ft.} &= \end{aligned}$$

C.

$$\begin{aligned} \frac{3}{4} \times \frac{1}{3} \text{ yd.} &= \\ \frac{3}{4} \times \frac{2}{3} \text{ yd.} &= \\ \frac{3}{4} \times 1 \text{ yd.} &= \\ \frac{3}{4} \times 1\frac{1}{3} \text{ yd.} &= \\ \frac{3}{4} \times 1\frac{2}{3} \text{ yd.} &= \\ \frac{4}{5} \times \frac{1}{2} \text{ in.} &= \\ \frac{4}{5} \times 1 \text{ in.} &= \end{aligned}$$



## 58. Multiplying a Fraction by a Fraction

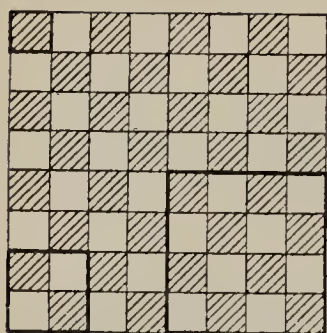

A

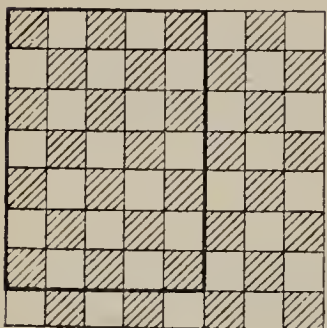

B

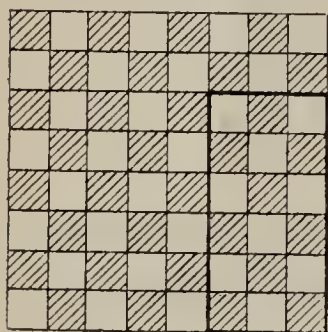

C

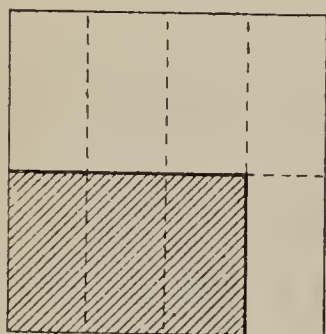

D

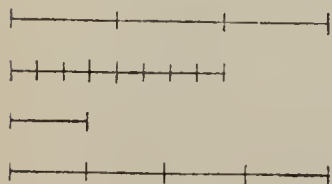

E

1. How many square inches are there in a rectangle  $2\frac{1}{2}$  in. by  $\frac{1}{2}$  in.?  
 $\frac{5}{2} \times \frac{1}{2} =$
2. How many square inches are there in a rectangle  $2\frac{1}{2}$  in. by  $1\frac{1}{2}$  in.?  
 $\frac{5}{2} \times \frac{3}{2} =$
3. Show by a drawing that  $3\frac{3}{4}$  sq. in. is the right answer to problem 2.
4. What is the area in square inches of a square  $\frac{1}{2}$  by  $\frac{1}{2}$  in.? ( $\frac{1}{2}$  by  $\frac{1}{2}$  in. means  $\frac{1}{2}$  in. by  $\frac{1}{2}$  in. In general, in describing an area, the measure stated after the last dimension applies to the other also.)
5. Of a square  $\frac{1}{4}$  by  $\frac{1}{4}$  in.?
6. Of a square  $\frac{1}{8}$  by  $\frac{1}{8}$  in.?
7. Of a rectangle  $\frac{5}{8}$  in. by  $\frac{7}{8}$  in.?
8. Of a rectangle  $\frac{3}{8}$  in. by  $\frac{3}{4}$  in.?
9. Of a rectangle  $1\frac{1}{8}$  in. by  $1\frac{3}{8}$  in.?
10. Which drawing shows that  $\frac{6}{8} \times \frac{3}{8} = \frac{18}{64}$ ?
11. Which drawing shows that  $\frac{3}{8} \times \frac{2}{3} = \frac{1}{4}$ ?
12. Which drawing shows that  $\frac{3}{4} \times \frac{1}{2} = \frac{3}{8}$ ?
13. Which drawing shows the right answer for problem 4?
14. Which drawing shows the right answer for problem 5?
15. Which drawing shows the right answer for problem 6?
16. Which drawing shows the right answer for problem 7?
17. Make a drawing to show that your answer for problem 8 is right.

In multiplying with mixed numbers write each mixed number as a fraction. Write the product of the numerators as numerator. Write the product of the denominators as denominator. Cancel when you can.

1. How many cubic inches will a box  $2\frac{5}{8}$  in. by  $2\frac{2}{3}$  in. by  $2\frac{1}{2}$  in. (inside measure) hold?

$$\frac{21}{8} \times \frac{8}{3} \times \frac{5}{2} = \frac{35}{2} \text{ or } 17\frac{1}{2}. \text{ The answer is } 17\frac{1}{2} \text{ cu. in.}$$

2. How many cubic inches will a box  $3\frac{3}{4}$  in. by  $2\frac{2}{3}$  in. by  $2\frac{1}{5}$  in. (inside dimensions) hold?
3. Which holds more, a can  $4\frac{1}{2}$  in. by  $4\frac{1}{2}$  in. by  $4\frac{1}{2}$  in. or a can  $8\frac{1}{2}$  in. by  $8\frac{1}{2}$  in. by  $1\frac{1}{2}$  in.? How much more?

We may write 4" for 4 inches,  $1\frac{1}{2}$ " for  $1\frac{1}{2}$  inches, etc. In such cases, " means inches or inch. We may write 3' for 3 feet,  $6\frac{3}{4}$ ' for  $6\frac{3}{4}$  feet, etc. In such cases, ' means feet or foot.

4. 1 pint (liquid) holds  $28\frac{7}{8}$  cu. in. How much more does a can  $3\frac{1}{4}$ " by  $3\frac{1}{2}$ " by  $3\frac{1}{3}$ " (inside measure) hold?
5. How many cubic feet will each of these chests contain?  
Chest A, inside dimensions,  $3\frac{1}{2}' \times 2\frac{1}{4}'$  by  $2\frac{1}{2}'$ .  
Chest B, inside dimensions,  $3\frac{1}{2}' \times 2\frac{3}{4}'$  by  $2'$ .
6. How many cubic inches of water are there in a square can  $10\frac{1}{2}$  in. by  $10\frac{1}{2}$  in. when the water is  $2\frac{1}{2}$  inches deep?
7. How many cubic inches of water are there in this can when the water is 6 inches deep?
8. When the water is 8 inches deep, how many gallons of water are in the can? 1 gallon equals 231 cu. in.

## 60.

State the products:

A.	B.	C.	D.	E.
$\frac{1}{2}$ of $\frac{1}{2}$	$\frac{1}{3}$ of $\frac{1}{2}$	$\frac{3}{4}$ of $\frac{3}{4}$	$\frac{1}{5}$ of $\frac{1}{2}$	$\frac{1}{4}$ of 5
$\frac{1}{2}$ of $\frac{1}{3}$	$\frac{1}{3}$ of 1	$\frac{3}{4}$ of $\frac{1}{4}$	$\frac{1}{5}$ of $\frac{1}{3}$	$\frac{1}{3}$ of 8
$\frac{1}{2}$ of $\frac{3}{4}$	$\frac{1}{3}$ of $1\frac{1}{2}$	$\frac{3}{4}$ of 4	$\frac{1}{5}$ of $\frac{1}{4}$	$\frac{1}{6}$ of 5

## 61. Providing Seed: Seed Mixtures

Amount of Seed Usually Sown per Acre	1. State the number of pounds of each sort of seed required for 2 acres, for 3 acres, and for 4 acres. Say, "Using alfalfa seed, it requires 40 lb. for 2 acres, 60 lb. for 3 acres, 80 lb. for 4 acres. Using barley, it requires 180 lb. for 2 acres, 270 lb. for 3 acres," and so on.
Alfalfa . . . . . 20 lb.	
Barley . . . . . 90 lb.	
Bluegrass . . 25 lb.	
Buckwheat . 52 lb.	
Clover . . . . . 12 lb.	
Field Corn 8 lb.	
Flax . . . . . 56 lb.	

2. Tell how much is required of each sort of seed for  $\frac{1}{2}$  acre.
3. Tell how much is required for  $\frac{1}{4}$  acre.
4. How many pounds of alfalfa seed are required to sow a field containing  $28\frac{3}{4}$  A.?
5. How many bushels of seed will that be, counting 60 lb. to the bushel?
6. How many pounds of bluegrass seed are required to sow an 18-acre field?
7. How many bushels of seed will that be, counting 14 lb. to the bushel?
8. A farmer plans to sow 80 lb. of grass seed mixed in this way: 2 parts timothy, 1 part redtop, and 1 part bluegrass. (This means that two fourths is to be timothy, one fourth redtop, and one fourth bluegrass.) How many pounds of each sort of seed does he need?
9. If he mixed the seed in this way how many pounds of each would he need?  
4 parts timothy, 3 parts redtop, 1 part bluegrass.
10. If he used 3 parts timothy and 2 parts redtop, how many pounds of each would he use to make the 80 lb.?
11. A farmer feeds his cows 2 parts corn and 5 parts hay. If a cow eats 35 lb. of feed per day, how many pounds of each does she eat?



Write the products:

- |                                      |                                    |                                    |                                     |                         |
|--------------------------------------|------------------------------------|------------------------------------|-------------------------------------|-------------------------|
| 1.                                   | 2.                                 | 3.                                 | 4.                                  | 5.                      |
| $\frac{2}{5} \times \frac{15}{24}$   | $3\frac{3}{8} \times 1\frac{1}{3}$ | $\frac{3}{4} \times \frac{5}{6}$   | $1\frac{1}{2} \times 5$             | $10 \times \frac{5}{6}$ |
| 6.                                   | 7.                                 | 8.                                 | 9.                                  | 10.                     |
| $3\frac{1}{2} \times 2\frac{2}{3}$   | $\frac{9}{10} \times \frac{5}{18}$ | $2\frac{2}{5} \times 3\frac{1}{8}$ | $\frac{7}{8} \times 10$             | $12 \times \frac{3}{4}$ |
| 11.                                  | 12.                                | 13.                                | 14.                                 | 15.                     |
| $\frac{1}{2} \times \frac{6}{5}$     | $\frac{1}{8} \times \frac{2}{3}$   | $5\frac{1}{2} \times 3\frac{3}{4}$ | $24 \times \frac{5}{6}$             | $9 \times 2\frac{1}{2}$ |
| 16.                                  | 17.                                | 18.                                | 19.                                 | 20.                     |
| $10\frac{1}{4} \times 10\frac{1}{3}$ | $4\frac{1}{6} \times 7\frac{1}{6}$ | $5\frac{3}{8} \times 9\frac{2}{3}$ | $12\frac{1}{8} \times 1\frac{3}{8}$ | $24 \times \frac{7}{8}$ |

### 63. Planting Fruit Trees and Small Fruits

#### Space to Allow per Tree or Plant in Planting

<i>Standard Apple Trees</i> 36 by 36 ft.	<i>Plum Trees</i> 18 by 18 ft.
<i>Dwarf Apple Trees</i> 8 by 10 ft.	<i>Quince Trees</i> 11 by 11 ft.
<i>Standard Pear Trees</i> 18 by 18 ft.	<i>Currants</i> 3 by 5 ft.
<i>Dwarf Pear Trees</i> 8 by 10 ft.	<i>Raspberries</i> 3 by 6 ft.
<i>Peach Trees</i> 18 by 18 ft.	<i>Blackberries</i> 5 by 7 ft.

**1 acre equals 43,560 sq. ft.**

Suppose that you allow space for each tree or plant as stated in the table.

- How many standard apple trees are needed for a 10-acre orchard?
- How many blackberry plants are needed for  $\frac{1}{10}$  acre?
- How many peach trees are needed for 2 acres?
- How many currant bushes are needed for  $\frac{1}{8}$  acre?
- How many raspberry plants are needed for 1 acre?
- How many dwarf apple trees for a plot of 8000 sq. ft.?
- How much space do you need for 50 quince trees?
- How much space do you need for 100 currant bushes?
- How much space do you need for 20 standard pear trees and 20 dwarf pear trees?



**Standard Pear Trees: Anjou, Bartlett, Clapp, Duchess,  
Sheldon, etc.**

	Each	10	100
<i>Extra size, XXX</i>	\$0.35	\$3.00	\$25.00
<i>Orchard size, XX</i>	.30	2.50	20.00
<i>Smaller size, X</i>	.20	1.75	12.50

**Quantities from 10 to 49 sold at the rate for 10.**

**Quantities of 50 and over sold at the rate for 100.**

At these prices find the cost of —

- 3 XXX and 3 XX trees.
- 20 Bartlett and 10 Duchess, both XXX size.
- 15 XXX Anjou, 15 XX Bartlett, and 10 X Duchess.
- 250 XXX trees.
- 125 XX trees.
- What is the cost per tree for XXX trees when you buy 10 at a time?
- When you buy 100 at a time?
- What is the cost per tree for XX trees when you buy 10 at a time?
- When you buy 100 at a time?
- How many times as much do 100 XXX trees cost as 100 X trees?
- How many XX trees can you get for the price of 100 XXX trees?

**65. Camping**

In taking food for a camping trip, hunters count  $2\frac{1}{8}$  lb. per man per day for a summer trip and  $2\frac{1}{2}$  lb. per man per day for a winter trip.

What is the weight of the food to be taken —

- On a summer trip of 70 days for 2 men?
- On a summer trip of 12 days for 3 men?
- On a winter trip of 14 days for 2 men?

4. On a winter trip of 21 days for 3 men?
5. How much more is required per man per day for a winter trip than for a summer trip?

If fresh vegetables and canned meats are taken, hunters count on  $3\frac{7}{8}$  lb. per man per day for a summer trip and  $4\frac{1}{8}$  lb. per man per day for a winter trip.

How much is the weight with vegetables and canned meats —

6. For 6 men for a day on a summer trip?    7. On a winter trip?
8. For 1 man for 6 days on a summer trip?
9. For 8 men for 7 days on a winter trip?

Suppose that a crew of 24 men are shipwrecked on a desert island, and have only 5000 pounds of food.

10. How much food will they use per day if each man has  $3\frac{1}{8}$  lb., and how long will the 5000 lb. last?
11. How much will they use per day if each man has  $2\frac{5}{8}$  lb., and how long will the 5000 lb. last?
12. If each man has only  $1\frac{7}{8}$  lb. per day how long will the 5000 lb. last?
13. They feel sure some ship will come within four months or 125 days. How many pounds per day can they use and have the 5000 lb. last 125 days? How much food will that allow each man of the 24 to have per day?
14. They have 15 kegs of water, each containing 20 gallons. How many pints of water have they?
15. If each of the 24 men is allowed 1 pint a day, how long will the water last them?
16. If each of the 24 men is allowed  $1\frac{1}{2}$  pt. of water per day, how much water will they use in a day?
17. How long will the water last if each man has  $1\frac{1}{2}$  pt. per day?
18. If each of the 24 men has only  $\frac{5}{8}$  pt. of water per day, how much will they use in a day?

- Find the number of square feet of floor space in each of these tents. Write the letters A, B, C, D, and E in a column. Write the number of square feet of floor space of each tent after its letter.

**Special Waterproof Tents**

Size	Length	Width	Price
A	$7\frac{1}{6}$	$7\frac{1}{6}$	\$ 9.55
B	$7\frac{1}{6}$	$9\frac{1}{2}$	11.50
C	$9\frac{1}{2}$	$11\frac{5}{6}$	15.55
D	$11\frac{5}{6}$	$11\frac{5}{6}$	18.75
E	$11\frac{5}{6}$	$14\frac{1}{4}$	19.90

- Which size has about 2 times as much floor space as size A?
- Which has about three times as much floor space as size A?
- Which has about  $1\frac{1}{3}$  times as much as size A?
- How much more floor space has size B than size A?
- Which size costs about  $1\frac{1}{2}$  times as much as size A?
- Which size costs about twice as much as size A?
- Which size costs about  $1\frac{1}{5}$  times as much as size A?

## 67.

- How many boxes of cartridges, size A, can be bought for \$5.00 and how many cents will be left over?

Prices of Cartridges per Box	
Size A	\$.42
Size B	.68
Size C	.73

When both the dividend and the divisor mean amounts of money, express both as dollars or express both as cents. Then divide.

*In example 1 use either  $.42\overline{)5.00}$  or  $42\overline{)500}$ .*

- How many boxes of size B can be bought for \$5.00 and how many cents will be left over?
- How many boxes of size C can be bought for \$10.00 and how many cents will be left over?



1. How many tent pegs 8 inches long can be cut from a piece of wood 4 ft. long?

When both the dividend and the divisor mean lengths, express both in the same unit. Write both as inches, or both as feet, or both as yards, or both as rods, or both as miles. Then divide.

*In example 1 use  $8\overline{)48}$ .*

2. How many tent pegs 9 inches long can be cut from a piece of wood 6 ft. long?
3. How many 5-yard lengths can be cut from 360 ft. of rope?

When both the dividend and the divisor mean areas, express both in the same unit. Write both as sq. in., or both as sq. ft., or both as sq. yd., or both as sq. rd., or both as acres, or both as sq. mi. Then divide.

4. How many sq. yd. are there in a rug  $9 \times 13$  ft.?
5. How many slips  $3 \times 4$  in. can be cut from a sheet of paper 2 ft. by  $2\frac{1}{2}$  ft.?

## 69.

Learn these:

$$1 \text{ sq. ft.} = 144 \text{ sq. in.} \quad 1 \text{ acre (1A.)} = 160 \text{ sq. rd.}$$

$$1 \text{ mile} = 320 \text{ rods.} \quad 1 \text{ square mile} = 640 \text{ acres.}$$

Find the missing numbers:

- |                                |   |
|--------------------------------|---|
| a. 7 ft. = ... 21-inch lengths | l. $\frac{1}{2}$ sq. ft. = ... areas each 9 sq. in. |
| b. 2 yd. = ... 9-inch lengths  | m. 10 sq. yd. = ... areas each 10 sq. ft.           |
| c. 2 rd. = ... 11-ft. lengths  | n. 72 sq. ft. = ... areas each 4 sq. yd.            |
| d. 2 mi. = ... 64-rod lengths  | o. $\frac{1}{2}$ sq. mi. = ... 32-acre areas        |
| e. 5 ft. = ... 10-inch lengths | p. $\frac{1}{10}$ sq. mi. = ... 8-acre areas        |
| f. 54 ft. = ... 2-yard lengths | q. 2 acres = ... areas each 10 sq. rd.              |
| g. 240 ft. = ... 2-ft. lengths | r. 2 acres = ... areas each 80 sq. rd.              |
| h. 1 mi. = ... 528-ft. lengths | s. 1600 sq. rd. = ... acres                         |
| i. 1 mi. = ... 10-rod lengths  | t. 288 sq. in. = ... sq. ft.                        |
| j. 960 rd. = ... miles         | u. \$1.75 will buy ... 25-cent articles             |
| k. 400 rd. = one mile and ...  | v. \$3.00 will buy ... 15-cent articles             |



## 70. Athletic Records

In the Washington School the records for boys in certain athletic sports were as follows:

	10-Year Old	11-Year Old	12-Year Old	13-Year Old	14-Year Old
100-yard dash . . . . .	14sec.	$13\frac{2}{5}$ sec.	$13\frac{1}{5}$ sec.	$12\frac{3}{5}$ sec.	$12\frac{1}{5}$ sec.
Running high jump	$3\frac{1}{2}$ ft.	$3\frac{1}{4}$ ft.	$3\frac{1}{2}$ ft.	$3\frac{1}{12}$ ft.	$4\frac{1}{12}$ ft.
Running broad jump	$10\frac{1}{2}$ ft.	$12\frac{1}{4}$ ft.	$13\frac{7}{12}$ ft.	$15\frac{1}{12}$ ft.	16 ft.

1. How many seconds was the difference between the 10-year-old record in the 100-yard dash and the 14-year-old record?
2. Between the 11-year-old record and the 13-year-old record?
3. How much higher was the 14-year-old record in the running high jump than the 12-year-old record?
4. How much higher was it than the 11-year-old record?
5. Find the difference between each of the records of the Washington School in the 100-yard dash and the West Point record of  $9\frac{4}{5}$  sec.

## 71.

The 5th-grade record in the Washington School for the number of these exercises done correctly in 10 minutes is: Superior Computers, 23; Ordinary Children, 16; Slow Computers, 7. What is your record?

- |                               |                                |                                |
|-------------------------------|--------------------------------|--------------------------------|
| 1. $356 \times 297$           | 9. $517 \times 648$            | 17. $450 \times 275$           |
| 2. $270 \times 915$           | 10. $309 \times 479$           | 18. $615 \times 388$           |
| 3. $905 \times 812$           | 11. $736 \times 865$           | 19. $348 \times 392$           |
| 4. $518 \times 791$           | 12. $420 \times 976$           | 20. $360 \times 858$           |
| 5. $703 \times 909$           | 13. $605 \times 884$           | 21. $950 \times 765$           |
| 6. $15\frac{1}{2} \times 476$ | 14. $57\frac{1}{3} \times 189$ | 22. $28\frac{1}{5} \times 255$ |
| 7. $27\frac{1}{4} \times 360$ | 15. $41\frac{2}{3} \times 234$ | 23. $63\frac{1}{2} \times 968$ |
| 8. $36\frac{3}{4} \times 144$ | 16. $19\frac{1}{4} \times 240$ | 24. $45\frac{1}{4} \times 132$ |

The 5th-grade children had a FRACTIONS DASH. The teacher put 10 problems on the blackboard in a column like the one at the left of this page, and covered them with a chart. When she uncovered them, each boy and girl raced to write the correct answers as quickly as he or she could. The best record was 39 sec., by a girl. Practice with the exercises at the right of the page. Then try to beat the record. Your record does not count unless all answers are correct and are expressed in lowest terms.

FRACTIONS  
DASH

Material for Practice for Fractions Dash

$$\begin{array}{r} \text{Add } 8\frac{1}{8} \\ 3\frac{1}{2} \\ \hline \end{array}$$

$$\begin{array}{r} \text{Add } 2\frac{3}{4} \\ 3\frac{3}{4} \\ \hline \end{array}$$

$$\begin{array}{r} \text{Add } 2\frac{1}{4} \\ 3\frac{7}{12} \\ \hline \end{array}$$

Addition

$$\text{A. } \begin{array}{cccccc} 5\frac{5}{16} & 9\frac{1}{3} & 9\frac{5}{8} & 8\frac{3}{4} & 7\frac{7}{12} & 1\frac{2}{3} \\ \hline 9\frac{1}{4} & 2\frac{1}{6} & 9\frac{3}{4} & 3\frac{2}{3} & 8\frac{1}{2} & 1\frac{1}{4} \end{array}$$

$$\text{B. } \begin{array}{cccccc} 9\frac{3}{8} & 2\frac{1}{6} & 9\frac{7}{8} & 9\frac{1}{2} & 7\frac{3}{4} & 5\frac{1}{4} \\ \hline 8\frac{1}{2} & 2\frac{5}{12} & 3\frac{1}{4} & 5\frac{3}{16} & 4\frac{5}{8} & 4\frac{3}{4} \end{array}$$

$$\text{C. } \begin{array}{cccccc} 9\frac{3}{8} & 9\frac{3}{4} & 8\frac{1}{3} & 7\frac{7}{12} & 9\frac{3}{8} & 8\frac{2}{3} \\ \hline 7\frac{7}{8} & 4\frac{3}{4} & 4\frac{2}{3} & 9\frac{11}{12} & 8\frac{5}{8} & 8\frac{2}{3} \end{array}$$

$$\begin{array}{r} \text{Subt. } 7 \\ 2\frac{1}{2} \\ \hline \end{array}$$

$$\begin{array}{r} \text{Subt. } 8\frac{1}{4} \\ 2\frac{7}{8} \\ \hline \end{array}$$

Subtraction

$$\text{A. } \begin{array}{cccccc} 8 & 7 & 5 & 6 & 9 & 4 \\ \hline 2\frac{1}{2} & 2\frac{2}{3} & 3\frac{5}{8} & 3\frac{7}{12} & 5\frac{9}{16} & 1\frac{3}{4} \end{array}$$

$$\text{B. } \begin{array}{cccccc} 9\frac{1}{8} & 6\frac{1}{3} & 7\frac{3}{8} & 21\frac{2}{5} & 3\frac{1}{3} & 8\frac{3}{4} \\ \hline 4\frac{1}{2} & 1\frac{1}{6} & 5\frac{7}{8} & 11\frac{4}{5} & 1\frac{3}{4} & 7\frac{11}{16} \end{array}$$

$$\frac{5}{2} \times \frac{8}{10}$$

$$1. \frac{2}{3} \times \frac{3}{4} \quad 2. \frac{1}{2} \times \frac{2}{3} \quad 3. \frac{3}{8} \times \frac{3}{4} \quad 4. \frac{5}{6} \times \frac{1}{2}$$

$$17 \times \frac{1}{4}$$

$$5. \quad 6. \quad 7. \quad 8.$$

$$\frac{1}{3} \times \frac{5}{8}$$

$$15 \times \frac{2}{3} \quad 15 \times \frac{3}{5} \quad 15 \times \frac{1}{2} \quad 5 \times \frac{3}{8}$$

$$1\frac{1}{2} \times 2\frac{1}{4}$$

$$9. \quad 10. \quad 11. \quad 12.$$

$$1\frac{1}{2} \times 50$$

$$\frac{1}{2} \times \frac{1}{3} \quad \frac{1}{4} \times \frac{1}{3} \quad \frac{3}{4} \times \frac{3}{4} \quad 1\frac{1}{4} \times 1\frac{1}{2}$$

$$13. \quad 14. \quad 15. \quad 16.$$

$$2\frac{1}{2} \times 40 \quad 3\frac{1}{3} \times \frac{2}{5} \quad \frac{5}{8} \times 1\frac{1}{2} \quad 10\frac{1}{2} \times 8\frac{1}{3}$$

The children in Grade 5 sometimes have an ARITHMETICAL HIGH JUMP. The teacher makes out 8 sets of problems. The children begin at the bottom of the page. The problems grow harder and harder as you go up the page. You see how far up the page you can go and have every answer correct, the first time. Only 4 pupils in the 5th grade of the Washington School reached the top of the page without making a mistake. See how far up the page you can go.

**Difficulty 8.**

1. Find 5 sixteenths of  $\frac{4}{5}$  of 16.
2. Add 7 twelfths of 1 ft. 6 in. to two thirds of 1 ft. 3 in.
3. What part of  $\frac{2}{3}$  ft. is  $1\frac{1}{3}$  times half an inch?
4. If  $\frac{3}{8}$  lb. cheese cost 12 cents, what will  $\frac{5}{16}$  lb. cheese cost?
5. At the rate of 6 ft. for 5 cents what would be the exact cost of 8 ft. of wire?

**Difficulty 7.**

$2\frac{1}{2} \times 4\frac{4}{5}$      $4\frac{1}{8} \times \frac{5}{6}$      $3\frac{1}{8} + 2\frac{5}{12}$     What part of  $\frac{1}{4}$  is  $\frac{1}{12}$ ?  
 What part of  $3\frac{1}{3}$  is  $\frac{2}{3}$ ?

**Difficulty 6.**

$2\frac{2}{3} + 3\frac{3}{4}$      $\frac{5}{8} \times \frac{11}{5}$      $9\frac{1}{4} - 6\frac{1}{3}$      $\frac{1}{3}$  of  $\frac{3}{16}$      $1\frac{1}{2} \times 3\frac{1}{2}$

**Difficulty 5.**

$7\frac{3}{8} - 5\frac{3}{4}$      $\frac{3}{4} \times \frac{3}{8}$      $\frac{1}{4} \times \frac{1}{2}$      $1\frac{1}{3} + 1\frac{5}{12}$      $2\frac{1}{2} + 1\frac{5}{6}$

**Difficulty 4.**

$3\frac{1}{2} + 4\frac{3}{4}$      $\frac{5}{6} \times 6$      $102 \times 305$      $9\frac{1}{8} - 4\frac{5}{8}$      $21 \times \frac{2}{3}$

**Difficulty 3.**

$9 \overline{)183}$      $\frac{5}{8}$  of 64     $16 - 8\frac{1}{3}$      $70 \times 90$      $\frac{1}{2}$  of  $\frac{1}{4}$

**Difficulty 2.**

$9 \times 8$      $100 \times 27$      $\frac{1}{4}$  of 32     $11 - 8$      $7 \overline{)112}$

**Difficulty 1.**

$3 + 9$      $\frac{1}{2} + \frac{1}{2}$      $10 - 4$      $2 \times 12$      $10 \times 15$

It is useful to be able to tell quickly an approximate result, a result that is near the correct result. Look at these problems. Decide quickly which of the estimates is probably nearest to the exact result. Then find the exact result and see if you chose the nearest estimate.

Problems	Estimates of Correct Answers			
1. $7 \times \$29.68$	a. \$21000	b. \$210.00	c. \$208.00	d. \$195.00
2. $15 \times 36¢$	a. \$37.80	b. \$5.40	c. \$2.16	d. \$5.00
3. $105 \times 120$	a. 12500	b. 1260	c. 1800	d. 126,000
4. $\frac{3}{4} \times 75$	a. 100	b. 50	c. 55	d. $6\frac{1}{4}$
5. $2\frac{1}{2} \times 3\frac{1}{4} \times \frac{3}{4}$	a. 5	b. 10	c. $97\frac{1}{2}$	d. 6
6. $7\frac{1}{2} \times 7\frac{1}{8} \times 7\frac{1}{4}$	a. $5^2\frac{3}{64}$	b. 375	c. 350	d. 8
7. $3\frac{3}{4} \times \$1.60$	a. \$6.00	b. \$60	c. \$5.20	d. \$4.80
8. $25 \overline{) \$28.75}$	a. \$115	b. \$1.00	c. \$1.10	d. \$1.55
9. $25 \overline{) \$77.25}$	a. \$3.10	b. \$.39	c. \$39	d. \$3.00
10. $48 \overline{) 97440}$	a. 2000	b. 200	c. 23	d. 230
11. $18 \overline{) 12600}$	a. 70	b. 80	c. 700	d. 800

## 75.

(Without pencil.)

1. Examine problems 1 to 11 again, stating which estimates you know at once are *not* near the right results. Tell how you know.
2. State how you know —
  - a. That  $\frac{7}{8} \times 5\frac{3}{4}$  cannot be more than 6.
  - b. That  $\frac{5}{8} \times 10$  cannot be less than 5.
  - c. That  $15 \times \$1.23$  cannot be less than \$15.00.
  - d. That  $15 \times \$1.23$  cannot be more than \$30.00.
  - e. That the quotient for  $45 \overline{) 4962}$  must be over 100.
  - f. That the product of  $208 \times 305$  must be over 60,000.
  - g. That the first quotient figure of  $5625 \div 19$  is not 3.



Copy these divisors and dividends, leaving space to perform the divisions. Then look at each and choose the number that you think is probably right for the quotient. Write each quotient, but do not do anything more. Then perform the divisions and see if your quotients were really right. If any one of them was wrong, make it right.

1.	2.	3.	4.	5.
$16 \overline{)155}$	$18 \overline{)155}$	$24 \overline{)155}$	$45 \overline{)155}$	$33 \overline{)155}$
6.	7.	8.	9.	10.
$46 \overline{)410}$	$93 \overline{)410}$	$85 \overline{)410}$	$74 \overline{)410}$	$65 \overline{)410}$
11.	12.	13.	14.	15.
$88 \overline{)575}$	$81 \overline{)575}$	$94 \overline{)575}$	$76 \overline{)575}$	$64 \overline{)575}$
16.	17.	18.	19.	20.
$34 \overline{)296}$	$47 \overline{)296}$	$53 \overline{)296}$	$45 \overline{)296}$	$58 \overline{)296}$

## 77.

Copy these partly completed divisions, leaving space to perform the rest of the work. Then look at each and choose the number that you think is probably right for the second figure of the quotient. Write it in its place, but do not complete the work. Then perform the rest of the work and see if your choice for the second figure in the quotient was really right in each case. If it was wrong, make it right.

1.	2.	3.	4.	5.
$65 \overline{)1750}$ 130 <u>   </u> 450	$94 \overline{)1750}$ 94 <u>   </u> 810	$86 \overline{)1750}$ 172 <u>   </u> 30	$76 \overline{)1750}$ 152 <u>   </u> 230	$63 \overline{)1750}$ 126 <u>   </u> 490
6.	7.	8.	9.	10.
$37 \overline{)3516}$ 333 <u>   </u> 186	$45 \overline{)3516}$ 315 <u>   </u> 366	$54 \overline{)3516}$ 324 <u>   </u> 276	$34 \overline{)3516}$ 34 <u>   </u> 11	$62 \overline{)3516}$ 310 <u>   </u> 416

1. Read, supplying the right numbers where the dots are:

- |   |                               |
|---|-------------------------------|
| A. For 5¢ you can get...balls at 5¢ each.                   | B. $5 \div 5 = \dots$         |
| For 5¢ you can get...apples at $2\frac{1}{2}$ ¢ each.       | $5 \div 2\frac{1}{2} = \dots$ |
| For 5¢ you can get...sticks of candy at 1¢ each.            | $5 \div 1 = \dots$            |
| For 5¢ you can get,..glass marbles at $\frac{1}{2}$ ¢ each. | $5 \div \frac{1}{2} = \dots$  |
| For 5¢ you can get...clay marbles at $\frac{1}{8}$ ¢ each.  | $5 \div \frac{1}{8} = \dots$  |
- 
- |  |                           |
|--|---------------------------|
| C. In 4 in. there are...2-in. lengths.             | D. 3 pies = ...half-pies. |
| In 4 in. there are...1-in. lengths.                | 3 pies = ...quarters.     |
| In 4 in. there are... $\frac{1}{2}$ -in. lengths.  | 3 pies = ...sixths.       |
| In 4 in. there are... $\frac{1}{4}$ -in. lengths.  | E. 7 dimes = ...nickels.  |
| In 4 in. there are... $\frac{1}{8}$ -in. lengths.  | 7 dimes = ...cents.       |
| In 4 in. there are... $\frac{1}{16}$ -in. lengths. |                           |

2. Learn this:

When you divide a number by something more than 1, the result is smaller than the number.

When you divide a number by 1 the result is the same as the number.

When you divide a number by less than 1, the result is larger than the number.

When divisor is more than 1, quotient is smaller than dividend.

When divisor is less than 1, quotient is larger than dividend.

3. Read, supplying the right numbers where the dots are:

- |                                   |                           |                         |
|-----------------------------------|---------------------------|-------------------------|
| A. In 8 there are...4s.           | B. $6 = \dots 3s.$        | C. $12 \div 6 =$        |
| In 8 there are...2s.              | $6 = \dots 2s.$           | $12 \div 4 =$           |
| In 8 there are...1s.              | $6 = \dots 1s.$           | $12 \div 1 =$           |
| In 8 there are... $\frac{1}{2}s.$ | $6 = \dots \frac{1}{2}s.$ | $12 \div \frac{1}{2} =$ |
| In 8 there are... $\frac{1}{4}s.$ | $6 = \dots \frac{1}{3}s.$ | $12 \div \frac{1}{3} =$ |
| In 8 there are... $\frac{1}{8}s.$ | $6 = \dots \frac{1}{4}s.$ | $12 \div \frac{1}{4} =$ |
|                                   | $6 = \dots \frac{1}{5}s.$ |                         |
- 
- |  |                           |
|--|---------------------------|
| D. 2 lb. = ... $\frac{1}{2}$ -lb. weights. | E. $2 \div \frac{1}{2} =$ |
| 2 lb. = ... $\frac{1}{4}$ -lb. weights.    | $2 \div \frac{1}{4} =$    |
| 2 lb. = ... $\frac{1}{8}$ -lb. weights.    | $2 \div \frac{1}{8} =$    |
| 2 lb. = ... $\frac{1}{16}$ -lb. weights.   | $2 \div \frac{1}{16} =$   |

4. Do the work of this page again.

1. Tell the missing quotients:

A.	B.	C.	D.	E.
$1 = \dots \frac{1}{2}S$	$2 \div \frac{1}{2} =$	$3 \div \frac{1}{6} =$	$12 \div \frac{1}{2} =$	$2 = \dots \frac{1}{4}S$
$1 = \dots \frac{1}{3}S$	$2 \div \frac{1}{3} =$	$4 \div \frac{1}{5} =$	$5 \div \frac{1}{3} =$	$4 = \dots \frac{1}{12}S$
$1 = \dots \frac{1}{4}S$	$2 \div \frac{1}{4} =$	$6 \div \frac{1}{3} =$	$9 \div \frac{1}{4} =$	$3 = \dots \frac{1}{12}S$
$1 = \dots \frac{1}{5}S$	$3 \div \frac{1}{2} =$	$2 \div \frac{1}{8} =$	$3 \div \frac{1}{8} =$	$20 = \dots \frac{1}{2}S$
$1 = \dots \frac{1}{6}S$	$3 \div \frac{1}{3} =$	$5 \div \frac{1}{8} =$	$8 \div \frac{1}{2} =$	$5 = \dots \frac{1}{6}S$
$1 = \dots \frac{1}{7}S$	$3 \div \frac{1}{4} =$	$7 \div \frac{1}{2} =$	$6 \div \frac{1}{4} =$	$10 = \dots \frac{1}{3}S$
$1 = \dots \frac{1}{8}S$	$3 \div \frac{1}{8} =$	$10 \div \frac{1}{4} =$	$5 \div \frac{1}{2} =$	$8 = \dots \frac{1}{4}S$

2. Do the work of A, B, C, D, and E again.

3. If 1 lb. or 16 oz. of candy is divided into pieces each weighing  $\frac{1}{2}$  ounce, how many pieces will there be?

4. If the 16 ounces of candy are divided into pieces, each weighing  $\frac{1}{4}$  oz., how many pieces will there be?

5. How many  $\frac{1}{5}$ -oz. pieces will 16 oz. make?

6. 3 yards of ribbon are divided into pieces each  $\frac{1}{8}$  yard long. How many pieces will there be?

$$3 \div \frac{1}{2} = 3 \times 2 \qquad 3 \div \frac{1}{4} = 3 \times 4 \qquad 3 \div \frac{1}{8} = 3 \times 8$$

$$5 \div \frac{1}{2} = 2 \times 5 \qquad 5 \div \frac{1}{4} = 4 \times 5 \qquad 5 \div \frac{1}{8} = 8 \times 5$$

7. See if these are true by dividing a 3-inch length into  $\frac{1}{2}$ -inch lengths, then into  $\frac{1}{4}$ -inch lengths, then into  $\frac{1}{8}$ -inch lengths.

8. See if they are true by dividing 5 dollars into halves and quarters, and by dividing 5 yards into  $\frac{1}{8}$ -yard lengths.

9. Learn this:

2 is the **reciprocal** of  $\frac{1}{2}$ .

3 is the reciprocal of  $\frac{1}{3}$ .

4 is the reciprocal of  $\frac{1}{4}$ .

5 is the reciprocal of  $\frac{1}{5}$ .

**To divide by a fraction multiply by its reciprocal.**

$$\div \frac{1}{8} = \times 8 \qquad \div \frac{1}{12} = \times 12$$

$$\div \frac{1}{4} = 4 \times \qquad \div \frac{1}{3} = 3 \times$$

$$\div \frac{1}{6} = 6 \times \qquad \div \frac{1}{2} = 2 \times$$

1. Compare the result of  $12 \div 3$  with the result of  $12 \times \frac{1}{3}$ .
2. Compare the result of  $16 \div 8$  with the result of  $16 \times \frac{1}{8}$ .
3. Compare the result of  $10 \div 2$  with the result of  $10 \times \frac{1}{2}$ .

$\frac{1}{2}$  is the **reciprocal** of 2.  $\frac{1}{3}$  is the **reciprocal** of 3.

$\frac{1}{12}$  is the **reciprocal** of 12.  $\frac{1}{16}$  is the **reciprocal** of 16.

4. What is the reciprocal of 8? Of 6? Of 4? Of 10?
5. Learn these lines:

$$\div 2 \text{ means } \times \frac{1}{2}. \quad \div 3 \text{ means } \times \frac{1}{3}. \quad \div 4 \text{ means } \times \frac{1}{4}.$$

$$\div 5 \text{ means } \times \frac{1}{5}. \quad \div 6 \text{ means } \times \frac{1}{6}. \quad \div 7 \text{ means } \times \frac{1}{7}.$$

To divide by a number is the same as to multiply by its reciprocal.

Find the quotients. Express the  $\div 4$  or  $\div 5$  or  $\div 6$ , etc., as  $\times \frac{1}{4}$  or  $\times \frac{1}{5}$  or  $\times \frac{1}{6}$ , etc. Cancel when you can.

6.  $\frac{9}{16} \div 3$  Write  $\frac{9}{16} \times \frac{1}{3}$ .  $\frac{3}{16}$  is the correct result.

- |                        |                        |                       |                       |
|------------------------|------------------------|-----------------------|-----------------------|
| 7.                     | 8.                     | 9.                    | 10.                   |
| $\frac{8}{9} \div 4$   | $\frac{3}{8} \div 2$   | $\frac{1}{2} \div 3$  | $\frac{9}{2} \div 3$  |
| 11.                    | 12.                    | 13.                   | 14.                   |
| $\frac{15}{24} \div 5$ | $\frac{1}{3} \div 4$   | $\frac{2}{3} \div 5$  | $\frac{3}{4} \div 3$  |
| 15.                    | 16.                    | 17.                   | 18.                   |
| $\frac{5}{6} \div 7$   | $\frac{16}{5} \div 8$  | $\frac{10}{3} \div 5$ | $\frac{3}{4} \div 9$  |
| 19.                    | 20.                    | 21.                   | 22.                   |
| $1\frac{4}{5} \div 9$  | $6\frac{2}{3} \div 10$ | $4\frac{1}{8} \div 3$ | $1\frac{2}{3} \div 5$ |

Use  $\frac{9}{5}$  for  $1\frac{4}{5}$ . Use  $\frac{20}{3}$  for  $6\frac{2}{3}$ . Use  $\frac{33}{8}$  for  $4\frac{1}{8}$ . Use  $\frac{5}{3}$  for  $1\frac{2}{3}$ .

81. A fraction whose numerator is not less than its denominator is called an **improper fraction**.

1. Express each of these as an improper fraction and divide it by 4:

$$2\frac{1}{2} \quad 3\frac{1}{3} \quad 5\frac{1}{3} \quad 4\frac{4}{5} \quad 1\frac{1}{2} \quad 1\frac{1}{3} \quad 1\frac{1}{8} \quad 2\frac{2}{5} \quad 1\frac{7}{8}$$

2. Express as improper fractions and divide by 6:

$$4\frac{1}{2} \quad 3\frac{3}{4} \quad 5\frac{2}{5} \quad 1\frac{1}{2} \quad 1\frac{1}{3} \quad 1\frac{1}{4} \quad 2\frac{5}{8} \quad 10\frac{1}{2} \quad 4\frac{4}{5}$$



1. Read these lines:

The reciprocal of  $\frac{1}{2}$  is  $\frac{2}{1}$  or 2.

The reciprocal of  $\frac{2}{3}$  is  $\frac{3}{2}$ .

The reciprocal of  $\frac{2}{5}$  is  $\frac{5}{2}$ .

The reciprocal of  $\frac{3}{8}$  is  $\frac{8}{3}$ .

The reciprocal of  $\frac{1}{4}$  is  $\frac{4}{1}$  or 4.

The reciprocal of  $\frac{3}{4}$  is  $\frac{4}{3}$ .

The reciprocal of  $\frac{3}{5}$  is  $\frac{5}{3}$ .

The reciprocal of  $\frac{5}{12}$  is  $\frac{12}{5}$ .

2. Name the reciprocals of:

$\frac{1}{2}$	$\frac{1}{3}$	$\frac{2}{3}$	$\frac{1}{4}$	$\frac{3}{4}$	$\frac{1}{5}$	$\frac{2}{5}$	$\frac{3}{5}$	$\frac{1}{6}$	$\frac{5}{6}$	$\frac{1}{8}$	$\frac{3}{8}$	
$\frac{5}{8}$	$\frac{7}{8}$	2	3	4	$\frac{7}{5}$	5	6	$\frac{3}{2}$	24	$\frac{5}{12}$	$\frac{15}{8}$	$\frac{9}{12}$

Find each quotient. Multiply by the reciprocal. Cancel when you can.

1.

$$32 \div 24$$

Use  $32 \times \frac{1}{24}$ .

2.

$$2\frac{1}{2} \div 2$$

Use  $\frac{5}{2} \times \frac{1}{2}$ .

3.

$$6 \div \frac{1}{3}$$

Use  $6 \times 3$ .

4.

$$3\frac{3}{4} \div \frac{3}{4}$$

Use  $\frac{15}{4} \times \frac{4}{3}$ .

5.

$$3 \div \frac{5}{8}$$

Use  $3 \times \frac{8}{5}$ .

Check your result by multiplying it by  $\frac{5}{8}$ .

6.

$$2\frac{5}{8} \div 1\frac{1}{2}$$

Use  $2\frac{1}{8} \times \frac{2}{3}$ .

Check your result by multiplying it by  $1\frac{1}{2}$ .

7.

$$50 \div 16$$

Use  $50 \times \frac{1}{16}$ .

8.

$$\frac{9}{16} \div \frac{3}{8}$$

Use  $\frac{9}{16} \times \frac{8}{3}$ .

9.

$$\frac{2}{3} \div \frac{2}{9}$$

Use  $\frac{2}{3} \times \frac{9}{2}$ .

10.

$$\frac{5}{6} \div \frac{5}{12}$$

Use  $\frac{5}{6} \times \frac{12}{5}$ .

## 83.

Find each quotient. Multiply by the reciprocal. Cancel when you can. Express mixed numbers as fractions.

1.

$$10 \div 6$$

2.

$$4 \div \frac{2}{3}$$

3.

$$4\frac{1}{8} \div 3$$

4.

$$\frac{8}{5} \div \frac{2}{5}$$

5.

$$2\frac{1}{2} \div \frac{5}{8}$$

6.

$$9 \div 12$$

7.

$$5 \div 25$$

8.

$$\frac{3}{4} \div 3$$

9.

$$100 \div \frac{4}{5}$$

10.

$$\frac{3}{2} \div \frac{5}{6}$$

11.

$$\frac{15}{16} \div \frac{1}{8}$$

12.

$$10\frac{1}{2} \div 1\frac{3}{4}$$

Remember this:

To divide by a number is the same as to multiply by the reciprocal of the number.

## 84. Dividing by a Number Gives the Same Result 55 as Multiplying by Its Reciprocal

*In any problem where you have to divide, you may divide in the usual way with the number as divisor or you may multiply by the reciprocal of the number. Do whichever you can do best.*

*When we divide by a fraction or mixed number, we almost always multiply by the reciprocal because it is easier and quicker. Try both ways with  $3\frac{3}{8} \div \frac{3}{4}$ .*

$$\frac{3}{4} \overline{) 3\frac{3}{8}}$$

$$\frac{27}{8} \times \frac{4}{3}$$

1. How many  $\frac{3}{4}$ -inch lengths are there in  $2\frac{1}{4}$  inches?
2. Check your answer by measuring with your foot rule.
3. How many  $\frac{3}{4}$ -inch lengths are there in  $3\frac{3}{4}$  inches?
4. Check your answer by measuring with your foot rule.
5. How many  $\frac{3}{8}$ -inch lengths are there in  $1\frac{1}{8}$  in.?  
\_\_\_\_\_ =  $\frac{9}{8}$  in.
6. Check your answer by measuring.
7. How many  $\frac{5}{8}$ -in. lengths =  $1\frac{7}{8}$  in.?
8. Check your answer by multiplying  $\frac{5}{8}$  by it.
9. How many gardens, each  $\frac{3}{16}$  acre, can be made from  $1\frac{1}{8}$  acres of land?
10. Check your answer by multiplying  $\frac{3}{16}$  by it.
11. How many times is  $\frac{3}{16}$  sq. in. contained in  $1\frac{5}{16}$  sq. in.?
12. Check your answer by the aid of the picture.
13. A man divided  $5\frac{1}{4}$  acres of land into lots each  $\frac{3}{4}$  A. in size. How many lots did the  $5\frac{1}{4}$  A. make? (A. stands for acre or acres.)
14. How many fields of  $2\frac{1}{4}$  A. each will 18 A. make?
15. What is the cost for one pound of sugar when you get  $3\frac{1}{2}$  lb. for 25 cents?

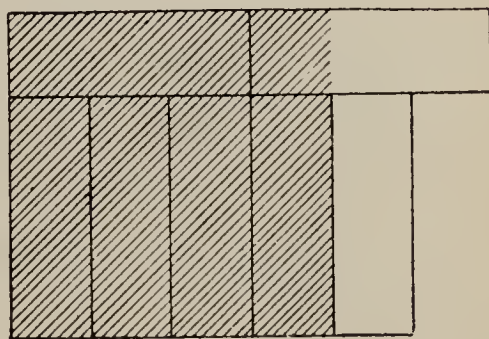

$$\square = \frac{1}{16} \text{ sq. in.}$$

Supply the missing numbers, as is done in the first two. Express all fractions in lowest terms.

A.	B.	C.	D.
$9 = \frac{3}{4}$ of 12	$7 = \frac{1}{3}$ of 21	$23 = \frac{23}{24}$ of 24	$25 = \frac{5}{6}$ of 30
$16 = \frac{2}{3}$ of 24	$8 = \frac{4}{5}$ of 10	$10 = \frac{5}{8}$ of 16	$15 = \frac{1}{10}$ of 150
$2 = \frac{1}{2}$ of ..	$4 = ..$ of 16	$21 = ..$ of 24	$8 = \frac{4}{5}$ of ...
$2 = \frac{1}{3}$ of ..	$4 = ..$ of 8	$11 = ..$ of 12	$8 = \frac{2}{3}$ of ...
$2 = \frac{2}{3}$ of ..	$4 = ..$ of 6	$10 = ..$ of 12	$15 = \frac{3}{4}$ of ...
$3 = \frac{3}{4}$ of ..	$4 = ..$ of 10	$9 = ..$ of 12	$15 = \frac{15}{16}$ of ...
$3 = \frac{1}{2}$ of ..	$4 = ..$ of 5	$8 = ..$ of 12	$15 = \frac{5}{6}$ of ...
$4 = \frac{1}{2}$ of ..	$2 = ..$ of 4	$11 = ..$ of 16	$10 = \frac{2}{3}$ of ...
$9 = \frac{1}{3}$ of ..	$2 = ..$ of 6	$7 = ..$ of 8	$18 = \frac{3}{4}$ of ...
$10 = \frac{2}{3}$ of ..	$5 = ..$ of 15	$6 = ..$ of 18	$18 = \frac{9}{10}$ of ...
$12 = \frac{1}{2}$ of ..	$6 = ..$ of 8	$20 = ..$ of 24	$18 = \frac{1}{2}$ of ...
$12 = \frac{2}{3}$ of ..	$5 = ..$ of 10	$30 = ..$ of 40	$24 = \frac{4}{5}$ of ...
$12 = \frac{3}{4}$ of ..	$10 = ..$ of 15	$22 = ..$ of 24	$24 = \frac{3}{4}$ of ...
$12 = \frac{4}{5}$ of ..	$15 = ..$ of 20	$12 = ..$ of 24	$21 = \frac{7}{8}$ of ...

## 86.

(Do all that you can without pencil.)

Three ladies, Mrs. A., Mrs. B., and Mrs. C., bought some groceries together at wholesale.

- They bought a box of prunes for \$5.00. Mrs. A. paid \$2.00; Mrs. B. paid \$2.00; Mrs. C. paid \$1.00. What part of the prunes should Mrs. A. have? Mrs. B.? Mrs. C.?
- There were 50 lb. prunes. How many pounds should Mrs. A. have? Mrs. B.? Mrs. C.?
- They bought a barrel of potatoes for \$2.40. Mrs. A. paid \$1.20; Mrs. B. paid \$.60; Mrs. C. paid \$.60. What fraction of the potatoes should Mrs. A. have? Mrs. B.? Mrs. C.?

4. They bought 3 doz. packages of shredded wheat. Mrs. A. paid \$1.50; Mrs. B. paid \$1.50; Mrs. C. paid \$1.00. What part of the shredded wheat should Mrs. A. have? Mrs. B.? Mrs. C.?
5. Will they have to break a package to divide the shredded wheat as it should be divided?
6. They bought a box of soap for \$3.60. Mrs. A. paid \$1.80; Mrs. B. paid \$1.20; Mrs. C. paid \$.60. What fraction of the soap should Mrs. A. have? Mrs. B.? Mrs. C.?
7. There were 100 cakes of soap. Will they have to cut some of the cakes?

### 87. Review Problems

(Without pencil.)

1. What part of a foot is 4 inches? What part of a yard is it?
2. How many gallons of oil are required to fill eight  $2\frac{1}{2}$ -gallon cans?
3. The inside dimensions of a box are 2 ft. by 4 ft. by 3 ft. How many cubic feet does it contain?
4. How many rods of fencing are required for a fence around a field  $10\frac{1}{4}$  rods long and  $10\frac{1}{4}$  rods wide?
5. If a train goes  $\frac{2}{3}$  mile per minute how far does it go in 20 minutes?
6. At the rate of  $8\frac{1}{2}$  miles in 15 minutes how far will a train go in half an hour?
7. Helen set out 50 strawberry plants this year. She plans to set out  $2\frac{1}{2}$  times as many next year. How many plants will she need?
8. Will plans to use  $\frac{1}{3}$  of his garden for corn and  $\frac{1}{4}$  of it for peas. How much will be left for other things?



9. His garden is 45 ft. long and 25 ft. wide. How many feet of fence will be required to inclose it?
10. What part of a yard is 9 inches? What part of a foot is it?
11. Using  $1\frac{1}{2}$  bushels of wheat per acre, how many bushels will be required to sow 16 acres?
12. An 8-acre field was divided into 20 equal plots. What part of an acre was the area of each plot?
13. Check your answer to No. 12 in this way:  
 *$20 \times$  Answer should be 8 acres.*

## 88.

Divide each of these numbers by 32:

1.	2.	3.	4.	5.	6.	7.
650	1000	1728	640	2956	3748	32,000

Check each quotient by multiplying it by the divisor and adding the remainder to the product.

Divide each of these numbers by 75. If your work is correct there will be no remainders.

8.	9.	10.	11.	12.	13.	14.
1575	2850	3675	5100	6000	72,000	8625

## 89.

*(With pencil.)*

1. Which is larger,  $\frac{9}{16}$  or  $\frac{5}{8}$ ? How much larger?
2. Which is larger,  $\frac{5}{12}$  or  $\frac{3}{8}$ ? How much larger?
3. How many cubic inches are there in 1 cubic foot?
4. A rod is  $5\frac{1}{2}$  yd. long. How many sq. yd. are there in 1 sq. rd.?
5. A rod equals  $16\frac{1}{2}$  ft. How many sq. ft. are there in one sq. rd.?
6. How many  $\frac{7}{8}$ -in. lengths can be cut from 42 inches of wire?

7. How many cubic feet does a box contain if its inside dimensions are  $3\frac{1}{2}$  ft. by  $2\frac{1}{2}$  ft. by  $1\frac{3}{4}$  ft.?
8. How many pupils can work at a blackboard  $15\frac{3}{4}$  ft. long, if each pupil is given a space 27 inches long?
9. What length of wire netting is needed to inclose a pen  $7\frac{1}{2}$  ft. by  $7\frac{1}{2}$  ft.?
10. One towel requires  $\frac{7}{8}$  yd. Will 10 yd. be enough for a dozen towels?
11. At the rate of  $\frac{1}{12}$  mile per minute, how far does a man walk in 30 min.?
12. At the rate of  $\frac{2}{5}$  mile per minute, how far does a train go in half an hour?
13. At the rate of  $1\frac{7}{8}$  miles per minute, how far does an airplane go in half an hour?
14. At the rate of  $1\frac{7}{8}$  miles per minute how long will it take an airplane to go  $10\frac{1}{2}$  miles?
15. At the rate of 18 miles an hour, how far will an automobile go from 1:45 P.M. to 5 P.M.?
16. At the rate of 20 miles an hour, what part of a 100-mile trip will be done in  $2\frac{1}{2}$  hours?

## 90.

State the missing numbers:

A.	B.	C.	D.	E.
$\frac{3}{4} + \frac{1}{2} =$	$8 - \frac{1}{4} =$	$12 \div 6 =$	$6 = \dots$ of 12	$30 = \frac{3}{4}$ of ..
$\frac{3}{4} - \frac{1}{2} =$	$8 \times \frac{1}{4} =$	$12 \div 4 =$	$5 = \dots$ of 12	$30 = \frac{2}{3}$ of ..
$\frac{3}{4} \times \frac{1}{2} =$	$8 \div \frac{1}{4} =$	$12 \div 3 =$	$4 = \dots$ of 12	$30 = \frac{5}{6}$ of ..
$\frac{3}{4} \div \frac{1}{2} =$	$8 \times 2\frac{1}{2} =$	$12 \div 2 =$	$3 = \dots$ of 12	$10 \div 8 =$
$\frac{3}{8} + \frac{3}{8} =$	$\frac{7}{8}$ of 16 =	$12 \div 1 =$	$10 = \dots$ of 12	$10 \div 16 =$
$\frac{1\frac{1}{2}}{1\frac{1}{2}} - \frac{5}{1\frac{1}{2}} =$	$\frac{7}{8}$ of 8 =	$12 \div \frac{1}{2} =$	$9 = \dots$ of 12	$12 \div 15 =$
$\frac{5}{6} \times 2 =$	$\frac{7}{8}$ of 4 =	$12 \div \frac{1}{3} =$	$8 = \dots$ of 12	$12 \div 30 =$
$5 \times \frac{6}{5} =$	$\frac{7}{8}$ of 2 =	$12 \div \frac{1}{4} =$	$8 = \dots$ of 20	$25 \div 40 =$

(Without pencil.)

1. In November we expect one third of the days to be rainy or cloudy. What part of the days do we expect to be clear?
2. If 25 out of 30 days in this November are clear, how many more will that be than we expect?
3. How many months are there in half a year? In  $2\frac{1}{2}$  years? In  $\frac{3}{4}$  yr.?
4. How many weeks are there in 1 yr.? In  $\frac{1}{4}$  yr.? In  $\frac{3}{4}$  yr.?
5. At the rate of 20 miles an hour, how far will an automobile go from 1:45 P.M. to 2:15 P.M.?
6. How many cubic feet does a box  $2' \times 5' \times 2'$  occupy?
7. In going to school Helen walks  $\frac{1}{4}$  mile, then takes a trolley for  $2\frac{1}{2}$  miles, and then walks  $\frac{1}{4}$  mile more. What is the total distance?
8. If  $\frac{1}{8}$  inch on a map represents 1 mile, what length will represent 9 miles?
9. What length will represent 7 miles? 5 miles?

## 92.

Find the products for 2, 3, 4, 5, 6, and 7 as is done in 1.

$$\begin{array}{r}
 1. \ \$1.75 \\
 \underline{21\frac{3}{4}} \\
 175 \\
 350 \\
 \hline
 3675 \\
 131\frac{1}{4} \\
 \hline
 \$38.06\frac{1}{4}
 \end{array}$$

Find the product of  $21 \times \$1.75$ . Then find  $\frac{3}{4} \times \$1.75$  and add it to the product. Put \$ and . where they belong.

$$\frac{3}{4} \times 175 = \frac{525}{4}$$

$$\begin{array}{r}
 131\frac{1}{4} \\
 4 \overline{)525}
 \end{array}$$

2.	3.	4.
\$2.35	\$1.15	\$.86
<u>13<math>\frac{3}{4}</math></u>	<u>32<math>\frac{1}{2}</math></u>	<u>14<math>\frac{3}{4}</math></u>
5.	6.	7.
\$1.45	\$1.04	\$2.15
<u>56<math>\frac{1}{2}</math></u>	<u>35<math>\frac{3}{4}</math></u>	<u>.23<math>\frac{1}{4}</math></u>

8. At \$1.25 a gallon, find the cost of  $8\frac{1}{2}$  gallons of ice cream.
9. Find the cost of  $5\frac{1}{2}$  gallons.
10. Of 15 gallons.

Fowl is 22¢ a pound.

Chicken is 28¢ a pound.

Duck is 25¢ a pound.

Turkey is 33¢ a pound.

Find the cost of

$4\frac{5}{8}$  lb. duck.

$4$  lb. cost  $4 \times 25¢$ .

\$1.00

$\frac{5}{8}$  lb. cost  $\frac{5}{8} \times 25¢$ .

$\frac{15\frac{5}{8}}{8}$  .16

$\frac{15\frac{5}{8}}{8}$  \$1.16

$\frac{1}{2}$  cent or more counts as 1 cent. Less than  $\frac{1}{2}$  cent counts as 0 cents.

Find the cost of

$7\frac{3}{4}$  lb. chicken.

$7$  lb. cost  $7 \times 28¢$ .

\$ .28

$\frac{7}{8}$

\$1.96

$\frac{3}{4}$  lb. cost  $\frac{3}{4} \times 28¢$ .

.21

\$2.17

Find the cost of each of these purchases:

- |                                 |                                |                                |
|---------------------------------|--------------------------------|--------------------------------|
| 1. $5\frac{3}{8}$ lb. fowl.     | 2. $8\frac{3}{4}$ lb. duck.    | 3. $4\frac{3}{8}$ lb. chicken. |
| 4. $12\frac{5}{8}$ lb. turkey.  | 5. $9\frac{1}{8}$ lb. fowl.    | 6. $7\frac{7}{8}$ lb. duck.    |
| 7. $3\frac{9}{16}$ lb. chicken. | 8. $17\frac{3}{4}$ lb. turkey. | 9. $15\frac{1}{4}$ lb. turkey. |

*When you can tell what the cost is more easily without writing the numbers and multiplying, you need not write them.*

Find the cost of each of these purchases:

- |                                 |                                 |                                 |
|---------------------------------|---------------------------------|---------------------------------|
| 10. $5\frac{1}{2}$ lb. fowl.    | 11. $9\frac{3}{8}$ lb. fowl.    | 12. $10\frac{1}{2}$ lb. duck.   |
| 13. $4\frac{1}{4}$ lb. chicken. | 14. $5\frac{1}{2}$ lb. chicken. | 15. $9\frac{3}{8}$ lb. chicken. |
| 16. $9\frac{3}{8}$ lb. turkey.  | 17. 6 lb. fowl.                 | 18. $3\frac{3}{4}$ lb. chicken. |

### 94. Vacation Trips

- On their canoeing trip George and Fred carried a tent weighing  $6\frac{7}{8}$  lb., blankets weighing  $11\frac{1}{2}$  lb., a stove weighing  $9\frac{1}{4}$  lb., and other supplies weighing 35 lb. What was the total weight?
- 1 lb. sugar takes up  $27\frac{1}{2}$  cu. in. The boys filled a can whose inside dimensions are  $4\frac{1}{2}'' \times 4\frac{1}{2}'' \times 5\frac{1}{2}''$ . How many pounds of sugar did the can hold?



3. They had to carry their canoe overland at three places. One stretch or portage was  $\frac{3}{8}$  mile. One was  $\frac{1}{4}$  mile. One was  $\frac{1}{8}$  mile. How far did they carry it in all?
4. The largest fish George caught weighed  $4\frac{1}{16}$  lb. The largest one Fred caught weighed  $3\frac{15}{16}$  lb. How much heavier was George's fish?
5. On a walking trip Alice and Mary walked  $9\frac{1}{2}$  mi. the first day,  $10\frac{1}{4}$  the second, and  $10\frac{3}{4}$  the third. How far did they go in the three days?
6. How far must they walk the fourth day to make an average of 10 miles a day for the four days?
7. It is  $4\frac{1}{8}$  miles from Ferry Camp to the top of Bear Mountain. The trip to Fox Lodge is said to be  $2\frac{1}{2}$  times as long. If this is correct, how long is the trip to Fox Lodge?

## 95.

1. What is the cost of  $\frac{3}{4}$  lb. butter at 40¢ per lb. and  $\frac{1}{4}$  lb. tea at 60¢ per lb.?
2. Allowing  $\frac{1}{4}$  lb. meat as a one-day ration, how many one-day rations of meat will 2500 lb. make?
3. If you get  $\frac{5}{8}$  lb. butter for 15 cents, how much would you have to pay for a pound? For  $\frac{3}{4}$  lb.?
4. Dick plans to spend  $\frac{3}{10}$  of what he earns in the summer for clothes and books,  $\frac{2}{10}$  for games and tools, and put the rest in the bank. What fraction of his money does he plan to put in the bank?
5. On Saturday Fred did two jobs, each requiring three quarters of an hour. Will worked at one job for  $1\frac{1}{4}$  hr. Which boy worked longer? How much longer?
6. At 10¢ per hour, how much did Fred earn?

1. How many cubic yards of concrete are there in a concrete sidewalk 6 ft. wide, 90 ft. long, and 8 in. deep?
2. How many cubic inches of gasoline are there in a tank 18 inches long and 15 inches wide when it is filled to a depth of 4 inches?
3. It takes  $\frac{1}{5}$  bushel clover seed to sow one acre. How much is needed for  $4\frac{1}{2}$  acres?
4. Mr. Roberts has 9 bushels of wheat.  $1\frac{1}{2}$  bushels are required to sow one acre. How many acres will the 9 bushels provide for?
5. How much more seed must Mr. Roberts get to have enough for 10 acres?
6. Laura's room was  $8\frac{1}{2}$  ft. wide and 12 ft. long. She covered the floor, using four pieces of straw matting that used to be in the living-room. They were all 1 yard wide. One was 9 ft. long; one was  $10\frac{1}{2}$  ft. long; the third was  $9\frac{3}{4}$  ft. long; the fourth was  $9\frac{1}{4}$  ft. long. How much could Laura cut off from the first piece and still have it long enough? How much could she cut off from the second piece? From the third piece? From the fourth piece?
7. Can you cut 4 shelves, each  $2\frac{1}{2}$  ft. long, from a board 11 ft. long? Will there be any of the board left over?
8. Helen made a blanket for her baby sister. She bought  $1\frac{1}{4}$  yd. cloth at 80¢ per yard and  $4\frac{5}{8}$  yd. ribbon at 16¢ per yard. How much did the material cost?
9. Margaret reckons that 5¢ worth of meat lasts her dog 2 days, and that 25¢ worth of dog biscuit lasts him 12 days. If this is correct, how much does it cost for the dog's meat and dog biscuit per day?
10. What does it cost per week for oats for a horse that eats 12 qt. per day, if oats cost 50¢ per bushel?

## 97. Review

1. Name four improper fractions.
2. Name four fractions which might be called "proper" fractions or "ordinary" fractions.
3. Name four integers. 4. Name four mixed numbers.
5. What is the difference between improper fractions and mixed numbers?
6. Name ten numbers that are divisible by 5 without remainder.
7. Name ten numbers that are divisible by 3 without remainder.
8. Name the even numbers from 20 to 40.
9. Name the odd numbers from 15 to 35.
10. Name four prime numbers. 11. Name the prime numbers from 5 to 19.
12. Name three fractions each having 5 as denominator.
13. Name three fractions each having 5 as numerator.
14. Name three fractions that are not in lowest terms. Then express each of them in lowest terms.
15. State the reciprocals of:  
 $\frac{2}{3}, \frac{1}{4}, \frac{5}{3}, 3, 7, \frac{5}{8}, \frac{2}{9}, \frac{1}{6}, \frac{5}{12}, \frac{3}{2}, \frac{15}{8}, \frac{11}{12}, \frac{7}{11}.$

## 98.

Copy and reduce to lowest terms. (If the fraction is in lowest terms, write l. t. after it.)

1.	2.	3.	4.	5.	6.	7.	8.
$\frac{48}{64}$	$\frac{15}{25}$	$\frac{13}{16}$	$\frac{18}{24}$	$\frac{20}{32}$	$\frac{11}{27}$	$\frac{15}{12}$	$\frac{16}{12}$
9.	10.	11.	12.	13.	14.	15.	16.
$\frac{15}{27}$	$\frac{14}{8}$	$\frac{10}{8}$	$\frac{11}{3}$	$\frac{12}{4}$	$\frac{12}{6}$	$\frac{8}{6}$	$\frac{16}{24}$
17.	18.	19.	20.	21.	22.	23.	24.
$\frac{2}{12}$	$\frac{5}{10}$	$\frac{25}{100}$	$\frac{40}{100}$	$\frac{18}{20}$	$\frac{21}{30}$	$\frac{16}{40}$	$\frac{10}{12}$

Sometimes we use fractions with very large denominators like

$$\frac{5}{32} \quad \frac{11}{64} \quad \frac{7}{50} \quad \frac{19}{100} \quad \frac{37}{1000}$$

These four rectangles are  $\frac{1}{10}$  sq. ft.,  $\frac{1}{50}$  sq. ft.,  $\frac{1}{100}$  sq. ft. and  $\frac{1}{1000}$  sq. ft.

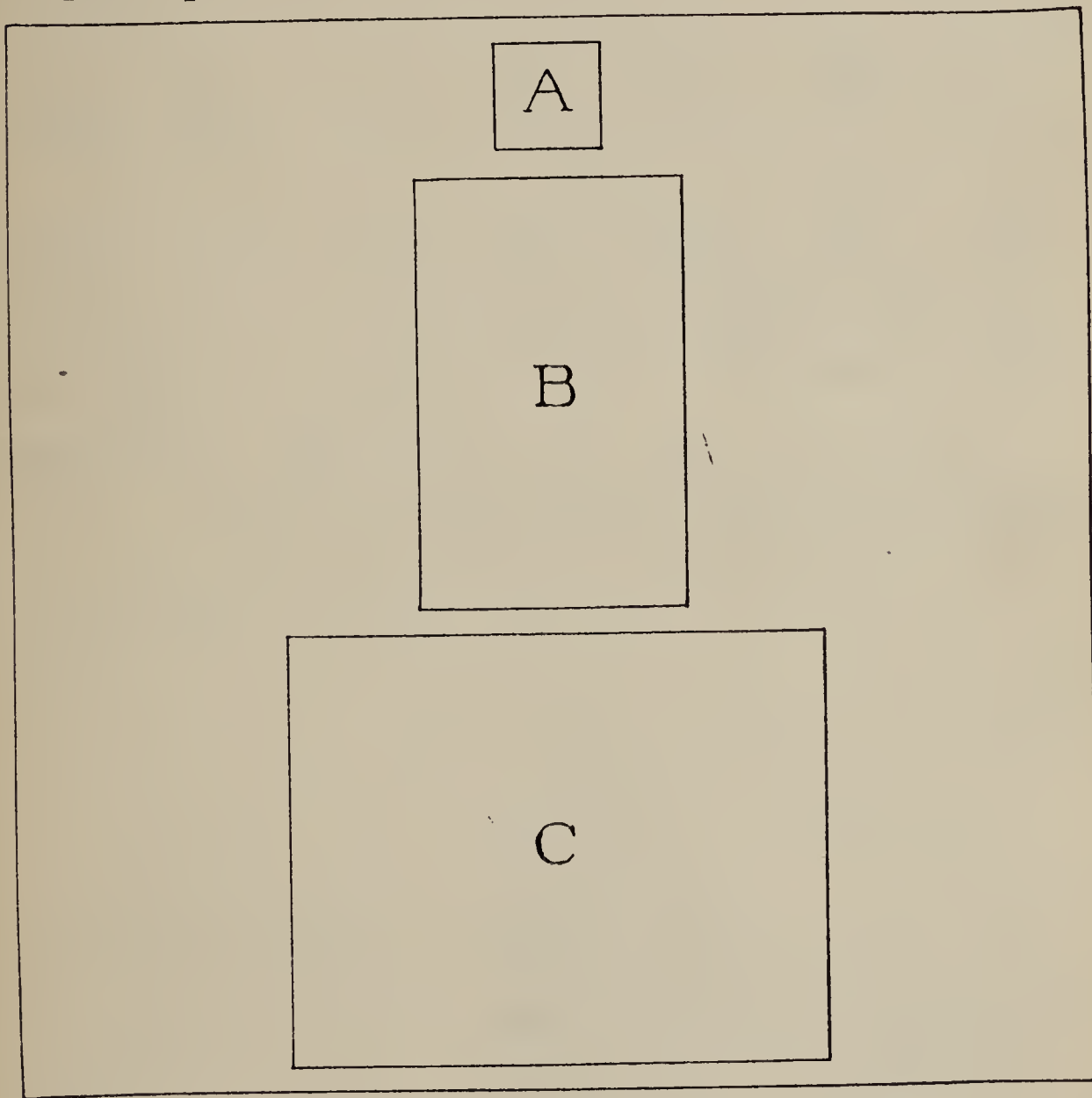

D

1. Which is  $\frac{1}{10}$  sq. ft.?
2. Which is  $\frac{1}{50}$  sq. ft.?
3. Which is  $\frac{1}{100}$  sq. ft.?
4. Which is  $\frac{1}{1000}$  sq. ft.?

We read  $\frac{8}{100}$  as "eight hundredths." We read  $\frac{6}{1000}$  as "six thousandths."



66 100. Fractions with 10, 100, or 1000 as Denominators

1 mile equals 5280 ft.

- How many feet =  $\frac{1}{8}$  mile?  $\frac{1}{10}$  mile?  $\frac{1}{32}$  mile?  $\frac{1}{100}$  mile?
- Is  $\frac{1}{1000}$  mile about  $\frac{1}{2}$  ft. or  $5 \frac{28}{100}$  ft. or  $52 \frac{8}{100}$  ft.?
- Reduce these fractions and mixed numbers to lowest terms:

Row A.

1.	2.	3.	4.	5.	6.	7.
$\frac{32}{64}$	$\frac{250}{1000}$	$\frac{50}{100}$	$2 \frac{25}{100}$	$\frac{75}{100}$	$\frac{800}{1000}$	$\frac{125}{1000}$

Row B.

8.	9.	10.	11.	12.	13.	14.
$\frac{25}{50}$	$2 \frac{8}{10}$	$\frac{375}{1000}$	$\frac{30}{100}$	$\frac{50}{100}$	$\frac{8}{32}$	$\frac{70}{100}$

- Write the missing numerators:

$$\frac{500}{1000} = \frac{\quad}{100} \text{ Or } \frac{\quad}{10}. \quad \frac{700}{1000} = \frac{\quad}{100} \text{ Or } \frac{\quad}{10}. \quad \frac{650}{1000} = \frac{\quad}{100}.$$

$$\frac{1}{2} = \frac{\quad}{10} \text{ Or } \frac{\quad}{100} \text{ Or } \frac{\quad}{1000}. \quad \frac{3}{4} = \frac{\quad}{100} \text{ Or } \frac{\quad}{1000}. \quad \frac{17}{100} = \frac{\quad}{1000}.$$

- How many seconds are there in one minute?
- How many seconds are there in one hour?
- In 10 hours? 8. In  $\frac{1}{10}$  hour? 9. In  $\frac{1}{100}$  hour?

101.

- Say the missing numbers:

$$\frac{1}{10} \text{ of } 20 = \frac{1}{100} \text{ of } 1000 = \frac{1}{10} \text{ of } 6000 =$$

$$\frac{1}{10} \text{ of } 80 = \frac{1}{100} \text{ of } 2000 = \frac{1}{100} \text{ of } 6000 =$$

$$\frac{1}{10} \text{ of } 100 = \frac{1}{100} \text{ of } 5000 = \frac{1}{1000} \text{ of } 6000 =$$

$$\frac{1}{10} \text{ of } 500 = \frac{1}{1000} \text{ of } 2000 = 4 = \dots \text{ of } 40$$

$$\frac{1}{10} \text{ of } 1000 = \frac{1}{1000} \text{ of } 5000 = 4 = \dots \text{ of } 400$$

$$\frac{1}{10} \text{ of } 2000 = \frac{1}{1000} \text{ of } 1000 = 4 = \dots \text{ of } 4000$$

$$\frac{1}{10} \text{ of } 5000 = \frac{1}{100} \text{ of } 100 = 8 = \dots \text{ of } 800$$

- Tell the sums:

$\frac{4}{10}$	$\frac{3}{32}$	$\frac{3}{100}$	$\frac{3}{10}$	$\frac{7}{1000}$	$\frac{3}{64}$	$\frac{3}{100}$
$\frac{1}{10}$	$\frac{5}{32}$	$\frac{3}{100}$	$\frac{1}{10}$	$\frac{4}{1000}$	$\frac{1}{64}$	$\frac{5}{100}$
<u><math>\frac{2}{10}</math></u>	<u><math>\frac{1}{32}</math></u>	<u><math>\frac{7}{100}</math></u>	<u><math>\frac{4}{10}</math></u>	<u><math>\frac{6}{1000}</math></u>	<u><math>\frac{3}{64}</math></u>	<u><math>\frac{2}{100}</math></u>

1. What part of a dollar is a dime?
2. What part of a dollar is a cent?
3. Copy this: \$8425.48. Write "1000s" over the digit that counts as eight thousand dollars. Write "100s" over the digit that counts as hundreds of dollars. Write "10s" over the digit that counts as tens of dollars. Write "1s" or "units" over the digit that counts as dollars. Write  $\frac{1}{10}$ s over the digit that counts as tenths of a dollar. Write  $\frac{1}{100}$ s over the digit that counts as hundredths of a dollar.
4. Write the number that means 7 dollars, 4 tenths of a dollar, and 5 hundredths of a dollar.
5. Write the number that means 2 dollars,  $\frac{6}{10}$  of a dollar, and  $\frac{8}{100}$  of a dollar.
6. Write the number that means  $\frac{48}{100}$  of a dollar.
7. Do you think 25.48 mi. means more than 2000 miles or about  $25\frac{1}{2}$  miles?
8. What part of a mile is 528 ft.?
9. Which of these numbers do you think means the same as  $1\frac{1}{4}$  miles? Which equals  $6\frac{3}{4}$  miles? Which equals a little more than 8 miles?

6.75 mi.      1.25 mi.      8.08 mi.

10. What do you think 2.48 tons means?
11. Divide 2000 by 10. How many pounds = .1 ton?
12. Divide 2000 by 100. How many pounds = .01 ton?
13. Copy these lines, supplying the missing numbers:

100 tons = ... pounds	.01 mile = 52.8 ft.
10 tons = ... pounds	.1 mile = ... ft.
1 ton = ... pounds	1 mile = ... ft.
.1 ton = ... pounds	10 miles = ... ft.
.01 ton = ... pounds	100 miles = ... ft.

## 103. Measuring Distance with a Cyclometer

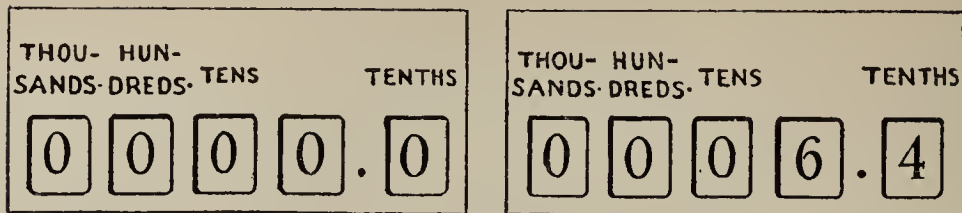

The left-hand picture shows Fred's cyclometer when he bought it. The right-hand picture shows Fred's cyclometer after he had put it on his bicycle and ridden 6.4 mi. (or  $6\frac{4}{10}$  mi.).

1. How will the cyclometer look after he rides 2.3 mi. ( $2\frac{3}{10}$  miles) more?
2. How does Fred tell how far he goes in one day or one trip?
3. If the cyclometer reads 0071.2 at 9 A.M. and 0084.9 at 11 A.M., how many miles has the bicycle covered in the two hours?
4. If the cyclometer reads 0112.3 when Fred leaves home and 0127.6 when he reaches his uncle's farm, how many miles has the bicycle gone on that trip?
5. How does the cyclometer show half a mile?
6. How does the cyclometer show two tenths of a mile?  
We may write  $\frac{1}{10}$  as .1;  $\frac{2}{10}$  as .2;  $\frac{3}{10}$  as .3 .
7. Write "eight and nine tenths inches," using only two figures.
8. Write "six and four tenths miles," using only two figures.
9. Write "nine and five tenths pounds," using only two figures.
10. Fred rode 11.3 miles Monday, 12 miles Tuesday, 6.4 miles Wednesday, and 40.1 miles during the rest of the week. How many miles did he ride in the whole week?

Write the sums:

1.	2.	3.	4.	5.	6.	7.	8.
9.2	5.2	9	7.5	16.9	14.8	8.5	9
16.1	8	15.9	13.6	15.2	7	9	7.9
8.5	13.4	7	9	9.7	15	15.7	15
<u>15.4</u>	<u>19.3</u>	<u>14.7</u>	<u>8.8</u>	<u>18</u>	<u>6.8</u>	<u>6.8</u>	<u>18.4</u>

*On Monday, July 3, Helen's cyclometer indicated 0163.4.*

*On Monday, July 10, Helen's cyclometer indicated 0187.8.*

*On Monday, July 17, Helen's cyclometer indicated 0223.5.*

*On Monday, July 24, Helen's cyclometer indicated 0238.1.*

*On Monday, July 31, Helen's cyclometer indicated 0261.0.*

*On Monday, August 7, Helen's cyclometer indicated 0285.7.*

9. Find out how many miles the bicycle had gone during the week of July 3 to July 10.
10. During the week July 10 to July 17.
11. During the week July 17 to 24.
12. From July 24 to July 31.
13. From July 31 to Aug. 7.

## 105.

The value of a figure or the amount represented by a figure depends upon the position or place it occupies.

7 in 6725.4 mi. represents 700 miles.

7 in 3872.6 mi. represents 70 miles.

7 in 5217.45 mi. represents 7 miles.

7 in 4963.7 mi. represents 7 tenths of a mile.

7 in 2865.47 mi. represents 7 hundredths of a mile.

We speak of **thousands place**, **hundreds place**, **tens place**, **units place**, **tenths place**, and **hundredths place**.

1. Tell which place 4 is in and how many miles it means, or counts as, or represents, in each of these numbers:  
 3246.85            8462.53            2583.46            5328.64
2. State the same facts about 2. About 3. About 5.



1. Read these numbers:

40.1 miles 40.1 seconds 40.1 pounds

8.7 inches 8.7 feet 8.7 minutes

.6 miles or .6 of a mile. .6 inch or .6 of an inch.

.3 hr. .1 hr. .7 hr. .4 yd. .8 acre.

2. Write, using a decimal point:

Twelve and three tenths. Thirty and eight tenths.

Nine and two tenths. Twenty-five and one tenth.

 $\frac{3}{10}$   $\frac{7}{10}$   $\frac{1}{10}$   $\frac{9}{10}$   $6\frac{3}{10}$   $4\frac{7}{10}$   $8\frac{5}{10}$   $\frac{4}{10}$ 

3. Tell how many minutes there are in:

 $\frac{1}{4}$  hr.  $\frac{1}{5}$  hr.  $\frac{2}{5}$  hr.  $\frac{4}{5}$  hr.  $\frac{1}{10}$  hr.  $\frac{3}{10}$  hr.  $\frac{7}{10}$  hr.

.1 hr. .2 hr. .6 hr. .3 hr. .5 hr.

4. Supply the missing numbers:

1 mile = 5280 ft. .1 mile = ... ft.

1 A. (acre) = 160 sq. rd. .1 A. = ... sq. rd.

1 sq. mi. = 640 A. .1 sq. mi. = ... A.

5. Tell how many miles there are in:

 $\frac{1}{2}$  of 40 mi.  $\frac{1}{5}$  of 40 mi. .1 of 40 mi. .3 of 40 mi..8 of 40 mi.  $\frac{1}{5} \times 30$  mi. .1 of 30 mi.  $.4 \times 30$  mi..5 of 30 mi.  $.2 \times 30$  mi.

6. How much is .1 of 40? .1 of 30? .1 of 60?
- $.1 \times 20$
- ?

 $.1 \times 10$ ?

7. How much is
- $.3 \times 20$
- ?
- $.3 \times 50$
- ?
- $.3 \times 30$
- ?
- $.3 \times 10$
- ?

 $.3 \times 70$ ?

8. How much is
- $.7 \times 10$
- ?
- $.7 \times 20$
- ?
- $.7 \times 30$
- ?
- $.7 \times 40$
- ?

 $.7 \times 50$ ?

9. We write
- $\frac{1}{10}$
- as .1;
- $\frac{2}{10}$
- as .2;
- $\frac{3}{10}$
- as .3, etc.

We write  $\frac{1}{100}$  as .01;  $\frac{2}{100}$  as .02;  $\frac{3}{100}$  as .03, etc.

Write these numbers, using a decimal point:

 $\frac{7}{100}$   $\frac{9}{10}$   $\frac{3}{100}$   $\frac{8}{100}$   $\frac{4}{10}$   $\frac{5}{10}$   $\frac{5}{100}$   $\frac{6}{10}$   $\frac{6}{100}$   $\frac{2}{10}$ We write  $\frac{48}{100}$  as .48;  $\frac{23}{100}$  as .23;  $\frac{17}{100}$  as .17;  $\frac{60}{100}$  as .60.

Miles		Hr.	Min.
0	Lv. New York.....	5	34
7.10	“ High Bridge.....	5	52
8.06	“ Morris Heights.....	5	55
8.73	“ University Heights.....	5	57
9.64	“ Marble Hill.....	6	00
12.24	“ Riverdale.....	6	08
13.68	“ Ludlow.....	6	11
14.49	“ Yonkers.....	6	18
15.58	“ Glenwood.....	6	21
17.19	“ Greystone.....	6	24
18.75	“ Hastings.....	6	30
20.00	“ Dobb’s Ferry.....	6	35
21.03	“ Ardsley.....	6	37
21.98	“ Irvington.....	6	42
24.52	“ Tarrytown.....	6	48

1. Read this time table, saying:

“From New York to High Bridge is seven and ten hundredths miles. From New York to Morris Heights is eight and six hundredths miles. From New York to University Heights is eight and seventy-three hundredths miles,” and so on.

2. Which station is about 22 miles from New York?
3. Which station is almost exactly  $14\frac{1}{2}$  miles from New York?
4. Which station is exactly  $18\frac{3}{4}$  miles from New York?
5. Which station is almost exactly twice as far from New York as Riverdale is?

Find the distance between—

6. Morris Heights and Marble Hill.
7. Marble Hill and Riverdale.
8. Riverdale and Ludlow.
9. Ludlow and Yonkers.
10. Yonkers and Glenwood.
11. Glenwood and Greystone.
12. Greystone and Hastings.
13. Hastings and Dobb’s Ferry.
14. Dobb’s Ferry and Ardsley.
15. Ardsley and Irvington.
16. Irvington and Tarrytown.

Remember to put the decimal point where it belongs to show which numbers mean miles and which numbers mean hundredths of a mile.

17. If a train goes at the rate of .75 mi. per minute how far will it go in an hour?

$$\begin{array}{r} .75 \\ \times 60 \\ \hline \end{array} \quad 0 \times .75 = 0. \quad \text{Write } 0.$$

$$\begin{array}{r} 60 \\ \times 5 \\ \hline \end{array} \quad 6 \times 5 = 30. \quad \text{Write } 0. \quad \text{Remember the } 3.$$

$$\begin{array}{r} 45.00 \\ \times 6 \\ \hline \end{array} \quad 6 \times 7 = 42. \quad 42 + 3 = 45.$$

*Put a decimal point in the product where it belongs to show which numbers mean miles and which numbers mean hundredths of a mile.*

18. How far will a train go in an hour at the rate of .68 mi. per minute?
19. At the rate of .81 mi. per minute?    20. At the rate of .37 mi. per minute?

### 108. Tenths and Hundredths

1. Supply the missing numbers where the dots are:

$$\frac{1}{10} = .1 \quad \frac{6}{10} = .6 \quad . \text{ shows that the } 1 \text{ and } 6 \text{ mean...}$$

$$\frac{1}{100} = .01 \quad \frac{6}{100} = .06 \quad .0 \text{ shows that the } 1 \text{ and } 6 \text{ mean...}$$

$$\frac{1}{1000} = .001 \quad \frac{6}{1000} = .006 \quad .00 \text{ shows that the } 1 \text{ and } 6 \text{ mean...}$$

2. Which of these is equal to .1 mile?    3. Which is equal to .01 mile?    4. Which is equal to .001 mile?

$$528 \text{ ft.} \quad 52.8 \text{ ft.} \quad 5.28 \text{ ft.}$$

5. What part of a dollar is one cent?
6. How many cents = seven hundredths of a dollar (\$.07)?
7. 10 mills make one cent. How many mills make one dollar?
8. What part of a dollar is one mill?
9. How many mills equal four thousandths of a dollar (\$.004)?

Numbers like .1, .01, .001, .6, .06, .006, .8, .28, .004 are called decimal fractions, or simply decimals.

Numbers like 16.24, 9.05, 1.3, 2.7, 4.81 are called decimal mixed numbers or simply decimals.

We read .74 mile, "seventy-four hundredths of a mile."

We read 25.38 miles, "twenty-five and thirty-eight hundredths miles."

We read 15.07 miles, "fifteen and seven hundredths miles."

1. Read these numbers:

- a. 16.51 mi.   b. 9.08 mi.   c. 17.06 mi.   d. 1.63 in.  
 e. .27 mi.   f. .64 ft.   g. .1 ft.   h. .01 ft.   i. .001 ft.  
 j. .8 ft.   k. .08 ft.   l. .008 ft.   m. 7.03 mi.   n. 7.3 mi.  
 o. .73 mi.   p. 730 mi.   q. 7.003 mi.

one ten = 10

one tenth = .1 or  $\frac{1}{10}$

one hundred = 100

one hundredth = .01 or  $\frac{1}{100}$

one thousand = 1000

one thousandth = .001 or  $\frac{1}{1000}$

two tens = 20

two tenths = .2

two hundred = 200

two hundredths = .02

two thousand = 2000

two thousandths = .002

2. Write in figures:

- a. Thirty-two hundredths.   b. Nine hundredths.  
 c. Five thousand seventy-four.  
 d. Eight thousandths.   e. Sixteen hundred twenty-nine.  
 f. Sixteen and twenty-nine hundredths.

### 110.

1. What part of a mile = 528 ft.?
2. Is .001 mi. equal to .528 ft. or 5.28 or 52.8 ft.?
3. Do 528 ft. = .1 mi. or .01 mi. or .001 mi.?
4. Does 1.76 yd. equal .1 mi. or .01 mi. or .001 mi. or .0001 mi.?
5. What part of a mile = 17.6 yd.?
6. Is 1 inch about .3 yd., or about .03 yd., or about .003 yd.?



7. Is 1 sq. ft. about .1 sq. yd., or about .01 sq. yd., or about .001 sq. yd.?
8. What part of a square mile = 64 acres? 6.4 acres? .64 acres?
9. How many square inches are there in one square foot?
10. What part of a square foot = 1.44 sq. in.? 14.4 sq. in.?
11. Do 72 sq. in. equal .5 sq. ft., or .05 sq. ft., or .005 sq. ft.?
12. 1 gallon contains 231 cubic inches. What part of a gallon = 23.1 cu. in.?
13. Are 3 cu. in. more than .01 gallon, or less than .01 gallon?
14. Are 200 lb. equal to .1 ton, or .01 ton, or .001 ton, or .0001 ton?
15. 20 lb. = what part of a ton? 16. 2 lb. = what part of a ton?
17. Name something that you could do in about .001 hr.
18. Name something that would take you about .01 hr. to do.
19. Name something that would take you about .1 hr. to do.
20. Name something that weighs about .001 lb.
21. Name something that weighs about .01 lb.
22. Name something that weighs about .1 lb.
23. Name something that is worth about .001 dollar.
24. Name something that is worth about .01 dollar.
25. Name something that is worth about .1 dollar.
26. What part of a dollar is a tenth of a cent?
27. Draw a line about .1 ft. long.
28. Draw a line about .2 ft. long.
29. Draw a line about .01 ft. long.
30. Draw a line about .02 ft. long.
31. How many feet equal .1 mile?
32. How many feet make .01 mile?
33. Draw on the blackboard a line about .001 mile long.

State the sums:

- |          |           |            |             |   |
|----------|-----------|------------|-------------|---|
| 1.       | 2.        | 3.         | 4.          | 5. What does 6 count as in the first sum? In the second? In the third? In the fourth? |
| 6000     | 600       | 60         | 6           |   |
| 800      | 80.0      | 8.00       | .800        |   |
| 20       | 2         | .20        | .02         |   |
| <u>9</u> | <u>.9</u> | <u>.09</u> | <u>.009</u> | 6. What does 8 count as in the first sum? In the second? In the third? In the fourth? |
7. What does 2 count as in the first sum? In the second? In the third? In the fourth?
8. What does 9 count as in the first sum? In the second? In the third? In the fourth?
9. How many miles do 30 tenths of a mile equal?
10. 60 tenths of a mile?    11. 40 tenths of a mile?
12. 100 tenths of a mile?    13. 160 tenths of a mile?
14. How many tenths of a mile are there in 6 miles?
15. In 6.3 miles?    16. In 4 miles?    17. In 4.5 miles?
18. In half a mile?    19. In a mile and a half?

## 112.

Write the sums:

- |             |            |            |             |             |             |          |
|-------------|------------|------------|-------------|-------------|-------------|----------|
| 1.          | 2.         | 3.         | 4.          | 5.          | 6.          | 7.       |
|             |            | .002       | 1.008       | 6           | .8          | .06      |
| 2.02        | 3          | 4.1        | .70         | .5          | 2           | .009     |
| 1.30        | .40        | .720       | .08         | .09         | .04         | .7       |
| <u>1.06</u> | <u>.08</u> | <u>.03</u> | <u>.004</u> | <u>.007</u> | <u>.007</u> | <u>3</u> |

8. Find the sum of 24.014, 6.13, 2.08, and 41.3.

When adding or subtracting with decimals write the numbers with the decimal points in a column so that all the digits meaning tenths will be in the same column. Put a decimal point where it belongs in the result.

9. Find the sum of 61.254, 20.82, 9.055, 57.3, and 80.
10. Subtract 2.145 from 4.8. (Think of 4.8 as 4.800.)
11. Subtract 6.375 from 9.48. (Think of 9.48 as 9.480.)
12. Subtract 2.125 from 7. (Think of 7 as 7.000.)
13. Check your results for 10, 11, and 12 by adding.

## 113.

Subtract each of these numbers from 5.7. You may think of 5.7 as 5.70 or 5.700.

1.	2.	3.	4.	5.	6.	7.
2.15	3.179	2.07	3.36	4.082	3.2	4.

8. Add .341, 1.215, .07, 1.6, and .009.

Subtract 2.4 from each of these numbers. You may think of 2.4 as 2.40 or 2.400.

9.	10.	11.	12.	13.	14.	15.
8.637	7.9	9.58	5	6.08	6.008	8.4

Add 2.415 to each of these numbers:

16.	17.	18.	19.	20.	21.	22.
6.312	631.2	63.12	7.42	0.742	7.42	241.5

## 114.

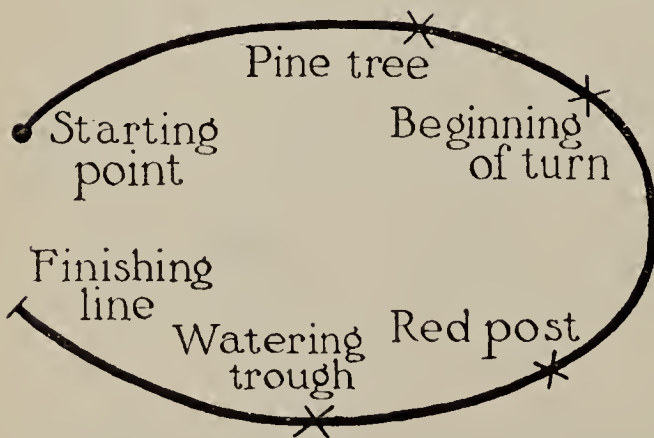

The boys measured this track in the middle of the road. It is exactly 1 mile (or 1.000 mi.) long. From the starting point to the pine tree is .276 mi. From the pine tree to the beginning of

the turn is .124 mi. From the beginning of the turn to the red post is .22 mi. From the red post to the watering trough is .165 mi.

1. Find how far it is from the starting point to —
  - a. Beginning of turn.
  - b. Red post.
  - c. Watering trough.
2. Find how far it is from each of these to the finishing line:
  - a. Beginning of turn.
  - b. Red post.
  - c. Watering trough.
3. How far beyond the beginning of the turn should a mark be set to be exactly  $\frac{1}{2}$  mile from the starting point?
4. How far is it from the pine tree to the finishing line?

Subtract each of these from 1 mile:

5.	6.	7.	8.	9.	10.
.75 mi.	.4 mi.	.5 mi.	.375 mi.	.087 mi.	.25 mi.

### 115. Hundredths

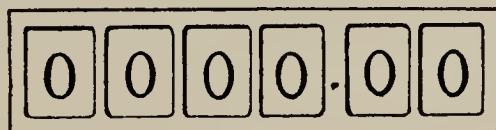

This is a special cyclometer that shows thousands, hundreds, tens, ones, tenths, and hundredths of a mile. Alice's father had one which he put on her bicycle.

Find the length of each of these trips from the amounts the cyclometer showed at the start and at the finish of each trip.

	At the Start	At the Finish
<b>Trip 1.</b>	0000.00	0011.46
<b>Trip 2.</b>	0011.46	0016.89
<b>Trip 3.</b>	0016.89	0050.03
<b>Trip 4.</b>	0050.03	0067.20
<b>Trip 5.</b>	0067.20	0078.50

6. To the school and back is 1.13 mi. How far does Alice go in making 4 trips to school and back?
7. Check your answer by adding four 1.13s.



8. How can you know just by looking at  $1.1\overline{3}$  that the product is not so little as  $.452$  mi.?
9. How can you know that the product is not so much as  $45.2$  mi.?
10. The distance to Alice's grandfather's house and back is  $3.86$  miles. One day Alice rode there and back 3 times. How many miles did the three trips make?
11. How can you know that the product is not so little as  $1.158$  mi.?
12. How can you know that the product is not so large as  $115.8$  mi.?
13. Alice planned to ride 500 miles before Sept. 1. By the middle of August she had ridden  $391.27$  miles. How many miles more must she ride to complete the 500 miles?

## 116.

1. How far can Alice ride in 4 minutes at  $.2$  mi. per minute?
2. How far can John ride in 4 minutes at  $.3$  mi. per minute?
3. How far can an automobile go in 8 minutes at  $.4$  mi. per minute?
4. How far can an automobile go in 8 minutes at  $.6$  mi. per minute?
5. How far can a racer go in 8 minutes at  $1.1$  mi. per minute?
6. How far can an airplane go in 3 minutes at  $1.6$  mi. per minute?

State the products for each of these:

7. 3 tenths multiplied by 2. By 7. By 4. By 9. By 10.
8. 5 tenths multiplied by 3. By 9. By 5. By 10. By 2.
9. 12 hundredths multiplied by 3. By 2. By 4. By 6. By 10.

10. 15 hundredths multiplied by 3. 25 hundredths multiplied by 3.
11. .25 multiplied by 3. By 4. By 2. By 6. By 5. By 10.
12. 1.1 multiplied by 4. By 3. By 2. By 5. By 6. By 7.
13. 1.2 multiplied by 2. By 3. By 4. By 7. By 6. By 10.
14. 2.5 multiplied by 5. By 2. By 3. By 4. By 10. By 6.

**Be sure to put the decimal point where it belongs.**

**Look at the numbers and think.**

15. Here are some of the supplies Henry's uncle took when he went on an exploring trip. Find the weight of each lot.
- 8 packages of chocolate, each weighing .32 lb.
  - 6 packages of pemmican, each weighing .28 lb.
  - 3 packages of tea, each weighing .09 lb.
  - 4 packages of canned meat, each weighing 1.13 lb.
  - 30 yards of rope weighing .17 lb. per yd.
  - 4 little cans of oil, weighing 1.07 lb. per can.

117.

Write the products:

1.	2.	3.	4.	5.	6.	7.	8.
3.4	9.13	6.41	7.2	25.12	4.6	2.98	5.1
<u>6</u>	<u>2</u>	<u>7</u>	<u>4</u>	<u>5</u>	<u>8</u>	<u>3</u>	<u>9</u>

9. Which of the multiplicands of Ex. 1 to 8 have one decimal place? Which of the multiplicands of Ex. 1 to 8 have two decimal places? Which of the products of Ex. 1 to 8 have one decimal place? Which of the products of Ex. 1 to 8 have two decimal places?

Ruth's father and uncle were planning for a hunting trip. They were taking provisions to last 14 days. They reckoned on —

3.2 lb. flour per day.  
 1.16 lb. bacon per day.  
 .18 lb. coffee per day.  
 .075 lb. salt per day.  
 .225 lb. sugar per day.

1. How much would the supply of flour for 14 days weigh?  
 Be sure to put the decimal point in the product where it belongs. Look at the numbers and think.
2. They took 50 lb. flour. How much more was this than they reckoned they would need?
3. How much would the supply of bacon for 14 days weigh?
4. Will 16 lb. bacon be enough?
5. How much would the supply of coffee for 14 days weigh?
6. They took 2.5 lb. coffee. How much less was that than what they reckoned on?
7. How much would the salt for 14 days weigh?
8. How much will sugar for 14 days weigh at .225 lb. per day?

Using the estimates of Ruth's father and uncle —

9. How much flour would they need for a 10-day trip?
10. How much bacon would they need for a 10-day trip?
11. How much coffee? 12. How much salt? 13. How much sugar?

To multiply a decimal number by 10, move the decimal point one place to the right. Annex 0 if necessary.

14. How much flour would be needed for a 100-day trip?
15. How much bacon would be needed for a 100-day trip?
16. How much coffee? 17. How much salt?
18. Make a rule for multiplying a decimal by 100.

1. If 3.2 lb. flour is needed per day for 2 men, how much flour is needed per day for 1 man? For 10 men? For 100 men? For 20 men?
2. Sugar is sometimes packed for camping in little packages containing  $\frac{1}{8}$  lb. each. How many such packages will 25 lb. sugar make?
3. Ruth's father bought 3 strips of bacon weighing  $18\frac{3}{4}$  lb. in all. What was the average weight per strip?
4. He cut off a piece weighing  $2\frac{1}{2}$  lb. How much of the  $18\frac{3}{4}$  lb. did that leave?
5. At 21¢ per pound, what did the  $18\frac{3}{4}$  lb. bacon cost?
6. At 196 lb. per barrel, how many 32-lb. bags of flour can you get from a barrel? How much flour will be left over?
7. It costs the dealer \$26.75 for materials and labor to measure, wrap, and seal 12,000  $\frac{1}{8}$ -lb. packages of sugar. The sugar itself costs him  $5\frac{1}{4}$ ¢ per pound. What is the total cost?
8. If he sells them all at \$1.25 per hundred, how much does he receive?
9. The sugar weighs  $\frac{1}{8}$  lb. and the wrapper  $\frac{3}{8}$  oz. How many ounces does the whole package weigh?
10. Tell the missing fractions:

A. 2 ounces = ... of a pound      B. 3 = ... of a dozen

8 ounces = ... of a pound      4 = ... of a dozen

4 ounces = ... of a pound      8 = ... of a dozen

12 ounces = ... of a pound      6 = ... of a dozen

C. 1 qt. = ... pk.      D. 6 in. = ... ft.      E. 25 ¢ = ... dollar

4 qt. = ... pk.      6 in. = ... yd.       $33\frac{1}{3}$ ¢ = ... dollar

6 qt. = ... pk.      9 in. = ... ft.       $66\frac{2}{3}$ ¢ = ... dollar

2 qt. = ... pk.      9 in. = ... yd.      75 ¢ = ... dollar



## 120. The Meaning of Very Small Numbers

$$.1 = \frac{1}{10}$$

$$100 \times .1 = 10$$

$$.01 = \frac{1}{100}$$

$$100 \times .01 = 1$$

$$.001 = \frac{1}{1000}$$

$$100 \times .001 = .1$$

$$.0001 = \frac{1}{10000}$$

$$100 \times .0001 = .01$$

*.0001 lb. equals about the weight of a tiny piece of dirt.*

*.0001 ft. equals about the width of the very thinnest line you can draw.*

*.0001 dollar equals the value of about 1 pin, or a match.*

1. Is .0001 mile as long as 1 foot?
2. A mile is 63,360 inches long. What part of a mile = 6336 inches? .01 mi. = 633.6 inches. What part of a mile = 63.36 inches? What part of a mile = 6.336 inches?
3. Draw a square about .0001 sq. yd. in area.
4. Guess how many seconds there are in .0001 day.
5. Find out how many there really are. How near did you guess?

## 121. Multiplying with Decimals

1. What is the area of a rectangular park 1.6 miles wide and 2.45 miles long?

$$\begin{array}{r}
 2.45 \\
 \times 1.6 \\
 \hline
 1470 \\
 245 \\
 \hline
 3.920 \text{ sq. mi.}
 \end{array}$$

2. How can you be sure that  $1.6 \times 2.45$  is not 39.2 sq. mi.?
3. How can you be sure that  $1.6 \times 2.45$  is not .392 sq. mi.

Learn this rule:

Multiply with decimals just as with whole numbers. Then point off as many decimal places in the product as there are in the multiplier and the multiplicand together.

1. Find the area of a rectangle 14.21 miles long and 2.4 miles wide. How many places do you point off in the product?
2. How can you be sure that the area is much less than 341 sq. mi.?
3. How can you be sure that the area is much more than 3 sq. mi.?

Find the products:

4.	5.	6.	7.	8.	9.
4.375	2.68	3.814	130.5	.424	375
<u>1.4</u>	<u>3.1</u>	<u>27</u>	<u>6.25</u>	<u>2.6</u>	<u>.24</u>

### 123. Placing the Decimal Point

Do not multiply with these numbers. Simply look at each example and tell how many decimal places you would point off in the product. Say "none" or "not any" when you would not point off any decimal places at all in the product.

1.	2.	3.	4.	5.	6.	7.	8.
213.2	456.9	87.28	3045	6724	39.13	821.5	6047
<u>2.6</u>	<u>.54</u>	<u>31</u>	<u>60</u>	<u>7.5</u>	<u>.09</u>	<u>.06</u>	<u>.03</u>
9.	10.	11.	12.	13.	14.	15.	16.
300.6	4.082	9.715	5026	20.97	316.2	4.008	5170
<u>.82</u>	<u>90</u>	<u>36</u>	<u>.05</u>	<u>.06</u>	<u>.07</u>	<u>11.4</u>	<u>256</u>
17.	18.	19.	20.	21.	22.	23.	24.
62.53	7190	80.56	750.2	.3147	296.1	8.473	90.40
<u>.19</u>	<u>.08</u>	<u>.07</u>	<u>.03</u>	<u>42</u>	<u>57</u>	<u>69</u>	<u>64</u>
25.	26.	27.	28.	29.	30.	31.	32.
7186	2935	812.7	380.9	60.05	29.61	3854	196.2
<u>53</u>	<u>.125</u>	<u>2.36</u>	<u>.108</u>	<u>70</u>	<u>.05</u>	<u>.06</u>	<u>.09</u>
33.	34.	35.	36.	37.	38.	39.	40.
35.2	21.5	.068	105	.089	254	3.08	.078
<u>21.3</u>	<u>4.17</u>	<u>2.6</u>	<u>4.5</u>	<u>68</u>	<u>17</u>	<u>.84</u>	<u>9.5</u>

## 124. Practice with Decimal Numbers

Be sure that you copy the numbers correctly.

Find the sums of —

1. 32.8472, 4.03, 9.108, 60.8416, 2.075, and 32.8.
2. 6.21, 20.788, 41.7, 32.63, 25.673, and 54.03.
3. 7.09, 5.75, 2.6854, 13.0014, 19.2109, and 8.8.
4. 6.275, 18.05, 17.98, 6.2094, 4.0125, and 28.762.
5. 118.375, 217.9, 250, 24.625, and 315.6.

Subtract each of these numbers from 80.75:

6.	7.	8.	9.	10.
8.692	34.287	9.706	14.385	60.25

Subtract each of these numbers from 100:

11.	12.	13.	14.	15.
38.75	14.925	91.08	76.437	84.026

Subtract each of these numbers from 27.426:

16.	17.	18.	19.	20.
10.326	14.298	16.5	9.4	11.009

Find the products:

A.	21.	22.	23.	24.	25.	26.	27.
	74.5	8.54	43.5	7.28	972	206	403
	<u>6.2</u>	<u>8.5</u>	<u>.80</u>	<u>.67</u>	<u>2.19</u>	<u>.25</u>	<u>.69</u>
B.	28.	29.	30.	31.	32.	33.	34.
	2.83	906	350	76.8	366	.327	8.50
	<u>70</u>	<u>.38</u>	<u>2.05</u>	<u>.44</u>	<u>.51</u>	<u>6.3</u>	<u>76</u>
C.	35.	36.	37.	38.	39.	40.	41.
	364	4.33	.786	9.82	45.3	860	4.27
	<u>.72</u>	<u>24</u>	<u>70</u>	<u>.36</u>	<u>.075</u>	<u>1.9</u>	<u>1.09</u>

Rainfall per Week  
(cu.in. per sq.in. of area)

June	1- 7	1.056
	8-14	1.103
	15-21	1.040
	22-28	.960
	29-July 5	.915
July	6-12	.782
	13-19	.790
	20-26	.670
	27-Aug. 2	.503
Aug.	3- 9	.512
	10-16	.240
	17-23	.215
	24-30	.811

1. In which weeks was the rainfall 1 or more?
2. Which week of August had the largest rainfall for that month?
3. Which was the driest week of the summer? (Driest means with the least rainfall.)
4. Which week was the next to the driest?
5. In which weeks was the rainfall between .800 and 1.000?
6. Look down the table and estimate whether the average rainfall for one week was about .5, or about .6, or about .7, or about .8, or about .9.

(Use pencil for exercises 7 to 15.)

7. At .5 per week what would the total rainfall for 13 weeks be?
8. At .6 per week what would the total rainfall for 13 weeks be?
9. Find what the total rainfall really was by adding.
10. Find what the average rainfall per week really was.  
*Divide just as you have always done. Then put a decimal point in the quotient where you think it belongs.*
11. Which is nearest the real average, .6 or .7 or .8?
12. What was the average rainfall per week in a summer when the total rainfall for 13 weeks was 14.56?
13. How much less than .9 was the rainfall of July 6-12?
14. Answer the same question for each later week.
15. What will the total rainfall for a year be if the average per month is 4.092 inches?



## 126. Rainfall Problems

- It rained three times in the first week in May. The rainfall from the first shower was .143. The rainfall from the second was .38. The rainfall from the last was exactly .9. What was the total rainfall for that week?
- How much greater was the rainfall from the third shower than from the other two together?
- At 1.423 per week, what would be the rainfall in 4 weeks?
- Mr. Russell estimated that the rainfall of the first week in May was  $1\frac{1}{2}$ . How near did he estimate?
- How much less than .5 was the rainfall from each of these showers?

<i>a.</i>	<i>b.</i>	<i>c.</i>	<i>d.</i>	<i>e.</i>	<i>f.</i>	<i>g.</i>	<i>h.</i>
.28	.3	.34	.09	.08	.46	.4	.42

## 127.

State the missing numbers:

A.	B.	C.	D.
$.6 + .3 =$	$.9 \times .2 =$	$10 \times \frac{1}{4} \text{ mile} =$	$10 \times .5 =$
$.6 - .3 =$	$.9 \times 20 =$	$10 \times 20 \text{ mi.} =$	$100 \times .5 =$
$.6 \times .3 =$	$.9 \times 2 =$	$10 \times .2 \text{ mi.} =$	$1000 \times .5 =$
$.6 + .02 =$	$.9 - .05 =$	$10 \times 4.2 \text{ mi.} =$	$10 \times 2.3 =$
$.6 - .02 =$	$.9 + .7 =$	$10 \times .42 \text{ mi.} =$	$100 \times 2.3 =$
$.6 \times .02 =$	$.9 \times 100 =$	$10 \times .042 \text{ mi.} =$	$1000 \times 2.3 =$

State the missing numbers. Express each in lowest terms:

E.	F.	G.	H.
$8\frac{1}{4} + \frac{1}{2} =$	$\frac{3}{4} - \frac{1}{8} =$	$\frac{3}{8} \times 11 =$	$\frac{1}{2} \text{ of } 25 =$
$\frac{7}{8} - \frac{1}{2} =$	$\frac{1}{2} \times 5 =$	$\frac{3}{8} \times 25 =$	$\frac{1}{4} \text{ of } 25 =$
$\frac{5}{6} - \frac{1}{2} =$	$\frac{3}{4} \times 10 =$	$\frac{3}{8} \times 5 =$	$\frac{1}{3} \text{ of } 25 =$
$\frac{1\frac{1}{2}}{1\frac{1}{2}} - \frac{1}{2} =$	$\frac{3}{4} \times 11 =$	$\frac{3}{8} \times 15 =$	$\frac{1}{8} \text{ of } 25 =$
$\frac{3}{4} + \frac{1}{8} =$	$\frac{3}{4} \times 18 =$	$\frac{1}{4} \times 25 =$	$\frac{1}{8} \text{ of } 10 =$

## Record of Star Elsie

	Pounds of Milk	Butter-Fat per Pound of Milk
Jan.	1742	.0461
Feb.	1690	.0485
Mar.	1574	.0504
Apr.	1226	.0490
May	1202	.0466
June	1251	.0481

Read this record of the milk given by the cow Star Elsie. The first column tells the number of pounds of milk given by Star Elsie each month. The second column tells what fraction of a pound of butter-fat each pound of milk contained.

1. Read the first line, saying, "In January this cow gave 1742 pounds of milk. There were 461 ten thousandths of a pound of butter-fat per pound of milk." Read the other lines in the same way.
2. How many pounds of butter-fat did the cow produce in Jan.? 3. In Feb.? 4. In Mar.? 5. In Apr.? 6. In May? 7. In June?
8. From your answers to exercises 2, 3, 4, 5, 6, and 7 find the total number of pounds of butter-fat produced in the 6 months.
9. During the whole year of her test this cow produced 562.8 lb. of butter-fat. Find the average number of pounds of butter-fat produced per month during the twelve months. Think where to put the decimal point in the quotient. Check your result by multiplying it by 12.
10. How can you prove that the answer to Ex. 9 cannot be as large as 469 pounds a month?
11. How can you prove that it cannot be as small as 4 and 69 hundredths pounds a month?
12. Find the average number of pounds of milk per day given by Star Elsie in January. 13. In February (28 days). 14. In March. 15. In April (30 days).

Very few cows make as good records as Star Elsie's 562.8 pounds of butter-fat in a year. These are some records of ordinary cows:

A. 142.4 lb. in a year. B. 160.3 lb. in a year. C. 185 lb.

1. Find the value of each cow's product, counting butter-fat as 30¢ per pound.

Here is the best way to find the value for cow A: 
$$\begin{array}{r} 142.4 \\ \times .30 \\ \hline 42.720 \end{array}$$
 The answer means dollars. It is \$42.72.

2. Find the value of Star Elsie's product of 562.8 lb. butter-fat, counting butter-fat at 30¢ per pound.

### 130. Reading Decimal Numbers

(Without pencil.)

Sometimes we read decimal numbers like this:

140.718 one hundred forty, decimal, seven, one, eight

61.05 sixty-one, decimal, zero, five

82.9031 eighty-two, decimal, nine, zero, three, one

8.007 eight, decimal, zero, zero, seven

.44 decimal, four, four

Multiply and read the products in the way shown above, when they are decimal numbers:

A.	B.	C.	D.
$10 \times 9.618$	$100 \times .946$	$2 \times 4.31$	$3 \times 23$
$100 \times 9.618$	$10 \times .12$	$.2 \times 4.31$	$.3 \times 23$
$100 \times .4273$	$100 \times .12$	$.02 \times 4.31$	$.03 \times 23$
$10 \times .341$	$6 \times 11$	$.04 \times 12.1$	$.03 \times 211$
$2 \times .341$	$.6 \times 11$	$.05 \times 15$	$.04 \times 211$
$20 \times .341$	$.06 \times 11$	$.05 \times 11$	$.04 \times 12.2$

**Remember:** In multiplying with decimals point off as many decimal places in the product as there are in the multiplier and multiplicand together.

(Use pencil when you need to.)

1. Express as decimals:

$16\frac{3}{10}$

$29\frac{17}{100}$

$8\frac{1}{5}$

$8\frac{2}{5}$

$7\frac{1}{50}$

2. Express as decimals:

$32\frac{1}{2}$

$16\frac{1}{4}$

$27\frac{3}{4}$

$7\frac{1}{5}$

$9\frac{4}{5}$

3. Multiply both terms of each of these fractions by 125.

Then express the results as decimals:  $\frac{1}{8}$ ,  $\frac{3}{8}$ ,  $\frac{5}{8}$ ,  $\frac{7}{8}$ .

4. What part of \$1.00 is 50 cents? 25 cents? 75 cents?

5. What part of \$1.00 is  $12\frac{1}{2}$  cents?  $37\frac{1}{2}$  cents?  $62\frac{1}{2}$  cents?  
 $87\frac{1}{2}$  cents?

6. What part of 1 is  $.33\frac{1}{3}$ ? 7. What part of 1 is  $.66\frac{2}{3}$ ?

8. Which of the numbers below equals  $4\frac{1}{2}$ ? 9. Which equals  $4\frac{1}{4}$ ? 10. Which equals  $4\frac{1}{3}$ ? 11. Which equals  $4\frac{1}{5}$ ? 12. Which equals  $4\frac{3}{4}$ ? 13. Which equals  $4\frac{2}{3}$ ?

14. Which equals  $4\frac{7}{8}$ ? 15. Which equals  $4\frac{3}{5}$ ?

4.75   4.875   4.20   4.25    $4.33\frac{1}{3}$    4.5   4.60    $4.66\frac{2}{3}$

### 131. Problems

- A rectangular field is 24.6 rods long and 15.8 rods wide. How many square rods does it contain?
- Who goes farther, a man walking 6 hours at the rate of 3.2 mi. per hour, or a boy riding a bicycle for  $1\frac{1}{2}$  hr. at the rate of 13 miles per hour?
- Dick's cyclometer showed 296.14 miles when he started and 317.20 when he returned. How far had he gone?
- Mr. Lewis counts on using 2.85 kilowatts of electricity per working day. How many kilowatts does he count on using per month of 26 working days?
- The distance around the running track in the school yard is exactly .0625 miles. How far does a boy run if he runs 15 times around the track?
- Does he run more or less than 1 mile?



Take a large sheet of paper. Copy these tables, supplying the missing numbers. If you do not know what the right number is, figure it out or look at the front page of this book, find what the number is, and learn it. Keep this sheet of tables to use if you forget any of the measures. Make your words and figures clear and neat.

### Measures of Length or Linear Measure

... inches = 1 foot (ft.)

... feet = 1 yard (yd.)

... feet = 1 rod (rd.)

... feet = 1 mile (mi.)

... yards = 1 rod

... yards = 1 mile

... rods = 1 mile

### Measures of Area or Square Measure

... square inches = 1 square foot (sq. ft.)

... square feet = 1 square yard (sq. yd.)

$272\frac{1}{4}$  square feet = 1 square rod (sq. rd.)

43560 square feet = 1 acre (A.)

$30\frac{1}{4}$  square yards = 1 square rod.

... square rods = 1 acre (A.)

... acres = 1 square mile (sq. mi.)

### Measures of Volume or Capacity

#### Cubic Measure

1 cubic foot = a space  $12 \times 12 \times 12$  in.

... cu. in. = 1 cubic foot (cu. ft.)

1 cubic yard = a space  $3 \times 3 \times 3$  ft.

... cu. ft. = 1 cubic yard (cu. yd.)

#### Liquid Measure

... gills = 1 pint (pt.)

... pints = 1 quart (qt.)

... quarts = 1 gallon (gal.)

#### Dry Measure

... pints = 1 quart (qt.)

... quarts = 1 peck (pk.)

... pecks = 1 bushel (bu.)

The *standard gallon* contains 231 cu. in.

The *standard bushel* contains 2150.42 cu. in.

### Measures of Weight

... ounces (oz.) = 1 pound (lb.)

... pounds = 1 hundredweight (cwt.)

... pounds = 1 ton (T.)

2240 pounds = 1 long ton.

### Measures of Time

... seconds = 1 minute (min.)

... minutes = 1 hour (hr.)

... hours = 1 day (da.)

... days = 1 week (wk.)

... days = 1 regular year (yr.)

366 days = 1 leap year.

1. Supply the missing numbers:

A.	B.
1 yard = ... inches	2 ft. 7 in. = ... inches
7 feet = ... inches	3 ft. 4 in. = ... inches
3 rods = ... yards	1 yd. 8 in. = ... inches
8 rods = ... yards	30 inches = ... ft. and ... in.
$1\frac{1}{2}$ ft. = ... inches	40 inches = ... ft. and ... in.
$1\frac{3}{4}$ ft. = ... inches	27 inches = ... of a yard

2. Reduce 2 lb. 5 oz. to ounces ("Reduce to ounces" means to tell the number of ounces which 2 lb. 5 oz. equal. Think "2 lb. 5 oz. = ... oz.")

3. Reduce 15 quarts to gallons and quarts. ("Reduce to gallons and quarts" means to tell the number of gallons and quarts which 15 quarts equal. Think "15 qt. = ... gal. and ... qt. left over.")

4. Reduce to inches:	5. Reduce to feet and inches:	6. Reduce to pints:	7. Reduce to pounds and ounces:
2 ft. 5 in.	30 in.	$3\frac{1}{2}$ qt.	19 oz.
5 ft.	39 in.	$1\frac{1}{2}$ gallon	25 oz.
2 yd.	15 in.	5 qt. 1 pt.	37 oz.
1 yd. 10 in.	50 in.	$\frac{3}{4}$ gal.	20 oz.

8. Count by 8s to 80, saying, "8 qt. = 1 pk., 16 qt. = 2 pk., 24 qt. = 3 pk.," etc.

9. Count by 7s to 70, saying, "1 wk. = 7 da., 2 wk. = 14 da., 3 wk. = 21 da.," etc.

10. Supply the missing numbers:

A.	B.	C.
4 sq. yd. = .. sq. ft.	1 cu. yd. = .. cu. ft.	3 pk. 2 qt. = .. qt.
2 acres = .. sq. rd.	3 cu. yd. = .. cu. ft.	5 pk. 3 qt. = .. qt.
$\frac{1}{4}$ acre = .. sq. rd.	7 gallons = .. qt.	21 ounces = .. lb. ... oz.
$\frac{1}{2}$ sq. mi. = .. acres	$\frac{1}{2}$ bushel = .. pk.	3 wk. 2 da. = .. days
$1\frac{1}{2}$ sq. mi. = .. acres	$\frac{1}{2}$ bushel = .. qt.	6 tons = .. lb.

*(Without pencil.)*

1. Add. Express any sum 12 in. or over as ft. and in.

*Do not say 26 in. Say 2 ft. 2 in. Do not say 19 in. Say 1 ft. 7 in.*

a.	b.	c.	d.	e.	f.	g.	h.
	4 in.	6 in.	7 in.			5 in.	
9 in.	8 in.	9 in.	8 in.	7 in.	6 in.	7 in.	4 in.
<u>9 in.</u>	<u>7 in.</u>	<u>10 in.</u>	<u>6 in.</u>	<u>11 in.</u>	<u>5 in.</u>	<u>3 in.</u>	<u>5 in.</u>

2. Add. Express any sum 16 oz. or over as lb. and oz.

*Say 1 lb. 9 oz. for 25 oz. Say 2 lb. 3 oz. for 35 oz.*

a.	b.	c.	d.	e.	f.	g.	h.
	10 oz.		11 oz.		2 oz.	2 oz.	3 oz.
11 oz.	10 oz.	12 oz.	11 oz.	13 oz.	5 oz.	3 oz.	8 oz.
<u>14 oz.</u>	<u>15 oz.</u>	<u>14 oz.</u>	<u>15 oz.</u>	<u>10 oz.</u>	<u>4 oz.</u>	<u>3 oz.</u>	<u>8 oz.</u>

## 135.

*(With pencil.)*

1. Will needs three boards, one 2 ft. 9 in., one 2 ft. 8 in., and one 4 ft. 5 in. Can he get all three from a board 9 ft. long?

<b>ft.</b>	<b>in.</b>	Write the numbers that mean feet under <b>ft.</b>
2	9	Write the numbers that mean inches under <b>in.</b>
2	8	Add the numbers that mean inches first.
4	5	Think, "22 in. = . . . ft. and . . . in."
		Write 10 under <b>in.</b> Add 1 to the <b>ft.</b> column.
		Write ft. and in. with your result to show that the numbers mean feet and inches.

Find the sums:

2.	3.	4.	5.
3 ft. 9 in.	2 lb. 11 oz.	2 ft. 7 in.	1 hr. 25 min.
5 ft. 6 in.	1 lb. 9 oz.	3 ft. 10 in.	1 hr. 10 min.
2 ft. 5 in.	4 lb. 13 oz.	1 ft. 11 in.	1 hr. 15 min.
<u>1 ft. 8 in.</u>	<u>2 lb. 10 oz.</u>	<u>4 ft. 10 in.</u>	<u>1 hr. 30 min.</u>

1. Dora went to play at 25 minutes past 3. She promised her mother to come back at 5 o'clock. How long may she play?

**hr. min.** Write the numbers that mean hours under **hr.**

5 Write the numbers that mean minutes under **min.**

$\begin{array}{r} 3 \quad 25 \\ \hline \end{array}$  Think, "25 and... = 60." Write 35 under the 25 in  
1 hr. 35 min. the **min.** column.

Increase 3 to 4. Write 1 under the 3 and 5 in the **hr.** column.

Write hr. and min. with your result to show that the numbers mean hours and minutes.

2. The train leaves New York at quarter past one and reaches Albany at 5:10 that afternoon. How long does it take to go from New York to Albany?

**hr. min.** Think, "15 is more than 10." Increase 10 by 60.

$\begin{array}{r} 5 \quad 10 \\ \hline \end{array}$  15 and... = 70. Write 55 in the minutes place.

$\begin{array}{r} 1 \quad 15 \\ \hline \end{array}$  Increase 1 to 2. Write 3 in the hours place.

3 hr. 55 min. Write hr. and min. with your result to show what the numbers mean.

The 14-year-old record for the running broad jump at the Lee School is 13 ft. 5 in.

3. John jumped 9 ft. 7 in. How much below the record was John?

4. Fred jumped 10 ft. 2 in. How much below the record was Fred?

5. Henry jumped 9 ft. 11 in. How much below the record was Henry?

The 12-year-old record for the quantity of tomatoes raised on a school garden plot was 14 pecks and 3 quarts.

6. Helen raised 11 pk. 5 qt. How near did she come to the record?

7. Grace raised 12 pk. 3 qt. How near did she come to the record?



## 137. Multiplication

- Kate's father and uncle made up some emergency rations to take on their hunting trip. Each ration contained 8 oz. of sweet chocolate, 8 oz. of hardtack, and a 2-oz. package containing tea, matches, and a cube of fire-lighter. The wrapper and cord weighed 3 oz. How much did the whole ration weigh when wrapped?
- How much will 6 emergency rations weigh, if each one weighs 1 lb. 5 oz.?

**lb. oz.**      *First multiply the number that means ounces.*

1 5      *Think, "30 oz. = ... lb. and ... oz."*

6      *Write 14 in the ounces place.*

7 lb. 14 oz.      *Think "6 × 1 = 6. 6 and 1 = 7." Write 7 in the pounds place.*

*What shall you write with your result to show what the numbers mean?*

- How much will 10 rations, each weighing 1 lb. 5 oz., weigh?
- Their regular ration weighs 2 lb. 3 oz. How much will a dozen regular rations weigh?
- They needed 8 pieces of rope for their tent, each piece to be 3 ft. 10 in. long. Will 30 ft. of rope be enough?
- How much wire is required to make 8 pieces 2 ft. 3 in. long?

**ft. in.**

2 3  
8

18 ft.

*Think, "24 inches = ... ft."*

*Add 2 to the 16.*

Find the products:

- |                             |                             |
|-----------------------------|-----------------------------|
| 7. $4 \times 9$ ft. 10 in.  | 10. $10 \times 3$ pk. 3 qt. |
| 8. $9 \times 3$ lb. 4 oz.   | 11. $6 \times 4$ ft. 8 in.  |
| 9. $8 \times 1$ hr. 12 min. | 12. $12 \times 1$ lb. 3 oz. |

(Without pencil.)

1. State the sums:

- a. 2 ft. 7 in. and 1 ft. 3 in.  
 b. 4 lb. 5 oz. and 2 lb. 2 oz.  
 c. 1 hr. 15 min. and 1 hr. 20 min.  
 d. 2 hr. 40 min. and 1 hr. 30 min.  
 e. 2 ft. 10 in. and 3 ft. 6 in.  
 f. 11 ounces and 10 ounces.

2. State the differences that result when you subtract:

- a. 1 ft. 2 in. from 4 ft. 8 in.  
 b. 1 ft. 7 in. from 3 ft.  
 c. 2 lb. 5 oz. from 3 lb. 8 oz.  
 d. 45 min. from 1 hour.  
 e. 25 sec. from 2 min.  
 f. 4 min. 10 sec. from 6 min.

	Hr.	Min.
Lv. New York . . . . .	9	10
“ Harmon . . . . .	10	12
“ Peekskill . . . . .	10	27
“ Beacon . . . . .	10	56
“ Poughkeepsie . . . . .	11	20
“ Hudson . . . . .	12	31
Ar. Albany . . . . .	1	13

3. Tell how long this train takes to go from New York to Peekskill.

4. From Peekskill to Poughkeepsie.

5. From Poughkeepsie to Hudson.

6. From Hudson to Albany.

7. From New York to Hudson.

8. From New York to Albany.

Mr. Williams sells apples in special baskets containing on an average 3 quarts, at 25 cents a basket. Tell how many pecks and quarts there are in —

9. 6 baskets. 10. 12 baskets. 11. 10 baskets.

He sells potatoes in baskets heaped to hold 1 peck and 2 quarts. How many pecks and quarts are there:

12. In 3 of these baskets? 13. In 5? 14. In 8?

15. If you divide a pound of candy exactly equally among 8 children, how many ounces does each child receive?

16. If a pound is divided equally among 4 children, how many ounces does each receive?

17. If a wire 1 ft. 6 in. long is cut into 5 equal pieces, how long is each?

## 139. Division

1. The heights of the eleven players of the Clinton High School football team added together make 62 ft. 9 in. What is the average height for a boy on this team?

$$\begin{array}{r} 5 \text{ ft. } 8 \frac{5}{11} \text{ in.} \\ 11 \overline{)62 \text{ ft. } 9 \text{ in.}} \end{array} \quad \begin{array}{l} 62 \div 11 = 5 \text{ ft. and } 7 \text{ ft. remainder.} \\ 7 \times 12 = 84. \\ 84 + 9 = 93. \quad 93 \text{ in. } \div 11 = 8 \frac{5}{11} \text{ in.} \end{array}$$

2. In five trials at the mile run, Dick made records of 6 min. 12 sec., 5 min. 58 sec., 5 min. 34 sec., 6 min. 10 sec., and 6 min. 18 sec. What was his average time?
3. Joe made records of 6 min. 15 sec., 6 min. 10 sec., 5 min. 53 sec., 6 min. 28 sec., and 5 min. 50 sec. What was his average time?
4. A steamboat went from New York to Liverpool in 7 da. 6 hr. on one trip, 7 da. 4 hr. on the second trip, 6 da. 18 hr. on the third trip, and 6 da. 11 hr. on the fourth trip. What was the average time?
5. The heights of the players of the Clinton High School girls' basket-ball team are: 5 ft. 6 in., 5 ft. 7 in., 5 ft. 3 in., 5 ft. 4 in., and 5 ft. 8 in. What is the average height for a girl on this team?

## 140.

(Without pencil.)

The distance around any area is called its perimeter.

1. What is the perimeter of a triangle whose sides are 1 ft. 4 in., 1 ft. 11 in., and 1 ft. 10 in. long?
2. What is the perimeter of a square each of whose sides is 1 ft. 4 in. long?
3. The perimeter of a square is 16 ft. 8 in. How long is each side?
4. The perimeter of a square is 9 ft. 8 in. How long is each side?

1. How many cubic feet are there in a tank 4 ft. 4 in. by  $2\frac{1}{4}$  ft. by 32 in., inside dimensions?

*Express all three dimensions in feet as improper fractions, then multiply. Cancel if you can.*

$$4\frac{1}{3} \text{ ft.} \times 2\frac{1}{4} \text{ ft.} \times 2\frac{2}{3} \text{ ft.} \quad \frac{13}{3} \times \frac{9}{4} \times \frac{8}{3}$$

$$\frac{13}{3} \times \frac{9}{4} \times \frac{8}{3} \quad \text{What is the result?}$$

2. A correct, but longer, way is to express all dimensions in inches, then multiply, and then divide by 1728 to find the number of cubic feet. Do this for Ex. 1 to check your result by the first method.
3. How many cubic feet are there in a tank 10 ft. 8 in. long,  $2\frac{1}{2}$  ft. wide, and 27 in. deep, inside dimensions? Find the result by the first method.
4. Check your result for Ex. 3 by the second method.
5. How many cubic feet will a bin 6.9 ft. by 3.5 ft. by 2.8 ft. hold?
6. How many cubic feet of air are there in a square room 16.5 ft. by 16.5 ft. which is 10.75 ft. high?
7. Check your result for Ex. 6 by  $16\frac{1}{2} \times 16\frac{1}{2} \times 10\frac{3}{4}$ .
8. Which holds more, a bin containing  $2\frac{1}{2}$  cu. yd. or a bin  $5\frac{1}{2}' \times 4\frac{1}{2}' \times 2\frac{1}{2}'$  (inside dimensions)? How much more?
9. How long will it take to excavate 2500 cu. yd. of rock at the rate of 85 cu. yd. per day?
10. How much will it cost to excavate the 2500 cu. yd. at \$2.75 per cu. yd.?
11. Estimating at 18¢ per cubic foot, what is the probable cost of a building containing 875,000 cu. ft.?
12. A tank is to be 8 ft. long and  $2\frac{1}{2}$  ft. wide. How deep must it be to hold 50 cu. ft.?



## 142. Bicycle Races

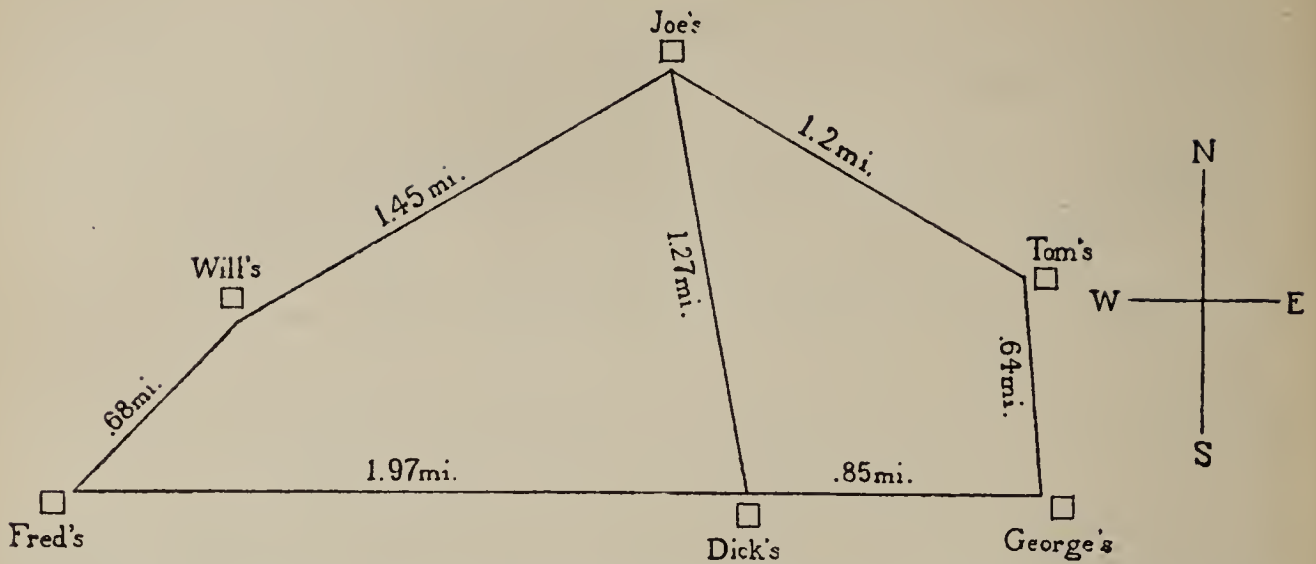

This is a map of the roads where the boys have races on their bicycles.

1. Sometimes they race from Fred's house past Will's to Joe's. How far is that?
2. Sometimes they race from Fred's house past Will's and Joe's and then turn down to Dick's. How far is that?
3. Sometimes they race from Fred's house past Will's, and turn at Joe's going down to Dick's and then back to Fred's. How far is that?
4. They want to put up a post on the way from Dick's to Fred's to make a 5-mile mark on this 5.37 mi. course. How far east of Fred's must the post be?
5. How far west of Dick's must it be?
6. Where should they put a post to make a 4-mile mark on this course?
7. Sometimes they race all the way around from Fred's to Will's, to Joe's, to Tom's, to George's, and then straight west past Dick's to Fred's. How far is that? They call this the long course.
8. If they race the long course and then keep on past Fred's to Will's again, how far do they go?
9. How can they make a 7-mile course?

1. Once Fred rode the 5.37 miles in exactly 13 minutes.  
How far did he go per minute?

$$\begin{array}{r} .41\frac{4}{13} \\ 13 \overline{)5.37} \\ \underline{52} \\ 17 \\ \underline{13} \\ 4 \end{array}$$

*Divide just as with integers (whole numbers).*

*Then put a decimal point in the quotient where it belongs.*

*Look at the numbers and think where the decimal point belongs; or use this rule:*

**When you divide a decimal by an integer (a whole number) point off as many decimal places in the quotient as there are in the dividend.**

*Or use this rule:*

**When you divide a decimal by an integer (a whole number) put the decimal point in the quotient above the decimal point in the dividend.**

2. Once Alice rode the 5.37 mi. in exactly 17 minutes.  
How far did she go per minute?
3. Tom's best time for the 6.79 mi. course is exactly 14 minutes. Did he go as much as a half mile per minute? How far did he go per minute?
4. How far is three times around the 6.79 mi. course?
5. Joe has been three times round the 6.79 course in 50 minutes. How far did he go per minute?
6. Check your answer to Ex. 5 by multiplying 40 by 50, adding 37, and pointing off two decimal places.
7. If Fred could keep on riding for an hour at the rate of .4 mi. per minute, how many miles would he go in an hour?
8. How far must an automobile go per minute to go 71.35 mi. in 60 minutes?
9. How far must an airplane go per minute to go 97.4 mi. per hour?

## 144. Problems about Speed

1. If Dick rode for the first 20 minutes at the rate of .34 mi. per minute, the next 20 minutes at the rate of .28 mi. per minute, and the last 20 minutes at the rate of .17 mi. per minute, how far would he go in an hour?
2. Find the distance per minute that each of these boys and girls went:
  - a. Will rode 5.35 miles in 9 minutes.
  - b. Joe rode 5.35 miles in 8 minutes.
  - c. Tom rode 5.35 miles in 11 minutes.
  - d. Mary rode 6.67 miles in 21 minutes.
  - e. Helen rode 6.67 miles in 23 minutes.
  - f. Dick rode 4.8 mi. in 8 min.
  - g. Paul rode 4.0 mi. in 8 min.
  - h. Bob rode 4.24 mi. in 8 min.
  - i. Sam rode 3.2 mi. in 8 min.
  - j. Ned rode 3.36 mi. in 8 min.

## 145.

(Without pencil.)

Perform the operation indicated and state the result:

A.	B.	C.	D.
$.12 + .08$	$28 \div 4$	$.19 - .10$	$420 \div 7$
$.12 - .05$	$2.8 \div 4$	$.7 + .07$	$42 \div 7$
$9 \times .06$	$.16 - .06$	$.25 \times 4$	$4.2 \div 7$
$9 \times .6$	$.5 \times 5$	$.7 \times .8$	$.9 \times 7$
$10 \times .6$	$.5 \times .5$	$.16 - .09$	$.8 + .8$
$.14 + .04$	$3 \times .06$	$10 \times .01$	$10 \times .06$
$.14 - .04$	$3 \times .6$	$10 \times 1.04$	$10 \times .006$
$9 \times .8$	$3 \times 6$	$10 \times .08$	$10 \times .28$
$9 \times .08$	$3 \times 60$	$100 \times .03$	$10 \times .028$
$6 \times 5$	$25 \div 5$	$100 \times .01$	$8 \times .006$

The teacher sometimes lets the 5th-grade children have a decimal race. They make a track on the blackboard like this, only larger. A child begins at the starting line

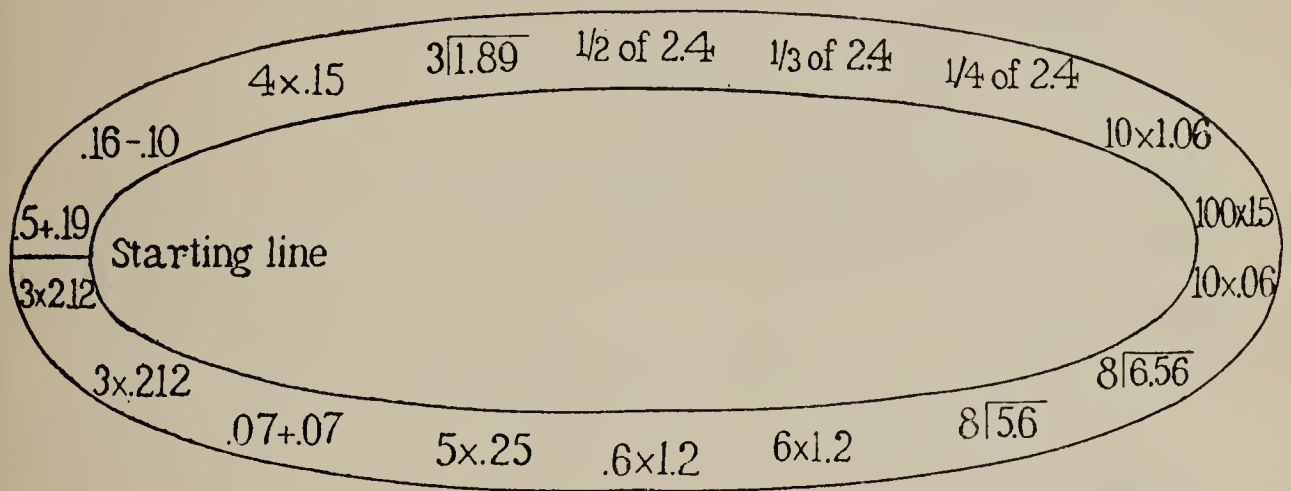

and gives the answers as fast as he can. Some child with a watch that tells seconds keeps the time. The other children watch and listen to see that the racer gives the right answers. If he gives a wrong answer they call "Wrong" and he has to stop and find the right answer before he goes on.

Practice with these so that you can make a good record.

A.	B.	C.	D.
$4.8 \div 8$	$1.25 \div 5$	$10 \times .18$	$7 \times .008$
$2.4 \div 2$	$4.00 \div 8$	$100 \times .18$	$2 \times .143$
$.5 \times 12$	$3.0 \div 5$	$100 \times .27$	$3 \times .211$
$.7 \times 9$	$4.5 \div 9$	$\frac{1}{2}$ of 48	$2 \overline{)8.44}$
$.3 \times 12$	$1.44 \div 12$	$\frac{1}{2}$ of 4.8	$2 \overline{).844}$
$.3 \times 15$	$1.50 \div 3$	$\frac{1}{2}$ of .48	$2 \overline{)84.4}$
$.3 \times 1.5$	$1.6 + .4$	$\frac{1}{2}$ of 2.48	$3 \overline{)39.6}$
$.36 - .09$	$1.6 - .4$	$\frac{1}{3}$ of 36	$3 \overline{)3.96}$
$.08 + .08$	$1.6 \times .4$	$\frac{1}{3}$ of .36	$3 \overline{).396}$
$.06 + .06$	$10 \times 1.6$	$\frac{1}{3}$ of 3.6	$8 \overline{)6.4}$



(Without pencil.)

What is the exact cost of one article —

1. When you get 10 for a cent?
2. When you get 5 for a cent?
3. When you get 100 for a cent?
4. When you get 50 for a cent?
5. When you get 25 for a cent?
6. When you get 4 for a cent?

(With pencil.)

7. What is the exact cost of one article when you get 16 for 25 cents?

$$\begin{array}{r}
 \$.015625 \\
 16 \overline{) \$.250000} \\
 \underline{16} \phantom{0000} \\
 90 \phantom{000} \\
 \underline{80} \phantom{00} \\
 100 \phantom{0} \\
 \underline{96} \phantom{0} \\
 40 \\
 \underline{32} \\
 80 \\
 \underline{80} \\
 0
 \end{array}$$

Think, "There is one 16 in 25." Write 1 over the 5. Put a decimal point in the quotient above the decimal point in the dividend. Write 0 over the 2 of 25. Annex 0 to the dividend and continue dividing. Continue until the division is exact.

8. What is the exact cost of one article when you get 16 for a dollar?
9. Check your result in 8 by multiplying the quotient by the divisor.
10. What is the exact cost of one article when you get 8 for \$.75? Check your result.
11. What is the exact cost of one article when you get a dozen for \$.75? Check your result.

Find the exact cost of one article when you get —

12. 4 for 50 cents.    13. 30 for \$1.35.    14. 8 for a cent.
15. Find the exact quotient when 2.96 is divided by 32.

1. How many minutes will it take a motorcycle to go 12.675 miles at the rate of .75 mi. per minute?

$$\begin{array}{r} 16.9 \\ .75 \overline{)12.675} \\ \underline{75} \phantom{0} \\ 517 \\ \underline{450} \\ 675 \\ \underline{675} \end{array}$$

2. Check by multiplying 16.9 by .75.  
 3. How do you know that the quotient cannot be as little as 1.69?  
 4. How do you know that the quotient cannot be as large as 169?  
 5. Find the quotient for  $3.75 \div 1.5$ .  
 6. Check your result by multiplying the quotient by the divisor.  
 7. How do you know that the quotient cannot be .25 or 25?  
 8. Look at this problem.  $.25 \overline{)7.5}$   
 How do you know that 3.0 is wrong for the quotient?  
 How do you know that 300 is wrong for the quotient?

State which quotient is right for each of these:

.021 or .21 or 2.1 or 21 or 210

.021 or .21 or 21 or 210

9.  $1.8 \overline{)3.78}$

10.  $1.8 \overline{)37.8}$

.03 or .3 or 3 or 30 or 300

.03 or .3 or 3 or 30 or 300

11.  $1.25 \overline{)37.5}$

12.  $12.5 \overline{)37.5}$

.05 or .5 or 5 or 50 or 500

.05 or .5 or 5 or 50 or 500

13.  $1.25 \overline{)6.25}$

14.  $12.5 \overline{)6.25}$

15. Is this rule true? If it is true, learn it.

**In a correct result, the number of decimal places in the divisor and quotient together equals the number of decimal places in the dividend.**

1. Find the quotients. Place the decimal point so that divisor  $\times$  quotient will equal dividend.

a.  $1.2 \overline{)4.92}$       b.  $16 \overline{)9.92}$       c.  $1.5 \overline{)34.5}$       d.  $1.5 \overline{)3.45}$   
 e.  $1.4 \overline{)31.2}$       f.  $1.4 \overline{)3.22}$       g.  $1.25 \overline{)37.5}$       h.  $1.25 \overline{)375}$   
 i.  $31.2 \overline{)99.84}$       j.  $31.2 \overline{)998.4}$       k.  $2.1 \overline{)8.61}$       l.  $2.1 \overline{)86.1}$

*You may place the decimal point by this rule:*

**Make a mark in the dividend as many places to the right of the decimal point as there are decimal places in the divisor. Place the decimal point in the quotient directly above this mark.**

*Examples A, B, and C show you how to use this rule:*

A.

$$\begin{array}{r} 2.4 \\ 12.1 \overline{)29.0\check{4}} \\ \underline{242} \\ 484 \\ \underline{484} \end{array}$$

B.

$$\begin{array}{r} 1.6 \\ 2.13 \overline{)3.40\check{8}} \\ \underline{213} \\ 1278 \\ \underline{1278} \end{array}$$

C.

$$\begin{array}{r} 8 \\ .75 \overline{)6.00\check{}} \\ \underline{600} \end{array}$$

2. See if the rule always gives the right result. Use it to place the decimal point in *a, b, c, d, e*, etc., and see if the divisor  $\times$  quotient = dividend.

In using the rule, if the dividend is a whole number; place a decimal point at the right of the units figure and annex 0 or 00 as is needed.

a.  $1.5 \overline{)9.3}$       b.  $1.6 \overline{)8.96}$       c.  $1.4 \overline{)294}$       d.  $.25 \overline{)1.125}$   
 e.  $1.3 \overline{)5.59}$       f.  $7.5 \overline{)157.5}$       g.  $1.25 \overline{)875}$       h.  $1.6 \overline{)49.6}$   
 i.  $2.11 \overline{)84.4}$       j.  $12.1 \overline{)605}$       k.  $4.12 \overline{)13.184}$       l.  $.321 \overline{).6741}$

3. At the rate of 1.3 miles per minute, how many minutes will it take an airplane to travel 15.6 miles?
4. How many packages, each containing 2.32 lb., will 116 lb. make?

Another rule which will help you to divide by a decimal number is:\*

Change the divisor to an integer (a whole number) by multiplying it by 10 or 100 or 1000. Multiply the dividend by the same number. Then divide.

Examples A, B, and C show how to use this rule.

$$\begin{array}{r}
 \text{A. } 1.35 \overline{)3.1185} \\
 \text{Multiply by 100} \\
 \text{and use} \\
 \quad 2.31 \\
 \hline
 135 \overline{)311.85} \\
 \underline{270} \\
 418 \\
 \underline{405} \\
 135 \\
 \underline{135} \\
 0
 \end{array}$$

$$\begin{array}{r}
 \text{B. } 2.7 \overline{)1431} \\
 \text{Multiply by 10} \\
 \text{and use} \\
 \quad 530 \\
 \hline
 27 \overline{)14310} \\
 \underline{135} \\
 81 \\
 \underline{81} \\
 0
 \end{array}$$

$$\begin{array}{r}
 \text{C. } 1.125 \overline{).5625} \\
 \text{Multiply by 1000} \\
 \text{and use} \\
 \quad .5 \\
 \hline
 1125 \overline{)562.5} \\
 \underline{5625} \\
 0
 \end{array}$$

1. See if this rule always gives the right result. Use it in *a, b, c, d*, etc.

Test each result by finding whether the unchanged divisor  $\times$  quotient = the unchanged dividend.

$$\begin{array}{llll}
 \text{a. } 2.5 \overline{)9.75} & \text{b. } 1.3 \overline{)6.68} & \text{c. } 1.6 \overline{)80} & \text{d. } .15 \overline{)1.05} \\
 \text{e. } 1.4 \overline{)7.28} & \text{f. } 1.25 \overline{)625} & \text{g. } 7.5 \overline{)82.5} & \text{h. } 1.7 \overline{)57.8} \\
 \text{i. } 3.24 \overline{)680.4} & \text{j. } 11.2 \overline{)8.96} & \text{k. } .302 \overline{).906} & \text{l. } 2.05 \overline{)28.7}
 \end{array}$$

Either rule will always give the right result if you use it correctly and multiply and subtract correctly. But always look at your result and be sure that the number of decimal places in the divisor and the quotient together equals the number of decimal places in the dividend.

\* TO THE TEACHER.—The rule of p. 104 is probably in the long run preferable, because it is more general, involves less mutilation of clerical items, and lends itself a little better to establishing the really vital principle, *Divisor  $\times$  quotient must = dividend. No. of decimal places in divisor + no. of dec. places in quotient must = no. of dec. places in dividend.*

If the rule of p. 104 is that adopted by the school, p. 105 may be omitted. If the rule of p. 105 is that adopted by the school, p. 104 may be omitted.



(Without pencil.)

1. The correct quotient for  $395 \overline{)302175}$  is 765.
  - a. State the correct quotient for  $3.95 \overline{)30.2175}$ .
  - b. State the correct quotient for  $39.5 \overline{)30.2175}$ .
  - c. State the correct quotient for  $.395 \overline{)30.2175}$ .
  - d. State the correct quotient for  $3.95 \overline{)3021.75}$ .
  - e. State the correct quotient for  $39.5 \overline{)302.175}$ .
  - f. State the correct quotient for  $395 \overline{)3021.75}$ .
2. State the correct quotients when the numbers have decimal points as they have here.

A.

*736 is right*

$$349 \overline{)256864}$$

$$34.9 \overline{)2568.64}$$

$$.349 \overline{)256.864}$$

$$3.49 \overline{)2.56864}$$

$$3.49 \overline{)25.6864}$$

$$34.9 \overline{)25.6864}$$

$$.349 \overline{)2.56864}$$

$$349 \overline{)2568.64}$$

$$349 \overline{)256.864}$$

B.

*628 is right*

$$924 \overline{)580272}$$

$$9.24 \overline{)5802.72}$$

$$9.24 \overline{)58.0272}$$

$$92.4 \overline{)5802.72}$$

$$.924 \overline{)58.0272}$$

$$.924 \overline{)5.80272}$$

$$92.4 \overline{)5802.72}$$

$$924 \overline{)580.272}$$

$$924 \overline{)58027.2}$$

C.

*650 is right*

$$475 \overline{)308750}$$

$$.475 \overline{)30.8750}$$

$$4.75 \overline{)308.750}$$

$$47.5 \overline{)308750}$$

$$475 \overline{)30.8750}$$

$$4.75 \overline{)30.8750}$$

$$.475 \overline{)3.08750}$$

$$475 \overline{)308.750}$$

$$47.5 \overline{)308.750}$$

Remember that  $\text{divisor} \times \text{quotient} = \text{dividend}$ .

3. Find the quotients:

a.  $1.1 \overline{)2.2}$

b.  $.9 \overline{)2.7}$

c.  $1.4 \overline{).42}$

d.  $14 \overline{).28}$

e.  $1.8 \overline{)36}$

f.  $.19 \overline{)5.7}$

g.  $1.3 \overline{)65}$

h.  $.9 \overline{)7.2}$

i.  $.53 \overline{)1.06}$

j.  $.53 \overline{)10.6}$

k.  $.41 \overline{)12.3}$

l.  $.4 \overline{)12}$

10 mills = 1 cent.

1. Does 1 mill = \$.01 or \$.001 or \$.0001?
2. What part of a cent is \$.005 or 5 mills?
3. Which of these is the correct sum of 2 dimes, 3 cents, and 4 mills?  

\$.9	\$.09	\$.234	\$.27	\$.54
------	-------	--------	-------	-------
4. Find the exact cost of feeding one cow one day if it costs \$3.072 to feed 12 cows one day.
5. Mr. Edwards estimates that it costs his dairy \$.023 to produce one quart of milk. How much does it cost to produce 10 gallons of milk?
6. Sometimes Mr. Edwards receives from the milk company  $2\frac{1}{2}\text{¢}$  per quart for his milk; sometimes he receives  $2\frac{3}{4}\text{¢}$  per quart; sometimes he receives 3¢ per quart. What does he receive per gallon at each of these prices?
7. If it costs a farmer \$.092 to produce a gallon of milk and he sells it for 11 cents, what is his profit per gallon?
8. During May one of Mr. Edwards' cows gave 1452 lb. milk. How much would that be worth at an average price of \$.014 per lb.?
9. How much butter-fat would 1452 lb. milk produce at an average rate of .043 lb. butter-fat per pound of milk?
10. Mr. Edwards has 28 cows. All together they produced 673.6 lb. butter-fat in June. What was the average number of pounds produced per cow?
11. The cow, Queen's Dolly the 2d, gave 10,440 lb. milk in one year. Counting 22.5 lb. milk required to make 1 lb. butter-fat, how many pounds of butter-fat did Queen's Dolly the 2d produce that year?

(Without pencil.)

1. State the sums:

<i>a.</i>	<i>b.</i>	<i>c.</i>	<i>d.</i>
$\$.33\frac{1}{3}$	$\$.12\frac{1}{2}$	$\$.12\frac{1}{2}$	$\$.25$
$.33\frac{1}{3}$	$.12\frac{1}{2}$	$.12\frac{1}{2}$	$.25$
<u><math>.33\frac{1}{3}</math></u>	<u><math>.12\frac{1}{2}</math></u>	<u><math>.12\frac{1}{2}</math></u>	<u><math>.25</math></u>

2. How many cents =  $\frac{1}{2}$  dollar?3. How many cents =  $\frac{1}{3}$  dollar?4. How many cents =  $\frac{1}{4}$  dollar?5. How many cents =  $\frac{1}{8}$  dollar?6.  $\frac{3}{4}$  dollar = how many cents?

We may write  $\frac{1}{2}$  dollar as  $\$.1/2$ ;  $\frac{1}{3}$  dollar as  $\$.1/3$ ;  $\frac{1}{8}$  dollar as  $\$.1/8$ .

7.  $\$.2/3$  = how many cents?8. What fraction of a dollar is  $12\frac{1}{2}\text{¢}$ ?  $25\text{¢}$ ?  $37\frac{1}{2}\text{¢}$ ?  $50\text{¢}$ ?9. What fraction of a dollar is  $33\frac{1}{3}\text{¢}$ ?  $66\frac{2}{3}\text{¢}$ ?  $75\text{¢}$ ?

Supply the missing numbers:

10.  $\frac{1}{8}$  of 100 =  $\frac{1}{4}$  of 100 =  $\frac{1}{3}$  of 100 =  $\frac{1}{2}$  of 100 =11.  $\frac{3}{4}$  of 100 =  $\frac{2}{3}$  of 100 =  $\frac{3}{8}$  of 100 =

12. What is the exact cost of one article when you get:

(a) 4 for \$1? (b) 3 for \$1? (c) 8 for \$1?

13. At  $25\text{¢}$  each, how many articles do you get: (a) For \$1?

(b) For \$3? (c) For \$5?

14. At  $12\frac{1}{2}\text{¢}$  each, how many articles do you get: (a) For

\$1? (b) For \$2? (c) For \$6? (d) For \$8? (e) For \$5?

15. At  $33\frac{1}{3}\text{¢}$  each, how many articles do you get: (a) For

\$1? (b) For \$4? (c) For \$7?

16. At  $50\text{¢}$  each, how many articles do you get: (a) For \$5?

(b) For \$9? (c) For \$10? (d) For \$25? (e) For \$15?

17. At  $33\frac{1}{3}\text{¢}$  each or  $\$.1/3$ , what is the exact cost: (a) Of

3 articles? (b) Of 12 articles? (c) Of 6 articles?

(d) Of 2 articles?

(Without pencil.)

- Count by 25s to 400, saying, " $2 \times 25¢ = 50¢$ ,  $3 \times 25¢ = 75¢$ ,  $4 \times 25¢ = \$1.00$ ," etc.
- Count by  $12\frac{1}{2}$ s to 200, saying, " $\frac{1}{8}$  of  $\$1.00 = .12\frac{1}{2}¢$ ,  $\frac{2}{8}$  of  $\$1.00 = 25¢$ ,  $\frac{3}{8}$  of  $\$1.00 = 37\frac{1}{2}¢$ ," etc.
- Count by  $12\frac{1}{2}$ s from  $37\frac{1}{2}$  to 150, saying, " $3 \times 12\frac{1}{2} = 37\frac{1}{2}$ ,  $4 \times 12\frac{1}{2} = 50$ ,  $5 \times 12\frac{1}{2} = 62\frac{1}{2}$ ," etc.

W. S. Sheeting costs  $12\frac{1}{2}¢$  per yard.

- What is the exact cost of 5 yd. W. S. sheeting?
- What would you actually pay, 62¢ or 63¢?
- What do you actually pay when the exact cost is  $87\frac{1}{2}¢$ ?  
When it is  $37\frac{1}{2}¢$ ?  $\$1.12\frac{1}{2}¢$ ?  $\$1.37\frac{1}{2}$ ?  $\$1.62\frac{1}{2}$ ?
- Tell the exact cost of these amounts of W. S. sheeting:  
a. 3 yd.   b. 4 yd.   c. 6 yd.   d. 7 yd.   e. 2 yd.  
f. 8 yd.   g. 9 yd.   h. 16 yd.   i. 10 yd.   j. 11 yd.

(With pencil.)

- Which is the easier way for you to find the cost of 14 yards of madras at  $37\frac{1}{2}¢$  per yard, (a) or (b)?

$$(a) \begin{array}{r} \$ .375 \\ 14 \\ \hline 1500 \\ 375 \\ \hline \$5.25 \end{array}$$

$$(b) 14 \times \frac{37}{8} = \frac{21}{4} \text{ or } 5\frac{1}{4}, \$5\frac{1}{4} = \$5.25$$

- Find the products. Take either way you like. Check each result by using the other way. Remember that  $62\frac{1}{2} = \frac{5}{8}$  of 100;  $87\frac{1}{2} = \frac{7}{8}$  of 100.

a. $7 \times \$ .12\frac{1}{2}$	e. $15 \times \$ .12\frac{1}{2}$	i. $31 \times \$ .25$	m. $12 \times \$ .375$
b. $11 \times \$ .37\frac{1}{2}$	f. $12 \times \$ .37\frac{1}{2}$	j. $17 \times \$ .75$	n. $4 \times \$ .125$
c. $9 \times \$ .37\frac{1}{2}$	g. $10 \times \$ .12\frac{1}{2}$	k. $8 \times \$ .12\frac{1}{2}$	o. $6 \times \$ .625$
d. $8 \times \$ .62\frac{1}{2}$	h. $6 \times \$ .87\frac{1}{2}$	l. $12 \times \$ .75$	p. $10 \times \$ .875$





(Without pencil.)

1. At \$1.00 a yard, what is the exact cost of  $\frac{7}{8}$  yd. silk?  
What would you actually pay the clerk?
2. How much less is  $\frac{5}{8}$  of a dollar than  $\frac{2}{3}$  of a dollar?
3. At \$2.00 a dozen, how many articles do you get for \$1.00? What is the exact cost for one article?
4. At \$4.00 a dozen, how many articles do you get for \$1.00? What is the exact cost of one article?
5. If you buy at the rate of 6 for a dollar and sell at 25 cents apiece, how much do you gain on each article?
6. If you buy at the rate of 8 for a dollar and sell at 15 cents apiece, how much do you gain on each article?
7. How much less does it cost per can to buy peaches at 3 cans for a dollar than at 35 cents a can?
8. Mr. Arnheim offers to sell anything in his clothing store at " $66\frac{2}{3}$  cents on the dollar." What do you think this means? How much do you think he would ask for a 9-dollar suit?
9. During bargain week Mr. Stern offers to sell anything in his store at " $12\frac{1}{2}$  cents off on every dollar's worth purchased." What do you think he means? How much do you think he would ask for a 2-dollar dress?

(With pencil.)

10. At  $16\frac{2}{3}$ ¢ per article, how many articles can be bought for \$12.50?  

$$“\div \frac{1}{6}” \text{ means } “6 \times.” \text{ So think } “6 \times 12\frac{1}{2}.”$$
11. At  $37\frac{1}{2}$ ¢ per article, how many can be bought for \$4.50?  

$$“\div \frac{3}{8}” \text{ means } “\frac{8}{3} \times.” \text{ So think } “\frac{8}{3} \times 4\frac{1}{2} \text{ or } \frac{8}{3} \times \frac{9}{2}.”$$
12. Check your result by finding the quotient for  $.375 \overline{)4.50}$ .
13. At  $87\frac{1}{2}$ ¢ per article, how many can be bought for \$10.50?
14. Check your result by finding the quotient for  $.875 \overline{)10.50}$ .

(Without pencil.)

1. How many acres =  $\frac{1}{8}$  sq. mi.?
2. A garden plot is 30 ft. wide. How long must it be made to contain 1500 sq. ft.?
3. What fraction of a square mile is the area of a field  $\frac{1}{2}$  mile long and  $\frac{3}{4}$  mile wide?
4. A field is 20 rd. long and 16 rd. wide. How many sq. rd. does it contain? How many acres does it contain?
5. At the rate of 16 bushels of wheat per acre, how many acres do you plant to get 800 bushels of wheat?

(With pencil.)

6. A farmer plants 30 acres of wheat. He expects to harvest 20.5 bushels per acre. What will the crop be worth at 90¢ per bushel?
7. Mr. Ames reckons that he needs 1200 bushels of corn and that he can grow 40 bushels per acre. So he plants... acres. Find the right number for the space where the dots are.
8. One year Mr. Ames raised 1245 bushels of wheat and sold it for 82¢ per bushel. The next year he raised 1410 bushels and sold it for 76¢ per bushel. In which year did he receive the larger amount of money? How much larger?
9. Mr. Rogers plants 18 acres of corn. How much corn will he harvest: (a) If he grows 50 bu. per acre? (b) If he grows 67.5 bu. per acre? (c) If he grows 75 bu. per acre?
10. The model farm raised  $10\frac{1}{2}$  bu. of wheat on a plot containing  $\frac{1}{4}$  acre. How many bushels would have grown on an acre at that rate?
11. At  $37\frac{1}{2}$ ¢ per lb., how many pounds of seed can be bought for \$1.50?



(Without pencil.)

1. How many feet of fence are needed to inclose a yard 50 ft. by 30 ft.?
2. How long is a chain of 100 links, counting 7.92 in. to a link?
3. Which of these is the same as the quarter-mile run?  
The 220-yd. dash. The 440-yd. run. The 880-yd. run.
4. A street is 800 ft. long. (a) How many houses 25 ft. wide can be built on one side of the street? (b) If the houses are 40 ft. wide, how many can be built?

(With pencil.)

5. How many cubic inches are there in one cubic foot?
6. How many cubic feet are there in 115,500 cu. in.?
7. There are 231 cu. in. in one gallon. How many cu. in. does a 500-gallon tank contain?
8. One cubic foot of water weighs 62.5 lb. What is the weight of the water in a tank containing 23.5 cu. ft., if the tank is full?

### 159. Problems about Business

(Without pencil.)

1. Find the cost of 8 grapefruit at 75¢ per dozen.
2. Find the cost of  $\frac{2}{3}$  yd. velvet at \$1.50 per yd.
3. A girl buys  $3\frac{3}{4}$  yd. cloth at 20¢ a yard and pays with a dollar bill. How much change should she receive?
4. Fred bought a dozen assorted fireworks for 43¢ and sold them for 5¢ each. How many cents profit did he make on the dozen?
5. A boy's earnings were \$18. He spent \$12 and saved the rest. What fraction of his earnings did he spend? What fraction of his earnings did he save?
6. At 25¢ per hour, working 8 hr. per day, how much does a man earn in  $2\frac{1}{2}$  days?



(With pencil.)

7. At 16 for a dollar, what is the exact cost of one article?
8. At 22¢ per sq. ft., what will be the cost of a new floor for a room  $10 \times 12$  ft.?
9. Find the cost of 27,250 ft. of lumber at \$32 per 1000 ft.
10. Knives are bought at the rate of 6 for a dollar and sold for 30¢ apiece. How much is the gain on each knife?
11. A 50-trip ticket costs \$31.80. A regular single-trip ticket costs 80 cents. How much does a person who uses a 50-trip ticket save on each trip?
12. Lucy sold ten chickens, weighing 36 lb. in all, for  $12\frac{1}{2}$ ¢ per lb. How much did she receive?

### 160. Dairy and Poultry Problems

(Without pencil.)

1. How many quarts of milk does a 10-gallon can hold?
2. How many pints does it hold?
3. How many half-pint bottles will a gallon of cream fill?
4. Calling the weight of a gallon of water  $8\frac{1}{3}$  lb., how much will the water in a 100-gallon tank weigh?
5. Counting that 20 pounds of milk makes a pound of butter, how much butter is made from 5 pounds of milk?

(With pencil.)

6. Mr. Edwards counts 8.6 lb. to a gallon of milk. How many pounds does a 10-gallon can full of milk weigh, if the empty can weighs 18.7 lb.?
7. A single cow has given 30,100 lb. milk in a year. How many gallons of milk did the cow give?
8. How many pounds of butter-fat are there in 30,100 lb. milk, at .038 lb. butter-fat per pound of milk?
9. At 1.37 lb. of grain per hen per week how much grain is needed in a year for 50 hens?

(Without pencil.)

1. Louise practiced 1 hr. 20 min. in the forenoon and 45 min. in the afternoon. How long did she practice in all?
2. How many minutes are there in two hours and a quarter?
3. A train travels 60 mi. from 11 A.M. to 12:30 P.M. How many miles does it go per hour?
4. If an automobile goes 12 mi. on a gallon of gasoline costing 18¢, what is the cost per mile for gasoline?

(With pencil.)

5. How far will a train go from 2 P.M. to 4:45 P.M. at an average rate of 36 mi. per hr.?
6. In a 6-day bicycle race one of the riders was off his wheel only 21.75 hours. How many hours was he riding?
7. The winner rode exactly 107.25 hr. and covered 2347.5 miles. What was his average distance per hour?

## 162. Mixed Problems

(With pencil.)

1. Maud made and sold a dozen hats. She used  $1\frac{7}{8}$  yd. ribbon on each hat. How much ribbon did she use in all?
2. She bought a remnant of  $2\frac{5}{8}$  yd. ribbon and cut it in three equal pieces to make bows. How much ribbon was there in each bow?
3. From a piece of cloth 40 yd. long, two pieces were sold, one  $4\frac{3}{8}$  yd. long, the other  $7\frac{1}{2}$  yd. long. How much was sold and how much was left?
4. How many hair ribbons  $1\frac{3}{8}$  yd. long can be cut from a piece  $5\frac{1}{2}$  yd. long?
5. A large crate of berries holds 32 qt. boxes. At \$4.00 a crate, what is the exact cost of 1 quart box of berries?

(Use pencil when you need to.)

State the sums:

1.	2.	3.	4.	5.	6.	7.	8.	9.	10.
$3\frac{1}{2}$	$5\frac{3}{4}$	$3\frac{5}{8}$	$2\frac{3}{4}$	$3\frac{1}{8}$	$3\frac{1}{3}$	$6\frac{1}{4}$	1.6	.9	4.4
<u><math>4\frac{1}{2}</math></u>	<u><math>2\frac{3}{4}</math></u>	<u><math>2\frac{7}{8}</math></u>	<u><math>2\frac{1}{2}</math></u>	<u><math>3\frac{1}{4}</math></u>	<u><math>6\frac{2}{3}</math></u>	<u><math>6\frac{1}{4}</math></u>	<u>2.15</u>	<u>.7</u>	<u>2.03</u>

Read and state the sums:

11.	12.	13.
$2\frac{1}{2} + 1\frac{1}{2}$	11 in. + 9 in. = .. ft. . . in.	.25 mi. + .35 mi.
$\frac{7}{8} + \frac{5}{8}$	10 in. + 6 in. = .. ft. . . in.	$66\frac{2}{3}\text{¢} + 33\frac{1}{3}\text{¢}$
$1\frac{1}{4} + 1\frac{3}{8}$	1 ft. 7 in. + 2 ft. = . . .	$37\frac{1}{2}\text{¢} + 12\frac{1}{2}\text{¢}$
$4\frac{3}{4} + 2\frac{1}{2}$	1 lb. 3 oz. + 1 lb. 6 oz. =	$5\frac{1}{3}\text{ yd.} + 2\frac{2}{3}\text{ yd.}$
$87\frac{1}{2} + 12\frac{1}{2}$	45 min. + 25 min. =	.6 A. + .9 A.

Find the sums:

- |   |   |
|---|---|
| 14. $246\frac{1}{2} + 318\frac{1}{4} + 225\frac{1}{4}$                            | 15. $6\frac{3}{4} + 9\frac{5}{8} + 10\frac{1}{2}$ .                             |
| 16. $14.07 + 8.6 + 21 + 3.12$   | 17. $1.02 + .96 + 1.3$  |
| 18. $7\frac{1}{3} + 6\frac{2}{3} + 5\frac{1}{2} + 8\frac{1}{6}$                   | 19. $\$4.385 + \$2.165$   |
| 20. $\frac{11}{16}\text{ lb.} + \frac{9}{16}\text{ lb.} + \frac{1}{2}\text{ lb.}$ | 21. $\frac{7}{16}\text{ lb.} + \frac{3}{4}\text{ lb.} + \frac{5}{8}\text{ lb.}$ |
| 22. $200.8 + 38.25 + 47$  | 23. $19.5 + 23.08 + 7.6$  |

24. Read these lines, supplying the missing numerators:

- a.  $\frac{1}{2} = \frac{\quad}{4}$  Or  $\frac{\quad}{6}$  Or  $\frac{\quad}{8}$  Or  $\frac{\quad}{12}$  Or  $\frac{\quad}{16}$  Or  $\frac{\quad}{24}$  Or  $\frac{\quad}{10}$  Or  $\frac{\quad}{100}$
- b.  $\frac{1}{4} = \frac{\quad}{8}$  Or  $\frac{\quad}{12}$  Or  $\frac{\quad}{16}$  Or  $\frac{\quad}{100}$        $\frac{2}{3} = \frac{\quad}{6}$  Or  $\frac{\quad}{12}$  Or  $\frac{\quad}{24}$
- c.  $\frac{3}{8} = \frac{\quad}{16}$  Or  $\frac{\quad}{24}$        $\frac{5}{8} = \frac{\quad}{16}$  Or  $\frac{\quad}{24}$        $\frac{3}{4} = \frac{\quad}{8}$  Or  $\frac{\quad}{12}$  Or  $\frac{\quad}{16}$  Or  $\frac{\quad}{24}$

25. Express each of these fractions or mixed numbers in lowest terms, if it is not in lowest terms already:

A.	B.	C.	D.	E.	F.	G.
$\frac{2}{8}$	$\frac{5}{12}$	$\frac{8}{16}$	$\frac{6}{24}$	$\frac{2}{6}$	$4\frac{7}{12}$	$\frac{12}{8}$
$\frac{3}{8}$	$\frac{6}{12}$	$\frac{9}{16}$	$\frac{7}{24}$	$\frac{3}{6}$	$3\frac{4}{12}$	$\frac{13}{8}$
$\frac{4}{8}$	$\frac{7}{12}$	$\frac{10}{16}$	$\frac{8}{24}$	$\frac{4}{6}$	$6\frac{2}{4}$	$\frac{14}{8}$
$\frac{5}{8}$	$\frac{8}{12}$	$\frac{11}{16}$	$\frac{9}{24}$	$1\frac{4}{16}$	$1\frac{6}{8}$	$\frac{15}{8}$
$\frac{6}{8}$	$\frac{9}{12}$	$\frac{12}{16}$	$\frac{10}{24}$	$2\frac{6}{16}$	$1\frac{10}{8}$	$\frac{16}{8}$

(Without pencil.)

- How much must you add to each of these fractions to make  $\frac{7}{8}$ ? a.  $\frac{1}{2}$  b.  $\frac{1}{4}$  c.  $\frac{1}{8}$  d.  $\frac{3}{8}$  e.  $\frac{3}{4}$  f.  $\frac{5}{8}$
- How much must you add to each of them to make 1?
- How much must you add to each of them to make  $1\frac{1}{8}$  or  $\frac{9}{8}$ ?
- How much must you add to each of them to make  $1\frac{1}{4}$ ?

(Use pencil if you need to.)

- Subtract and write the differences:

a.	b.	c.	d.	e.	f.	g.	h.	i.
5	6	$8\frac{1}{8}$	$4\frac{1}{2}$	$7\frac{1}{2}$	$9\frac{1}{4}$	3	$8\frac{7}{8}$	$3\frac{3}{8}$
<u><math>2\frac{2}{3}</math></u>	<u><math>3\frac{3}{4}</math></u>	<u><math>5\frac{7}{8}</math></u>	<u><math>2\frac{1}{4}</math></u>	<u><math>3\frac{3}{8}</math></u>	<u><math>5\frac{3}{4}</math></u>	<u><math>1\frac{5}{8}</math></u>	<u><math>2\frac{5}{8}</math></u>	<u><math>1\frac{3}{4}</math></u>
		j.	k.		l.		m.	
		<u><math>5\frac{1}{4}</math></u>	<u>8 lb. 6 oz.</u>		<u>9 hr. 25 min.</u>		<u>4 wk.</u>	
		<u><math>2\frac{5}{8}</math></u>	<u>3 lb. 10 oz.</u>		<u>4 hr. 50 min.</u>		<u>2 wk. 3 da.</u>	

- How much must you add to each of these distances to make 250 miles?
    - 82.14 mi.
    - 206.73 mi.
    - 97.4 mi.
  - Subtract 75.8 from (a) 100, (b) 212.07, (c) 162.4
  - Which is more,  $\frac{5}{8}$  of 60, or  $\frac{2}{3}$  of 50? How much more?
- (Without pencil.)
- Count by  $12\frac{1}{2}$ s to 100.
  - What fraction of 100 is (a)  $12\frac{1}{2}$ ? (b)  $16\frac{2}{3}$ ? (c) 20?  
(d) 25? (e)  $33\frac{1}{3}$ ? (f)  $37\frac{1}{2}$ ?
  - What fraction of \$1.00 is (a) 50¢? (b)  $62\frac{1}{2}$ ¢? (c)  $66\frac{2}{3}$ ?  
(d) 75¢? (e)  $87\frac{1}{2}$ ¢?
  - Multiply each of these numbers by 10, by 100, and by 1000: 16 2.5  $\frac{1}{4}$  .8 75¢  $\frac{1}{8}$  3.7 2.75 \$.07
  - Divide each of these numbers by 10, by 100, and by 1000: 312.5 \$25.00 60 ft. 300 20 216 42.8 617.5
  - Express as feet and inches:
 

30 in.	40 in.	25 in.	16 in.	28 in.	50 in.	22 in.
--------	--------	--------	--------	--------	--------	--------



Find how many square feet there are in each of these plots:

- |   |                                       |                                       |
|---|---------------------------------------|---------------------------------------|
| 1. $5\frac{1}{2}' \times 8\frac{3}{4}'$ | 2. $4\frac{3}{4}'$ by $6\frac{2}{3}'$ | 3. $7\frac{1}{4}'$ by $6\frac{1}{2}'$ |
| 4. $20.1' \times 7.9'$                  | 5. $10.3'$ by $9'$                    | 6. $15.75'$ by $10'$                  |

Find how many cubic feet of space each of these boxes contains. The boxes are rectangular solids. The numbers are inside dimensions in feet.

- |   |   |
|---|---|
| 7. $3\frac{1}{2} \times 2\frac{3}{4} \times 2\frac{1}{3}$ | 8. $2\frac{1}{4} \times 5\frac{1}{6} \times 2\frac{2}{3}$ |
| 9. $1\frac{1}{2} \times 1\frac{1}{2} \times 4$            | 10. $2.1 \times 3.7 \times 4.2$                           |
| 11. $5.9 \times 4 \times 3$                               | 12. $6.15 \times 5 \times 2.2$                            |

Find the cost of each of these purchases:

Lard is 17¢ per lb. Ham is 21¢ per lb. Bacon is 23¢ per lb.

- |                              |                              |                               |
|------------------------------|------------------------------|-------------------------------|
| 13. $\frac{3}{4}$ lb. lard   | 14. $\frac{3}{4}$ lb. bacon. | 15. 2 lb. 4 oz. ham.          |
| 16. $2\frac{1}{4}$ lb. lard. | 17. 7 lb. ham.               | 18. $3\frac{1}{4}$ lb. bacon. |

The boys in Dover have three tracks or courses for their bicycle races. The short course is .73 mi. The medium course is 1.19 mi. The long course is 2.65 mi. Find how far a boy rides when he goes —

- |   |                 |
|---|-----------------|
| 19. Around the short course three times.  | 20. Five times. |
| 21. Around the medium course three times. | 22. Five times. |
| 23. Around the long course three times.   | 24. Five times. |
25. Find the product of  $2.375 \times 1040$ . Check by  $2\frac{3}{8} \times 1040$ .
26. Find the product of  $2250 \times 10.625$ . Check your result.
27. How long does a girl study in all if she studies 1 hr. 35 min. per day for 8 days? 28. For 30 days?
29. How many feet of wire are needed to make 9 springs, if each spring requires 8 inches?
30. What is the total weight of a dozen packages each weighing 1 lb. 3 oz.?

- |                                      |                                     |                                     |                                     |
|--------------------------------------|-------------------------------------|-------------------------------------|-------------------------------------|
| <b>1.</b> Reduce to<br>ounces:       | <b>2.</b> Reduce to<br>inches:      | <b>3.</b> Reduce to<br>quarts:      | <b>4.</b> Reduce to<br>hours:       |
| 2 lb.                                | 2 yd.                               | 3 bushels                           | 2 days                              |
| 2 lb. 5 oz.                          | 2 yd. 8 in.                         | 2 bu. 2 qt.                         | 3 days                              |
| 4 lb.                                | 10 yd.                              | 1 bu. 12 qt.                        | 4 days                              |
| 1 lb. 9 oz.                          | 1 yd. 9 in.                         | 5 pecks                             | 1½ days                             |
| <b>5.</b> Reduce to<br>hr. and min.: | <b>6.</b> Reduce to<br>wk. and da.: | <b>7.</b> Reduce to<br>ft. and in.: | <b>8.</b> Reduce to<br>lb. and oz.: |
| 200 min.                             | 20 da.                              | 100 in.                             | 40 oz.                              |
| 350 min.                             | 31 da.                              | 25 in.                              | 50 oz.                              |
| 100 min.                             | 15 da.                              | 18 in.                              | 60 oz.                              |
| 500 min.                             | 40 da.                              | 75 in.                              | 18 oz.                              |

**9.** Read, supplying the missing numbers:

A.	B.	C.
In 8 there are ... 4s.	$6 \div 3 =$	$4 = \dots 4$
In 8 there are ... 2s.	$6 \div 2 =$	$4 = \dots 2s$
In 8 there are ... 1s.	$6 \div 1 =$	$4 = \dots \frac{1}{2}s$
In 8 there are ... $\frac{1}{2}s$ .	$6 \div \frac{1}{2} =$	$4 = \dots \frac{1}{3}s$
In 8 there are ... $\frac{1}{3}s$ .	$6 \div \frac{1}{3} =$	$4 = \dots \frac{1}{5}s$
In 8 there are ... $\frac{1}{4}s$ .	$6 \div \frac{1}{8} =$	$4 = \dots \frac{1}{8}s$

(Use pencil when you need to.)

**10.** Find the missing fractions:

A.	B.	C.
$24 = \dots$ of 25	$18 = \dots$ of 20	$12 = \dots \times 6$
$24 = \dots$ of 30	$18 = \dots$ of 25	$12 = \dots \times 5$
$24 = \dots$ of 32	$18 = \dots \times 30$	$12 = \dots \times 8$
$24 = \dots \times 36$	$18 = \dots \times 32$	$12 = \dots \times 9$
$24 = \dots \times 40$	$18 = \dots \times 36$	$12 = \dots \times 15$
$24 = \dots \times 20$	$18 = \dots \times 12$	$12 = \dots \times 21$
$24 = \dots \times 18$	$18 = \dots \times 16$	$12 = \dots$ of 16
$24 = \dots \times 16$	$18 = \dots \times 10$	$12 = \dots$ of 10

(With pencil.)

1.  $3\frac{1}{4}$  yd. ribbon is cut into badges each  $\frac{1}{8}$  yd. long. How many badges will it make? Check your result by  $.125\overline{)3.250}$ .
2. A piece  $8\frac{3}{4}$  yd. long is cut into  $\frac{5}{8}$ -yd. lengths to make napkins. How many will it make? Check your result by  $.625\overline{)8.750}$ .
3.  $2\frac{1}{3}$  hr. is divided into periods each  $\frac{7}{12}$  hr. long. How many periods are there? Check your result by expressing both amounts as minutes and dividing.
4. Divide  $9\frac{3}{8}$  by  $1\frac{7}{8}$ .    5. Divide  $16\frac{1}{2}$  by  $2\frac{3}{4}$ .
6. Divide 16 lb. 2 oz. into 3 equal parts. How heavy is each part?
7. Divide 5 hr. 20 min. into 4 equal parts. How long is each part?
8. Divide 12 ft. 6 in. into 5 equal parts. How long is each part?
9. Find the product of  $1.6 \times 2.25$ .
10. How do you know that the product cannot be as little as .36 or less than 2?
11. How do you know that the product cannot be as much as 36 or more than 6?

To find the number of decimal places in the product add the number of decimal places in the multiplier to the number of decimal places in the multiplicand.

12. Show that this rule is true by using it in these problems and checking as shown:
  - a.  $.25 \times 1.5$ . Check by  $\frac{1}{4} \times 1\frac{1}{2}$ .
  - b.  $3.125 \times 3.2$ . Check by  $3\frac{1}{8} \times 3\frac{1}{5}$ .
  - c.  $2.3 \times 1.7$ . Check by  $2\frac{3}{10} \times 1\frac{7}{10}$ .

Find the exact-quotients when you divide:

- |                    |                   |
|--------------------|-------------------|
| 1. 6217.6 by 1.16  | 2. 7.826 by 3.25  |
| 3. 1395.36 by 40.8 | 4. 140.66 by 5.41 |
| 5. 36.322 by .286  | 6. 32.4 by .675   |

(Without pencil.)

7. In which of these pairs do the two numbers have the same value, or mean the same amount?

- |                            |                     |                     |                          |
|----------------------------|---------------------|---------------------|--------------------------|
| a. $\frac{3}{4}$           | .75                 | l. \$.001           | $\frac{1}{10}$ of a cent |
| b. $\frac{3}{4}$           | $\frac{4}{3}$       | m. $1\frac{5}{8}$   | $\frac{18}{5}$           |
| c. \$10.5                  | \$10.50             | n. $3\frac{1}{4}$   | $\frac{4}{3}$            |
| d. \$10.5                  | $\$10\frac{1}{2}$   | o. 86               | 860                      |
| e. \$10.50                 | \$105               | p. 8.6              | 8.60                     |
| f. 1 bu.                   | 32 qt.              | q. .45              | .450                     |
| g. $1\frac{1}{2}$ bu.      | $32\frac{1}{2}$ qt. | r. .45              | .045                     |
| h. 0146.3 mi.              | 146.30 mi.          | s. $.33\frac{1}{3}$ | $\frac{1}{3}$            |
| i. 018.7 mi.               | 180.7 mi.           | t. $\frac{1}{4}$    | .25                      |
| j. $66\frac{2}{3}\text{¢}$ | $\$ \frac{2}{3}$    | u. $\frac{1}{6}$    | $16\frac{1}{3}$          |
| k. $66\frac{2}{3}$ mi.     | $\frac{2}{3}$ mi.   | v. .4               | $\frac{4}{5}$            |

8. Examine the pairs of numbers again. When the two numbers of a pair do not have the same value, prove that they do not. Use pencil if you need to.

9. Read each of these *equations* or statements of two things that are equal. If the statement is true, say "True." If the equation is not true, say "False." Then change it to make it true.

- |  |   |
|--|---|
| a. $\frac{8}{16} = \frac{1}{2}$                | b. $.08 + .09 = .017$   |
| c. $\$ \frac{3}{8} = 375$ cents.               | d. $12 \times \frac{1}{2} = 12 \div 2$                                |
| e. $9 \div \frac{3}{2} = 9 \times \frac{2}{3}$ | f. $7\frac{1}{2} \div 1\frac{1}{2} = \frac{15}{2} \times \frac{2}{3}$ |
| g. $\frac{1}{8}$ of 24 = $24 \div \frac{1}{8}$ | h. $6 \div \frac{3}{4} = 6 \times \frac{4}{3}$                        |
| i. $100 \times .46 = 46$                       | j. The reciprocal of $3\frac{1}{2}$ is $\frac{2}{7}$ .                |



1. State the reciprocal of each of these numbers:

7	$\frac{1}{3}$	$\frac{3}{5}$	$\frac{1}{4}$	10	$\frac{7}{8}$	$\frac{5}{2}$	$\frac{4}{3}$	4	$\frac{11}{8}$
3	$\frac{1}{2}$	$\frac{9}{4}$	$\frac{8}{3}$	6	$\frac{21}{8}$	$\frac{7}{2}$	$\frac{9}{2}$	$\frac{13}{4}$	$\frac{17}{4}$

To multiply by any number is the same as to divide by the reciprocal of the number.

To divide by any number is the same as to multiply by the reciprocal of the number.

2. Which of these rules do you use when you find  $\frac{1}{3} \times 297$  (by  $3 \overline{)297}$ )?

3. Give three problems that you would solve by the second rule.

4. Perform the operations indicated and state the results:

A.

$$\frac{1}{2} + \frac{3}{4}$$

$$\frac{7}{8} + \frac{5}{8}$$

$$\frac{1}{6} \text{ of } 48$$

$$\frac{1}{2} + \frac{1}{4}$$

$$3 \times 12\frac{1}{2}$$

$$10 \times 1.64$$

$$6 \div \frac{1}{3}$$

B.

$$1\frac{1}{2} - \frac{1}{2}$$

$$\frac{2}{3} + \frac{2}{3}$$

$$\frac{2}{3} \text{ of } 18$$

$$\frac{3}{4} + \frac{1}{8}$$

$$3 \times 16\frac{2}{3}$$

$$100 \times .625$$

$$5 \div \frac{1}{4}$$

C.

$$10 - 2\frac{1}{2}$$

$$1\frac{1}{3} - \frac{2}{3}$$

$$\frac{1}{4} \times 25$$

$$33\frac{1}{3} + 66\frac{2}{3}$$

$$8 \times 25$$

$$10 \overline{)91.7}$$

$$\frac{2}{3} \times 9$$

D.

$$4 \overline{)6 \text{ ft. } 4 \text{ in.}}$$

$$8 \overline{)1 \text{ hr. } 20 \text{ min.}}$$

$$\frac{1}{3} \text{ of two dozen}$$

$$3 \overline{)10 \text{ lb. } 8 \text{ oz.}}$$

$$\frac{1}{2} \times \frac{3}{4} \times \frac{3}{2}$$

$$5 \times \frac{3}{2} \times \frac{4}{3}$$

$$6 \times 7 \times \frac{1}{2}$$

5. Name five integers or whole numbers.

6. Name five proper fractions.

7. Name five improper fractions.

8. Name five mixed numbers.

# ARITHMETIC

## BOOK TWO, PART TWO

### 1. A Vacation Trip

Mr. and Mrs. Sears, with Ruth and Alec, went on a camping trip for their vacation. They carried a tent, blankets, food, and a little stove in a wagon. Ruth and Alec rode on their bicycles.

1. They drove north for 2 weeks and 2 days and spent 1 week 6 days coming back. How long was the whole trip?
2. Mr. and Mrs. Sears drove 438.9 miles in 25 weekdays. How many miles did they average per day?
3. The children rode more than this, because they went to different places on errands and took some side trips. Ruth's cyclometer read 586.7 at starting and exactly 1175 when they reached home. Alec's read 738.46 at starting and 1341.24 when they returned. How far did each child ride?
4. Mr. Sears arranged an old bicycle-cyclometer on the wagon wheel. They found by measuring that when this cyclometer showed 1 mile, the wagon had really gone 2.09 miles. When the cyclometer showed 2 miles, the wagon had really gone 4.18 miles. How far had the wagon really gone when the cyclometer showed 6.4 miles?
5. What did the cyclometer show when they had gone 438.9 miles?

6. Mr. Sears paid \$100 for the horse, \$12 for the harness, and \$48 for the wagon. At the end of the trip he sold all three for \$125. How much did it cost for the use of them during the trip?
7. The tent and stove cost \$21.00. If they last 12 years and Mr. Sears uses them each summer for camping, what will be the annual cost for the use of tent and stove? (Annual cost means cost per year.)
8. They bought food to take with them at a cost of \$16.82, and spent \$21.46 for food on the way. (a) What was the total cost for food for the 29 days? (b) What was the average cost per day for food?
9. Repairs on the wagon cost \$1.45. Oats and hay for the horse cost \$9.28. What was the average daily cost for care of the wagon and feed for the horse?
10. The Sears family always try to earn special money for their vacation, beginning Jan. 1, each year. They try to earn an average of  $83\frac{1}{2}$  cents a day during Jan., Feb., Mar., and April. How much do they try to earn in all during the four months?
11. Mr. Sears tries to earn \$62.50 in all, Mrs. Sears tries to earn \$25.00, and each of the children tries to earn \$6.25. What fraction of the \$100 does each member of the family try to earn as his share of the vacation expenses?
12. Ruth earned \$7.50. Alec earned \$4.50. Did Ruth earn  $1\frac{1}{2}$  times as much as Alec, or  $1\frac{2}{3}$  times as much, or  $1\frac{3}{4}$  times as much?
13. In a previous year Ruth earned \$3.00 and Alec earned \$7.50. How many times as much did Alec earn as Ruth earned?
14. Write three problems about a vacation trip for the class to solve.

1. The Wilson family took a two-weeks trip in their automobile. They went 975.6 miles in all. They did not ride on Sundays. How far did they go per day on the days that they did ride?
2. It cost \$21.32 for gasoline, \$2.80 for oil, and \$4.75 for repairs. Mr. Wilson estimates the wear and tear on the automobile and tires at  $3\frac{1}{4}$  cents per mile traveled. Using this estimate, what was the total cost of running the automobile for the trip of 975.6 miles? Write your answer in this form:

Cost for 975.6 mi. Transportation

Gasoline	.....
Oil	.....
Repairs	.....
Wear and tear of car	<u>.....</u>
Total cost	.....

3. They spent 12 nights and had 12 breakfasts at farmhouses or small hotels. Twice they paid \$1.75 for lodging and breakfast for the family. Five times they paid \$2.00. Four times they paid \$2.50 and once they paid \$3.50. What was the total cost for lodging and breakfasts?
4. They bought food at stores and bakeries for their noon and evening meals, spending \$17.57 in all for the fourteen days. (a) How much did their noon and evening meals cost per day? (b) They expected to spend \$1.40 per day. How much less did they spend per day than they expected?
5. Write three problems about an automobile trip for the class to solve. Write one hard problem; one easy problem; and one very easy problem.



### 3. A Garden

The Noble family have a big yard and garden and do not go away for a vacation. This is a plan of their house, yard, and garden. All dimensions are in feet. All paths are  $4\frac{1}{2}$  ft. wide.

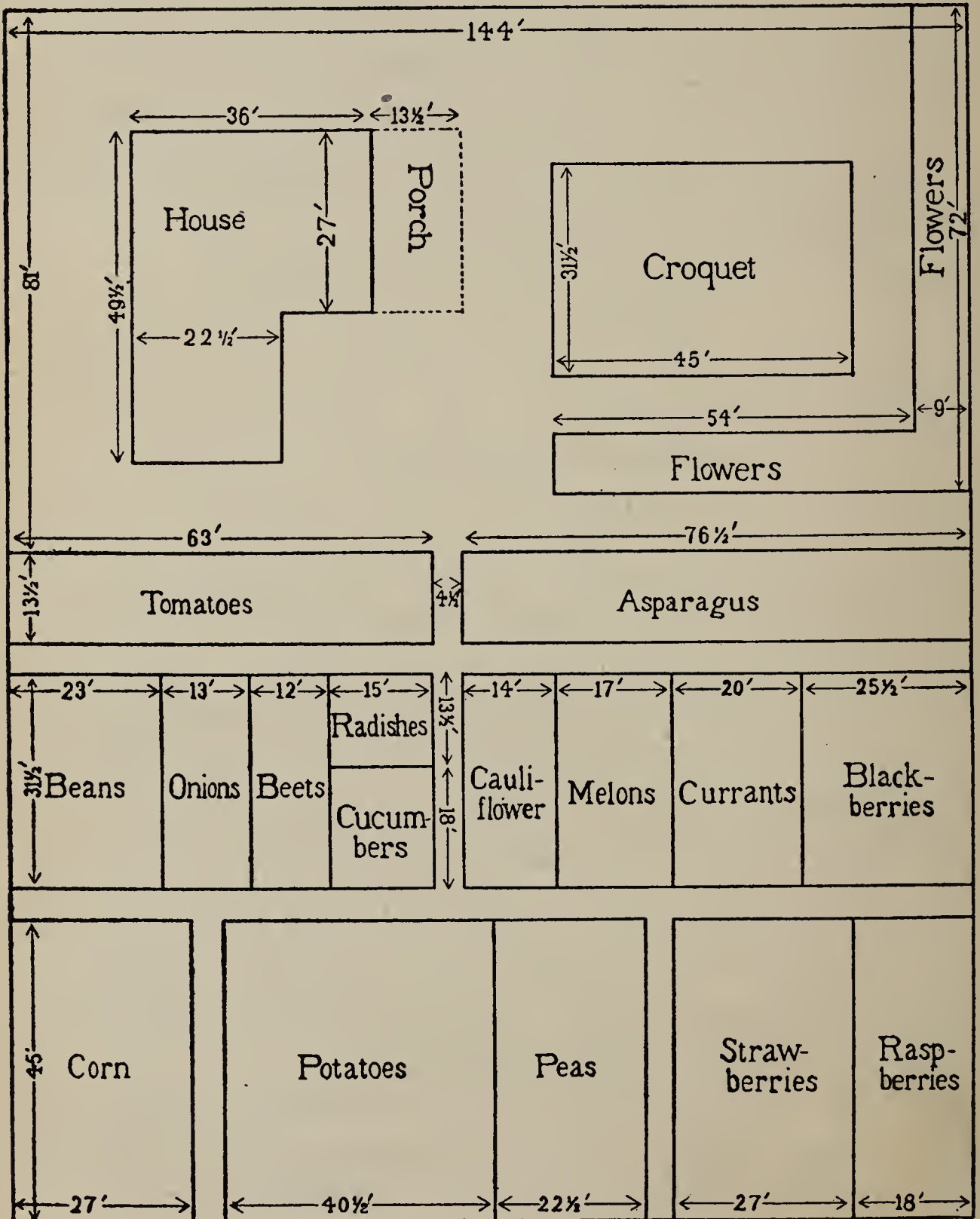

1. How many square feet of ground does their house, without the porch, cover?
2. How many square feet does the house, with the porch, cover?
3. How many square feet are there in the croquet ground?
4. How many square feet are there in the entire lot?
5. How many square feet are there in the vegetable and berry garden and paths?
6. How many square feet are used for paths alone?
7. Make out a table telling how many square feet are used for each sort of vegetable and berry, like this:

	Dimensions	Area in sq. ft.		Dimensions	Area in sq. ft.
Tomatoes	$13\frac{1}{2} \times 63$	$850\frac{1}{2}$	Asparagus	$13\frac{1}{2} \times 76\frac{1}{2}$	....
Beans	.....	....	Cauliflower	.....	....
Onions	.....	....	Melons	.....	....
Beets	.....	....	Currants	.....	....
Radishes	.....	....	Blackberries	.....	....
Cucumbers	.....	....	Peas	.....	....
Corn	.....	....	Strawberries	.....	....
Potatoes	.....	....	Raspberries	.....	....

8. Mr. Noble spent \$4.90 for seed, and bought 8 loads of manure at \$1.12½ per load. He paid \$3.75 for ploughing and harrowing. Incidental expenses for paris green, bordeaux mixture, etc., amounted to \$1.18. Find the sum of all these expenses.
9. Mr. Noble worked in all 108 hours in the garden. Helen worked 168 hours. Arthur worked 214 hours. Counting Mr. Noble's time at 25¢ per hour, Helen's at 12½¢, and Arthur's at 8⅓¢ per hour, what was the labor cost for the garden?

4. Growth

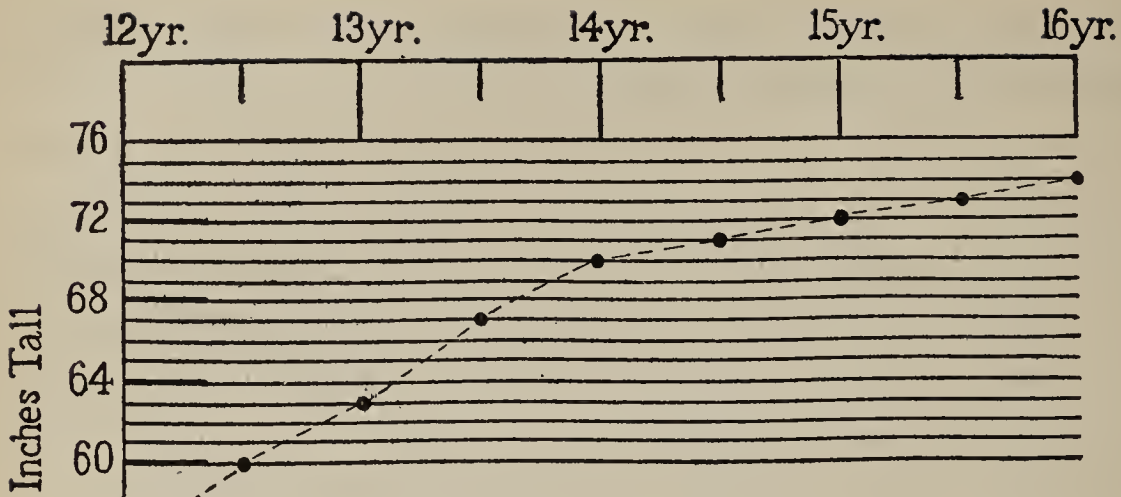

This diagram tells the story of Henry, a boy who grew very, very fast from the time he was 12 till he was 16.  $\frac{1}{16}$  inch up the page represents 1 inch.  $\frac{1}{16}$  inch across the page represents 1 month. Each dot tells how tall Henry was at a certain time.

1. Study the diagram to find out how tall Henry was at 12 yr. 0 mo., at 12 yr. 6 mo., at 13 yr. 0 mo., at 13 yr. 6 mo., at 14 yr. 0 mo., and so on. Write the result in a table like this:

Henry's Height	
At 12 yr. 0 mo. . . .	
At 12 yr. 6 mo. . . .	
At 13 yr. 0 mo. . . .	
At 13 yr. 6 mo. . . .	
At 14 yr. 0 mo. . . .	
At 14 yr. 6 mo. . . .	
At 15 yr. 0 mo. . . .	
At 15 yr. 6 mo. . . .	
At 16 yr. 0 mo. . . .	

2. How many inches did Henry gain each year (a) 12,0 to 13,0, (b) 13,0 to 14,0, (c) 14,0 to 15,0, (d) 15,0 to 16,0?

Supply the missing numbers in Ex. 3 and 4:

3. John gained  $1\frac{1}{2}$  in. Tom gained  $\frac{3}{4}$  in. John gained

....times as much as Tom.

4. Mary gained  $2\frac{1}{4}$  in. Anne gained  $\frac{3}{4}$  in. Mary gained  
....times as much as Anne.

From 12 yr. 0 mo. to 13 yr.  
0 mo.

Dick gained  $\frac{3}{8}$  in.

Fred gained  $\frac{5}{8}$  in.

George gained  $\frac{3}{4}$  in.

Oscar gained  $1\frac{1}{8}$  in.

Paul gained  $1\frac{1}{4}$  in.

Robert gained  $1\frac{1}{2}$  in.

Sam gained  $2\frac{1}{2}$  in.

Supply the missing numbers:

5. George gained ... times as much as Dick.

6. Oscar gained ... times as much as Dick.

7. Robert gained ... times as much as Dick.

8. Sam gained ... times as much as Paul.

9. Sam gained ... in. more than Robert.

10. Sam gained ... in. more than Paul.

11. Sam gained ... in. more than Oscar.

12. Sam gained ... in. more than Fred.

13.  $4\frac{1}{2} = \dots$  times  $1\frac{1}{8}$

14.  $1\frac{1}{3} = \dots$  times  $\frac{2}{3}$

15.  $4 = \dots$  times  $1\frac{1}{3}$

16.  $10 = \dots$  times  $2\frac{1}{2}$

17.  $10 = \dots$  times  $3\frac{1}{3}$

18.  $10 = \dots$  times  $3$

19.  $10 = \dots$  times  $4$

20.  $5 = \dots$  times  $2$

21.  $5 = \dots$  times  $2\frac{1}{2}$

22.  $5 = \dots$  times  $3$

23.  $5 = \dots$  times  $4$

24.  $15 = \dots$  times  $4$

25.  $15 = \dots$  times  $6$

26.  $15 = \dots$  times  $8$

27.  $15 = \dots$  of  $30$

28.  $15 = \dots$  of  $60$

29.  $15 = \dots$  of  $150$

30. At 3 for \$1.00,  
one article costs ...

31. At 6 for \$1.00,  
one article costs ...

32. At 8 for \$1.00,  
one article costs ...

33. At a dollar a dozen,  
one article costs ...

34.  $\frac{3}{8}$  of 100 cents = ...

35.  $\frac{5}{8}$  of 100 cents = ...

36.  $\frac{7}{8}$  of \$1.00 = ...

37.  $\frac{2}{3}$  of \$1.00 = ...

38.  $\frac{3}{4}$  hr. = ... min.

39.  $\frac{2}{3}$  hr. = ... min.

40.  $\frac{5}{12}$  hr. = ... min.

41.  $1\frac{5}{6}$  hr. = ... min.

42. 14 oz. = ... lb.



## 5. Growth in Arithmetical Ability

The children in the Washington School try the speed test on p. 131 every year. Each child takes a wide sheet of paper and writes the numbers 1, 2, 3, 4, etc., to 15 in one column; 16, 17, 18, etc., to 30 in the next column; 31, 32, 33, etc., to 45 in the next column; and 46, 47, 48, etc., to 60, in the last column. Then all the children begin at the same time and see how many correct answers they can write in 5 minutes.

Alice's scores were:

When she was in Grade 4,	29 correct in 5 min.
When she was in Grade 5,	41 correct in 5 min.
When she was in Grade 6,	50 correct in 5 min.
When she was in Grade 7,	57 correct in 5 min.

1. Draw a diagram showing how well Alice did each year.
2. How many did she have correct per minute (a) When she was in Grade 4? (b) When she was in Grade 5? (c) When she was in Grade 6? (d) When she was in Grade 7?
3. When she was in Grade 8, she had all 60 correct in  $4\frac{1}{4}$  min. How many did she have correct per minute that year?
4. One girl in Grade 6 had all 60 correct in 3 min. 48 sec., or 3.8 min. What was her score per minute?
5. Try the speed test on p. 131 yourself. Record the number you do correctly in 5 minutes.
6. Then try the test again and see how much you can improve your score.

## 6. Speed Test

Work as quickly as you can, but make no mistakes. An answer counts on your score only if it is correct. Copy the numbers only when you need to.

A. means add.

S. means subtract.

M. means multiply.

Q. R. means give the quotient and remainder.

$$\begin{array}{r} 1. \text{ A. } 17 \\ \quad \quad 18 \\ \hline \end{array}$$

$$\begin{array}{r} 2. \text{ S. } 75 \\ \quad \quad 25 \\ \hline \end{array}$$

$$\begin{array}{r} 3. \text{ S. } 42 \\ \quad \quad 29 \\ \hline \end{array}$$

$$\begin{array}{r} 4. \text{ A. } 14 \\ \quad \quad 26 \\ \hline \end{array}$$

$$\begin{array}{r} 5. \text{ M. } 12 \\ \quad \quad 12 \\ \hline \end{array}$$

$$\begin{array}{r} 6. \text{ A. } 29 \\ \quad \quad 28 \\ \hline \end{array}$$

$$7. \text{ Q.R. } 9 \overline{)852}$$

$$\begin{array}{r} 8. \text{ A. } 35 \\ \quad \quad 37 \\ \hline \end{array}$$

$$\begin{array}{r} 9. \text{ M. } 25 \\ \quad \quad 69 \\ \hline \end{array}$$

$$10. \text{ Q.R. } 8 \overline{)425}$$

$$11. \text{ Q.R. } 7 \overline{)658}$$

$$\begin{array}{r} 12. \text{ A. } 19 \\ \quad \quad 17 \\ \hline \end{array}$$

$$\begin{array}{r} 13. \text{ S. } 25 \\ \quad \quad 17 \\ \hline \end{array}$$

$$14. \text{ Q.R. } 6 \overline{)550}$$

$$15. 26 + 19$$

$$\begin{array}{r} 16. \text{ S. } 50 \\ \quad \quad 19 \\ \hline \end{array}$$

$$\begin{array}{r} 17. \text{ A. } 16 \\ \quad \quad 17 \\ \hline \end{array}$$

$$18. \text{ Q.R. } 8 \overline{)536}$$

$$\begin{array}{r} 19. \text{ M. } 75 \\ \quad \quad 66 \\ \hline \end{array}$$

$$\begin{array}{r} 20. \text{ A. } 19 \\ \quad \quad 19 \\ \hline \end{array}$$

$$21. \text{ Q.R. } 7 \overline{)446}$$

$$22. 50 - 26$$

$$\begin{array}{r} 23. \text{ S. } 25 \\ \quad \quad 11 \\ \hline \end{array}$$

$$24. \text{ Q.R. } 7 \overline{)359}$$

$$25. 24 + 29$$

$$26. 650 - 32$$

$$27. \text{ Q.R. } 8 \overline{)750}$$

$$\begin{array}{r} 28. \text{ A. } 28 \\ \quad \quad 17 \\ \hline \end{array}$$

$$\begin{array}{r} 29. \text{ M. } 108 \\ \quad \quad 97 \\ \hline \end{array}$$

$$30. \text{ Q.R. } 9 \overline{)556}$$

$$\begin{array}{r} 31. \text{ S. } 25 \\ \quad \quad 19 \\ \hline \end{array}$$

$$32. \text{ Q.R. } 7 \overline{)575}$$

$$\begin{array}{r} 33. \text{ A. } 18 \\ \quad \quad 28 \\ \hline \end{array}$$

$$\begin{array}{r} 34. \text{ A. } 15 \\ \quad \quad 16 \\ \hline \end{array}$$

$$35. \text{ Q.R. } 9 \overline{)763}$$

$$36. \text{ Q.R. } 6 \overline{)400}$$

$$37. 36 + 36$$

$$\begin{array}{r} 38. \text{ A. } 15 \\ \quad \quad 18 \\ \hline \end{array}$$

$$\begin{array}{r} 39. \text{ S. } 850 \\ \quad \quad 37 \\ \hline \end{array}$$

$$40. \text{ Q.R. } 7 \overline{)510}$$

$$41. \text{ Q.R. } 8 \overline{)600}$$

$$\begin{array}{r} 42. \text{ A. } 27 \\ \quad \quad 26 \\ \hline \end{array}$$

$$\begin{array}{r} 43. \text{ M. } 43 \\ \quad \quad 59 \\ \hline \end{array}$$

$$44. \text{ Q.R. } 6 \overline{)500}$$

$$45. 450 - 23$$

$$\begin{array}{r} 46. \text{ A. } 28 \\ \quad \quad 26 \\ \hline \end{array}$$

$$\begin{array}{r} 47. \text{ S. } 25 \\ \quad \quad 16 \\ \hline \end{array}$$

$$\begin{array}{r} 48. \text{ S. } 32 \\ \quad \quad 19 \\ \hline \end{array}$$

$$\begin{array}{r} 49. \text{ A. } 17 \\ \quad \quad 17 \\ \hline \end{array}$$

$$\begin{array}{r} 50. \text{ S. } 25 \\ \quad \quad 18 \\ \hline \end{array}$$

$$\begin{array}{r} 51. \text{ M. } 32 \\ \quad \quad 77 \\ \hline \end{array}$$

$$52. 16 + 28$$

$$53. \text{ Q.R. } 9 \overline{)684}$$

$$\begin{array}{r} 54. \text{ A. } 118 \\ \quad \quad 29 \\ \hline \end{array}$$

$$55. \text{ Q.R. } 6 \overline{)672}$$

$$56. 25 - 16$$

$$\begin{array}{r} 57. \text{ S. } 50 \\ \quad \quad 11 \\ \hline \end{array}$$

$$\begin{array}{r} 58. \text{ A. } 17 \\ \quad \quad 19 \\ \hline \end{array}$$

$$\begin{array}{r} 59. \text{ M. } 109 \\ \quad \quad 46 \\ \hline \end{array}$$

$$60. \text{ Q.R. } 9 \overline{)405}$$

## 7. Arithmetical Language

1. Copy these numbers, writing the integers or whole numbers in one column, the decimal fractions in another column, the common fractions in another column, and the mixed numbers in another column:

268  $\frac{1}{2}$   $\frac{3}{4}$  2.04 397  $\frac{5}{8}$   $42\frac{4}{5}$  456 16.4  $45\frac{1}{5}$  784  
 $\frac{7}{8}$  6.7  $43\frac{1}{5}$   $46\frac{3}{5}$  969 3.275  $50\frac{2}{5}$   $\frac{3}{8}$  18.009

2. Find the sum of the integers.
3. Find the sum of the decimal numbers.
4. Find the sum of the common fractions.
5. Find the sum of the mixed numbers.

## 8.

(Without pencil.)

**A prime number is a number which can be divided without a remainder only by itself and 1.**

1. Say the odd numbers from 1 to 25 and tell of each whether it is prime or not.
2. Are any even numbers prime?

**The separate figures in a number are called digits.**

0 1 2 3 4 5 6 7 8 and 9 are digits.

3. What is the largest number that you can make, using 3 and 9 each once?
4. What is the smallest number that you can make, using the same digits (3 and 9) each once (a) Without a decimal point? (b) With a decimal point?

**A number is divisible by 3 (without remainder) if the sum of its digits is divisible by 3.**

5. Name four numbers that illustrate this rule.
6. Tell quickly which of these numbers are divisible by 3 (without remainder).

315 627 914 280 702 69 74 81

7. Tell any other rules for the divisibility of numbers that you know.

The place value of a digit is the number of ones or units which the digit represents, or means. In 465, the 4 represents 4 hundreds, the 6 represents 6 tens, the 5 represents 5 ones. In  $9\frac{7}{8}$ , the 9 means 9 ones, or units; the  $\frac{7}{8}$  means 7 eighths of a unit.

8. What does each digit represent in each of these numbers?  
 62.508      .3975      269,754      3.862      .04      .008
9. In a common fraction like  $\frac{2}{7}$  or  $\frac{5}{9}$  or  $\frac{1}{6}$  or  $\frac{3}{8}$ , what name is given to the number above the line?
10. What name is given to the number below the line?

## 9.

To multiply a common fraction by a common fraction, cancel if you can. Write the product of the numbers above the line as the numerator of the result. Write the product of the numbers below the line as the denominator of the result.

1. Tell what you divide by when you cancel in each of these. Then tell the result:

<i>a.</i>	<i>b.</i>	<i>c.</i>	<i>d.</i>	<i>e.</i>
$\frac{3}{4} \times \frac{4}{5}$	$\frac{8}{3} \times \frac{9}{8}$	$\frac{17}{12} \times \frac{3}{4}$	$\frac{5}{2} \times \frac{4}{5}$	$\frac{15}{8} \times \frac{7}{10}$

It is customary to express any sum, difference, product, or quotient in lowest terms.

2. Express each of these numbers in lowest terms if it is not in lowest terms already:

$3\frac{6}{8}$	$7\frac{3}{6}$	$\frac{27}{7}$	$\frac{27}{12}$	$\frac{12}{3}$	$\frac{30}{4}$	$\frac{14}{16}$	$1\frac{9}{12}$
----------------	----------------	----------------	-----------------	----------------	----------------	-----------------	-----------------

3. Subtract and express the results in lowest terms:

<i>a.</i>	<i>b.</i>	<i>c.</i>	<i>d.</i>	<i>e.</i>	<i>f.</i>	<i>g.</i>	<i>h.</i>
$\frac{7}{8}$	$5\frac{1}{4}$	$9\frac{1}{6}$	$4\frac{3}{8}$	$7\frac{1}{8}$	$10\frac{1}{3}$	$8\frac{7}{12}$	$3\frac{9}{16}$
<u><math>\frac{3}{8}</math></u>	<u><math>2\frac{3}{4}</math></u>	<u><math>2\frac{5}{6}</math></u>	<u><math>1\frac{5}{8}</math></u>	<u><math>5\frac{7}{8}</math></u>	<u><math>3\frac{5}{8}</math></u>	<u><math>4\frac{5}{12}</math></u>	<u><math>1\frac{5}{16}</math></u>



(Study Ex. 1 to 21 so as to be able to give the results quickly in class. Use pen or pencil only if you need to.)

“Reduce to” means “change to” or “express as.”

1. Reduce 49 ounces to pounds and ounces. 49 oz. = ... lb.... oz.
2. Reduce  $1\frac{5}{8}$  to an improper fraction.  $1\frac{5}{8} = \dots \frac{\quad}{8}$ .
3. Reduce 2 ft. 3 in. to inches. 2 ft. 3 in. = ... in.
4. Reduce  $\frac{79}{1000}$  to a decimal.
5. Reduce  $\frac{32}{64}$  to lowest terms.
6. Reduce 2 hr. 25 min. to minutes.
7. Reduce  $\frac{1}{2}$ ,  $\frac{2}{3}$ ,  $\frac{1}{4}$ ,  $\frac{5}{8}$ , and  $\frac{7}{12}$  each to  $\frac{\quad}{24}$ s, then to  $\frac{\quad}{48}$ s.
8. Reduce  $\frac{5}{32}$ ,  $\frac{11}{32}$ , and  $\frac{29}{32}$  each to  $\frac{\quad}{64}$ s.
9. Reduce 4.3 cents to thousandths of a dollar.
10. Reduce  $1\frac{5}{8}$  lb. to ounces.

11. Read, supplying the missing numerators:

a.  $\frac{1}{2} = \frac{\quad}{10}$  Or  $\frac{\quad}{12}$  Or  $\frac{\quad}{14}$  Or  $\frac{\quad}{16}$  Or  $\frac{\quad}{18}$  Or  $\frac{\quad}{20}$  Or  $\frac{\quad}{24}$

b.  $\frac{2}{3} = \frac{\quad}{12}$  Or  $\frac{\quad}{15}$  Or  $\frac{\quad}{18}$  Or  $\frac{\quad}{21}$  Or  $\frac{\quad}{24}$

c.  $\frac{3}{4} = \frac{\quad}{12}$  Or  $\frac{\quad}{16}$  Or  $\frac{\quad}{20}$  Or  $\frac{\quad}{24}$

d.  $\frac{2}{5} = \frac{\quad}{10}$  Or  $\frac{\quad}{15}$  Or  $\frac{\quad}{20}$

e.  $\frac{5}{6} = \frac{\quad}{12}$  Or  $\frac{\quad}{18}$  Or  $\frac{\quad}{24}$

f.  $\frac{3}{7} = \frac{\quad}{14}$  Or  $\frac{\quad}{21}$

g.  $\frac{5}{8} = \frac{\quad}{16}$  Or  $\frac{\quad}{24}$

h.  $\frac{7}{9} = \frac{\quad}{18}$

12. How can you express  $\frac{\quad}{2}$ s and  $\frac{\quad}{5}$ s so as to add them?
13. How can you express  $\frac{\quad}{4}$ s and  $\frac{\quad}{6}$ s so as to add them?
14. Why is it better to reduce  $\frac{\quad}{4}$ s and  $\frac{\quad}{6}$ s to  $\frac{\quad}{12}$ s than to  $\frac{\quad}{24}$ s?
15. How can you express  $\frac{\quad}{8}$ s and  $\frac{\quad}{12}$ s so as to add them?
16. How can you express  $\frac{\quad}{8}$ s and  $\frac{\quad}{16}$ s so as to add them?

We call fractions that have the same number as denominator "like fractions."  $\frac{5}{16}$ ,  $\frac{7}{16}$ , and  $\frac{13}{16}$  are like fractions.

We call fractions that have different numbers as denominators "unlike fractions."  $\frac{3}{2}$ ,  $\frac{3}{4}$ , and  $\frac{3}{8}$  or  $\frac{1}{3}$ ,  $\frac{5}{6}$ , and  $\frac{7}{12}$  are unlike fractions.

17. Find the sum of each column of like fractions. Express each sum in lowest terms.

<i>a.</i>	<i>b.</i>	<i>c.</i>	<i>d.</i>	<i>e.</i>	<i>f.</i>	<i>g.</i>
		$\frac{3}{64}$	$\frac{3}{64}$	$\frac{5}{12}$	$\frac{1}{16}$	
$\frac{3}{16}$	$\frac{5}{32}$	$\frac{11}{64}$	$\frac{5}{64}$	$\frac{11}{12}$	$\frac{5}{16}$	$\frac{3}{10}$
$\frac{7}{16}$	$\frac{9}{32}$	$\frac{11}{64}$	$\frac{9}{64}$	$\frac{7}{12}$	$\frac{11}{16}$	$\frac{9}{10}$
$\frac{9}{16}$	$\frac{10}{32}$	$\frac{5}{64}$	$\frac{7}{64}$	$\frac{5}{12}$	$\frac{13}{16}$	$\frac{7}{10}$

To add or subtract with unlike fractions, express them as like fractions.

18. How do you express  $\frac{1}{2}$ ,  $\frac{3}{4}$ , and  $\frac{5}{8}$  so as to add them?

19. How do you express  $\frac{2}{3}$  and  $\frac{1}{6}$  so as to add them?

20. The only unlike fractions you will probably ever have to add are fractions like these. Tell the sums:

<i>a.</i>	<i>b.</i>	<i>c.</i>	<i>d.</i>	<i>e.</i>	<i>f.</i>	<i>g.</i>	<i>h.</i>	<i>i.</i>	<i>j.</i>
								$\frac{1}{8}$	
$\frac{1}{6}$	$\frac{1}{4}$	$\frac{2}{3}$	$\frac{7}{8}$	$\frac{5}{8}$	$\frac{1}{6}$	$\frac{3}{16}$	$\frac{5}{16}$	$\frac{3}{4}$	$\frac{9}{16}$
$\frac{1}{2}$	$\frac{1}{2}$	$\frac{1}{2}$	$\frac{1}{2}$	$\frac{3}{4}$	$\frac{1}{3}$	$\frac{1}{4}$	$\frac{5}{8}$	$\frac{1}{2}$	$\frac{1}{2}$

21. If you should ever have to add  $\frac{5}{32}$  and  $\frac{11}{64}$ , how would you express them?

22. If you should ever have to add  $\frac{1}{3}$  and  $\frac{7}{15}$ , how would you express them?

23. If you should ever have to add  $\frac{5}{12}$  and  $\frac{3}{16}$ , how would you express them? (Which are better to use,  $\frac{1}{48}$ s or  $\frac{1}{96}$ s or  $\frac{1}{192}$ s?)

24. In adding  $\frac{1}{6}$  and  $\frac{3}{8}$ , how would you express them? (Which are better to use,  $\frac{1}{48}$ s or  $\frac{1}{24}$ s?)

The reciprocal of any number = 1 divided by that number.

So the product of a number and its reciprocal equals 1.

For example:

$$4 \times \frac{1}{4} = 1 \quad \frac{5}{8} \times \frac{8}{5} = 1 \quad \frac{1}{3} \times 3 = 1 \quad \frac{5}{6} \times \frac{6}{5} = 1$$

1. Give three more illustrations of this fact.
2. Name the reciprocal of each of these numbers:  
6       $\frac{2}{3}$        $\frac{3}{8}$        $\frac{1}{5}$       12       $\frac{11}{2}$        $\frac{15}{4}$        $\frac{9}{10}$        $5\frac{1}{3}$
3. Illustrate this rule: To divide by a number, multiply by its reciprocal.
4. Illustrate this rule: To multiply by a number, divide by its reciprocal.

An equation is a statement that something is equal to something else.

These are equations:

$$36¢ = 4 \times 9¢ \quad 15 = \frac{5}{6} \text{ of } 18 \quad \frac{7}{2} \text{ of } 3 = 10\frac{1}{2} \quad \frac{9}{8} \div \frac{3}{8} = 3$$

5. Supply the missing numbers for these equations:

A.

$$6 \div \frac{3}{4} = \dots$$

$$6 \div \frac{3}{8} = \dots$$

$$10 \div \frac{2}{5} = \dots$$

$$15 = \frac{3}{5} \text{ of } \dots$$

$$6 = \frac{3}{4} \text{ of } \dots$$

$$10 = \frac{2}{5} \text{ of } \dots$$

$$10 \times \frac{4}{5} = \dots$$

D.

$$30 \div \frac{5}{8} = \dots$$

$$30 = \frac{1}{6} \text{ of } \dots$$

$$30 = \frac{1}{3} \text{ of } \dots$$

$$30 = \frac{3}{4} \text{ of } \dots$$

$$30 = \frac{2}{3} \text{ of } \dots$$

$$30 \times \dots = 20$$

$$\frac{3}{4} \times \dots = 6$$

B.

$$15 \div \frac{3}{4} = \dots$$

$$15 \times \frac{3}{4} = \dots$$

$$15 = \frac{3}{4} \text{ of } \dots$$

$$15 = \frac{5}{6} \text{ of } \dots$$

$$15 = \frac{15}{8} \text{ of } \dots$$

$$24 \times \frac{2}{3} = \dots$$

$$24 \times \frac{5}{4} = \dots$$

E.

$$2 = \dots \text{ of } 4$$

$$2 = \dots \text{ of } 6$$

$$2 = \dots \text{ of } 10$$

$$2 = \dots \text{ of } 3$$

$$10 = \dots \text{ of } 40$$

$$10 = \dots \text{ of } 15$$

$$10 = \dots \text{ of } 25$$

C.

$$9 = \frac{1}{2} \text{ of } \dots$$

$$9 = \frac{3}{4} \text{ of } \dots$$

$$12 = \frac{3}{4} \text{ of } \dots$$

$$12 \times 1\frac{1}{4} = \dots$$

$$12 \times 1\frac{1}{2} = \dots$$

$$12 \times \dots = 6$$

$$12 \times \dots = 8$$

F.

$$6 = \dots \text{ of } 16$$

$$8 = \dots \text{ of } 16$$

$$10 = \dots \text{ of } 16$$

$$4 = \dots \text{ of } 16$$

$$12 = \dots \text{ of } 16$$

$$24 = \dots \text{ of } 32$$

$$40 = \dots \text{ of } 60$$

## 12. Arithmetical Language: Complex Fractions\* 137

Fractions like  $\frac{2\frac{1}{2}}{4}$  or  $\frac{4\frac{1}{4}}{8}$  are called **complex** fractions.

If you ever have to perform any arithmetical operation with a complex fraction, first reduce it to a simple fraction, as shown below:

$$\frac{2\frac{1}{2}}{4} \text{ means } 2\frac{1}{2} \div 4 \text{ or } \frac{5}{2} \times \frac{1}{4} \text{ or } \frac{5}{8}.$$

$$\frac{4\frac{1}{4}}{8} \text{ means } 4\frac{1}{4} \div 8 \text{ or } \frac{17}{4} \times \frac{1}{8} \text{ or } \frac{17}{32}.$$

$$\frac{\frac{1}{2}}{\frac{3}{16}} \text{ means } \frac{1}{2} \div \frac{3}{16} \text{ or } \frac{1}{2} \times \frac{16}{3} \text{ or } 2\frac{2}{3}.$$

Reduce each of these to simple fractions. Then perform the operations indicated:

1. Add  $\frac{1\frac{1}{4}}{4}$  to  $\frac{3\frac{1}{2}}{8}$
2. Subtract  $\frac{2\frac{2}{3}}{2}$  from  $\frac{\frac{1}{3}}{\frac{1}{2}}$

## 13. Ratio

(Without pencil.)

When two quantities are such that the first is twice the second they are said to be in the ratio of 2 to 1.

If the first quantity is three times the second, they are in the ratio of 3 to 1.

If the first is  $1\frac{1}{2}$  times the second they are in the ratio of 3 to 2.

1. State which of these pairs of numbers are in the ratio of 2 to 1.
2. State which of these pairs of numbers are in the ratio of 3 to 2.
3. State which of these pairs of numbers are in the ratio of 3 to 1.
  - a. 6 and 4
  - b. 10 and 5
  - c. 30 and 10
  - d. 1 and  $\frac{1}{2}$
  - e. 9 and 6
  - f. 9 and 3
  - g. 1 and  $\frac{1}{3}$
  - h.  $1\frac{1}{2}$  and 1
  - i. 6 and 3
  - j. 6 and 2
  - k. 30 and 20
  - l. 5 and  $2\frac{1}{2}$

\* Do not spend more than 10 minutes on this topic, unless the course of study of your school demands actual facility with complex fractions.



Hundred billions	Ten billions	Billions	Hundred millions	Ten millions	Millions	Hundred thousands	Ten thousands	Thousands	Hundreds	Tens	Ones	Tenths	Hundredths	Thousandths	Ten thousandths	Hundred thousandths	Millionths																			
<table style="width: 100%; border-collapse: collapse; text-align: center;"> <tr> <td style="border: 1px solid black; padding: 5px;">1</td> <td style="border: 1px solid black; padding: 5px;">0</td> <td style="border: 1px solid black; padding: 5px;">5</td> <td style="border: 1px solid black; padding: 5px;">7</td> <td style="border: 1px solid black; padding: 5px;">2</td> <td style="border: 1px solid black; padding: 5px;">6</td> <td style="border: 1px solid black; padding: 5px;">9</td> <td style="border: 1px solid black; padding: 5px;">2</td> <td style="border: 1px solid black; padding: 5px;">7</td> <td style="border: 1px solid black; padding: 5px;">6</td> <td style="border: 1px solid black; padding: 5px;">0</td> <td style="border: 1px solid black; padding: 5px;">0</td> <td style="border: 1px solid black; padding: 5px;">.</td> <td style="border: 1px solid black; padding: 5px;">0</td> <td style="border: 1px solid black; padding: 5px;">0</td> <td style="border: 1px solid black; padding: 5px;">5</td> <td style="border: 1px solid black; padding: 5px;">0</td> <td style="border: 1px solid black; padding: 5px;">0</td> <td style="border: 1px solid black; padding: 5px;">0</td> </tr> </table>																		1	0	5	7	2	6	9	2	7	6	0	0	.	0	0	5	0	0	0
1	0	5	7	2	6	9	2	7	6	0	0	.	0	0	5	0	0	0																		
<b>BILLIONS · MILLIONS · THOUSANDS · HUNDREDS · THE DECIMAL PLACES</b>																																				

1. Study the arrangement of names on this cyclometer.  
Begin at the decimal point and name the twelve places to the left. Then name them without looking at the book. Then begin at the decimal point and name the six places to the right. Then name them without looking at the book.
2. Name something that is worth about \$1000. About \$10,000. About \$100,000. About \$1,000,000. About \$10,000,000. About \$100,000,000. About \$1,000,000,000.
3. Name something that is worth about a tenth of a dollar. About one hundredth of a dollar. About \$.001. About \$.0001. About \$.00001.
4. 1 mile = 63,360 inches. How many inches are there in .1 mi.? In .01 mi.? In .001 mi.? In .0001 mi.? In .00001 mi.?
5. Read these numbers:\*

68.27

32.067

14.008

915.6

7.235

\* TO THE TEACHER.—“Sixty-eight, decimal point, two, seven,” “thirty-two, decimal point, zero, six, seven,” etc., are not only permissible but are probably preferable to “sixty-eight and twenty-seven hundredths,” etc., as readings of these numbers.

1. Write the products. You need not copy the multiplicands and multipliers.

<i>a.</i>	<i>b.</i>	<i>c.</i>	<i>d.</i>	<i>e.</i>	<i>f.</i>	<i>g.</i>	<i>h.</i>
15	1.5	15	1.5	7.5	7.5	.75	75
<u>1.5</u>	<u>1.5</u>	<u>.15</u>	<u>.15</u>	<u>2.1</u>	<u>.21</u>	<u>21</u>	<u>.21</u>

2. Check your result for *a* by thinking of 15 and half of 15.  
 3. Check your result for *b* by  $\frac{3}{2} \times \frac{3}{2}$ .  
 4. Check your result for *c* by  $\frac{15}{100} \times 15$ .  
 5. Compare the number of decimal places in each product with the number of decimal places in the multiplier and the multiplicand together.  
 6. Look at these products. Compare the number of decimal places in each product with the number of decimal places in the multiplier and the multiplicand together.

1.5	15	1.5	.15	7.5	7.5	.75	7.5
<u>.5</u>	<u>.05</u>	<u>.05</u>	<u>.05</u>	<u>3</u>	<u>.03</u>	<u>.06</u>	<u>.06</u>
.75	.75	.075	.0075	22.5	.225	.0450	.450

7. Write a rule for placing the decimal point in a product.  
 8. Use the rule in finding the products in *a*, *b*, *c*, *d*, etc., below.

<i>a.</i>	<i>b.</i>	<i>c.</i>	<i>d.</i>	<i>e.</i>	<i>f.</i>	<i>g.</i>
\$2.24	\$25.75	\$75	108 miles	\$75	\$8.25	1.624A.
<u>1.4</u>	<u>.06</u>	<u>.03</u>	<u>.41</u>	<u>.045</u>	<u>.05</u>	<u>21</u>
<i>h.</i>	<i>i.</i>	<i>j.</i>	<i>k.</i>	<i>l.</i>	<i>m.</i>	<i>n.</i>
\$50.00	2.71 lb.	\$.75	\$.0426	\$65	\$35.00	.062 in.
<u>.04</u>	<u>.15</u>	<u>.08</u>	<u>36</u>	<u>.035</u>	<u>.06</u>	<u>15</u>

25.75     *The product cannot be so much as 15.45.*  
.06     *For  $\frac{6}{100}$  is much less than  $\frac{1}{10}$ , and  $\frac{1}{10}$  of 25 is only 2.5.*  
15450     *The product cannot be so little as .1545.*  
           *For  $\frac{6}{100}$  is much more than  $\frac{1}{100}$ , and  $\frac{1}{100}$  of 25 is .25.*

## 16. Using Very Large Numbers

The values of certain farm crops raised in the United States were:

	In 1915	In 1900
Corn	\$1,755,859,000	\$751,220,000
Wheat	930,302,000	323,515,000
Oats	555,569,000	208,669,000

1. How much more was the 1915 crop of corn worth than the 1900 crop?
2. How much more was the 1915 crop of wheat worth than the 1900 crop?
3. How much more was the 1915 crop of oats worth than the 1900 crop?
4. What was the total value of these three crops in 1915?

The number of bushels of certain farm crops raised in the United States in 1895, 1905, and 1915 was:

	In 1915	In 1905	In 1895
Corn	3,054,535,000	2,707,994,000	2,151,139,000
Wheat	1,011,505,000	692,979,000	467,103,000
Oats	1,540,362,000	953,216,000	824,444,000
Barley	237,009,000	136,551,000	87,073,000
Rye	49,190,000	28,486,000	27,210,000

5. Without using pencil and paper, decide about how many times as much corn as wheat was grown in 1915. Was the number of bushels of corn about 2 times the number of bushels of wheat, or about  $2\frac{1}{2}$  times, or 3 times, or  $3\frac{1}{2}$  times, or 10 times, or 30 times?
6. Answer the same question for 1905. 7. For 1895.
8. Find the correct answers for 5, 6, and 7, to the first decimal place.
9. Without pencil and paper, decide about how many times as much corn as oats was grown in 1915.
10. In 1905. 11. In 1895.



12. Find the correct answers for 9, 10, and 11, to the first decimal place.
13. What was the increase in the corn crop from 1895 to 1905?
14. What was the increase in the corn crop from 1905 to 1915?
15. In which decade (a decade means 10 years) was the increase larger?
16. Find the numbers to fill this table:

	Number of Bushels Increase from 1895 to 1905	Number of Bushels Increase from 1905 to 1915
Wheat		
Oats		
Barley		
Rye		

17. In this country in 1915 farmers grew about 17 bushels of wheat to an acre. About how many acres were planted with wheat in 1915?
18. Which crops more than doubled from 1895 to 1915?
19. Which crops almost doubled from 1895 to 1915?
20. If the crops in 1935 are twice as large as the crops of 1915, what will be the number of bushels of each crop?
21. What other way is there of growing more wheat besides planting more acres of wheat?
22. Find the value of the wheat crop of a 40-acre field at 92¢ per bushel. (a) When 15 bu. are produced per acre. (b) When 25 bu. are produced per acre. (c) When 30 bu. are produced per acre.
23. Find the products:
  - a.  $1000 \times 5000$     b.  $900 \times 70,000$     c.  $9000 \times 700$
  - d.  $2000 \times 8000$     e.  $10,000 \times \$8.25$     f.  $700 \times 60,000$



142 17. Using Very Large and Very Small Numbers

1. Write the largest number that you can, using only six digits and a decimal point.
2. Write the smallest number that you can, using only six digits and a decimal point.
3. Estimate quickly how many seconds there are in a day.
4. Find out exactly how many there are.
5. If you received \$.0004 every second for an hour, how much would you receive in all?
6. A boy received \$.05 for working 25 minutes. How much did he receive per minute?
7. Check your result for Ex. 6 by multiplying the quotient by the divisor.
8. Find the sum of \$284,095,000, \$761,260,000, and \$54,932,000.
9. Find the sum of .015, .04034, and .12.
10. Find the sum of .0418, .0392, .0437, and .0426.
11. If one sheet of paper was .035 in. thick, how thick would a book of 236 pages or 118 sheets (without covers) be?
12. If one sheet of paper was .00035 in. thick how thick would such a book be?
13. Estimate how thick one sheet of paper like this is.
14. Find out just how thick it is, counting that 128 sheets are .448 in. thick.  
$$128 \overline{) .448}$$
15. How do you know that one sheet cannot be as thick as .035 in.?
16. How do you know that one sheet cannot be as thin as .00035 in.?

In dividing a decimal by an integer, place the decimal point in the quotient above the decimal point in the dividend.

17. Show that this rule is correct by using it in these four problems and checking the results by multiplying:
- a.  $15\overline{)31.5}$       b.  $13\overline{).416}$       c.  $21\overline{).903}$       d.  $25\overline{).0775}$
18. (a) How many pairs of shoes have to be made each year for 92,426,000 persons if each one has an average of 3 pairs of shoes a year?
- (b) How many pins have to be made each year if each of the 92,426,000 persons uses an average of 136 pins a year?
19. If 250 pins cost \$.05 what is the exact cost of one pin?
20. Check your result for Ex. 19 by multiplying.
21. If you buy a pound of nails for 3 cents, and there are 89 nails in a pound, what is the cost of one nail to the nearest hundredth of a cent, or ten-thousandth of a dollar, or fourth decimal place?
- $\begin{array}{r} .0003 \\ 89\overline{).0300} \\ \underline{267} \\ 33 \end{array}$       *Since the remainder (33) is less than half the divisor, the quotient to the fourth decimal place is \$.0003.*
22. If you buy 24 sheets of writing paper for 5 cents, what is the cost per sheet to the nearest ten-thousandth of a dollar? (Use \$.05 for 5 cents.)
23. At 2¢ for a package of 24 hairpins, what is the cost for one hairpin? (Use \$.02 and find the quotient to the fourth decimal place.)
24. Two hundred years ago, it cost Lucy's great-great-great-great-grandfather 32 cents per mile to send a load to the city. Lucy's father can send the same load the same distance in a motor truck at a cost of 3 cents per mile. How many times as much as now did it cost 200 years ago? (Use  $3\overline{)32.000}$ , finding the result to the third decimal place.)

## 18. Finding Approximate Costs

Find the cost for one article to the nearest tenth of a cent, or thousandth of a dollar, or third decimal place —

1. When you get 15 for 50 cents.                      2. When you get 18 for 25 cents.

$$\begin{array}{r} \$.033^5/15 \\ 15 \overline{) \$.500} \\ \underline{45} \\ 50 \\ \underline{45} \\ 5 \end{array}$$

*\$.033 to the nearest thousandth of a dollar.*

$$\begin{array}{r} \$.013^{16}/18 \\ 18 \overline{) \$.250} \\ \underline{18} \\ 70 \\ \underline{54} \\ 16 \end{array}$$

*\$.014 to the nearest thousandth of a dollar.*

Find the cost for one article to the nearest thousandth of a dollar—

3. When you get 12 articles for 40 cents.
4. When you get 12 articles for 50 cents.
5. When you get 3 articles for a dollar.
6. When you get 6 articles for 25 cents.
7. When you get 6 articles for 5 cents.
8. When you get 24 articles for 75 cents.
9. When you get 12 articles for 89 cents.
10. When you get 12 articles for 43 cents.

Find the cost for one article to the nearest hundredth of a dollar —

11. When you get 25 articles for 98¢.
12. When you get 15 articles for 25¢.
13. When you get 12 articles for 30¢.
14. What is the cost for one article to the nearest cent or hundredth of a dollar in Ex. 1?    15. In Ex. 2?

Find the quotients to the nearest thousandth of a mile —

16. When you divide 19.7 mi. by 8.
17. When you divide 25 mi. by 9.



(Without pencil.)

1. What is the cost for one article when you get 10 for \$1.00?
2. When you get 10 for \$2.00?    3. When you get 10 for \$2.75?
4. When you get 10 for \$.25?    5. When you get 10 for \$.01?
- When you get—
6. 10 for \$.05?    7. 10 for \$.15?    8. 10 for \$12.75?    9. 10 for \$.03?

To divide by 10 move the decimal point one place to the left, inserting 0 if necessary.

10. How much is  $\frac{1}{10}$  of 25.8 inches?     $\frac{1}{10}$  of 46 minutes?  
 $\frac{1}{10}$  of 20.8 ft.?
11. How much is  $\frac{1}{10}$  of 60 ft.?     $\frac{1}{10}$  of 55 ft.?     $\frac{1}{10}$  of 11 mi.?  
 $\frac{1}{10}$  of 9 mi.?     $\frac{1}{10}$  of .06 mi.?     $\frac{1}{10}$  of .8 mi.?     $\frac{1}{10}$  of 500?  
.1  $\times$  .5?    .1  $\times$  7?    .1  $\times$  .04?    .6  $\div$  10?    9  $\div$  10?  
.03  $\div$  10?

You may think of 5 as 005.00    23 as 0023.00    125 as 00125.00  
6 as 006.00    38 as 0038.00    246 as 00246.00

12. Find the cost per article when you get 100 for \$2.00.
13. When you get 100 for \$.50.    14. When you get 100 for \$200.00.    15. When you get 100 for \$100.00.    16. For \$1.00.    17. For \$119.75.
18. How many places to the left do you move the decimal point to divide by 100?
19. How far is  $\frac{1}{100}$  of 153.7 miles?    20.  $\frac{1}{100}$  of 1000 miles?
21. How many lbs. =  $\frac{1}{100}$  of a ton?    22.  $\frac{1}{100}$  of 168.75 lb.?
23. How many ft. =  $\frac{1}{100}$  of 826.4 ft.?    24.  $\frac{1}{100}$  of 5280 ft.?
25. Tell what happens to each hundred, ten, one, tenth, etc., when the decimal point is moved *two places* to the left.
26. Tell what happens to each hundred, ten, one, tenth, etc., when the decimal point is moved *one place* to the right.



## 20. Finding Exact Costs

1. Robert lives in the city, but he likes to make things grow, and has a garden every year. Last year he sold 234 ears of corn, receiving in all \$5.40. How much did he receive per ear? Find the answer to the nearest tenth of a cent or thousandth of a dollar.

$$\begin{array}{r}
 \$.023 \\
 234 \overline{) \$5.400} \\
 \underline{468} \\
 720 \\
 \underline{702} \\
 18
 \end{array}$$

*Annex 0 to the \$5.40 and continue dividing.*

*\$.023 is right; for  $\frac{18}{234}$  is less than  $\frac{1}{2}$ .*

2. How do you know that the amount is not so large as \$.23?
3. How do you know that the amount is not so small as \$.0023?
4. Robert figured out just how much it cost to grow each ear of corn, counting the total cost for the 234 ears as \$4.25. What was the cost per ear of corn to the nearest hundredth of a cent or ten-thousandth of a dollar?
5. How do you know that it did not cost him as much as \$.18 per ear?
6. How do you know that it did not cost him as little as \$.0018 per ear?
7. Of the \$4.25, \$1.45 was for the rent of the land, seed, fertilizer, and wear and tear on tools. The rest was for labor. What was the cost for labor?
8. Robert charged 8 cents per hour for his labor. For how many hours did he charge? (Use your result for Ex. 7.)
9. It cost Robert \$4.25 to grow the corn. He figures that it cost him 9 hours labor in selling the corn. Counting the labor of selling the corn at 8 cents an hour, what was the total cost of growing and selling the 234 ears?

1. Lucy keeps hens. She reckons that it costs her \$28.75 to feed fifteen hens for a year, besides the scraps she gets from her mother and some neighbors. How much does it cost for one hen for a year?
2. She reckons that she spent in all last year 430 hours in taking care of the hens and selling the eggs. What was her average time spent per day? Find it to the nearest hundredth of an hour.
3. If she paid for labor at 6 cents an hour, how much would the cost for labor be for caring for the 15 hens for a year and selling the eggs?
4. Last year she got 2680 eggs from the fifteen hens. What was the average number of eggs per hen?
5. Not counting anything for her time and labor, she reckons the total cost of the 2680 eggs at \$41.25. How much is the cost per egg (to the nearest tenth of a cent)?
6. She sold 10 dozen eggs at 22¢ per dozen.  
She sold 20 dozen eggs at 24¢ per dozen.  
She sold 20 dozen eggs at 28¢ per dozen.  
She sold 40 dozen eggs at 30¢ per dozen.  
She sold 34 dozen eggs at 32¢ per dozen.  
She sold 35 dozen eggs at 34¢ per dozen.  
She sold 30 dozen eggs at 36¢ per dozen.  
She sold 20 dozen eggs at 40¢ per dozen.  
She sold 10 dozen eggs at 45¢ per dozen.  
She sold  $4\frac{1}{3}$  dozen eggs at 48¢ per dozen.  
How much did she receive in all for the eggs?
7. After paying \$41.25 for expenses, how much did she have left to repay her for her time and labor?
8. How much did she get per hour for the 430 hours that she worked in caring for the hens and selling the eggs?

148 22. Expressing Common Fractions as Decimal Numbers

Express each of these common fractions as a decimal to the third decimal place. Write the remainders as shown in *a* and *b*. Also write the result to the nearest thousandth.

a.  $\frac{5}{32} = .156\frac{1}{4}$  or  $.156$

$$\begin{array}{r} .156\frac{8}{32} \\ 32 \overline{)5.000} \\ \underline{32} \\ 180 \\ \underline{160} \\ 200 \\ \underline{192} \\ 8 \end{array}$$

b.  $\frac{1}{64} = .015\frac{5}{8}$  or  $.016$

$$\begin{array}{r} .015\frac{40}{64} \\ 64 \overline{)1.00} \\ \underline{64} \\ 360 \\ \underline{320} \\ 40 \end{array}$$

1.  $\frac{7}{32}$     2.  $\frac{5}{9}$     3.  $\frac{1}{16}$     4.  $\frac{5}{12}$     5.  $\frac{6}{7}$     6.  $\frac{29}{64}$     7.  $\frac{5}{6}$     8.  $\frac{9}{16}$   
 9.  $\frac{2}{3}$     10.  $\frac{11}{24}$     11.  $\frac{2}{7}$     12.  $\frac{7}{18}$     13.  $\frac{1}{75}$     14.  $\frac{7}{12}$     15.  $\frac{1}{32}$     16.  $\frac{7}{8}$

23. Expressing Decimal Numbers as Common Fractions or Mixed Numbers

(Use pencil only if you need to.)

1. Express each of these decimals as a common fraction or mixed number:

A.	B.	C.	D.	E.
.5	$.33\frac{1}{3}$	$.37\frac{1}{2}$	$.83\frac{1}{3}$	.875
.75	$.12\frac{1}{2}$	$.62\frac{1}{2}$	$.87\frac{1}{2}$	.125
$.16\frac{2}{3}$	.25	$.66\frac{2}{3}$	$.833\frac{1}{3}$	$.62\frac{1}{2}$
.625	.375	$.333\frac{1}{3}$	$.166\frac{2}{3}$	.500

2. Express each of these common fractions as a decimal. Learn those which you do not already know perfectly.

$$\begin{array}{cccccccc} \frac{1}{4} & \frac{1}{2} & \frac{3}{4} & \frac{1}{5} & \frac{2}{5} & \frac{1}{8} & \frac{3}{8} & \frac{5}{8} \\ \frac{7}{8} & \frac{1}{6} & \frac{1}{3} & \frac{2}{3} & \frac{5}{6} & \frac{1}{20} & \frac{1}{25} & \frac{1}{12} \end{array}$$

3. Express each decimal as a common fraction and tell the products:

$$\begin{array}{cccc} .125 \times 24 & .625 \times 16 & .33\frac{1}{3} \times 300 & .37\frac{1}{2} \times 8 \\ .16\frac{2}{3} \times 90 & .83\frac{1}{3} \times 12 & .875 \times 32 & .25 \times 72 \end{array}$$

What is the exact area of a rectangular field  $391\frac{3}{4}$  ft. long and  $271\frac{1}{2}$  ft. wide?

*You can find the area by expressing the numbers as improper fractions or as decimals like this:*

$$4 \times 391 = 1564$$

$$1564 + 3 = 1567$$

$$2 \times 271 = 542$$

$$542 + 1 = 543$$

$$\frac{1567}{4} \times \frac{543}{2}$$

$$391.75$$

$$\underline{271.5}$$

1. Find the answer, using the first way.
2. Then check your result, using the second way.

Find the products. Use the way that you like best:

3.  $186\frac{1}{4} \times 173\frac{1}{2}$     4.  $91\frac{1}{2} \times 110\frac{3}{4}$     5.  $61\frac{1}{2} \times 73\frac{1}{4}$

(Without pencil.)

6. Perform the operations indicated and state the results.

A.	B.	C.	D.
$4 \times 8$	$10 \times 12.5$	$12.8 \div 10$	$.16 - .08$
$.4 \times 8$	$100 \times 1.035$	$3.65 \div 10$	$.16 + .08$
$.04 \times 8$	$100 \times .045$	$385.5 \div 100$	$.7 \times .9$
$6 \times .9$	$10 \times 27.50$	$675 \div 100$	$1.25 \div 5$
$.06 \times 20$	$1000 \times 6$	$\$85 \div 100$	$4.00 \div 5$
$.06 \times 25$	$1000 \times .6$	$\$9.75 \div 10$	$2.4 \div 8$
$.05 \times 15$	$1000 \times .06$	$.20 - .07$	$.63 \div 9$
$.05 \times 100$	$100 \times .045$	$.05 + .09$	$4.2 \div 6$
$.05 \times 700$	$10 \times .65$	$.08 + .009$	$.42 \div 6$
$.05 \times 250$	$10 \times .03$	$.8 \times .8$	$.04 \times 800$

7. Express each of these fractions as a decimal:

$$\frac{1}{8} \quad \frac{1}{6} \quad \frac{1}{5} \quad \frac{1}{4} \quad \frac{1}{3} \quad \frac{2}{3} \quad \frac{2}{5} \quad \frac{3}{8} \quad \frac{5}{8} \quad \frac{7}{8}$$

8. Tell what part of a dollar each of these is:

$$12\frac{1}{2}\text{¢} \quad 16\frac{2}{3}\text{¢} \quad 20\text{¢} \quad 25\text{¢} \quad 33\frac{1}{3}\text{¢} \quad 37\frac{1}{2}\text{¢} \quad 40\text{¢} \quad 66\frac{2}{3}\text{¢}$$



## 25. Dividing by a Decimal

In most countries length is not measured in feet and inches, but in meters and centimeters.

1 meter (or 1 m.) = 39.37 inches or 3.281 ft.

1 centimeter (or 1 cm.) = .3937 in.

1. Which is longer, a meter or a yard? How much longer?
2. How many inches long is a 3-meter pole?
3. How many centimeters are there in a foot? (Find the quotient to the second decimal place.)

Use

$$.3937 \overline{)12.000000}$$

or

use

$$3937 \overline{)120000.00}$$

Remember that

Divisor  $\times$  quotient must = dividend

Number of decimal places in divisor +

number of decimal places in the quotient must equal  
number of decimal places in the dividend.

4. Check your result for Ex. 3 by thinking of .3937 as almost  $\frac{4}{10}$  or  $\frac{2}{5}$  and dividing 12 by  $\frac{2}{5}$ .
5. 1 kilometer = 1000 meters. How many feet long is 1 kilometer?
6. How many kilometers equal 1 mile?
7. Which is nearer to 1 mile,  $1\frac{5}{8}$  km. or 1.6 km.?
8. Divide 3281 by 5280 (extending the quotient to the third decimal place). What does the quotient tell about a mile and a kilometer?
9. Which is nearest to 1 kilometer, .62 mi. or .63 mi.?
10. Which is longer, 10 kilometers or 6 miles?
11. Tell where the decimal point should be put in each of these quotients. Prefix zeros where they are needed as is done in the first line.

$$a. \begin{array}{r} 62 \\ .45 \overline{)27.90} \end{array} \quad b. \begin{array}{r} 3150 \\ .006 \overline{)18.900} \end{array} \quad c. \begin{array}{r} 006 \\ .875 \overline{).0525} \end{array} \quad d. \begin{array}{r} 041 \\ 39.37 \overline{)1.61417} \end{array}$$

$$e. \overset{36}{.05} \overline{) .18} \quad f. \overset{475}{.045} \overline{) 2.1375} \quad g. \overset{45}{21.5} \overline{) 9.675} \quad h. \overset{5180}{.04} \overline{) 207.2}$$

12. At \$.0136 a day, how long can you feed a hen for \$1.00?  
Find the answer to the nearest whole day.
13. How many wire springs, each requiring 1.6 in. of wire, can be cut from a 100-ft. length of wire?

## 26.

1. Examine the two ways of finding the quotient of  $213\frac{7}{8}$  divided by  $4\frac{3}{4}$ .

$$\begin{array}{r} 213 \\ 8 \\ \hline 1704 \\ 7 \\ \hline 1711 \end{array} \quad \frac{1711}{8} \times \frac{4}{19} = \frac{1711}{38}$$

$$\begin{array}{r} .875 \\ 8 \overline{) 7.000} \end{array}$$

$$\begin{array}{r} 45.026 \\ 4.75 \overline{) 213.87500} \\ \underline{190 \phantom{0}} \\ 2387 \\ \underline{2375} \\ 1250 \\ \underline{950} \\ 3000 \\ \underline{2850} \end{array}$$

$$\begin{array}{r} 45.026 \\ 38 \overline{) 1711.000} \\ \underline{152} \\ 191 \\ \underline{190} \\ 100 \\ 76 \\ \underline{240} \\ 228 \end{array}$$

With large numbers the second way is generally used.

2. Find the quotients. Express the numbers as decimals and divide. Do not continue dividing beyond three decimal places in the quotient.

a.	b.	c.	d.
$175\frac{3}{8} \div 9\frac{1}{2}$	$368\frac{3}{4} \div 7\frac{1}{8}$	$45\frac{3}{4} \div 3\frac{6}{10}$	$528\frac{1}{2} \div 8\frac{2}{3}$ (use 8.67)
e.	f.	g.	h.
$250\frac{1}{4} \div 6\frac{2}{5}$	$575 \div 2\frac{3}{4}$	$14\frac{5}{8} \div 3\frac{1}{2}$	$320 \div 1\frac{3}{4}$

## 27. Earning Money

1. John collects rent money for his father. His father pays John  $.02 \times$  what he collects. Say the missing numbers:
- |    |          |                |         |              |              |         |      |
|----|----------|----------------|---------|--------------|--------------|---------|------|
| a. | Feb. 1-7 | John collected | \$12.00 | and was paid | $.02 \times$ | \$12.00 | or.. |
| b. | 8-14     | " "            | 25.00   | " " "        | $.02 \times$ | \$25.00 | or.. |
| c. | 15-21    | " "            | 7.50    | " " "        | $.02 \times$ | 7.50    | or.. |
| d. | 22-28    | " "            | 12.50   | " " "        | $.02 \times$ | 12.50   | or.. |
| e. | Mar. 1-7 | " "            | 21.00   | " " "        | $.02 \times$ | 21.00   | or.. |
| f. | 8-14     | " "            | 14.50   | " " "        | $.02 \times$ | 14.50   | or.. |
2. Helen makes out the bills for milk and cream, and collects the money from her father's customers. Her father pays her  $.035 \times$  what she collects. How much does he pay her in each of these months?
- |    |      |                    |          |              |               |          |       |       |
|----|------|--------------------|----------|--------------|---------------|----------|-------|-------|
| a. | Jan. | Helen collected \$ | 98.40    | and was paid | $.035 \times$ | \$       | 98.40 | or... |
| b. | Feb. | " "                | \$107.60 | " " "        | $.035 \times$ | \$107.60 | or... |       |
| c. | Mar. | " "                | \$102.00 | " " "        | $.035 \times$ | \$102.00 | or... |       |
3. Fred sells goods in a store. He is paid \$3.75 a week and  $.03 \times$  what he sells. How much is he paid in all:
- For a week when he sells \$85.00 worth of goods?
  - For a week when he sells \$100.00 worth of goods?
  - For a week when he sells \$130.00 worth of goods?

## 28. Practice with Decimal Numbers

*(Without pencil.)*

1. State as many products as you can in 2 minutes, without making a mistake. Then try again. How much did you improve?

A.	B.	C.	D.
$.04 \times \$15.00$	$.06 \times \$100$	$.03 \times \$1000$	$.10 \times \$2.50$
$.03 \times \$40.00$	$.05 \times \$500$	$.05 \times \$2000$	$.04 \times \$2.50$
$.10 \times \$7.50$	$.20 \times \$10$	$.02 \times \$7000$	$.03 \times \$2.50$
$.25 \times \$20.00$	$.50 \times \$4.50$	$.75 \times \$4$	$.33\frac{1}{3} \times \$7.50$
$.06 \times \$12.00$	$.16\frac{2}{3} \times \$12$	$.06 \times \$1000$	$.12\frac{1}{2} \times \$2.00$
$.04 \times \$25.00$	$.25 \times \$5.00$	$.66\frac{2}{3} \times \$18$	$.05 \times \$1.00$

To multiply by .1 move the decimal point one place to the left. Prefix 0 if necessary.

To multiply by .01 move the decimal point two places to the left. Prefix 0 or 00 if necessary.

2. Explain these rules by supplying the missing words:  
 Multiplying by .1 is the same as dividing by .....  
 Moving the decimal point one place to the left makes every 1 a ....., every 10 a ....., and every 100 a ..... Multiplying by .01 is the same as dividing by ..... Moving the decimal point two places to the left makes every 1 a ....., every 100 a ....., and every 1000 a .....
3. Make a rule for multiplying by .001.
4. Using these rules, state the products of:
- |                                 |                                |                         |
|---------------------------------|--------------------------------|-------------------------|
| a. $.01 \times \$8.50$          | d. $.1 \times 60 \text{ min.}$ | g. $.001 \times 928.4$  |
| b. $.001 \times 6500$           | e. $.01 \times \$25$           | h. $.01 \times \$48.00$ |
| c. $.01 \times 725 \text{ ft.}$ | f. $.01 \times \$900$          | i. $.01 \times \$6.00$  |

*People usually say "percent of" for "hundredths times."*

*1 percent of \$20 means  $.01 \times \$20$*

*2 percent of \$10 means  $.02 \times \$10$*

*3 percent of \$50 means  $.03 \times \$50$*

*4 percent of \$8 means  $.04 \times \$8$*

5. How much is 2 percent of \$16 or  $.02 \times \$16$ ?
6. How much is 5 percent of \$30 or  $.05 \times \$30$ ?
7. How much is 6 percent of \$200 or  $.06 \times \$200$ ?
8. Find the products:
- |                         |                         |
|-------------------------|-------------------------|
| a. 3 percent of \$100 = | f. 2 percent of \$100 = |
| b. 3 percent of \$400 = | g. 8 percent of \$100 = |
| c. 6 percent of \$300 = | h. 7 percent of \$100 = |
| d. 7 percent of \$300 = | i. 4 percent of \$100 = |
| e. 5 percent of \$700 = | j. 5 percent of \$100 = |



## 29. A Multiplication Ladder

Here is a multiplication ladder. Begin at the bottom and climb to the top. Find the products. Express any common fractions or mixed numbers in your results in lowest terms.

Step 11. a.  $.65 \times 104.7$  mi.    b.  $.625 \times \$10.50$   
           c.  $.0325 \times \$103.25$     d.  $3\frac{5}{8} \times 4.6$     e.  $.0426 \times 10904$

Step 10. a.  $90.04 \times \$925.00$     b.  $.035 \times \$103.50$   
           c.  $.75 \times \$1.20$     d.  $.15 \times 39.37$     e.  $.06 \times \$5$

Step 9. a.  $12 \times \$\frac{5}{8}$     b.  $24 \times 16\frac{2}{3}\text{¢}$     c.  $36 \times 12\frac{1}{2}\text{¢}$   
           d.  $8 \times 87\frac{1}{2}\text{¢}$     e.  $\frac{3}{4} \times 1\frac{2}{3}$

Step 8. a.  $9 \times 1\frac{1}{8}$     b.  $5\frac{1}{2} \times 3\frac{1}{2}$     c.  $25\frac{1}{2} \times \$120$   
           d.  $16\frac{3}{4} \times \$500$     e.  $7\frac{1}{2} \times 11\frac{3}{4}$

Step 7. a.  $3\frac{1}{2} \times \$1.50$     b.  $7\frac{1}{4} \times \$1.25$     c.  $5\frac{3}{8} \times \$1.00$   
           d.  $4\frac{3}{4} \times 144$     e.  $2\frac{1}{3} \times \$1.00$

Step 6. a.  $\frac{3}{4} \times 10$     b.  $\frac{2}{3} \times 8$     c.  $\frac{7}{8} \times 5$     d.  $15 \times \frac{3}{5}$   
           e.  $\frac{3}{4} \times \frac{3}{4}$ .

Step 5. a.  $\begin{array}{r} 3.07 \\ \underline{60} \end{array}$     b.  $\begin{array}{r} 57.5 \\ \underline{40} \end{array}$     c.  $\begin{array}{r} 6.14 \\ \underline{5.03} \end{array}$     d.  $\begin{array}{r} 530 \\ \underline{4.6} \end{array}$     e.  $\begin{array}{r} 30.9 \\ \underline{40.7} \end{array}$

Step 4. a.  $\begin{array}{r} 605 \\ \underline{20} \end{array}$     b.  $\begin{array}{r} 225 \\ \underline{20} \end{array}$     c.  $\begin{array}{r} 214 \\ \underline{102} \end{array}$     d.  $\begin{array}{r} 850 \\ \underline{27} \end{array}$     e.  $\begin{array}{r} 908 \\ \underline{506} \end{array}$

Step 3. a.  $\begin{array}{r} 9.3 \\ \underline{2.1} \end{array}$     b.  $\begin{array}{r} \$2.47 \\ \underline{16} \end{array}$     c.  $\begin{array}{r} 74 \\ \underline{.32} \end{array}$     d.  $\begin{array}{r} 1.24 \\ \underline{1.7} \end{array}$     e.  $\begin{array}{r} 3.18 \\ \underline{5} \end{array}$

Step 2. a.  $\begin{array}{r} 43 \\ \underline{15} \end{array}$     b.  $\begin{array}{r} 27 \\ \underline{29} \end{array}$     c.  $\begin{array}{r} 52 \\ \underline{38} \end{array}$     d.  $\begin{array}{r} 75 \\ \underline{17} \end{array}$     e.  $\begin{array}{r} 84 \\ \underline{46} \end{array}$

Step 1. a.  $\begin{array}{r} 62 \\ \underline{7} \end{array}$     b.  $\begin{array}{r} 94 \\ \underline{8} \end{array}$     c.  $\begin{array}{r} 73 \\ \underline{6} \end{array}$     d.  $\begin{array}{r} 85 \\ \underline{9} \end{array}$     e.  $\begin{array}{r} 48 \\ \underline{5} \end{array}$

## 30. A Division Ladder

Begin at the bottom of the division ladder and climb to the top without making a mistake. Express any common fractions or mixed numbers in your results in lowest terms.

- Step 11.** Find quotients to the third decimal place:  
*a.*  $39.37 \overline{)80}$     *b.*  $11.25 \overline{)6}$     *c.*  $360 \overline{).50}$     *d.*  $293\frac{7}{8} \div 61.5$
- Step 10.** Find exact quotients:  
*a.*  $2.5 \overline{)1200}$     *b.*  $.25 \overline{)3.55}$     *c.*  $.045 \overline{)20.25}$     *d.*  $.05 \overline{)42.3}$
- Step 9.** *a.*  $6\frac{3}{4} \div \frac{3}{4}$     *b.*  $\frac{1}{4} \div \frac{3}{8}$     *c.*  $10\frac{1}{2} \div \frac{7}{8}$     *d.*  $1\frac{3}{4} \div \frac{1}{2}$     *e.*  $\frac{3}{4} \div \frac{1}{8}$
- Step 8.** Find the missing numbers:  
*a.*  $\$10 = \dots \times 66\frac{2}{3}\text{¢}$     *b.*  $\$25 = \dots \times 16\frac{2}{3}\text{¢}$     *c.*  $\$5 = \dots \times 62\frac{1}{2}\text{¢}$   
*d.*  $\$50 = \dots \times 75\text{¢}$     *e.*  $\$10 = \dots \times 37\frac{1}{2}\text{¢}$
- Step 7.** Find quotients to the third decimal place:  
*a.*  $19 \overline{)390.6}$     *b.*  $13 \overline{)400}$     *c.*  $14 \overline{)859.15}$     *d.*  $35 \overline{)2941}$     *e.*  $45 \overline{)180.135}$
- Step 6.** Find exact quotients as integers or mixed numbers. Do not extend quotients to any decimal places.  
*a.*  $36 \overline{)1000}$     *b.*  $18 \overline{)725}$     *c.*  $24 \overline{)2000}$     *d.*  $16 \overline{)2500}$     *e.*  $17 \overline{)6075}$
- Step 5.** Find exact quotients:  
*a.*  $3 \overline{)5 \text{ hr. } 9 \text{ min.}}$     *b.*  $4 \overline{)10 \text{ ft. } 8 \text{ in.}}$     *c.*  $5 \overline{)8 \text{ lb. } 2 \text{ oz.}}$     *d.*  $5 \overline{)2 \text{ lb. } 3 \text{ oz.}}$
- Step 4.** Find quotients and remainders. Do not extend quotients to any decimal places.  
*a.*  $7 \overline{)1499}$     *b.*  $9 \overline{)6310}$     *c.*  $8 \overline{)6458}$     *d.*  $6 \overline{)28236}$     *e.*  $5 \overline{)2705}$
- Step 3.** Find quotients to the nearest cent:  
*a.*  $5 \overline{)\$10.40}$     *b.*  $7 \overline{)\$25.75}$     *c.*  $9 \overline{)\$15.00}$     *d.*  $8 \overline{)\$36.00}$     *e.*  $6 \overline{)\$10.00}$
- Step 2.** Find quotients as integers or mixed numbers. Do not extend quotients to any decimal places.  
*a.*  $20 \overline{)740}$     *b.*  $80 \overline{)1375}$     *c.*  $40 \overline{)7500}$     *d.*  $90 \overline{)72000}$     *e.*  $30 \overline{)965}$
- Step 1.** Find quotients and remainders. Do not extend quotients to any decimal places.  
*a.*  $3 \overline{)196}$     *b.*  $4 \overline{)215}$     *c.*  $5 \overline{)92}$     *d.*  $7 \overline{)252}$     *e.*  $6 \overline{)127}$

## 31. Working Drawings

1. To make a man's handkerchief, medium size, a piece of cloth  $\frac{1}{2}$  yd. long and  $\frac{1}{2}$  yd. wide is taken.



$\frac{1}{4}$  in. is turned for a hem all around the edge. (a) How long and how wide will the handkerchief be? (b) If the handkerchief is folded across the middle four times so as to look like the picture, just how long and how wide is the space it covers?

2. We will plan a handkerchief box for father's handkerchiefs, that will be big enough so that he can put a handkerchief in or take one out easily. How long is the bottom of the box to be, as shown in the plan?

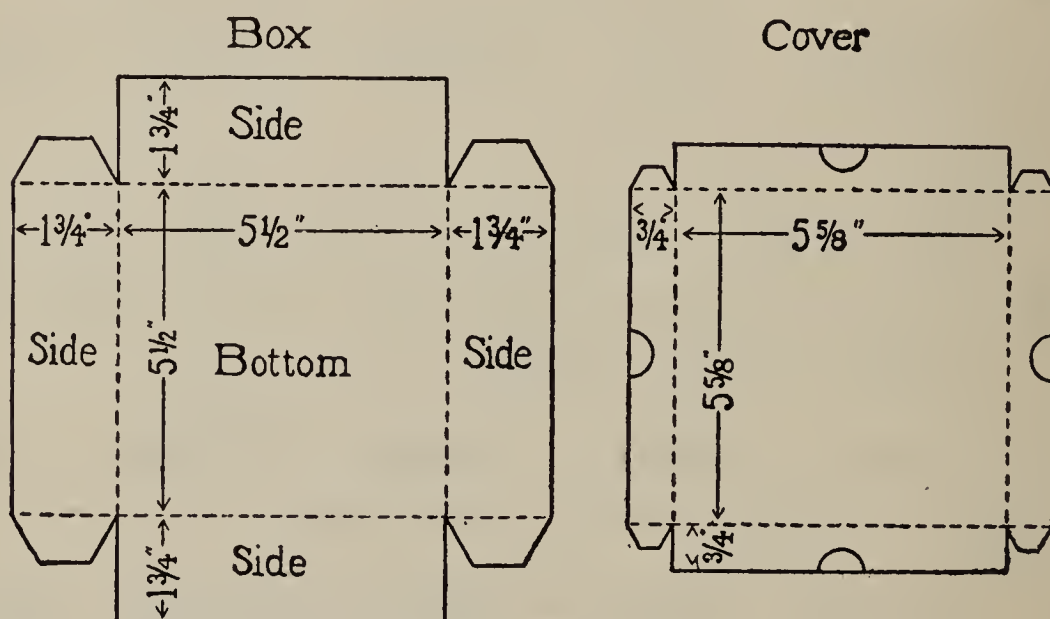

3. How large a piece of paper is needed to make the bottom and sides of the box?
4. The top of the cover is made a little larger than the box itself so that the cover will go on and off easily. How much larger is it made?
5. How large a piece of paper is needed to make the cover?
6. How many cubic inches will a box contain which is  $8\frac{1}{4}$  in. long,  $3\frac{1}{2}$  in. wide, and 2 in. deep?

1. Examine this map. It is a map of a township. The numbers on it are the numbers of the sections into which it is divided. Consider the township as a square and each section as a square.

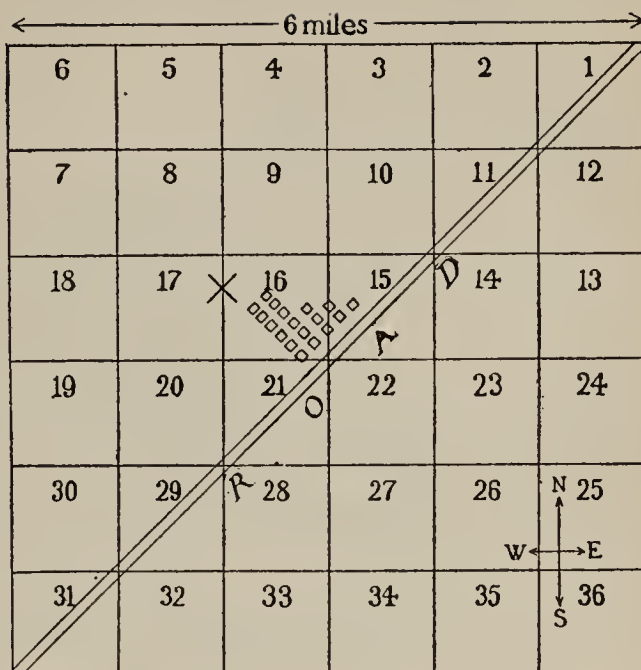

2. How many square miles are there in the township?
3. How many acres are there in a quarter of a section?
4. What fraction of a section is 80 acres?
5. How many acres are there in the whole township?
6. 210 acres of this township are in village lots. The rest is in farms. How many acres are in farms?
7. There are 108 farms. What is the average number of acres per farm?
8. The cross shows the location of the largest school in this township. It is on the edge between section 16 and section 17, exactly .4 mile south of the corner of sections 8, 9, 16, and 17. How far is it (by the nearest straight line) from the north edge of the township?
9. How far is it (by the nearest straight line) to the south edge?
10. From one corner to the opposite corner of a section is 1.414 mi. How long is the road shown running across the township?
11. The population of the whole township was 945. What was the average population per square mile?



Map of United States

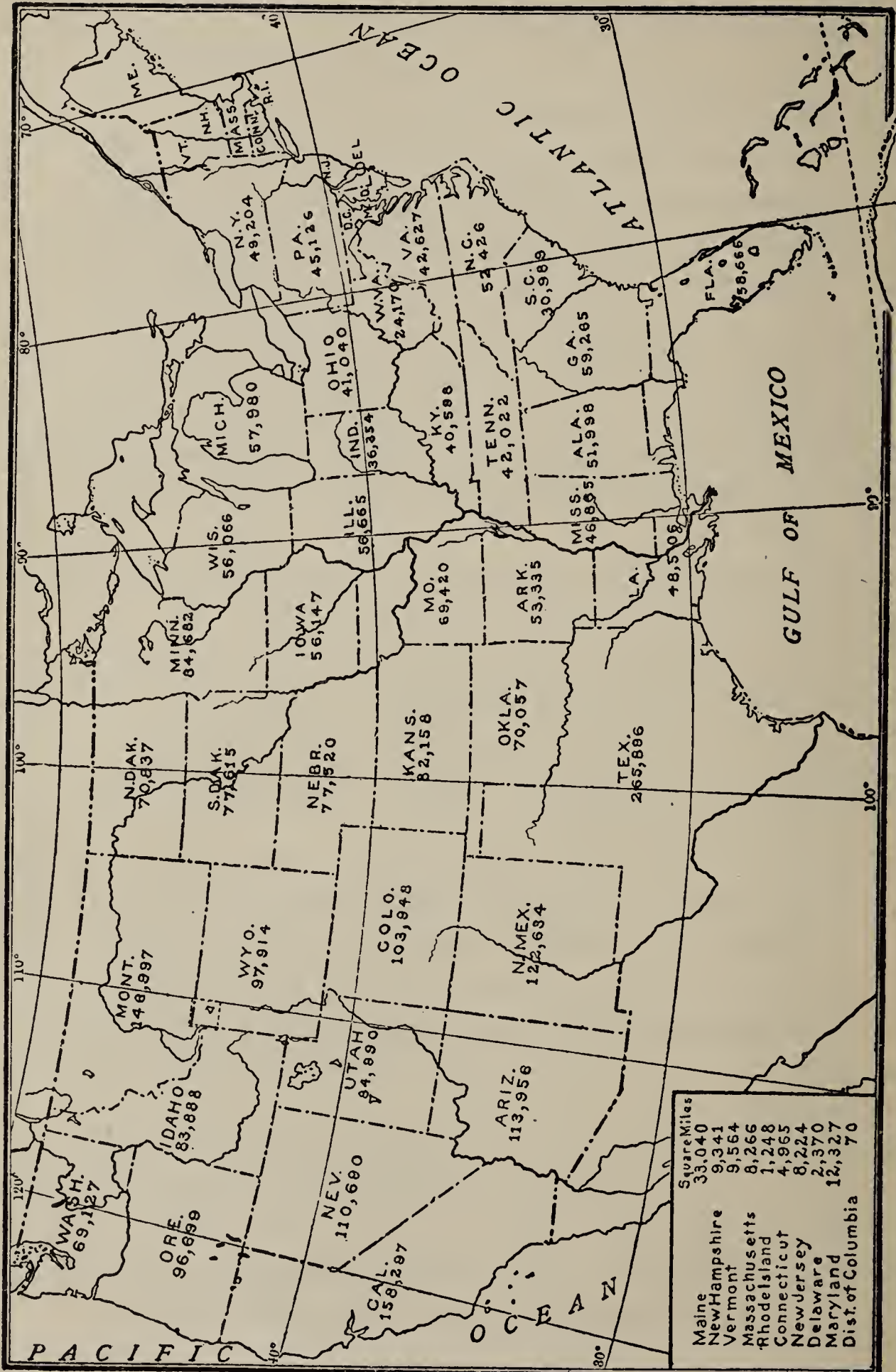

State	Area (Square Miles)
Maine	33,040
New Hampshire	9,341
Vermont	9,564
Massachusetts	8,266
Rhode Island	1,248
Connecticut	4,965
New Jersey	8,224
Delaware	2,370
Maryland	12,327
Dist. of Columbia	70

Copyright, 1917, by Rand McNally & Company

1. Write the names of any 5 states that you know and estimate the number of square miles that you think each contains. Then look at the map and table on p. 158 and find out how near you came in each case.
2. Look at the map, covering up the table, and estimate how many square miles there are in each of these states, in the northeast corner of the United States: (a) Maine, (b) N. H. (New Hampshire), (c) Vt. (Vermont), (d) Mass. (Massachusetts). Then examine the table and find out how near your estimate was to the true area in each case.
3. Look at the map and estimate what each of these missing numbers should be:
  - a. Texas is . . . times as large as S. Carolina.
  - b. Texas is . . . times as large as N. Carolina.
  - c. Texas is . . . times as large as New York.
  - d. Texas is . . . times as large as Vt. and N. H. together.Then find the correct missing numbers. Extend the quotients only to the second decimal place.
4. How many times as large as your state is Texas?
5. How many times as large as the eight smallest states together is Texas?
6. Find the two rectangular states, Wyoming and Colorado. Copy the numbers that tell their areas. How much larger is Colorado than Wyoming?
7. Calling the length of Wyoming 360 miles, how wide is it?
8. Calling the length of Colorado 385 miles, how wide is it?
9. Supply the missing numbers. Extend the quotients to the first decimal place only.
  - a. California is . . . times as large as New York.
  - b. California is . . . times as large as Illinois.
  - c. California is . . . times as large as Massachusetts.

## 34. Drawing to Scale

*In Ex. 1, 2, and 3, let  $\frac{1}{8}$  in. stand for a foot.*

1. Draw a rectangular garden 20 ft. by 50 ft.
2. Draw a rectangular garden 25 ft. by 30 ft.
3. Draw a baseball diamond 90 ft. on each side.

*In Ex. 4, 5, and 6, let  $\frac{1}{2}$  in. stand for 1 mile.*

4. Draw a road running 7.25 miles north, then 5.5 miles east, then 6.75 miles south.
5. Draw a road running  $3\frac{1}{2}$  mi. north, then  $2\frac{3}{4}$  mi. east, then  $4\frac{1}{4}$  mi. south.
6. Draw a township 6 mi. square.

*In Ex. 7, 8, 9, and 11, let a space  $\frac{1}{4}$  in. long and  $\frac{1}{4}$  in. wide represent 1 acre.*

7. Draw a square farm containing 9 acres.
8. Draw a square farm containing 16 acres.
9. Draw a square farm containing 25 acres.
10. (a) Using the scale used in Ex. 7, 8, and 9, draw a 10-acre farm that is  $2\frac{1}{2}$  times as long as it is wide.  
(b) Draw a 16-acre farm that is four times as long as it is wide.
11. Using the scale used in Ex. 7, 8, and 9, draw a 40-acre farm that is 80 rods long. (*1 Acre = 160 sq. rd.*)
12. Drawing with a scale of 20 ft. to an inch (a) What will a line  $\frac{3}{4}$  in. long represent? (b) What will a line  $1\frac{1}{4}$  in. long represent?
13. What will a line  $1\frac{3}{8}$  in. long represent: (a) When the scale is 100 miles to an inch? (b) When the scale is 50 mi. to an inch? (c) When the scale is 400 mi. to an inch?
14. Draw a plan of the ground floor of a house such as you would like to have, to the scale of  $\frac{1}{4}$  in. to a foot. Then write the real length and width of each room.



1. Write the results. Do not copy the numbers. Do the work mentally ("mentally" means "in your mind").

A.  $15 + 25 =$      $100 - 79 =$      $7 \times \$.25 =$      $\frac{1}{6}$  of \$ 2.10 =  
 $35 + 45 =$      $100 - 44 =$      $9 \times .25 =$      $\frac{1}{8}$  of \$ 2.00 =  
 $28 + 15 =$      $100 - 23 =$      $6 \times .25 =$      $\frac{1}{5}$  of \$ 3.00 =  
 $36 + 22 =$      $100 - 58 =$      $5 \times .36 =$      $\frac{1}{4}$  of \$ 3.00 =  
 $45 + 17 =$      $100 - 36 =$      $3 \times .36 =$      $\frac{1}{3}$  of \$10.50 =

B.  $49 + 19 =$      $100 - 87 =$      $4 \times .49 =$      $\frac{1}{12}$  of \$ 6.00 =  
 $24 + 18 =$      $100 - 15 =$      $9 \times .49 =$      $\frac{1}{3}$  of \$ 7.50 =  
 $57 + 26 =$      $100 - 32 =$      $6 \times .49 =$      $\frac{1}{4}$  of 144 =  
 $74 + 17 =$      $100 - 61 =$      $2 \times .75 =$      $\frac{1}{8}$  of 100 =  
 $43 + 39 =$      $75 - 56 =$      $5 \times .75 =$      $\frac{1}{6}$  of 150 =

C.  $75 + 18 =$      $75 - 47 =$      $9 \times .75 =$      $\frac{1}{12}$  of 132 =  
 $36 + 44 =$      $75 - 23 =$      $3 \times 1.25 =$      $\frac{1}{5}$  of 230 =  
 $49 + 27 =$      $75 - 42 =$      $6 \times 1.25 =$      $23 + 28 =$   
 $58 + 25 =$      $75 - 35 =$      $7 \times 1.50 =$      $16 + 75 =$   
 $22 + 49 =$      $75 - 53 =$      $4 \times 1.50 =$      $48 - 19 =$

D.  $36 + 18 =$      $75 - 68 =$      $2 \times .98 =$      $48 - 22 =$   
 $44 + 29 =$      $50 - 17 =$      $6 \times .98 =$      $18 \times .40 =$   
 $28 + 36 =$      $50 - 32 =$      $8 \times .98 =$      $24 \times .60 =$   
 $53 + 17 =$      $50 - 43 =$      $3 \times 3.10 =$      $26 + 17 =$   
 $37 + 28 =$      $50 - 29 =$      $4 \times 2.40 =$      $48 - 37 =$

E.  $45 + 19 =$      $50 - 24 =$      $5 \times .99 =$      $15 \times .50 =$   
 $49 + 48 =$      $36 - 18 =$      $7 \times .79 =$      $2 \times 2.25 =$   
 $35 + 26 =$      $36 - 26 =$      $3 \times 1.75 =$      $36 - 15 =$

2. What is a quick way to add 49 and 19?
3. What is a quick way to subtract 79 from 100?
4. What is a quick way to multiply 99 by 4?



(Without pencil.)

With many problems you will know at once what to do with the numbers as soon as you are told what the problem is. For example, if you were selling berries at 2 qt. for 25¢ and a man bought 6 qt. and gave you \$1, you would know at once that you had to think, " $3 \times 25¢$ , how much more to make \$1," or think, "Subtract from \$1.00 the product of  $3 \times 25¢$ ." Here are some problems that you ought to know how to solve at once. Tell how you would solve each.

1. The cost of 1 article is \$9.75. How much is the cost for 3 articles?
2. Cloth A is  $1\frac{1}{2}$  yd. wide. Cloth B is 50 in. wide. Which is wider? How much wider?
3. How many square feet are there in a rectangle  $21\frac{3}{4}$  by  $9\frac{1}{2}$  ft.?
4. Give five illustrations of different sorts of problems that you know how to solve at once.

With some problems you will have to stop and think just what it is that you are to find out, and just how you are to find it out. For example, suppose that you are selling berries at 18¢ per box and one man says, "I will give you \$3 for the whole 19 boxes," and another man says, "I will take the lot at the rate of 3 boxes for 50¢." You would have to think a little before you could tell which was the better offer, and whether either offer was near enough to your price to make it worth your while to sell.

5. Which offer would you take, if you took either?
6. Which is the better salary— $16\frac{2}{3}¢$  per hour or \$9 a week?  
You are to work 9 hours a day on M., Tu., W., Th., and Fr., and 4 hours on Sat.

When you do not at once see how to solve a problem, it is useful to think:

Question: What question is asked? What am I to find out?

Facts: What facts are given? From what am I to find it?

Use: How shall I use these facts? What shall I do with the numbers and with what I know about them?

Often it is well to write out clearly what you are going to do in a statement or equation.

1. Read this problem carefully:

There are 231 cu. in. in a gallon. How many gallons of water must be sprinkled on a lawn 16' by 25' to wet it as much as a shower that gives .34 cu. in. of water for each sq. in. of the lawn?

2. Examine what Alice, Lucy, and George wrote to help them solve it:

Question: Gallons of water falling on this lawn in a shower of .34 cu. in. per sq. in.

Facts: 1 gal. = 231 cu. in. Lawn is 16 ft.  $\times$  25 ft.

Use: Alice wrote:  $16 \times 25$  gives area in sq. ft.  
 Area in sq. ft.  $\times$  144 gives area in sq. in.  
 Area in sq. in.  $\times$  .34 gives cu. in. of water from shower. Cu. in. of water from shower divided by 231 gives gallons of water falling on the lawn in a shower of .34 in.

Lucy wrote:  $16 \times 25$ . Result of  $(16 \times 25) \times 144$ . Multiply this result by .34. Divide the last result by 231.

George wrote:

$$\text{Ans.} = \frac{(16 \times 25) \times 144 \times .34}{231}$$

## 3. Examine this problem:

How much more will  $1\frac{1}{8}$  yd. of Grade A velvet at \$1.75 per yard cost than  $1\frac{1}{4}$  yd. of Grade B velvet at \$1.50 per yard?

Write briefly notes to help you solve it on:

- (a) *The question.*                      (b) *The facts.*                      (c) *How to use them.*

Then find the answer.

## 4. Read this problem carefully. Then write brief notes to help you solve it. Then find the answer.

My mother plans to buy picture molding to go around a rectangular room 9 ft. 9 in. wide and 14 ft. 4 in. long.

How much will it cost at 8¢ per foot?

## 5. Think how to solve each of these problems. Then solve it. You may write notes about what the question is, what the facts are, and how to use the facts, if it helps you to do so.

a. How many miles of road, counting \$2200 per mile, can be built for the price of two battleships costing \$10,000,000 each?

b. What is the cost per mile for gasoline at 22¢ per gallon for an automobile that goes 56.5 miles on 5 gallons of gasoline?

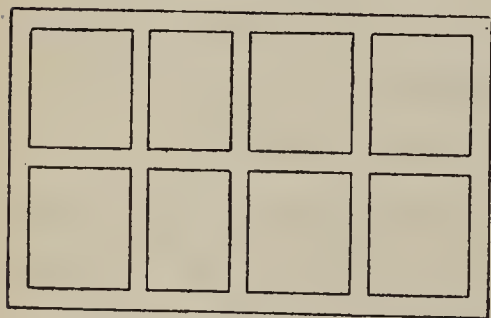

c. A garden 50 ft. long and 30 ft. wide is to be divided into 8 flower beds with a path 2 ft. wide around each bed as shown in the drawing. How long and how wide is each bed to be?

d. How much money will Joe earn in three years if he earns an average of \$3.20 per month the first year,  $1\frac{1}{2}$  times as much the second year as the first, and \$25 more the third year than the second year?



Solve these problems. Think how you are going to use the numbers before you do use them to find the answer. Write only what you need to write. Do all that you can mentally.

1. A girl buys 3 articles at 75¢ each and pays \$5. What change should she receive?
2. Mr. A. buys 6 articles at one time for 14¢ each. Mr. B. buys half a dozen at once for 75¢. How much less does Mr. B. pay than Mr. A.?
3. A girl sells an article that cost her \$7.50 for  $\frac{1}{3}$  less than cost. What does she receive for it?
4. At 6 for 25¢, what is the cost of 3 dozen?
5. At 10¢ per yard, what is the cost of a piece  $10\frac{1}{2}$  ft. long?
6. How many 30-minute periods make 3 hours, allowing 30 minutes for opening exercises and recess?
7. A boy buys a dozen rockets for 40¢ per dozen, and then sells 8 at 5¢ each and 4 at 4¢ each. How much does the boy gain?
8. How many 8-inch badges can be made from  $1\frac{1}{3}$  yd. ribbon?
9. To make a dozen belts, each  $\frac{3}{4}$  yd. long, how many yards of ribbon are needed?
10. A train leaves Boston at 9:42 A.M. It should arrive at Lowell at 10:30 A.M. but arrives a quarter of an hour late. How long did it take to go from Boston to Lowell?
11. Traveling for five hours at 18 miles per hour, you go a distance of . . . . . miles.
12. Traveling for  $2\frac{1}{2}$  hours at 30 miles per hour, you go a distance of . . . . . miles.
13. Traveling 120 miles in 6 hours, you go at the rate of . . . . . miles per hour.



14. Traveling 105 miles at the rate of 15 miles per hour, you go for . . . . . hours.
15. A man bought three drums for \$1.40, \$1.35, and \$1.00. The average cost was . . . . .
16. A lady bought four neckties at an average cost of  $37\frac{1}{2}\text{¢}$ . The total cost was . . . . .
17. What is the cost of three framed pictures if each picture costs  $75\text{¢}$  and each frame  $40\text{¢}$ ?
18. What is the total area covered by a house  $32\text{ ft.} \times 20\text{ ft.}$  with a porch  $30\text{ ft.} \times 10\text{ ft.}$ ?
19. How many garden plots each containing 50 sq. ft. can be made from a lot  $40\text{ ft.} \times 100\text{ ft.}$ , leaving 500 sq. ft. for paths?
20. Find the total cost of three chairs, at \$5.25 each, and a sofa for \$20.
21. At  $40\text{¢}$  per lb. for candy and  $5\text{¢}$  each for fancy boxes, what is the cost of 6 fancy boxes, each containing  $\frac{1}{2}$  lb. of candy?
22. What is the cost per dress when it requires \$3.50 for material and \$4.50 for labor for a dozen dresses?
23. From a piece of cloth 10 yd. long two pieces are cut, one  $2\frac{1}{2}$  yd., the other  $2\frac{1}{4}$  yd. How many yards are left?
24. A piece of cloth 6 in. wide is used to make a ruffle.  $1\frac{1}{2}$  in. is turned under on one side and  $\frac{3}{4}$  in. on the other. How wide is the finished ruffle?
25. Counting  $\frac{5}{8}$  yd. to make one apron, how much is needed to make two dozen aprons?
26. Which costs less, a rug  $9\text{ ft.} \times 12\text{ ft.}$  at \$21.50 or the same amount of carpet at \$2.00 per sq. yd.?
27. How much longer are seven periods of 55 minutes each than eight periods of three quarters of an hour each?

Find how long Mary was allowed to play on each of these days:

1. *Monday*. It is 4:10 P.M. Mother says to Mary, "You may play till quarter past five."
2. *Tuesday*. It is 4:20 P.M. Supper is at 6 o'clock. Mother says, "You may play half the time from now till supper time."
3. *Wednesday*. It is 4:05 P.M. Mother says, "If you will help me for half an hour now and for 10 minutes before supper, you may play the rest of the afternoon."
4. *Thursday*. Mother says, "You may play 20 minutes and  $2\frac{1}{2}$  minutes more for every dish you wash." Mary washes 28 dishes.
5. *Friday*. Mother says, "You may play 2 minutes for every 3 problems you solve, and 5 minutes more for every problem you solve correctly." Mary solves 15 and has all but one right.
6. *Saturday*. Mother says, "You may play 2 hours for nothing. Also I will allow you 10 minutes for every problem you solve correctly, but will take off 10 minutes for every problem that is wrong. Also you may play  $1\frac{1}{2}$  minutes for every minute you help me by minding your little brother." Mary did 10 problems, and had only one of them wrong. She minded the baby for an hour and a quarter.

Supply the missing numbers:

7. Half of the sum of 6 and 12 = ...
8. Two thirds of the product of 9 and 7 = ...
9.  $\frac{5}{8}$  of the difference between  $9\frac{3}{4}$  and  $12\frac{1}{2}$  = ...
10.  $6 \times 2\frac{1}{2}\text{¢} = \dots$  of  $\frac{3}{5}$  of a dollar.
11. What part of 10 equals  $\frac{5}{6}$  of 3?

Here is a problem ladder. Begin at the bottom and climb to the top. All the problems ask the same question, "How many minutes is it from the time John begins to pump until the tank is filled?" The tank holds 120 gallons and is supposed always to be empty when John begins to work.

6. John pumps for 1 min. 50 sec. before any water reaches the tank. Then he pumps at the rate of 3.6 gallons per minute for 10 min., then rests 5 min., then pumps 3.6 gal. per minute for 10 min., then rests 5 min., then pumps 3.6 gal. per minute for 10 min., then rests 5 min., and so on until the tank is filled.
5. John pumps  $1\frac{3}{4}$  min. before any water reaches the tank. Then he pumps for 10 min. at the rate of 2.7 gallons per minute. Then the pump breaks and he spends 8 min. mending it. Then he pumps at the rate of 3.1 gallons per minute until the tank is full.
4. John pumps 2 min. before any water reaches the tank. Then he pumps for 15 min. at the rate of 3 gallons per minute. Then Dick helps him and they pump at the rate of 5 gallons per minute until the tank is full.
3. John pumps 1 min. before any water reaches the tank. Then he pumps water into it at the rate of 24 gallons in 10 minutes until the tank is full.
2. John pumps  $1\frac{1}{2}$  min. before any water reaches the tank. Then he pumps water into it at the rate of 3 gallons a minute, for 20 min. Then he pumps at the rate of 2 gallons a minute until it is full.
1. John pumps 2 minutes before any water reaches the tank. Then he pumps water into it at the rate of 3 gallons a minute until the tank is full.

\* TO THE TEACHER.—Make sure that the question and the general conditions of this set of problems are understood before even Ex. 1 and 2 are attempted.



1. Do you keep any written accounts of what money you earn and have given to you? If you do, show on the blackboard how you keep your accounts. If you don't, show on a sheet of paper how you would keep Fred's accounts, for the first two weeks of December. Fred had \$2.48 Mon., Dec. 1. On Dec. 3 he earned 45¢ by shoveling snow, and spent 25¢ for an electric battery. On Dec. 8 Fred had \$2.68. He earned 15¢ Dec. 10 by going on an errand. On Dec. 11 he earned 35¢ by shoveling snow. On Dec. 12 he earned 20¢ by helping on a grocer's wagon, and spent 10¢ for two tickets to the moving pictures. On Dec. 13 he spent 25¢ for a Christmas present for his mother, 15¢ for a present for his father, 25¢ each for presents for his brother and sister, and 10¢ each for presents for his friends, Dick and Charles.
2. Examine the plans that other children have made for keeping accounts.
  - (a) Why is it useful to enter what you receive (receipts) and what you pay on opposite pages or on the right and left halves of a page, or in two separate columns?
  - (b) What do you think "balancing an account" means?
  - (c) Ask the children who balance their accounts every week, why they do so.

A plan for keeping accounts should help anybody to know seven things:

- |  |                           |
|--|---------------------------|
| I. How much was received.  | IV. How much was spent.   |
| II. What it was received for.  | V. What it was spent for. |
| III. When it was received.   | VI. When it was spent.    |
| VII. How much money the person had left over at the end of each week or month. |                           |



## 1. Examine this part of Will's accounts.

RECEIVED			PAID		
Nov. 2	Cash on hand	4 29	Nov. 2	Sunday School	02
5	Errand for Mr. D.	10	5	Meccano parts	30
6	Old skates sold	45	8	Balance	4 92
8	4 hrs. work, Mr. S.	40			
		<u>5 24</u>			<u>5 24</u>
Nov. 9	Cash on hand	4 92	Nov. 9	Sunday school	05
11	Globe prize	3 00	12	Meccano motor	1 50
14	Gift, Uncle Joe	1 00	14	Skates	1 35
15	4 hrs. work, Mr. S.	40	14	Moving pictures (4)	40
		<u>9 32</u>	15	Balance	6 02
					<u>9 32</u>
Nov. 16	Cash on hand	6 02			

- Compare the *Balance* item of Nov. 8 with the *Cash on hand* item of Nov. 9. Compare the *Balance* item of Nov. 15 with the *Cash on hand* item of Nov. 16. Many people do not enter the balances at all. They are not necessary in this sort of account, but are useful.
- How did Will find that \$4.92 was right for the *Balance* item of Nov. 8 and the *Cash on hand* item of Nov. 9?
- These accounts are balanced and closed Nov. 8 and opened again on Nov. 9. They are balanced and closed again Nov. 15 and opened again on Nov. 16. A red-ink line or double line is useful to show clearly that the account is balanced and closed ready for next week's new account to begin. What item is always entered first on the RECEIVED side when the account is opened?
- What would you enter as the amount of *Cash on hand* if you had spent all your money?
- (a) Is it right to think of the *Balance* as paid by Will at the end of one week to Will at the beginning of the

next week? (b) Why do many people write *Paid to new account* instead of *Balance*?

7. Which of these phrases do you think might be used instead of *Cash on hand*? Which might be used instead of *Balance*? Which might be used instead of *Received*? Which might be used instead of *Paid*?  
*Amount brought forward. Expenditures. To new account. Brought forward. Receipts. Income. On hand.*
8. Many people write at the side of the PAID account each week the total amount *paid that week*. If Will did this, what would he write for the week of Nov. 2 to 8? For the week of Nov. 9 to 15?
9. What do you think of the plan of writing at the side of the RECEIVED account each week the total amount received that week, except the cash on hand from previous weeks?
10. If Will used the plan of Ex. 9, what would he write or enter as the actual new receipts for the week of Nov. 2 to 8? For the week of Nov. 9 to 15?
11. What was Will's average income or new receipts per week for the two weeks?
12. What was Will's average outgo or actual payments, not counting the *Balance* item, per week for the two weeks?
13. Play that on Saturday night, Jan. 4, you had \$2.34 in cash and that you earned and spent the following:  
Sun, Jan. 5.—Pd. Sunday School, 2¢. Pd. Club 5¢.  
Th., Jan. 9.—Rec'd 10¢ for errand. Pd. book, 15¢.  
Sat. Jan. 11.—Rec'd for 3 hours work, 25¢. Gift, \$1.00.  
Make up your accounts for the week.
14. In how much less time can you save \$3.00 if you save 15¢ a week than if you save 12¢ a week?

## 43. Practice in Keeping Accounts

1. Play that you have an allowance of \$2.75 to start with, and an allowance of 50¢ per week, and are given 10 or 20 cents to spend two or three times a week by your father. Choose what you will buy each week for three weeks and write your accounts for the three weeks.
2. Play that you are through school and are earning your own living, making \$8 a week in a store or a factory, and extra money sometimes by evening work. You have \$15.25 to begin with, you pay \$4.50 a week for board, lodging, and laundry. Think what else you would need to buy. Write out your accounts for three weeks.
3. On the last day of Dec. each year, Will makes a classified arrangement of his accounts for that year like the one shown on page 173. He fills the blanks in these lines with the correct numbers. Fill them as he does. If you are a girl, you can make out a page to fit a girl, and use it instead, if you prefer.

RECEIPTS		EXPENDITURES	
<i>a. Gifts</i>	...	<i>Tools</i>	...
<i>b. Prizes</i>	...	<i>Meccano</i>	...
<i>c. Sales</i>	...	<i>Sporting goods</i>	...
<i>d. Regular work</i>	...	<i>Clothes</i>	...
<i>e. Odd jobs</i>	...	<i>Entertainments</i>	...
		<i>Presents</i>	...
		<i>Candy, etc.</i>	...
		<i>Sunday school, etc.</i>	...
		<i>Miscellaneous</i>	...
<i>Total earnings (d + e)</i>	...	<i>Grand total</i>	...
<i>Grand total</i>	...	<i>Balance to put in bank</i>	...
<i>Average earnings per week</i>	...	<i>Average spent per week</i>	...

## WILL'S CLASSIFIED ARRANGEMENT OF ACCOUNTS FOR THE YEAR

RECEIPTS		EXPENDITURES		
Gifts	Odd Jobs	Tools	Special clothes not paid for by parents	Presents, Christmas, birth- days, etc.
.25	.25	.65		.25
.50	.15	.35		.25
5.00	.05	.28	.25	.50
.75	.10	1.45	.25	.30
1.00	.25	2.80	4.50	.50
.25	.30			.30
	.15			.50
Prizes	.20	Meccano	Entertainments	.10
3.00	.25	.15	.10	.10
	.05	6.00	.05	.75
Sales of second- hand toys	.10	.20	.25	.50
.65	.10	.40	.10	
.30	.40	.30	.10	
.45	.25	1.50	.35	Candy, sodas, etc. (in all)
	.20		.10	8.65
	.15	Sporting goods	.10	
Delivering papers, 23 wk. at 1.10 per wk.	.35	2.25	.25	Sunday school, hospital, etc. (in all)
	.20	.50	.10	1.72
	.15	1.00	.10	
For Mr. S. 17 wk. at .40 per wk., 11 wk. at 1.00 per wk.	.25	.75	.10	
	.25	.89	.10	
	.10	1.25	.20	
	.25		.10	
Balance from last year	.50		.35	Miscellaneous 4.35
.00	.75			
	.10			
	.15			
(Will put all that he had left last year in the Savings Bank)	1.00			



Mrs. Lewis has bought some dry goods from R. Stern & Co. They send her this bill.

Chicago, Ill., Aug. 4, 1915

Mrs. C. H. Lewis,

Evanston, Ill.

Bought of R. STERN & Co.

Michigan Ave.

July 14	2 $\frac{1}{4}$ yd. Ribbon	19		43		
	2 Ties	25		50		
	4 Collars	2 for 25		50		
	1 Suit		2	85		
" 27	3 Suits	1.55	4	65		
	2 pkg. Envelopes	05		10		
	7 $\frac{1}{2}$ yd. Muslin	12		90		
	8 Hdkfs.	25	2	00		
	1 pr. Shoes		3	50		
	1 Dress		1	50		
						16 93

This bill has a place for the date of each purchase, a place for the description of the goods, a place for the price of the goods, a place for the cost of each item, and a place for the total amount of all the purchases. The amount of each item is called an *extension*. The total of all the extensions is called the *footing*. 43, 50, 50, and 2.85 are *extensions*.

1. What are the other extensions on this bill?
2. How much is the footing of this bill?
3. Bring to school to-morrow some bill or statement or sales slip that you can get from your parents. Examine it to see what the numbers mean so that you can put a copy on the blackboard and tell the other children about it.

All prices are printed in cents. 1 25 means \$1.25. 03 means 3 cents.

(Use pencil only when you need to. Do as much as you can mentally.)

State the cost of —

- |   |                 |
|---|-----------------|
| 1. 2 pr. sandals  | at 1 25         |
| 2. 2½ yd. ribbon  | 17              |
| 3. 3 soaps  | 18              |
| 4. 8¾ yd. gingham   | 16              |
| 5. ⅞ yd. velvet   | 2 00            |
| 6. 4 bolts  | 03              |
| 7. 3½ yd. copper screen   | 42              |
| 8. 10 lb. nails   | 06½             |
| 9. 1 hammer   | 65              |
| 10. 2 gal. oil  | 70              |
| 11. ½ lb. E. B. tea   | 80              |
| 12. 4 3½-oz. tins smoked beef   | 14              |
| 13. 3 cans D. M. green asp. tips  | 19              |
| 14. 2 cans Golden wax beans   | 15              |
| 15. 4½ lb. butter   | 34              |
| 16. 3⅜ lb. bacon  | 24              |
| 17. 1 bag Gold Medal flour  | 90              |
| 18. 3 large jars grape jelly  | 27              |
| 19. 1½ lb. lard   | 18              |
| 20. 6 cans ungraded Dainty peas   | 1 40 (per doz.) |
| 21. Make out a bill, supposing that you sold the first five items to Mrs. A. C. Webb, 7 Ross Ave.                                       |                 |
| 22. Make out a bill such as your father would receive if he bought items 6, 7, 8, 9, and 10. Name some merchant near you as the seller. |                 |
| 23. Make a bill for items 11 to 20, naming yourself as buyer and some merchant near you as the seller.                                  |                 |

You may save time by omitting the \$ and ¢ signs.

Every day with each order of groceries Dow & Co. send a slip like this:

Dalton, Ohio 10/17 1915

M R. A. Adams

### W. F. DOW & CO.

Choice Groceries and Meats

Tel. 57-W

		Account Forwarded	13	03
Oct. 17	5 $\frac{1}{2}$ rib roast		1	21
	5 corn meal			15
	6 bananas			10
	$\frac{1}{2}$ fig newtons			9

This slip tells Mrs. Adams what articles she has been charged with that day, and how much she has spent since her last payment to Dow & Co. up till that day.

1. What does the 13.03 tell?
2. What does the 10/17 at the top of the bill tell?
3. What number will probably be written as "Account forwarded" in the next slip that Mrs. Adams receives?
4. How much was the rib roast per lb.?
5. How much was the corn meal per lb.?
6. How much were the bananas per doz.?
7. How much were the fig newtons per lb.?
8. Mrs. Adams plans to spend not over \$600 a year for meat and groceries. How much does that allow her per week?

Many storekeepers do not use a whole line for each item of their sales slips, but write like this, putting the sum for each line in the *extensions* column, as shown here for the first two lines:

Feb. 2	2 coffee 56, $\frac{1}{2}$ tea 30, 1 mac. 09.....	95
	5 hominy 22, 2 smoked beef 28.....	50
Feb. 5	3 corn 27, 6 peas 70, 2 oz. vanilla 25.....	
	4 grapefruit 25, 2 bot. pickles 30.....	
Feb. 9	6 bananas 13, $\frac{3}{4}$ Swiss cheese 34.....	
	2 doz. eggs 84, 1 gelatine 18.....	
Feb. 12	4 butter 1.28, 1 flour 90.....	
	$\frac{1}{4}$ bak. powder 10, 2 jars bacon 60.....	

1. Tell what the sum is: (a) For line 3. (b) For line 4.

(Do not use pencil. Do the adding in your head.)

2. Tell the sums for lines 5, 6, 7, and 8.
3. If you kept a store and made out sales slips would you write both prices and extensions, or only extensions? Why?
4. Would you put more than one item on a line? Why?
5. If you bought goods, would you rather have a sales slip with both prices and extensions, or a slip with only extensions? Why?
6. Practice adding numbers written on a line like those in the sales slip. Use these numbers. Add them mentally ("mentally" means "in your mind") and write the sums:

a. 37	20	25	e. 16	10	25	i. 19	67	20
b. 10	28	40	f. 05	60	17	j. 30	14	72
c. 25	35	12	g. 30	18	22	k. 10	45	48
d. 9	32	15	h. 12	14	19	l. 1.05	16	75



1. Tell the missing numbers.

(Use pencil if you cannot find the correct result mentally.)

A.	B.	C.	D.
$2 \times 12 =$	$\frac{1}{8}$ of \$1 = ... ¢	$\frac{1}{2} + \frac{1}{4} =$	$4 = \dots$ dozen
$3 \times 12 =$	$\frac{1}{6}$ of \$1 = ... ¢	$\frac{1}{2} + \frac{3}{4} =$	$3 = \dots$ dozen
$4 \times 12 =$	$\frac{1}{5}$ of \$1 = ... ¢	$\frac{1}{2} + \frac{1}{8} =$	$2 \text{ oz.} = \dots$ lb.
$5 \times 12 =$	$\frac{1}{4}$ of \$1 = ... ¢	$\frac{1}{2} + \frac{3}{8} =$	$3 \text{ oz.} = \dots$ lb.
$6 \text{ dozen} =$	$\frac{1}{3}$ of \$1 = ... ¢	$\frac{1}{2} + \frac{5}{8} =$	$4 \text{ oz.} = \dots$ lb.
$7 \text{ dozen} =$	$\frac{3}{8}$ of \$1 = ... ¢	$\frac{1}{2} + \frac{7}{8} =$	$5 \text{ oz.} = \dots$ lb.
$8 \text{ dozen} =$	$\frac{5}{8}$ of \$1 = ... ¢	$\frac{1}{4} + \frac{1}{8} =$	$6 \text{ oz.} = \dots$ lb.
$9 \text{ dozen} =$	$\frac{2}{3}$ of \$1 = ... ¢	$\frac{1}{4} + \frac{3}{8} =$	$7 \text{ oz.} = \dots$ lb.
$10 \text{ dozen} =$	$\frac{3}{4}$ of \$1 = ... ¢	$\frac{1}{4} + \frac{5}{8} =$	$8 \text{ oz.} = \dots$ lb.
$12 \text{ dozen or}$	$\frac{7}{8}$ of \$1 = ... ¢	$\frac{1}{4} + \frac{7}{8} =$	$9 \text{ oz.} = \dots$ lb.
$1 \text{ gross} =$	$\frac{3}{4}$ of 25 =	$\frac{3}{4} + \frac{1}{4} =$	$10 \text{ oz.} = \dots$ lb.
$5 \times 25 =$	$\frac{3}{4}$ of 30 =	$\frac{3}{4} + \frac{1}{2} =$	$11 \text{ oz.} = \dots$ lb.
$6 \times 25 =$	$\frac{1}{4}$ of 10 =	$\frac{3}{4} + \frac{1}{8} =$	$12 \text{ oz.} = \dots$ lb.
$7 \times 25 =$	$\frac{1}{4}$ of 18 =	$\frac{3}{4} + \frac{3}{8} =$	$13 \text{ oz.} = \dots$ lb.
$8 \times 25 =$	$\frac{1}{4}$ of 22 =	$\frac{3}{4} + \frac{5}{8} =$	$14 \text{ oz.} = \dots$ lb.

2. Repeat A, B, C, and D until you can do all four columns correctly in less than three minutes.

3. Tell the missing numbers for E, F, G, and H.

E.	F.	G.	H.
$6 \times 25 =$	$\frac{3}{4} + \frac{3}{8} =$	$5 \times \frac{1}{2} =$	$9 \times 25¢ =$
$6 \times \frac{1}{4} =$	$\frac{7}{8} + \frac{1}{2} =$	$5 \times \frac{1}{4} =$	$9 \text{ dozen} =$
$6 \times 1\frac{1}{2} =$	$\frac{7}{8} + \frac{1}{4} =$	$5 \times 25¢$	$\frac{1}{4}$ of 18 =
$\frac{1}{4}$ of 22 =	$8 \times 25 =$	$\frac{1}{4}$ of 18 =	$\frac{1}{4}$ of 26 =
$\frac{1}{4}$ of 25 =	$8 \times \frac{1}{4} =$	$\frac{1}{4}$ of 26 =	$4 \text{ oz.} = \dots$ lb.
$\frac{1}{4}$ of 30 =	$8 \times \frac{3}{4} =$	$\frac{1}{4}$ of 30 =	$10 \text{ oz.} = \dots$ lb.
$\frac{3}{8}$ of \$1 = ... ¢	$8 \times 1\frac{1}{2} =$	$\frac{1}{4} + \frac{1}{2} =$	$\frac{1}{8}$ of \$1 = ... ¢
$\frac{7}{8}$ of \$1 = ... ¢	$8 \times 12\frac{1}{2}¢ =$	$\frac{1}{4} + \frac{5}{8} =$	$\frac{1}{3}$ of \$1 = ... ¢

4. Repeat E, F, G, and H until you can do all four columns correctly in less than 2 minutes.

1. State the missing products. Express all results in lowest terms. Then express them to the nearest cent, counting  $\frac{1}{2}$  cent as 1¢.

(Do not use pencil and paper, if you can find the correct result mentally.)

A.	C.	E.	G.
$\frac{1}{2} \times 17 =$	$\frac{3}{4} \times 25 =$	$\frac{1}{4} \times 25 =$	$\frac{1}{8} \times 30 =$
$\frac{1}{8} \times 22 =$	$\frac{3}{8} \times 22 =$	$\frac{7}{8} \times 28 =$	$\frac{3}{8} \times 38 =$
$\frac{3}{8} \times 18 =$	$\frac{1}{4} \times 23 =$	$\frac{5}{8} \times 44 =$	$\frac{7}{8} \times 42 =$
$\frac{3}{8} \times 42 =$	$\frac{5}{8} \times 38 =$	$\frac{3}{4} \times 36 =$	$\frac{1}{4} \times 29 =$
$\frac{1}{2}$ of 45 =	$\frac{1}{2}$ of 35 =	$\frac{1}{2}$ of 75 =	$5 \times 28 =$
$\frac{1}{4} \times 22 =$	$3 \times 28 =$	$4 \times 22 =$	$\frac{7}{8} \times 18 =$
$4 \times 28 =$	$\frac{3}{4} \times 14 =$	$\frac{1}{4} \times 28 =$	$\frac{1}{2}$ of 4 =
$3 \times 23 =$	$3 \times 15 =$	$\frac{1}{2}$ of 15 =	$\frac{1}{2}$ of 19 =
$5 \times 16 =$	$\frac{5}{8} \times 18 =$	$\frac{3}{4}$ of 15 =	$\frac{5}{8}$ of 20 =
$\frac{3}{4} \times 19 =$	$6 \times 1\frac{1}{4} =$	$\frac{3}{8}$ of 44 =	$4 \times 16 =$
$5 \times 1\frac{1}{2} =$	$\frac{1}{4} \times 24 =$	$3 \times 16 =$	$9 \times 16 =$
$\frac{3}{8} \times 28 =$	$\frac{5}{8} \times 28 =$	$3 \times 1\frac{1}{4} =$	$\frac{3}{4} \times 17 =$
B.	D.	F.	H.
$8 \times 1\frac{1}{4} =$	$6 \times 16 =$	$\frac{1}{4} \times 32 =$	$4 \times 1\frac{1}{4} =$
$\frac{1}{4} \times 26 =$	$\frac{1}{2}$ of 25 =	$7 \times 1\frac{1}{4} =$	$2 \times 1\frac{3}{4} =$
$2 \times \$1.25 =$	$\frac{1}{8}$ of 20 =	$\frac{5}{8} \times 22 =$	$5 \times \$1.25 =$
$\frac{1}{2}$ of 21 =	$\frac{7}{8}$ of 44 =	$\frac{1}{4} \times 34 =$	$\frac{3}{4} \times 22 =$
$3 \times \$1.50 =$	$7 \times 16 =$	$\frac{7}{8} \times 30 =$	$\frac{3}{8} \times 30 =$
$\frac{3}{4} \times 38 =$	$\frac{1}{4} \times 27 =$	$3 \times 1\frac{3}{4} =$	$6 \times 15 =$
$8 \times 16 =$	$4 \times 15 =$	$\frac{3}{4} \times 22 =$	$4 \times 9 \text{ oz.} =$
$\frac{1}{4} \times 30 =$	$3 \times 12\frac{1}{2} =$	$5 \times 15 =$	$\frac{3}{4} \times 26 =$
$6 \times \$1.50 =$	$\frac{3}{4} \times 18 =$	$4 \times 1\frac{3}{4} =$	$6 \times 23 =$
$\frac{3}{8}$ of 20 =	$12 \times 12 =$	$4 \times 12 =$	$5 \times 12\frac{1}{2} =$
$7 \times 12 =$	$4 \times 23 =$	$\frac{3}{4} \times 24 =$	$8 \times 12 =$
$\frac{1}{4} \times 35 =$	$\frac{1}{4} \times 31 =$	$5 \times 23 =$	$\frac{1}{6} \times 100 =$

2. Repeat A, B, C, D, E, F, G, and H of Ex. 1 until you can say all the products without a mistake in 8 minutes.

## 50. Practice in Adding Long Columns

In keeping your own accounts and in adding up household bills, it will save you time and money if you can add a long column of figures without ever making a mistake. Practice with these. Do not copy the numbers. Take a slip of paper. First add upward, and write the sums on the slip of paper. Then check your result by adding downward, writing the sums on another slip of paper. Keep the two slips. To-morrow find the sums again with a new slip of paper. Did you have all right each time?

*All the numbers mean amounts of money. Decimal points are omitted. 25 means \$.25. 108 means \$1.08.*

1.	2.	3.	4.	5.	6.	7.	8.
25	18	123	15	56	15	11	10
10	32	10	24	127	52	08	106
108	25	35	118	45	139	66	87
73	74	93	84	113	25	115	72
05	121	154	19	25	30	10	133
25	56	25	25	08	19	74	26
12	05	25	10	64	05	25	25
126	42	18	146	145	16	15	58
69	130	63	87	78	116	09	30
72	15	132	25	25	19	87	19
34	93	05	78	17	08	148	52
25	24	25	117	10	68	59	108
10	10	62	59	46	127	18	49
05	25	146	05	148	34	25	07
135	129	48	37	75	25	157	36
68	35	15	136	87	10	13	112
60	124	18	63	82	28	49	92
145	20	45	95	93	80	218	144
140	64	22	169	18	92	125	60
<u>95</u>	<u>36</u>	<u>135</u>	<u>22</u>	<u>90</u>	<u>163</u>	<u>42</u>	<u>65</u>

All the numbers mean amounts of money. Decimal points are omitted. 25 means \$.25. 108 means \$1.08.

9.	10.	11.	12.	13.	14.	15.	16.
32	75	72	96	25	25	78	206
72	33	85	78	55	78	36	520
56	84	76	122	75	76	34	36
113	74	29	33	80	25	45	19
97	32	119	75	684	155	131	76
64	45	79	36	44	67	54	157
65	68	75	47	127	34	945	70
25	649	68	55	38	18	18	34
152	64	55	647	55	128	69	95
16	149	65	57	147	68	25	136
55	16	32	25	17	55	156	75
10	57	17	154	29	59	96	47
78	114	25	66	67	917	75	25
86	75	156	17	33	97	69	48
425	25	75	94	75	75	55	75
520	419	398	197	708	46	428	39
75	90	75	75	93	186	75	756
192	75	93	879	193	75	58	187
108	188	58	825	416	419	184	426
<u>709</u>	<u>55</u>	<u>195</u>	<u>45</u>	<u>98</u>	<u>37</u>	<u>508</u>	<u>55</u>

TO THE TEACHER.—These two pages can be used indefinitely throughout the year for practice in long column addition, by having one, two, or more rows covered by slips of paper or by preparing cards to lay on the page with additional numbers to be added. Do not let time be wasted in copying the numbers. Special drills on that sort of clerical work will be provided later. Do not urge speed except as a symptom of sure control of the process. Long column addition in business is now a matter of machine work. The work here is for accuracy in personal, household, and farm accounts. Allow the writing of partial sums, addition of the upper and lower ten numbers separately, and other rational checks in the case of those pupils who need them. Focus on the ability to get an absolutely accurate result.



## 51. Playing "Bank"

1. Sometimes people pay their bills with checks instead of money. A check is an order to a bank where you have money to pay a certain amount of money to a certain person. Examine the check shown here.

No. <u>297</u>	NEW YORK, <u>Feb. 10</u> 191 <u>6</u>
<b>THE CORN EXCHANGE BANK</b>	
Pay to <u>Peter Gordon</u>	or order
<u>twenty - six and <math>\frac{42}{100}</math></u>	Dollars
<u>\$ 26.42</u>	<u>William Raud</u>

2. What bank is to pay the money on this check?
3. How much money is the bank to pay?
4. To whom is the bank to pay it?
5. Establish four branches of the Sixth-Grade National Bank in the four corner desks of the room. Make 20 dollars worth of play money. Deposit it in the bank (at any branch).
6. Choose a pupil to be bookkeeper to make a list of the members of the class and write \$20 after each name when that pupil deposits \$20.
7. Make out two checks on the Sixth-Grade National Bank for any amount over \$6 and under \$10. Make them payable (in play money) to the order of the pupil who sits across the aisle from you and give them to him (or her). Date them to-day.
8. Choose four pupils to be paying tellers at the four branches of the bank.

9. Go to the nearest bank and cash one of your checks. Write your name on the back of it, give it to the teller, and tell him what sort of money you want, all in pennies, all in nickels, all in quarters, etc. If he makes a mistake in the money he gives, or is too slow, he loses his job as teller. When he pays you, he marks the check PAID in big letters.
10. After each pupil has cashed one check, let the class help the bookkeeper write how much each boy and girl has left in the bank. Plan how to do this quickly.
11. What should the paying teller do if you presented a check for \$35 made out by a girl who had only \$2.05 left of her deposit?
12. What should the bookkeeper do if a boy does not cash his check, but asks to have the money added to his deposit?
13. Find the amount each of these children (A., B., C., D., and E. stand for their names) had left in the bank at the end of this game.
  - A. deposited \$20, made out checks for \$6.71 and \$9.05, which were cashed, then deposited \$7.75 more.
  - B. deposited \$20, made out checks for \$8.97 and \$7.75, which were cashed, then deposited \$8.40 and \$9.25.
  - C. deposited \$20, made out checks for \$8.14 and \$9.50, which were cashed, then deposited \$9.05 and \$7.46.
  - D. deposited \$20, made out checks for \$7.50 and \$8.50, which were cashed, then deposited \$8.88 and \$6.66.
  - E. deposited \$20, made out checks for \$6.07 and \$6.09, which were cashed, then deposited \$8.18 and \$6.49.
14. Find out what you can about why people use checks, and other things about checks and bank accounts that interest you.

184 52. Review Problems about Buying, Selling, and Saving

The same article is sold for different prices at different times and in different places.

1. What is the price per pound for rib roast (a) When the exact cost for  $6\frac{3}{4}$  lb. is  $94\frac{1}{2}\text{¢}$ ? (b) When it is \$1.08? (c) When it is \$1.48 $\frac{1}{2}$ ?
2. What is the price per pound for butter (a) When the cost for 1 lb. 8 oz. is  $36\text{¢}$ ? (b) When it is  $57\text{¢}$ ? (c) When it is  $51\text{¢}$ ?

PRICES

	A	B	C	D
lamb	12	15	18	22
bacon	14	16	20	26
potatoes	80	75	80	1.10
sugar	$7\frac{1}{2}$	$6\frac{3}{4}$	$6\frac{1}{4}$	$5\frac{3}{4}$

3. Make out sales slips for an order of  $5\frac{3}{4}$  lb. lamb,  $1\frac{3}{8}$  lb. bacon,  $\frac{1}{2}$  bu. potatoes, and 10 lb. sugar. In the first slip, use the A prices; in the second slip use the B prices; and so on. Enter on each slip \$12.68 as the amount brought forward for previous purchases.
4. Mrs. J. E. Fox buys from J. Vose & Co.,  $3\frac{1}{2}$  yd. velvet at \$1.75 per yd.,  $6\frac{3}{4}$  yd. serge at  $28\text{¢}$  per yd., 6 pairs of socks at 3 pairs for  $50\text{¢}$ , and three dresses, one for \$1.98, one for \$1.47, and one for  $89\text{¢}$ . Make out her bill. Supply dates and places.
5. Mrs. Fox used only part of the serge and has  $3\frac{5}{8}$  yd. left. (a) How much did she use? (b) She sells the remnant for  $50\text{¢}$ . How much is that per yard?
6. Mr. Jones's regular salary is \$1400 per year. He plans to use it as follows: (a) 15 hundredths for rent and furniture; (b) 15 hundredths for insurance and savings; (c) 42 hundredths for food, coal, wood, ice, gas, and other household needs; (d) 12 hundredths for



clothing; (*e*) 8 hundredths for church, charity, doctors' bills, and reserve fund; (*f*) 8 hundredths for books, gifts, music, and vacation expenses. How much does he plan to expend per year for *a*? For *b*? For *c*? For *d*? For *e*? For *f*?

7. What should be the sum of your results for *a*, *b*, *c*, *d*, *e*, *f* in Ex. 6, if all your work is correct?
8. Mr. Roe's salary is \$1200 per year. He allows \$180 for rent and furniture; allows \$132 for insurance and savings; keeps \$120 to spend himself for clothes, etc.; and gives the rest to Mrs. Roe to use for food, clothing, doctors' bills, etc. How many hundredths of his salary does he:
  - (*a*) Allow for rent and furniture?
  - (*b*) Allow for insurance and savings?
  - (*c*) Keep to spend himself?
  - (*d*) Give to Mrs. Roe to spend for the family?
9. What should be the sum of your results for *a*, *b*, *c*, and *d* in Ex. 8, if your work is all correct?
10. Dick earned \$17.40 in the summer. He plans to spend 35 hundredths of it now for tools, to put 45 hundredths of it in the savings bank, and to keep the rest to spend later.
  - (*a*) How much does he plan to spend for tools?
  - (*b*) How much shall he put in the savings bank?
  - (*c*) How many hundredths of the \$17.40 does he keep to spend later?
11. Lucy earned \$22.50 in the summer. She spent \$4.25 for books and \$4.05 for clothes. The rest of the money she put in the savings bank.
  - (*a*) How many hundredths of the \$22.50 did she put in the bank?
  - (*b*) How many hundredths of it did she spend for books?



Store	School			Garage
Store	Store	Store	Store	

1. How many tenths of this block are covered by stores?
2. How many tenths are covered by the garage?

3. How many tenths are covered by the school?

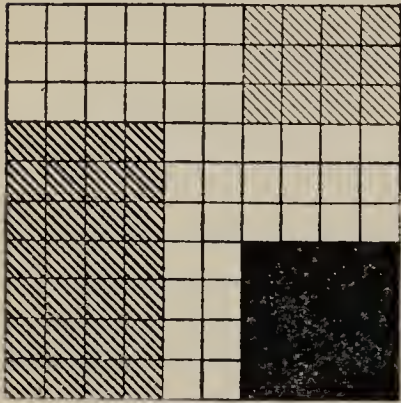

4. How many hundredths of this drawing are solid black?
5. How many hundredths of this drawing are heavily shaded?
6. How many hundredths of this drawing are lightly shaded?
7. How many hundredths of this drawing are left white?

This is a picture of a road 35 miles long.

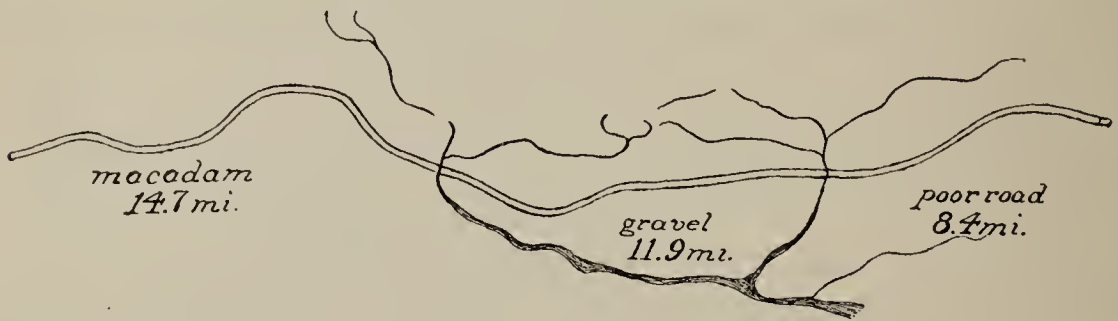

(Use pencil for 8, 9, and 10.)

8. How many hundredths of the road are macadam?  
(Use  $35 \overline{)14.70}$ )
9. How many hundredths of the road are gravel?
10. How many hundredths of the road are poor road?

**Percent means hundredths**

11. Supply the missing numbers as is done in the first line:  
 15 percent of \$200 means  $.15 \times \$200$ , or \$30.  
 5 percent of \$2000 means  $\dots \times \$2000$ , or \$100.  
 70 percent of 200 ft. means  $\dots \times 200 \text{ ft.}$ , or 140 ft.  
 8 percent of 50 mi. means  $\dots \times 50 \text{ mi.}$  or 4 mi.

I. State the products:

A.	B.	C.	D.
$.04 \times \$210$	$12 \times 60 \text{ mi.}$	$20 \times 132 \text{ ft.}$	$.60 \times 60 \text{ mi.}$
$.40 \times \$210$	$.12 \times 60 \text{ mi.}$	$.20 \times 132 \text{ ft.}$	$.30 \times 60 \text{ mi.}$
$.004 \times \$210$	$.012 \times 60 \text{ mi.}$	$.05 \times \$20$	$.70 \times 6 \text{ mi.}$
$.22 \times \$4.00$	$.06 \times \$9.00$	$.15 \times \$20$	$.09 \times \$1.00$
$.11 \times \$4.00$	$.006 \times \$900$	$.25 \times \$20$	$.11 \times \$1.00$
$.05 \times \$4.00$	$.09 \times 70 \text{ ft.}$	$.08 \times 120 \text{ mi.}$	$.07 \times \$1.00$
$.30 \times \$4.00$	$.40 \times 70 \text{ ft.}$	$.50 \times 120 \text{ mi.}$	$.80 \times \$1.00$
$.05 \times \$40$	$.09 \times 700 \text{ ft.}$	$.50 \times 12 \text{ mi.}$	$.06 \times \$1.00$
$.30 \times \$40$	$.40 \times 700 \text{ ft.}$	$.04 \times \$2.20$	$.06 \times \$30$

II. Write the products:

- |                                    |                                  |                                  |
|------------------------------------|----------------------------------|----------------------------------|
| 1. $.15 \times \$17.60$            | 4. $.85 \times 1240 \text{ ft.}$ | 7. $.06 \times \$21.25$          |
| 2. $.42 \times 18.4 \text{ miles}$ | 5. $.15 \times \$1.80$           | 8. $1.035 \times \$20.70$        |
| 3. $.22 \times \$1.75$             | 6. $.20 \times \$7.75$           | 9. $.18 \times 28.2 \text{ mi.}$ |

## 55.

I. State the quotients:

<i>a.</i> $14 \overline{)2.8}$	<i>b.</i> $15 \overline{)6}$	<i>c.</i> $200 \overline{)36}$	<i>d.</i> $110 \overline{)66}$
<i>e.</i> $\$25 \overline{)\$10.75}$	<i>f.</i> $\$1.25 \overline{)\$.50}$	<i>g.</i> $\$6.00 \overline{)\$1.380}$	<i>h.</i> $40 \overline{)8.4}$

II. Write the quotients. You need not extend any quotient beyond the third decimal place.

Divide each of these by \$2.25:

1.	2.	3.	4.	5.	6.	7.
\$1.15	\$ .75	\$ .40	\$ .30	\$1.65	\$2.00	\$20.25

Divide each of these by 3.42:

8.	9.	10.	11.	12.	13.	14.
.75	2.00	1.50	7.182	1.40	.42	.68

(Without pencil.)

I. Read each of these numbers, first as so many hundredths, then as so many percent. Read .16 as "sixteen hundredths or sixteen percent." Read .04 as "four hundredths or four percent." Read .60 as "sixty hundredths or sixty percent."

1. .15	.20	.06	6. .09	.10	.11
2. .18	.75	.08	7. .16	.02	.50
3. .40	.05	.12	8. .70	.05	.28
4. .45	.55	.60	9. .03	.60	.80
5. .07	.30	.90			

II. Examine each of Ex. 10 to 17. Think what the quotient is. Then tell what it is in hundredths. Say 20 hundredths for .2. Say 30 hundredths for .3, etc.

10.	11.	12.	13.
$200 \overline{)72}$	$40 \overline{)8.8}$	$14 \overline{)2.8}$	$\$125 \overline{)\$37.50}$
14.	15.	16.	17.
$\$60 \overline{)\$13.80}$	$15 \overline{)6}$	$\$25 \overline{)\$10.75}$	$110 \overline{)44}$

III. Repeat Ex. 10 to 17. This time, express each quotient as a percent. Say "36 percent" for .36. Say "22 percent" for .22, etc. Say "72 is 36 percent of 200," "8.8 is 22 percent of 40," "2.8 is 20 percent of 14," etc.

IV. Examine Ex. 18 to 26. Think what the missing number is. Then tell what it is. Say "24 is .12 or 12 percent of 200," "14 ft. = .20 or 20 percent of 70 ft.," etc.

18. $24 = \dots \times 200$	22. $12 \text{ ft.} = \dots \times 20 \text{ ft.}$
19. $14 \text{ ft.} = \dots \times 70 \text{ ft.}$	23. $\$7.50 = \dots \times \$15$
20. $69 = \dots \times 300$	24. $6.3\text{¢} = \dots \times 30\text{¢}$
21. $\$12.50 = \dots \times \$25$	25. $8 \text{ mi.} = \dots \times 20 \text{ mi.}$



1. Read, supplying the missing numbers:

- a. 5 percent of 30 means  $\frac{5}{100}$  of 30, or  $.05 \times 30$ , or ...
- b. 6 percent of 30 means  $\frac{6}{100}$  of 30, or  $.06 \times 30$ , or ...
- c. 12 percent of 50 means  $\frac{12}{100}$  of 50, or  $.12 \times 50$ , or ...
- d. 95 percent of 100 means  $.95 \times 100$  or ...
- e. 4 percent of 25 means ...  $\times 25$  or ...
- f. 8 percent of 120 means ...  $\times 120$  or ...
- g. 15 percent of 30 means ...  $\times 30$  or ...
- h. 18 percent of 1000 means ...  $\times 1000$  or ...

(With pencil.)

- 2. Alice and Helen asked Mr. Smith how much he would charge to let them pick blueberries in his pasture. He told them that they must give him 15 percent of what they picked and they agreed. They picked 260 quarts. How many quarts did they give him?
- 3. Their brother Dick carried the berries around to people's houses and sold them for \$26.50 in all. The girls agreed to give him 18 percent of this. How much should they give him?
- 4. How much had they left for themselves?
- 5. Alice and Helen expect to pick 360 quarts of blueberries this summer and to sell 70 percent of them. How many quarts do they expect to sell?

(Without pencil.)

Tell which bar has —

- 6. About 5 percent of its length shaded.
- 7. About 10 percent of its length shaded.
- 8. About 25 percent of its length shaded.
- 9. About 75 percent of its length shaded.
- 10. About 90 percent of its length shaded.
- 11. About 95 percent of its length shaded.

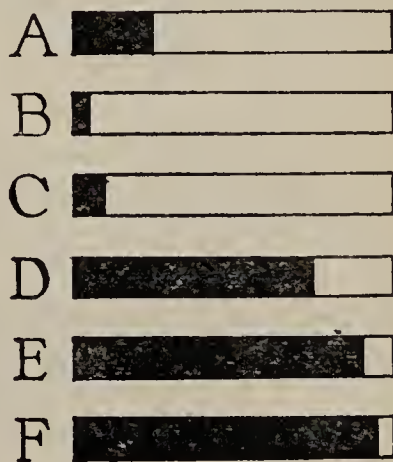



12. Read these lines, supplying the missing numbers:

- a. 7 percent of \$200 or  $.07 \times \$200 = \dots$
- b. 9 percent of \$300 or  $\dots \times \$300 = \dots$
- c. 9 percent of \$30 or  $\dots \times \$30 = \dots$
- d. 11 percent of 600 ft. or  $\dots \times 600 \text{ ft.} = \dots \text{ ft.}$
- e. 12 percent of 200 ft. or  $\dots \times 200 \text{ ft.} = \dots \text{ ft.}$
- f. 12 percent of 20 ft. or  $\dots \times 20 \text{ ft.} = \dots \text{ ft.}$
- g. 18 percent of 100 mi. or  $\dots \times 100 \text{ mi.} = \dots \text{ mi.}$
- h. 14 percent of 100 mi. or  $\dots \times 100 \text{ mi.} = \dots \text{ mi.}$
- i. 65 percent of 100 mi. or  $\dots \times 100 \text{ mi.} = \dots \text{ mi.}$
- j. 50 percent of 100 mi. or  $\dots \times 100 \text{ mi.} = \dots \text{ mi.}$
- k. 4 percent of 200 =
- l. 6 percent of 200 =
- m. 50 percent of 200 =
- n. 25 percent of 200 =
- o. 75 percent of 1000 =
- p. 10 percent of 20 =

We write % for percent. Say "percent" when you read %.

4% of means 4 percent of or  $.04 \times$ .

8% of means 8 percent of or  $.08 \times$ .

70% of means 70 percent of or  $.70 \times$ .

13. State the products:

- a.  $.04 \times \$200$
- b. 5% of 80 miles
- c.  $.25 \times \$3.00$
- d.  $.08 \times 400 \text{ ft.}$
- e. 8% of 200 ft.
- f. 12% of 100 ft.
- g.  $.15 \times 20 \text{ miles}$
- h. 15% of 30 miles
- i. 15% of 100 miles

(With pencil.)

Find the products:

- 14.  $.17 \times 45 \text{ acres}$
- 15. 21 percent of 60 acres
- 16. 45 percent of 325 ft.
- 17. 15 percent of \$28.65
- 18. 18 percent of \$3.25
- 19. 4% of 16,820 pounds
- 20. 95% of 21.4 sq. mi.
- 21. 37% of \$15.00

58. "How Many Hundredths?" or "What Percent?" 191

1. The boys of the Logan Star baseball team expect to win 65 percent of the games they play, losing only 35 percent. (a) How many games do they expect to win out of 20 games played? (b) How many games do they expect to lose out of 20?
2. They played 25 games in all. They won 14; two games were tied; they lost 9. What percent of the 25 games did they win? What percent were tied? What percent of the games did they lose?

*Here is the way to find out:*

$$\begin{array}{r} .56 \\ 25 \overline{)14.00} \\ \underline{12\ 5} \\ 1\ 50 \\ \underline{1\ 50} \end{array} \quad .56 \text{ or } 56 \text{ hundredths of } 25 = 56 \text{ percent of } 25$$

$$\begin{array}{r} .08 \\ 25 \overline{)2.00} \\ \underline{2\ 00} \end{array} \quad .08 \text{ or } 8 \text{ hundredths of } 25 = 8 \text{ percent of } 25$$

$$\begin{array}{r} .36 \\ 25 \overline{)9.00} \\ \underline{7\ 5} \\ 1\ 50 \\ \underline{1\ 50} \end{array} \quad .36 \text{ or } 36 \text{ hundredths of } 25 = 36 \text{ percent of } 25$$

3. The Crescents played 40 games in all. They won 26 and lost 14. What percent of the 40 games did they win? What percent did they lose?
4. The North Side Stars played 20 games, winning 13 and losing 7. What percent of the 20 games did they win? What percent did they lose?
5. The Athletics played 36 games, winning 27 and losing 9. What percent of the 36 games did they win? What percent did they lose?

Each team in the School Boys' League played 20 games.

Team A won 16 and lost 4.

Team G won 10 and lost 10.

Team B won 14 and lost 6.

Team H won 8 and lost 12.

Team C won 13 and lost 7.

Team I won 8 and lost 12.

Team D won 12 and lost 8.

Team J won 5 and lost 15.

Team E won 11 and lost 9.

Team K won 3 and lost 17.

6. What percent of its 20 games did Team A win? Team B? Team C?

7. What percent of its 20 games did each of the other teams win?

The children in Grade 6 had a test of 40 words to spell.

Anne had 34 right.

8. What percent of the 40 words did each girl have right?

Beatrice had 26 right.

Clara had 22 right.

Dorothy had 28 right.

9. What percent of the 40 words did each girl have wrong?

Emma had 30 right.

Grace had 38 right.

10. The children in Grade 6 had a test of 10 problems in arithmetic. Read, supplying the missing percents for each girl:

Anne had 5 right. She had ... % right and ... % wrong or omitted.

R. means *right*. W. or O. means *wrong or omitted*.

Beatrice had 6 right. She had ... % R. and ... % W. or O.

Clara had 7 right. She had ... % R. and ... % W. or O.

Dorothy had 8 right. She had ... % R. and ... % W. or O.

Emma had 9 right. She had ... % R. and ... % W. or O.

11. Read, supplying the missing percents and numbers:

A.

6 is ... percent of 10.

6 is ... percent of 20.

6 is ... percent of 30.

6 is ... percent of 50.

6 is ... percent of 100.

B.

12 is ... percent of 20.

12 is ... percent of 30.

12 is ... percent of 40.

12 is ... percent of 60.

12 is ... percent of 24.

C.

8 % of 120 = ...

8 % of 100 = ...

8 % of 50 = ...

25 % of 100 = ...

25 % of 200 = ...

1. Express each of these percents as a decimal and write  $\times$  for *of*, as is shown in the first line:

a. 4.23% of = .0423 $\times$	i. 84.08% of = .8408 $\times$
b. 16.4% of = . . . . .	j. 69.8% of = . . . . .
c. 18% of = . . . . .	k. 10.09% of = . . . . .
d. 9.25% of = . . . . .	l. 12.06% of = . . . . .
e. 6.8% of = . . . . .	m. 30% of = . . . . .
f. 96.73% of = . . . . .	n. 20.4% of = . . . . .
g. 73.28% of = . . . . .	o. 16.25% of = . . . . .
h. 12.5% of = . . . . .	p. 7.15% of = . . . . .

2. A certain cow gave 1465 lb. milk in July. 4.23 percent of the milk was butter-fat. How many pounds of butter-fat did the cow produce in July?
3. How many games must a baseball team win out of 112 games, in order to win 56.25 percent of the 112?
4. In the second half year the teacher gave a series of tests in spelling, including 250 words in all. Anne had 167 right. What percent of the 250 words did she have right? Look at the work shown below. Then close the book, write  $250 \overline{)167}$ , and find the answer for yourself.

$$\begin{array}{r} .668 \\ 250 \overline{)167.00} \\ \underline{150 \ 0} \\ 17 \ 00 \\ \underline{15 \ 00} \\ 2 \ 000 \\ \underline{2 \ 000} \end{array}$$

$.668 \times$  means 66.8% of.

Check your result by finding whether 66.8% of

250 is 167. Use

$$\begin{array}{r} 250 \text{ or } .668 \\ \underline{.668} \quad \underline{250} \end{array}$$

5. In this long test Beatrice had 211 right; Clara had 216 right. What percent of the 250 words did Beatrice have right? 6. What percent did Clara have right?
7. How much is (a) 4.7% of 124? (b) 96.2% of 508?



194 60. Expressing Percents as Common Fractions

(Without pencil.)

1. Express each "percent of" as a common fraction as shown in the first row. Then multiply.

a.  $66\frac{2}{3}$  percent of 30, or  $\frac{2}{3} \times 30 = 20$ .

b.  $12\frac{1}{2}$  percent of 40, or  $\dots \times 40 = \dots$

c.  $37\frac{1}{2}$  percent of 32, or  $\dots \times 32 = \dots$

d.  $33\frac{1}{3}$  percent of 60, or  $\dots \times 60 = \dots$

e.  $62\frac{1}{2}$  percent of 80, or  $\dots \times 80 = \dots$

f.  $16\frac{2}{3}$  percent of 45, or  $\dots \times 45 = \dots$

g.  $87\frac{1}{2}$  percent of 16, or  $\dots \times 16 = \dots$

2. State the products:

A.

$16\frac{2}{3}\%$  of 150

$33\frac{1}{3}\%$  of 150

$66\frac{2}{3}\%$  of 150

$25\%$  of 800

$75\%$  of 800

B.

$12\frac{1}{2}\%$  of 80

$25\%$  of 80

$37\frac{1}{2}\%$  of 80

$50\%$  of 80

$62\frac{1}{2}\%$  of 80

C.

$16\frac{2}{3}\%$  of \$2.40

$33\frac{1}{3}\%$  of \$2.40

$87\frac{1}{2}\%$  of \$2.40

$75\%$  of \$2.40

$25\%$  of \$2.40

(With pencil.)

Find the products and check results:

3.  $87\frac{1}{2}\%$  of \$36.80. (Use  $\frac{7}{8} \times 36.8$ . Check by  $.875 \times \$36.80$ .)

4.  $66\frac{2}{3}\%$  of \$15.75. (Use  $\frac{2}{3} \times 15\frac{3}{4}$ . Check by  $2 \times \$15.75$ .

Divide the quotient by 3.)

5.  $33\frac{1}{3}\%$  of \$10.50. (Use  $\frac{1}{3} \times 10\frac{1}{2}$ . Check by  $3 \overline{)10.50}$ .)

6.  $12\frac{1}{2}\%$  of \$10.00. 7.  $25\%$  of \$15.00. 8.  $37\frac{1}{2}\%$  of \$18.00.

9.  $33\frac{1}{3}\%$  of \$24.75. 10.  $16\frac{2}{3}\%$  of \$15.00. 11.  $87\frac{1}{2}\%$  of \$20.00.

The boys were practicing shooting with a rifle. Each boy had 24 shots. Dick made 9 hits. Fred made 12. Joe made 15. John made 16. Lewis made 18. Patrick made 21.

12. Find what percent of hits each boy made.

13. Counting that Patrick can hit the mark  $87\frac{1}{2}$  percent of the time, how many hits will he make out of 40 shots?

1. Express each of these fractions as a decimal and as a percent as is done in the first line:

A.	B.	C.
$\frac{1}{50} = .02$ or $2\%$	$\frac{1}{40} = .025$ or $2\frac{1}{2}\%$	$\frac{1}{16} = .0625$ or $6\frac{1}{4}\%$
$\frac{1}{25} = \dots$ or $\dots\%$	$\frac{1}{20} = \dots$ or $\dots\%$	$\frac{1}{8} = \dots$ or $\dots\%$
$\frac{1}{8} = \dots$ or $\dots\%$	$\frac{1}{10} = \dots$ or $\dots\%$	$\frac{1}{4} = \dots$ or $\dots\%$
$\frac{1}{3} = \dots$ or $\dots\%$	$\frac{1}{5} = \dots$ or $\dots\%$	$\frac{3}{4} = \dots$ or $\dots\%$
$\frac{2}{3} = \dots$ or $\dots\%$	$\frac{4}{5} = \dots$ or $\dots\%$	$\frac{3}{8} = \dots$ or $\dots\%$
$\frac{1}{2} = \dots$ or $\dots\%$	$\frac{2}{5} = \dots$ or $\dots\%$	$\frac{7}{8} = \dots$ or $\dots\%$

## Spalding & Co.

For this week we will sell any of the following articles to any boy or girl member of the Public School Athletic Association at 15 percent less than the regular price.

	Reg. Price		Reg. Price
Flexible flyer sleds	\$2.50	Skating shoes	\$4.00
Hockey sticks	.40	Boys' sweaters	\$3.50
Skates, B and B extra	\$1.80	Girls' sweaters	\$4.50

- Find how much Spalding & Co. subtract from the regular price of each of these articles, and how much a member of the association would have to pay for each article.
- Will bought a sled for \$2.13, used it for two winters, and then offered it to Joe for 60 percent of what it cost. Joe offered him a dollar for it. How much more did Will ask than Joe offered?
- Mary bought a pair of skating shoes for \$3.40. Next year she offered to sell them for 25 percent less than what she paid for them. How much did she offer to take off from the \$3.40 and how much money did she ask for the shoes?
- What do you pay for a coat if the regular price is \$9 and you buy it for 20% less than the regular price?

## 62. A Second-Hand Party

The boys and girls in the 6th grade of the Irving School had a *Second-Hand Party*. Each boy and girl brought one article that he wanted to sell and marked it with a tag telling the price he paid for it and the price he would sell it for. First they figured what percent the selling price was of the cost of the article when new, and wrote the percent on the tag. They arranged the articles around the room in a line, beginning with the article that was marked at the lowest percent of the original cost and ending with the article that was marked with the highest percent of the original cost. Then the children who wanted to buy any of the articles did so.

Here are some of the articles and prices. Figure out for each article what percent the selling price is of the cost when new.

	Selling Price Second Hand	Cost When New			
1. Book	30¢	\$1.75	<i>Find quotients only to the nearest thousandth, giving results to the nearest tenth of a percent, as shown below for No. 1.</i>		
2. Skates	25¢	.98			
3. Game	15¢	.49			
4. Racket	40¢	3.25			
5. Picture	17¢	.25			
6. Toy	9¢	.25		17.1%	or 17.1%
7. Doll	15¢	1.25		.171 +	.171 +
8. Sled	25¢	1.75		$1.75 \overline{) 30.000}$ $\begin{array}{r} 175 \\ \underline{1250} \\ 1225 \\ \underline{250} \\ 175 \\ \underline{75} \end{array}$	$175 \overline{) 30.000}$ $\begin{array}{r} 175 \\ \underline{1250} \\ 1225 \\ \underline{250} \\ 175 \\ \underline{75} \end{array}$

Ask your teacher to let you have a *Second-Hand Party*, when you have learned to find percentages quickly and without mistakes.



## 1. Read, supplying the missing numbers:

(Use pencil if you cannot obtain the results mentally.)

A.	B.	C.
20 miles = 50% of ...	\$12 = 25% of ...	15 cents = 10% of ...
20 miles = 10% of ..	12 = 50% of ...	15 cents = 12½% of ...
20 = 66⅔% of ...	12 = 75% of ...	15 cents = 15% of ...
20 = 33⅓% of ...	12 = 16⅔% of ...	15 cents = 16⅔% of ..
20 = 80% of ...	12 = 33⅓% of ...	15 cents = 50% of ...
20 = 40% of ...	12 = 66⅔% of ...	15 cents = 75% of ...

Arrange your written work in Ex. 2 to 12 as neatly as you can. Find the right numbers for the empty spaces. Check each result.

2. \$13.80 = 92 percent of \$...

.92  $\overline{13.80}$  Check by finding 92% of the quotient.

- |                               |                       |
|-------------------------------|-----------------------|
| 3. \$12.47 = 86% of \$...     | 8. 1.75 = 7% of ...   |
| 4. \$3.75 = 15% of \$...      | 9. 7.5 = 6% of ...    |
| 5. 22.75 lb. = 35% of ... lb. | 10. 6.8 = 20% of ...  |
| 6. 43.2 lb. = 4% of ... lb.   | 11. 2.25 = 15% of ... |
| 7. 227.5 A. = 65% of ... A.   | 12. 18 = 10% of ...   |

## 64.

## 1. Copy and supply the missing numbers.

- |                   |                   |                    |
|-------------------|-------------------|--------------------|
| A. 40 = 5% of ... | B. 24 = 2% of ... | C. 12 = 50% of ... |
| 40 = 8% of ...    | 24 = 3% of ...    | 12 = 40% of ...    |
| 40 = 10% of ...   | 24 = 4% of ...    | 12 = 30% of ...    |

## 2. Supply the missing numbers, as in the first two lines.

- | A.                               | B.                             |
|----------------------------------|--------------------------------|
| 15% of 200 = .15 × 200, or 30    | 25% of 40 = .25 × 40, or 10    |
| 115% of 200 = 1.15 × 200, or 230 | 125% of 40 = 1.25 × 40, or 50  |
| 125% of 200 = 1.25 × 200, or ... | 110% of 40 = 1.10 × 40, or ... |
| 150% of 200 = 1.50 × 200, or ... | 120% of 40 = 1.20 × 40, or ... |
| 200% of 200 = 2 × 200, or ...    | 210% of 40 = 2.10 × 40, or ... |
| 210% of 200 = 2.10 × 200, or ... | 310% of 40 = 3.10 × 40, or ... |



## 65. Estimating Percents

1. Name something which weighs about 1 percent of a man's weight.
  2. Something which weighs about 10% of a man's weight.
  3. Something which weighs about 50% of a man's weight.
  4. Something which weighs about 200% of a man's weight.
  5. Something which weighs about 500% of a man's weight.
  6. Alice's little sister weighed 8 lb. when she was born, and weighs 22 lb. now on her first birthday. What percent is her weight now of her weight when she was born?
  7. If she gains 150 percent of 22 lb. in the next five years, how many pounds will she gain, and how much will she weigh on her 6th birthday?
  8. Helen's sister weighed 24 lb. when she was a year old, and gained 125 percent in the next five years. How many pounds did she gain, and how much did she weigh when she was six years old?
  9. Estimate quickly what 205 percent of 650 is, approximately. Then multiply to find exactly what it is.
  10. How near was your estimate to the exact percent?
  11. Estimate quickly what 125 percent of \$15.00 is, approximately. Then find what it is exactly.
  12. How near was your estimate to the exact percent?
  13. Which of these increases in weight about 3 percent?  
Which increases about 100 percent? Which increases about 200 percent? Which increases about 1000%?
- A baby that grows from 7 lb. to  $21\frac{1}{4}$  lb.  
A young tree that grows from 2 lb. to 3.96 lb.  
A girl who grows from 80 lb. to 82.4 lb.  
A calf that grows from 75 lb. to nearly 850 lb.
14. Tell some things that increase about 1000 percent in a year or even more than 1000%.

(Without pencil.)

1. State the numbers that you would use in finding  $3\frac{1}{2}\%$  of \$68,  $6\frac{3}{4}\%$  percent of \$950,  $16\frac{2}{3}\%$  of \$36, and so on, as is done in the first line.

A.	C.
$4\frac{3}{4}\%$ of means .0475 $\times$	$83\frac{1}{3}\%$ of means $.83\frac{1}{3} \times$ or $\frac{5}{6}$ of
$3\frac{1}{2}\%$ of means . . . . .	$66\frac{2}{3}\%$ of means . . . . $\times$ or . . . of
$6\frac{1}{2}\%$ of means . . . . .	$12\frac{1}{2}\%$ of means . . . . $\times$ or . . . of
$5\frac{3}{4}\%$ of means . . . . .	$37\frac{1}{2}\%$ of means . . . . $\times$ or . . . of
$2\frac{1}{2}\%$ of means . . . . .	$25\%$ of means . . . . $\times$ or . . . of
$4\frac{3}{4}\%$ of means . . . . .	$75\%$ of means . . . . $\times$ or . . . of
B.	D.
$1\frac{1}{2}\%$ of means . . . . .	$16\frac{2}{3}\%$ of means . . . . $\times$ or . . . of
$4\frac{1}{4}\%$ of means . . . . .	$62\frac{1}{2}\%$ of means . . . . $\times$ or . . . of
$2\frac{3}{4}\%$ of means . . . . .	$87\frac{1}{2}\%$ of means . . . . $\times$ or . . . of
$18\frac{1}{2}\%$ of means . . . . .	$33\frac{1}{3}\%$ of means . . . . $\times$ or . . . of

(With pencil.)

2. First find the exact result. Then express the result to the nearest cent or pound or bushel.

a. $3\frac{1}{2}\%$ of \$61.27.	i. $316\%$ of 750 lb.	q. $175\%$ of 1000 bu.
b. $4\frac{1}{2}\%$ of \$75.00.	j. $6\%$ of \$125.00.	r. $66\frac{2}{3}\%$ of \$9.50.
c. $3\frac{1}{4}\%$ of \$39.50.	k. $2\frac{1}{3}\%$ of \$14.75.	s. $2\frac{1}{4}\%$ of \$16.27.
d. $5\frac{1}{2}\%$ of \$136.00.	l. $3\frac{3}{4}\%$ of \$28.40.	t. $4\frac{3}{4}\%$ of \$1000.
e. $87\frac{1}{2}\%$ of \$15.00.	m. $75\%$ of \$6.75.	u. $83\frac{1}{3}\%$ of \$8.40.
f. $33\frac{1}{3}\%$ of 296 lb.	n. $37\frac{1}{2}\%$ of 12,864 bu.	v. $62\frac{1}{2}\%$ of 1275 lb.
g. $210\%$ of \$250.	o. $135\%$ of 12,864 bu.	w. $150\%$ of 856 lb.
h. $360\%$ of 475 bu.	p. $156\%$ of 931 bu.	x. $225\%$ of 728 lb.

3. Find the products. Find them mentally, if you can.

A.	B.	C.
$6\%$ of \$15.00 =	$7\%$ of \$400 =	$120\%$ of \$7.00 =
$33\frac{1}{3}\%$ of \$15.00 =	$75\%$ of \$400 =	$90\%$ of \$6.00 =
$150\%$ of \$15.00 =	$250\%$ of \$400 =	$15\%$ of \$300.00 =
$300\%$ of \$15.00 =	$600\%$ of \$400 =	$87\frac{1}{2}\%$ of \$2 =

Mary picks berries. Her brother Fred sells them for her. He receives 10 percent of what the people pay for the berries.

1. How much does he receive for the sale of 16 quarts at 2 qt. for 25¢? How much is left for Mary?
2. How much does Fred receive when he sells 12 qt. at 15¢ per qt.? How much is left for Mary?
3. Play "Commission Merchant" in this way. One child is the farmer. Another child is the commission merchant. One other child is the buyer. The farmer says, "*I have 20 barrels of apples [or 12, or 15, or some other number, or bushels of potatoes, or crates of berries, or anything he has to sell]. I will give you 6 percent [or 4 percent or 5 percent or 3½ percent or 12½% or any reasonable percent] of what you sell them for.*" The commission merchant agrees on the percentage he is to receive, and writes on the blackboard, "*I have for sale 20 barrels of fine Baldwin apples at \$2.50 a barrel*" [or \$2.25 or \$3.10 or \$2.75 or any reasonable price]. The buyer says, "*I will take 9 barrels*" [or 8 or 10 or any other number of barrels]. He writes his name on the blackboard and the number of barrels that he buys. Then another buyer has a chance to buy what he needs until all 20 barrels are sold. All the children in the class find out (a) how much each buyer must pay the commission merchant, (b) how much the commission merchant should keep for himself, and (c) how much he should send to the farmer.

Then other children act as farmer, commission merchant, and buyers.



## 68. Receipts, Gains, and Losses, Expressed as Percents 201

(Do as much of the work mentally as you can.)

Henry bought three puppies for \$2 each. He called them Bobs, Mops, and Giant. The very next day he sold Bobs for \$3.00, Mops for \$6.00, and Giant for \$3.50.

1. How much was his gain or profit on Bobs? On Mops? On Giant?
2. What percent of the cost (\$2.00) was his profit on each dog?
3. Find the number of dollars gained and the percent that the gain is of the cost price as is done in the first line.

	Amount Gained	Percent of Cost Price Gained
Bought a dog for \$8.00, sold it for \$10.00	\$2.00	25
a. Bought a horse for \$100.00, sold it for \$140.00	....	..
b. Bought a horse for \$250.00, sold it for \$275.00	....	..
c. Bought a cow for \$75.00, sold it for \$100.00	....	..
d. Bought a kitten for \$12.00, sold it for \$20.00	....	..
e. Bought a dog for \$1.00, sold it for \$5.00	....	..

4. Tell the missing numbers:

Adolphus bought a dog for \$10.00, hoping to sell it for more.

- a. First he offered it for 100% more than he paid or ....
- b. Then he offered it for 80% more than he paid or ....
- c. Then he offered it for 60% more than he paid or ....
- d. Then he offered it for 40% more than he paid or ....
- e. Then he offered it for 25% more than he paid or ....
- f. Then he offered it for 15% more than he paid or ....
- g. Then he offered it for 10% more than he paid or ....
- h. Then he offered it for the same price as he paid or ....
- i. Then he offered it for 5% less than he paid or ....
- j. Then he offered it for 10% less than he paid or ....
- k. Then he offered it for 30% less than he paid or ....  
and sold it.



The whole of any amount =  $10\%_{100}$  of it or  $1.00 \times$  it or  $100\%$  of it.

(Use pencil if you need to.)

1. The Crescents won  $62\frac{1}{2}\%$  of the games they played and were tied in  $6\frac{1}{4}\%$ . What percent of the games played did they lose?
2. Alice had  $8\%$  of the words in a spelling test wrong or omitted. What percent of the words did she have right?
3. Mary expects to sell 75 percent of the eggs from her hens, give away 10 percent, and keep the rest for cooking. What percent of the eggs does she expect to keep for cooking?
4.  $56\frac{1}{4}$  percent of the class tried a problem and succeeded.  $18\frac{3}{4}$  percent tried it and failed. What percent did not even try the problem?
5. Make two problems about adding and subtracting percents for the other children to solve.

(Without pencil.)

6. Supply the missing numbers, as is done in the first line:
  - a.  $10\%$  less than cost =  $90\%$  of the cost.
  - b.  $12\frac{1}{2}\%$  less than cost = ... % of the cost.
  - c.  $16\frac{2}{3}\%$  more than cost = ... % of the cost.
  - d.  $20\%$  more than cost = ... % of the cost.
  - e.  $25\%$  less than cost = ... % of the cost.

### 70. Fixing Prices

(Write the answers. Do as much of the work as you can mentally.)

Rebecca's father buys and sells second-hand schoolbooks.

He pays  $50\%$  of the regular price for a book in excellent condition.

“	“	$40\%$	“	“	“	“	“	“	“	“	good	“
“	“	$25\%$	“	“	“	“	“	“	“	“	fair	“
“	“	$10\%$	“	“	“	“	“	“	“	“	poor	“

I. How much does he pay for each of these books:

	Regular Price	Condition
1. Arithmetic	\$ .65	poor
2. Geography	.90	excellent
3. U. S. History	1.10	good
4. Spelling-Book	.30	poor
5. Physiology	.55	excellent
6. U. S. History	1.10	fair
7. Arithmetic	.65	excellent
8. Geography	.90	poor
9. Ancient History	1.15	good
10. Latin Grammar	.95	poor
11. German Grammar	1.05	fair
12. Geography	.90	fair
13. Arithmetic	.65	good
14. Algebra	.85	excellent
15. Song Book	.40	good
16. Arithmetic	.65	fair

He counts on getting on the average for a book —  
 in excellent condition,  $66\frac{2}{3}\%$  of the regular price.  
 in good condition, 50 % of the regular price.  
 in fair condition,  $33\frac{1}{3}\%$  of the regular price.  
 in poor condition, 20 % of the regular price.

II. How much does he count on receiving on the average for each of the books described in Ex. 1 to 16?

III. How many cents does he gain on a book that he buys for 36 cents and sells for 45 cents? What percent of the cost price does he gain? What percent of the selling price does he gain?

IV. What percent of the cost price does he gain on a book that he buys for 50 cents and sells for 65 cents?

When an article is sold at less than the price stated in the catalogue or bill, we say that it is sold at a *discount*, or reduction in price. When an article is sold at more than the price stated in the catalogue or bill, we say that it is sold at an *advance* or increase in price.

1. What would you really have to pay for each of these articles?

Catalogue Price		Catalogue Price
a. \$8.00, discount 25%		g. \$12.00, advance 10%
b. 6.00, advance 10%		h. .60, discount 16 $\frac{2}{3}$ %
c. 2.00, advance 15%		i. 1.50, discount 20%
d. .75, discount 33 $\frac{1}{3}$ %		j. .80, discount 37 $\frac{1}{2}$ %
e. 1.80, discount 25%		k. 4.00, advance 15%
f. 25.00, discount 40%		l. 24.00, discount 30%

Sometimes merchants give a small discount for cash.

2. How much would you really have to pay in settling each of these bills, if you paid cash?

a. \$10.42 less 2% for cash.	d. \$64.70 less 1% for cash.
b. 9.63 less 1 $\frac{1}{2}$ % for cash.	e. 87.25 less 1% for cash.
c. 280.00 less 1 $\frac{1}{2}$ % for cash.	f. 312.48 less 3% for cash.

3. In *a*, *b*, *c*, *d*, and *e* below, find how much less you pay for a dozen articles bought at one time than you would pay if you bought them one at a time. Then find what percent discount is given for buying by the dozen.

- When the price is 10¢ for one article and \$1.00 per dozen.
- When the price is 15¢ for one article and \$1.32 per dozen.
- When the price is 12 $\frac{1}{2}$ ¢ for one article and \$1.30 per dozen.
- When the price is 32¢ for one article and \$3.36 per dozen.
- When the price is 20¢ for one article and \$2.25 per dozen.



1. Alice, Bertha, Grace, and Helen shared the cost of a sewing machine. They paid \$18.95 for the machine and \$1.15 expressage. Alice paid \$6.05, Bertha paid \$5.65, Grace paid \$4.60, Helen paid \$3.80. What percent of the total cost did each girl pay?
2. The girls kept account of how many hours each used the machine the first year. Alice used it 285 hr. Bertha used it 223 hr. Grace used it 198 hr. Helen used it 174 hr. (a) How much did they use it in all? (b) What was the number of hours of use of the machine per month? (c) What was the average number of hours of use per month by one girl?
3. They used it for two years and then sold it to some younger girls for exactly 30% below the \$20.10 which it cost. What did they receive for it?
4. They estimated that they had used it for 1600 hours, during the two years. How much did it cost them per hour for the use of the machine?
5. They disagreed about how to divide the \$14.07 they received for the machine. Some thought that Alice ought to receive ...% of the \$14.07, Bertha ...% of it, Grace ...% of it, and Helen ...% of it, because they had paid in that proportion. But Alice said, "Some of us have used it more than others, and that should be taken into account." Finally they decided to give Alice 28% of the \$14.07, to give Bertha 26%, to give Grace 24%, and to give Helen 22%. How much did each girl receive?
6. Divide \$25 among three persons, giving 65% to No. I, 20% to No. II, and the remainder to No. III.
7. Divide \$3.60 among four persons, giving 40% to A., 30% to B., 20% to C., and 10% to D.



If you put money in a savings bank and leave it for six months or a year, the bank will pay back what you put in and some more besides. The extra money which the bank pays for the use of your money is called *interest*.

1. Why do boys and girls put money in a savings bank?
2. What else does a savings bank do for you besides prevent you from spending the money and keep the money from being lost or stolen?

Interest is money paid for the use of money.

If you leave money with the Empire Bank for six months, the bank will pay back what you put in and 2 percent more.

3. Read, supplying the missing numbers as is done in the first line. Do not use pencil and paper unless you need to.
  - a. If \$18 is left for 6 mo., the bank will pay back \$18 and \$.36 interest.
  - b. If \$10 is left for 6 mo., the bank will pay back \$10 and ...
  - c. If \$20 " " " " " " " 20 and ...
  - d. If \$25 " " " " " " " 25 and ...
  - e. If \$9 " " " " " " " 9 and ...
  - f. If \$7.50 " " " " " " " 7.50 and...
  - g. If \$5 " " " " " " " 5 and ...
  - h. If \$8 " " " " " " " 8 and ...
4. Mr. Richards built a house that cost \$2800. He had saved \$2000 toward it. He borrowed the rest from Mr. Ames. How much did he borrow?
5. He pays Mr. Ames 6 percent interest on \$800 every year. How many dollars does he pay Mr. Ames every year?
6. How much is  $\$1.00 + 4\%$  of  $\$1.00$ ?
7. How much is  $\$6.00 + 2\%$  of  $\$6.00$ ?
8. How much is  $\$100.00 + 5\%$  of  $\$100.00$ ?

*(Write the answers. Do not write any other numbers unless you need to.)*

1. John hoed 400 sq. ft. in his garden in an hour. Then he sharpened his hoe and hoed 600 sq. ft. in an hour. What percent did he gain by sharpening his hoe?
2. Nell tried 10 problems and had only 5 right. Then Alice explained the work and Nell tried 10 more problems. She had 9 right. What percent did she gain by having the work explained?
3. Mary put \$25 in the bank for a year. The bank paid her 4% interest. How much did she have at the end of the year?
4. At 4% for a year, what would the interest for \$15 be if it was left in the bank only six months?
5. What will you have to pay for an article whose catalogue price is \$7.50 if a discount of 20% is given?
6. What percent advance in price is made when you raise the price from 20¢ to 25¢?
7. How much more interest do you get in a year on \$20 at 4% than on \$20 at 3½% per year?
8. Ellen's father lets her have land for a garden and pays for the seed and fertilizer. Ellen does the work. She gives him 15% of what she receives for vegetables. Last year she sold just 30 dollars worth. (a) How much should she pay her father? (b) How much will she have left? (c) What percent of the receipts from sales of vegetables does she have for herself?
9. John was asked how many games his ball team had played. He said, "I don't remember, but I know that we won 12 games, and that we won exactly 60 percent of the games we played." How could John have found out how many games his team had played? How many had it played?

## 208 75. Keeping Accounts of Receipts and Expenditures

One child tells her receipts and expenditures like this:

“Play that I am Helen, a rich man’s daughter. It is Monday. I have \$6.52 brought forward from last week. I receive an allowance of \$1.00 for the week. My Uncle Roger gives me \$2.00 Wednesday. On Tuesday I spend 50¢ for a book, and 30¢ for a violin string. On Thursday I buy 4 sundaes for 10¢ each. On Saturday I spend \$1.50 to go to a concert. On Sunday I give 10¢ at Sunday school.”

The other children write out Helen’s accounts for the week, as fast as she tells what she received and spent, and find how much money she has left at the end of the week.

Then some child plays that he is an energetic boy who earns much money in all sorts of ways, and tells what his receipts and expenditures for a week might be.

Then some child plays that she is an excellent singer who receives money for singing at concerts and spends money for music and music lessons.

The other children write out the accounts as fast as they hear what the person received and spent.

Practice with these sums so that you can play the game well.

1.	2.	3.	4.	5.	6.	7.	8.
7.16	5.08	9.12	8.31	4.16	.72	3.70	4.96
7.69	1.08	1.98	9.33	9.54	3.95	4.94	8.64
.75	.22	.49	.36	1.25	.68	.70	.18
.48	.33	.95	1.00	.42	.27	.65	4.49
2.65	6.18	.36	.56	.88	7.48	6.21	.42
.54	.45	9.10	.88	.36	1.30	.34	1.32
.56	2.25	.21	8.75	.92	2.18	1.75	.95
.33	.42	1.20	7.56	8.56	.97	1.40	5.68
5.24	.95	.92	1.10	.95	9.36	.45	1.88



An Inventory is a list of things.

An Appraisal is a statement of how much money a thing is worth.

1. Fred made this inventory and appraisal of his tools. Examine it.

	Cost When New	Present Condition	Take Off for Wear and Tear	Present Value
1 hammer	\$ .45	fair	40%	.27
1 saw	.60	fair	$\frac{1}{3}$	.40
1 plane	1.00	fair	30%	.70
1 bit-brace	1.20	almost new	10%	1.08
Set of bits	1.00	poor	50%	.50
1 mallet	.25	good	$\frac{1}{5}$	.20
Chisels, about	.80	good	25%	.60
Odds and ends, about	.75	fair	$\frac{1}{3}$	.50
Total	....			...

2. Find the total cost when new and total present value of Fred's tools.
3. Play Inventory and Appraisal in this way:  
One child tells the things and what they cost when new and what condition each is in. Another child tells what fraction or percent to take off for wear and tear for each thing. The rest of the class write down what is said and find the present value.
4. Write a real or make-believe inventory and appraisal of—
  - a. The furniture of a bedroom.
  - b. A child's toys.
  - c. The books belonging to a girl or boy.
  - d. The contents of your schoolroom.



1. Mr. Thomas has a tag on each piece of cloth in his store to show how much of it has been sold and how much there is left in the piece. When a clerk sells  $3\frac{3}{8}$  yd., she writes  $3\frac{3}{8}$  under *Sales*. Under *Stock* is written each month the number of yards left in the piece. Examine Tag I. Then find the total number of yards sold and the number of yards left on Jan. 1 for each of the other pieces. Enter the results neatly as shown below.

<p>I. Piece 22 A4</p> <table style="width: 100%; border-collapse: collapse;"> <thead> <tr> <th style="width: 50%; text-align: left;"><i>Stock</i></th> <th style="width: 50%; text-align: left;"><i>Sales</i></th> </tr> </thead> <tbody> <tr> <td>Dec. 1 <math>24\frac{1}{2}</math></td> <td><math>3\frac{3}{8}</math></td> </tr> <tr> <td></td> <td><math>7\frac{1}{4}</math></td> </tr> <tr> <td></td> <td><math>2\frac{3}{4}</math></td> </tr> <tr> <td></td> <td><u>4</u></td> </tr> <tr> <td style="text-align: right;"><math>17\frac{3}{8}</math> Tot.</td> <td><math>17\frac{3}{8}</math></td> </tr> <tr> <td>Jan. 1 <math>7\frac{1}{8}</math></td> <td></td> </tr> </tbody> </table>	<i>Stock</i>	<i>Sales</i>	Dec. 1 $24\frac{1}{2}$	$3\frac{3}{8}$		$7\frac{1}{4}$		$2\frac{3}{4}$		<u>4</u>	$17\frac{3}{8}$ Tot.	$17\frac{3}{8}$	Jan. 1 $7\frac{1}{8}$		<p>II. Piece 40 A1</p> <table style="width: 100%; border-collapse: collapse;"> <thead> <tr> <th style="width: 50%; text-align: left;"><i>Stock</i></th> <th style="width: 50%; text-align: left;"><i>Sales</i></th> </tr> </thead> <tbody> <tr> <td>Dec. 1 40</td> <td><math>6\frac{1}{2}</math></td> </tr> <tr> <td></td> <td><math>4\frac{3}{4}</math></td> </tr> <tr> <td></td> <td><math>5\frac{1}{4}</math></td> </tr> <tr> <td></td> <td><u><math>1\frac{1}{8}</math></u></td> </tr> <tr> <td style="text-align: right;">_____ Tot.</td> <td></td> </tr> <tr> <td>Jan. 1 _____</td> <td></td> </tr> </tbody> </table>	<i>Stock</i>	<i>Sales</i>	Dec. 1 40	$6\frac{1}{2}$		$4\frac{3}{4}$		$5\frac{1}{4}$		<u><math>1\frac{1}{8}</math></u>	_____ Tot.		Jan. 1 _____		<p>III. Piece 62 B2</p> <table style="width: 100%; border-collapse: collapse;"> <thead> <tr> <th style="width: 50%; text-align: left;"><i>Stock</i></th> <th style="width: 50%; text-align: left;"><i>Sales</i></th> </tr> </thead> <tbody> <tr> <td>Dec. 1 <math>32\frac{3}{8}</math></td> <td><math>2\frac{5}{8}</math></td> </tr> <tr> <td></td> <td><math>1\frac{7}{8}</math></td> </tr> <tr> <td></td> <td><math>1\frac{1}{4}</math></td> </tr> <tr> <td></td> <td><u>3</u></td> </tr> <tr> <td style="text-align: right;">_____ Tot.</td> <td></td> </tr> <tr> <td>Jan. 1 _____</td> <td></td> </tr> </tbody> </table>	<i>Stock</i>	<i>Sales</i>	Dec. 1 $32\frac{3}{8}$	$2\frac{5}{8}$		$1\frac{7}{8}$		$1\frac{1}{4}$		<u>3</u>	_____ Tot.		Jan. 1 _____	
<i>Stock</i>	<i>Sales</i>																																											
Dec. 1 $24\frac{1}{2}$	$3\frac{3}{8}$																																											
	$7\frac{1}{4}$																																											
	$2\frac{3}{4}$																																											
	<u>4</u>																																											
$17\frac{3}{8}$ Tot.	$17\frac{3}{8}$																																											
Jan. 1 $7\frac{1}{8}$																																												
<i>Stock</i>	<i>Sales</i>																																											
Dec. 1 40	$6\frac{1}{2}$																																											
	$4\frac{3}{4}$																																											
	$5\frac{1}{4}$																																											
	<u><math>1\frac{1}{8}</math></u>																																											
_____ Tot.																																												
Jan. 1 _____																																												
<i>Stock</i>	<i>Sales</i>																																											
Dec. 1 $32\frac{3}{8}$	$2\frac{5}{8}$																																											
	$1\frac{7}{8}$																																											
	$1\frac{1}{4}$																																											
	<u>3</u>																																											
_____ Tot.																																												
Jan. 1 _____																																												
<p>IV. Piece 62 B3</p> <table style="width: 100%; border-collapse: collapse;"> <thead> <tr> <th style="width: 50%; text-align: left;"><i>Stock</i></th> <th style="width: 50%; text-align: left;"><i>Sales</i></th> </tr> </thead> <tbody> <tr> <td>Dec. 1 <math>29\frac{1}{4}</math></td> <td><math>3\frac{1}{4}</math></td> </tr> <tr> <td></td> <td>2</td> </tr> <tr> <td></td> <td><u><math>4\frac{1}{2}</math></u></td> </tr> <tr> <td style="text-align: right;">_____ Tot.</td> <td></td> </tr> <tr> <td>Jan. 1 _____</td> <td></td> </tr> </tbody> </table>	<i>Stock</i>	<i>Sales</i>	Dec. 1 $29\frac{1}{4}$	$3\frac{1}{4}$		2		<u><math>4\frac{1}{2}</math></u>	_____ Tot.		Jan. 1 _____		<p>V. Piece 70 A</p> <table style="width: 100%; border-collapse: collapse;"> <thead> <tr> <th style="width: 50%; text-align: left;"><i>Stock</i></th> <th style="width: 50%; text-align: left;"><i>Sales</i></th> </tr> </thead> <tbody> <tr> <td>Dec. 1 <math>41\frac{3}{4}</math></td> <td><math>7\frac{3}{4}</math></td> </tr> <tr> <td></td> <td>8</td> </tr> <tr> <td></td> <td><u><math>9\frac{3}{4}</math></u></td> </tr> <tr> <td style="text-align: right;">_____ Tot.</td> <td></td> </tr> <tr> <td>Jan. 1 _____</td> <td></td> </tr> </tbody> </table>	<i>Stock</i>	<i>Sales</i>	Dec. 1 $41\frac{3}{4}$	$7\frac{3}{4}$		8		<u><math>9\frac{3}{4}</math></u>	_____ Tot.		Jan. 1 _____		<p>VI. Piece 70 B</p> <table style="width: 100%; border-collapse: collapse;"> <thead> <tr> <th style="width: 50%; text-align: left;"><i>Stock</i></th> <th style="width: 50%; text-align: left;"><i>Sales</i></th> </tr> </thead> <tbody> <tr> <td>Dec. 1 <math>31\frac{5}{8}</math></td> <td><math>6\frac{1}{2}</math></td> </tr> <tr> <td></td> <td>5</td> </tr> <tr> <td></td> <td><u><math>4\frac{3}{4}</math></u></td> </tr> <tr> <td style="text-align: right;">_____ Tot.</td> <td></td> </tr> <tr> <td>Jan. 1 _____</td> <td></td> </tr> </tbody> </table>	<i>Stock</i>	<i>Sales</i>	Dec. 1 $31\frac{5}{8}$	$6\frac{1}{2}$		5		<u><math>4\frac{3}{4}</math></u>	_____ Tot.		Jan. 1 _____							
<i>Stock</i>	<i>Sales</i>																																											
Dec. 1 $29\frac{1}{4}$	$3\frac{1}{4}$																																											
	2																																											
	<u><math>4\frac{1}{2}</math></u>																																											
_____ Tot.																																												
Jan. 1 _____																																												
<i>Stock</i>	<i>Sales</i>																																											
Dec. 1 $41\frac{3}{4}$	$7\frac{3}{4}$																																											
	8																																											
	<u><math>9\frac{3}{4}</math></u>																																											
_____ Tot.																																												
Jan. 1 _____																																												
<i>Stock</i>	<i>Sales</i>																																											
Dec. 1 $31\frac{5}{8}$	$6\frac{1}{2}$																																											
	5																																											
	<u><math>4\frac{3}{4}</math></u>																																											
_____ Tot.																																												
Jan. 1 _____																																												

Piece	Dec. Sales	Stock Jan. 1
I. 22 A4	$17\frac{3}{8}$	$7\frac{1}{8}$
II. 40 A1	.....	.....
III. 62 B2	.....	.....
IV. 62 B3	.....	.....
V. 70 A	.....	.....
VI. 70 B	.....	.....

Twice a year Mr. Thomas makes a list of his pieces of cloth telling how long each piece of cloth is and how much it is worth. Sarah helps him. He tells her how long a piece is and how much it is worth per yard. She writes down what the whole piece is worth.

Find what each of these pieces is worth:

Piece Number	Length in Yards	Value per Yd.	Piece Number	Length in Yards	Value per Yd.
103 A	$26\frac{1}{2}$	34¢	308 A	$15\frac{1}{8}$	\$1.12
104 A	$19\frac{1}{2}$	38¢	308 B	$14\frac{3}{8}$	\$1.04
107 A	$14\frac{1}{4}$	36¢	309 A	$21\frac{3}{4}$	.96
107 B	27	39¢	311 C	$5\frac{7}{8}$	\$1.20
107 C	$31\frac{3}{4}$	40¢	316 A	9	\$1.35

## 79.

Study problems 1 to 27. Then write the missing numbers in a column, numbering them 1 to 27. When the teacher reads the correct results, mark each of your results *r* if it is right, *w* if it is wrong.

- 5% of \$35 = ...
- 24 = ... % of 60
- 10 = 50% of ...
- $\frac{1}{2}$  means ... %
- $\frac{1}{3}$  means ... %
- \$80 + 6% of \$80 ...
- 7 = ... % of 10
- $\frac{3}{8}$  of means ... % of
- 6% of 40 in. = ... in.
- 8% of \$12 = ...
- $\frac{1}{5}$  means ... %
- $\frac{3}{5}$  means ... %
- 9% of means ... ×
- 84% of means ... ×
- 145% of means ... ×
- 450 less 2% = ...
- 3% of \$9 = ...
- $66\frac{2}{3}$ % of 18 = ...
- 18 = ... % of 20
- 18 = ... % of 30
- 18 = ... % of 40
- 8 = 10% of ...
- 40¢ = 4% of ...
- $1\frac{1}{2}$ × = ... % of
- 3× = ... % of
- 7% of 80 lb. = ... lb.
- 11% of 60 lb. = ... lb.

1. Here are some records made in a 6th-grade class in the Jefferson School, with the 27 problems of page 211.

Find the percent done by each pupil and the percent correct of those that were done, as shown for Alice and Charles. Be careful to divide by the right number. Copy the table and put in the right percentages in the last two columns.

	Number Done in 2 Min.	Number Correct	Percent Done of the Number to be Done	Percent Correct of the Number Done
Alice	26	24	96.3	92.3
Charles	19	17	70.4	89.5
Dick	24	21	....	....
Edna	20	19	....	....
Edward	15	13	....	....
George	27	23	....	....
Grace	21	20	....	....
Helen	23	22	....	....

### Percentage means percent

- Which pupil had the highest percentage correct of the number done?
- How much higher was Helen's percent correct than Alice's?
- Which boy was higher in percent done out of 27, George or Charles? How much higher?
- Which boy was higher in percent correct, George or Charles? How much higher?
- In four tests Alice had as percentages correct, 92.3, 90.6, 95.4, and 98. What was her average percent correct?
- What gives the higher percentage correct, 21 examples correct out of 24 or 26 examples correct out of 30?

1. Examine Table I. Read Table I, saying, "Cobb was at bat 563 times, made a base hit 208 times, made a sacrifice hit 9 times, and was given his base on balls 118 times. Collins was at bat 521 times, made a base hit 173 times, etc."

TABLE I

## RECORDS OF AMERICAN LEAGUE PLAYERS FOR 1915

A.B. means the number of times the players were at bat.

B.H. means the number of base hits that the player made.

S.H. means the number of sacrifice hits that the player made.

B.B. means the number of bases on balls that the player received.

	A.B.	B.H.	S.H.	B.B.
Cobb.....	563	208	9	118
Collins.....	521	173	35	119
Speaker.....	547	176	17	81
Fournier....	422	136	13	64
McInnis....	456	143	11	14
Veach.....	569	178	18	68

2. What does A.B. mean? What does B.H. mean?  
What does S.H. mean?
3. Copy Table II. Examine it to find out what it means.  
Then write the missing percents for Collins, Speaker, Fournier, McInnis, and Veach.

TABLE II

## RECORDS OF AMERICAN LEAGUE PLAYERS FOR 1915

	% Which B.H. Is of A.B.	% Which S.H. Is of A.B.	% Which B.B. Is of A.B.
Cobb.....	36.9	1.6	21.0
Collins.....	...	...	....
Speaker.....	...	...	....
Fournier.....	...	...	....
McInnis.....	...	...	....
Veach.....	...	...	....



1. Play that you are a teacher who has to mark the percentages correct on each of hundreds of tests. The teacher would make out a table like this to help her. Study this table to see how it is made. Then complete it.

PERCENTS CORRECT CORRESPONDING TO DIFFERENT NUMBERS OF PROBLEMS CORRECT OUT OF A CERTAIN NUMBER DONE

		Number of Problems Done								
		4.	5.	6.	7.	8.	9.	10.	11.	12.
Number Correct	1.	25	20	16.7	14.3					
	2.	50	40	33.3	28.6					
	3.	75	60	50						
	4.	100	80	66.7						
	5.		100	83.3						
	6.			100						
	7.									
	8.									
	9.									
	10.									
	11.									
	12.									

2. In order to have 75% correct, how many problems must you have right out of 8? Out of 12? Out of 4? Out of 16? Out of 20?
3. In order to have 80% correct, how many problems must you have right out of 5? Out of 15? Out of 20?
4. A girl had 62½% of her work correct. What percent of it was wrong?
5. A boy had 83⅓% of his work correct. What percent of it was wrong?
6. In a spelling test Dick omitted 8% of the words and had 14% of the words wrong. What percent did he have right?

Study these 20 problems. Then write the missing numbers in a column, numbering them 1 to 20. When the correct results are read, mark each of your results  $r$  if it is right,  $w$  if it is wrong. If any result is wrong, find what your mistake was.

1. 1.50 less 10% discount = ...
2. 48¢ plus 25% advance = ...
3. The interest on \$14 for a year at 4% = ...
4. The interest on \$30 for a year at 4% = ...
5. The interest on \$15 for 6 mo. at 4% per year = ...
6. If cost price is 20¢ and selling price is 30¢, the gain is ... % of the cost price.
7. If cost price is 20¢ and selling price is 15¢, the loss is ... % of the cost price.
8. If Dick has 24 hits and 6 misses, he has ... % of hits, and ... % of misses.
9. If Joe has 15 hits out of 20 shots, he has ... % of hits.
10. If Alice has 14 words right and 6 words wrong or omitted, she has ... % right and ... % wrong or omitted.
11. An \$8 article at a reduction of 15% sells for ...
12. A bill for \$18 less 2% for cash amounts to ...
13. \$25 left in the bank for a year, with interest at 4 percent, amounts to ...
14. Advancing the price from 20¢ to 24¢ advances it by ... % (of 20¢).
15. Reducing the price from 20¢ to 18¢ reduces it by ... % (of 20¢).
16. 6% per year is at the same rate as ... % for 6 mo.
17. 4% per year is at the same rate as ... % for 6 mo.
18. The interest on \$7.50 for 6 mo. at 4% per year is ...
19. A boy weighs 80 lb. Jan. 1, 1916. If he gains 10% in a year, how much will he weigh Jan. 1, 1917?
20. \$100 is 25 percent of ...

## 84. Common Measures

1. Name 3 things that are measured in inches.
2. Name 3 things that are measured in feet.
3. Name 3 things that are measured in yards.
4. Name 3 things measured in rods. In miles. In sq. in.  
In sq. ft. In sq. rd. In sq. mi. In A. In cu. ft.  
In cu. yd. In pt. In qt. In gal. In barrels.  
In pk. In bu. In tons. In lb. In oz. In sec.  
In min. In hr.

## 85.

1. What fraction of a yard wide is cloth that is (a) 27 in. wide? (b) 30 in. wide? (c) 42 in. wide? (d) 54 in. wide? (e) 45 in. wide?
2. How much cloth is there in a remnant  $3\frac{3}{4}$  yd. long and 27 in. wide? Express the width as a fraction of a yard. Express the result as a mixed number of sq. yd.
3. How much cloth is there in a remnant  $4\frac{1}{8}$  yd. long and 54 in. wide?
4. Which contains more cloth, a remnant  $4\frac{1}{2}$  yd. long and 30 in. wide or a remnant 4 yd. long and 1 yd. wide? How did you express the 30 in.?
5. Which contains more cloth, a remnant  $5\frac{1}{4}$  yd. long and 54 in. wide or a remnant  $6\frac{1}{2}$  yd. long and 45 in. wide? How do you express the 54 in. and the 45 in.?  
Remnant I is  $3\frac{7}{8}$  yd. long and 54 in. wide.  
Remnant II is  $4\frac{3}{8}$  yd. long and 45 in. wide.  
Remnant III is  $4\frac{5}{8}$  yd. long and 42 in. wide.  
Remnant IV is  $6\frac{5}{8}$  yd. long and 30 in. wide.  
Remnant V is  $7\frac{5}{8}$  yd. long and 27 in. wide.
6. (a) Which remnant has the most cloth? (b) Which has the next most? (c) Which is next in size? (d) Which has next to least? (e) Which has the least?



- |             |   | Height in Inches   |                  |                        |                       |               |             |             |             |              |           |             |              |       |        |              |      |      |           |      |       |      |       |      |       |             |  |
|-------------|---|--|------------------|------------------------|-----------------------|---------------|-------------|-------------|-------------|--------------|-----------|-------------|--------------|-------|--------|--------------|------|------|-----------|------|-------|------|-------|------|-------|-------------|--|
|             |   | On 10th Birthday   | On 15th Birthday |                        |                       |               |             |             |             |              |           |             |              |       |        |              |      |      |           |      |       |      |       |      |       |             |  |
| 1.          | Find how much each of these children gained in height from his tenth to his fifteenth birthday.   | Alice  | 49      62       |                        |                       |               |             |             |             |              |           |             |              |       |        |              |      |      |           |      |       |      |       |      |       |             |  |
|             |   | Arthur   | 50      61½      |                        |                       |               |             |             |             |              |           |             |              |       |        |              |      |      |           |      |       |      |       |      |       |             |  |
| 2.          | What percent (of her height at the age of 10) did Alice gain?   | Bertha   | 50      63       |                        |                       |               |             |             |             |              |           |             |              |       |        |              |      |      |           |      |       |      |       |      |       |             |  |
|             |   | George   | 52      66¼      |                        |                       |               |             |             |             |              |           |             |              |       |        |              |      |      |           |      |       |      |       |      |       |             |  |
| 3.          | What percent of his height at the age of 10 did Arthur gain?  |  |                  |                        |                       |               |             |             |             |              |           |             |              |       |        |              |      |      |           |      |       |      |       |      |       |             |  |
| 4.          | How much more must George gain to be exactly 6 ft. tall?  |  |                  |                        |                       |               |             |             |             |              |           |             |              |       |        |              |      |      |           |      |       |      |       |      |       |             |  |
| 5.          | Bertha gained 40 lb. in all from her tenth birthday to her fifteenth birthday. Her mother says that Bertha made 70 percent of this gain during the 15 vacation months, and only 30 percent of it during the 45 school months. If that is correct, how many pounds did Bertha gain per month (a) In vacation time? (b) In school time? |  |                  |                        |                       |               |             |             |             |              |           |             |              |       |        |              |      |      |           |      |       |      |       |      |       |             |  |
| 6.          | Find how long it takes each of these trains to go (a) from Chicago to Marion; (b) from Chicago to Omaha.  | <table border="0"> <thead> <tr> <th></th> <th>Missouri River Express</th> <th>San Francisco Limited</th> <th>Local Express</th> </tr> </thead> <tbody> <tr> <td>Lv. Chicago</td> <td><b>6 05</b></td> <td><b>9 35</b></td> <td><b>10 00</b></td> </tr> <tr> <td>Dan. Jct.</td> <td><b>8 14</b></td> <td><b>11 32</b></td> <td>12 30</td> </tr> <tr> <td>Marion</td> <td><b>11 50</b></td> <td>3 10</td> <td>5 30</td> </tr> <tr> <td>Pickering</td> <td>1 30</td> <td>.....</td> <td>7 35</td> </tr> <tr> <td>Omaha</td> <td>7 19</td> <td>10 10</td> <td><b>3 25</b></td> </tr> </tbody> </table> |                  | Missouri River Express | San Francisco Limited | Local Express | Lv. Chicago | <b>6 05</b> | <b>9 35</b> | <b>10 00</b> | Dan. Jct. | <b>8 14</b> | <b>11 32</b> | 12 30 | Marion | <b>11 50</b> | 3 10 | 5 30 | Pickering | 1 30 | ..... | 7 35 | Omaha | 7 19 | 10 10 | <b>3 25</b> |  |
|             | Missouri River Express  | San Francisco Limited  | Local Express    |                        |                       |               |             |             |             |              |           |             |              |       |        |              |      |      |           |      |       |      |       |      |       |             |  |
| Lv. Chicago | <b>6 05</b>   | <b>9 35</b>  | <b>10 00</b>     |                        |                       |               |             |             |             |              |           |             |              |       |        |              |      |      |           |      |       |      |       |      |       |             |  |
| Dan. Jct.   | <b>8 14</b>   | <b>11 32</b>   | 12 30            |                        |                       |               |             |             |             |              |           |             |              |       |        |              |      |      |           |      |       |      |       |      |       |             |  |
| Marion      | <b>11 50</b>  | 3 10   | 5 30             |                        |                       |               |             |             |             |              |           |             |              |       |        |              |      |      |           |      |       |      |       |      |       |             |  |
| Pickering   | 1 30  | .....  | 7 35             |                        |                       |               |             |             |             |              |           |             |              |       |        |              |      |      |           |      |       |      |       |      |       |             |  |
| Omaha       | 7 19  | 10 10  | <b>3 25</b>      |                        |                       |               |             |             |             |              |           |             |              |       |        |              |      |      |           |      |       |      |       |      |       |             |  |
| 7.          | Which train takes about 40 percent longer than the San Francisco Limited?   |  |                  |                        |                       |               |             |             |             |              |           |             |              |       |        |              |      |      |           |      |       |      |       |      |       |             |  |
| 8.          | When will the Missouri River Express arrive at Omaha if it loses 1 hr. 16 min. and then makes up ¾ of the loss?   |  |                  |                        |                       |               |             |             |             |              |           |             |              |       |        |              |      |      |           |      |       |      |       |      |       |             |  |
| 9.          | When will the San Francisco Limited arrive at Omaha, if it loses 1 hr. 20 min. and then makes up 48 minutes of the lost time?   |  |                  |                        |                       |               |             |             |             |              |           |             |              |       |        |              |      |      |           |      |       |      |       |      |       |             |  |
| 10.         | When will the Local Express arrive at Omaha, if it loses 17 min. between Chicago and Dan. Jct., 31 min. between Dan. Jct. and Marion, and 1 hr. 8. min. between Marion and Omaha?   |  |                  |                        |                       |               |             |             |             |              |           |             |              |       |        |              |      |      |           |      |       |      |       |      |       |             |  |

Numbers in heavy type are P.M.  
Numbers in light type are A.M.



**87. Which Is Longer, Larger, Heavier?**

The boys were trying to decide which of these was the longest jump:

R. Locke, 14.75 ft.    D. Wade, 14 ft. 8 in.

V. Lavissee (a boy in France), 4.41 meters  
(1 meter = 39.37 in.).

S. Beach,  $3\frac{3}{4}$  yd.

1. Which was the longest?    2. The next longest?

Some girls were trying to decide which of these is the largest blanket:

$2\frac{1}{4}$  yd.  $\times$   $2\frac{1}{2}$  yd.    2 yd. 4 in.  $\times$  2 yd. 6 in.

2 meters long  $\times$  2 meters wide.    80 in.  $\times$  78 in.

3. Which is the largest?    4. The next largest?  
5. How did you find out?  
6. Which is larger, a box 4 ft. 2 in.  $\times$  3 ft. 6 in.  $\times$  1 ft. 4 in.  
or a box 4.1'  $\times$  3.7'  $\times$  1.3'? How much larger?  
7. Which is the heavier load, 1.36 ton or 2700 lb.? How  
much heavier?  
8. Which is the taller boy, John who is 4 ft.  $11\frac{1}{4}$  in. or Fred  
who is  $58\frac{3}{4}$  in.? How much taller?

**88.**

Find the missing numbers. Do as much of the work mentally as you can.

- |                                  |                               |
|----------------------------------|-------------------------------|
| a. 90 in. = ... ft. ... in.      | i. 1 hr. 8 min. = ... min.    |
| b. 76 in. = ... yd. ... in.      | j. 1 hr. 48 min. = ... min.   |
| c. $1\frac{1}{2}$ gal. = ... qt. | k. 30 days = ... wk. ... da.  |
| d. $1\frac{1}{4}$ gal. = ... pt. | l. 2 lb. 5 oz. = ... oz.      |
| e. 2.75 ft. = ... ft. ... in.    | m. 3.5 lb. = ... oz.          |
| f. $\frac{1}{2}$ mi. = ... yd.   | n. 2 ft. 6 in. + 20 in. = ... |
| g. 4 da. 2 hr. = ... hr.         | o. 1 ft. 4 in. + 20 in. = ... |
| h. 2 da. 8 hr. = ... hr.         | p. 1.75 lb. = ... oz.         |

You need not extend decimal numbers beyond the third decimal place on this page.

- Express each of these quantities as a decimal number of inches:  
 a. 1.4 ft.   b. .65 ft.   c. 1.71 ft.   d. .6 ft.   e. 1.1 yd.
- Express each of these quantities as a decimal number of feet:  
 a. 5 in.   b. 1 ft. 5 in.   c. 9 in.   d. 1 ft. 9 in.   e. 4.5 in.
- Express each of these weights as a decimal number of pounds.  
 a. 9 oz.   b. 4 lb. 9 oz.   c. 7 lb. 5 oz.   d. 14 oz.
- Express each of these as a decimal number of miles or tons or acres, as is required:  
 a. 584 yd.   b. 1725 ft.   c. 3 mi. 714 yd.   d. 6 mi. 740 ft.  
 e. 25,680 lb.   f. 3 tons 540 lb.   g. 1 ton 490 lb.  
 h. 18,725 lb.   i. 75 sq. rd.   j. 2 A. 24 sq. rd.  
 k. 256 sq. rd.   l. 3 A. 130 sq. rd.
- Find the total length of time each of these children spent on home work during the six days. Then find the average time spent per day for each child. Decide, before you begin, whether to express the total length in hours and minutes, or in minutes.

	Alice	George	Joe
Monday	1 hr. 5 min.	35 min.	55 min.
Tuesday	50 min.	25 min.	45 min.
Wednesday	1 hr.	1 hr. 10 min.	35 min.
Thursday	55 min.	45 min.	1 hr. 15 min.
Friday	45 min.	50 min.	20 min.
Saturday	25 min.	1 hr. 5 min.	1 hr. 45 min.
Total time for 6 da. ....	.....	.....	.....
Average time per day .....	.....	.....	.....

In multiplying to find area or volume or capacity, express all dimensions in the same unit of measure. Choose the unit of measure that will make the work accurate and easy (especially accurate.) Then express the result in the unit of measure asked for by the problem.

1. If the dimensions of a tank are given as 3 ft.  $\times$  4 ft. 4 in. by 18 in., which is better to use, feet ( $3 \times 1\frac{3}{4} \times \frac{3}{2}$ ) or inches ( $36 \times 52 \times 18$ )?

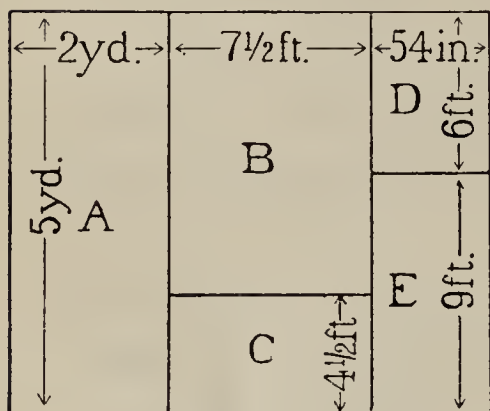

2. Find the area of each of the garden plots represented in this diagram. (You are left to choose whether to express the area as sq. rd., sq. yd., sq. ft., or sq. in., whichever you think best.)

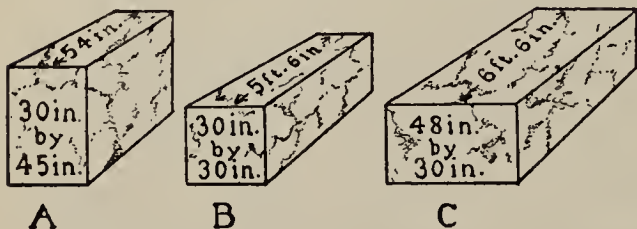

3. Find the volume of each of these blocks of marble. Express it in cubic feet.

4. Find the surface covered by each of the rugs described in the advertisement below. Express it in sq. yd. Then find the cost per sq. yd. for each rug.

### Special Sale

#### Domestic and Imported Rugs

Crex Grass		Ingrain Art Squares		Sherwood Axminsters	
36'' $\times$ 72''	\$ 1.20	7 $\frac{1}{2}$ ' $\times$ 9'	\$ 6.00	18'' $\times$ 36''	\$1.02
4 $\frac{1}{2}$ ' $\times$ 7 $\frac{1}{2}$ '	2.45	9' $\times$ 10 $\frac{1}{2}$ '	7.90	27'' $\times$ 60''	2.10
12' $\times$ 15'	13.75	10 $\frac{1}{2}$ ' $\times$ 12'	10.65	4 $\frac{1}{2}$ ' $\times$ 6 $\frac{1}{2}$ '	7.25

The children in the geography class had a contest in estimating the areas of different surfaces. Each child wrote his estimates for each of these maps, A, B, C, D, and E.

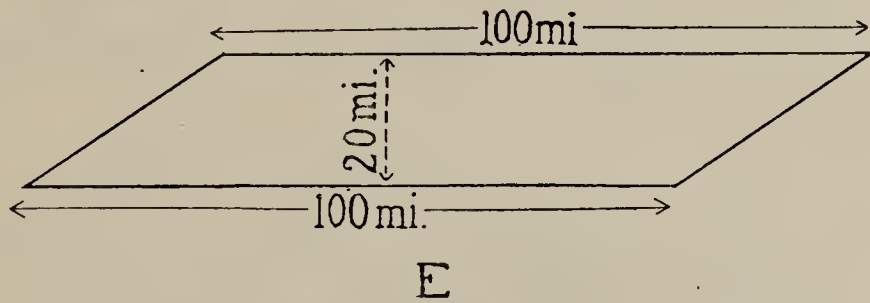
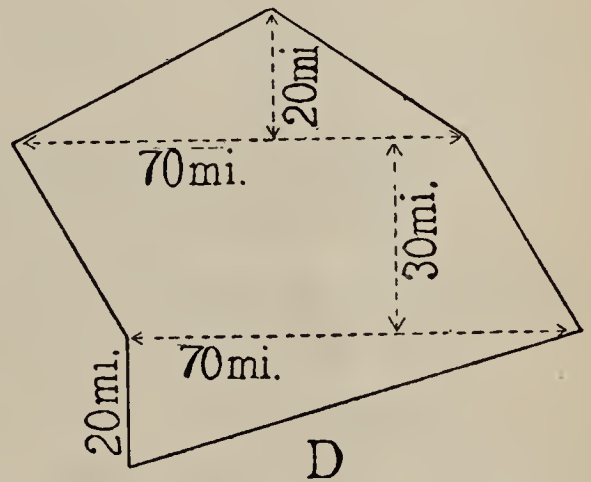
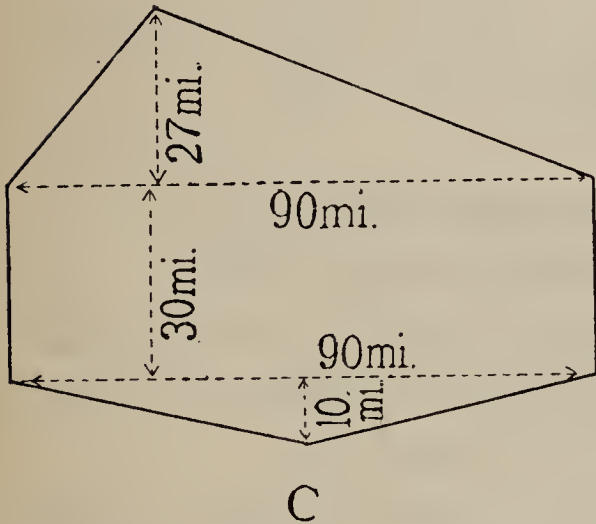
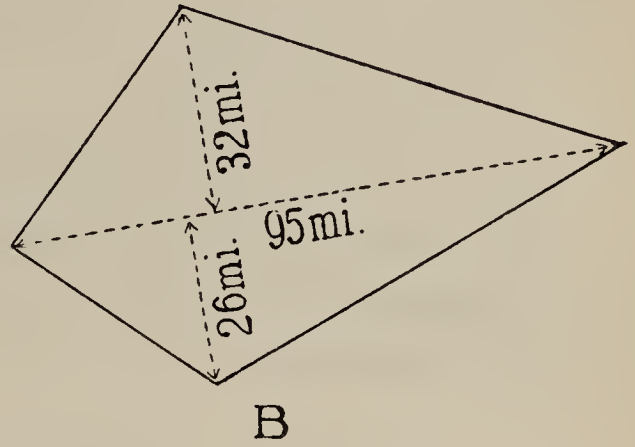
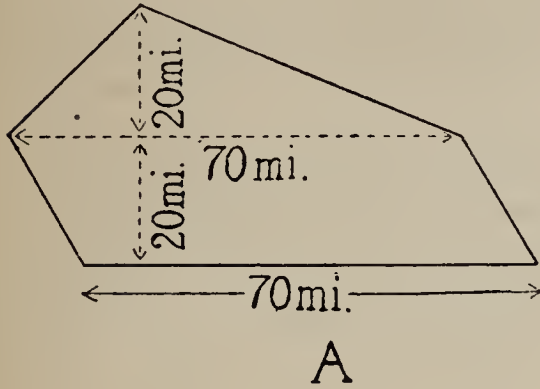

In the arithmetic class they learned how to find the exact areas. Then they compared their estimates with the exact areas to find who came nearest.

Write your estimates for A, B, C, D, and E. Then study the next 6 pages and learn how to find the exact areas.



222 92. Surfaces Bounded by Three Straight Lines

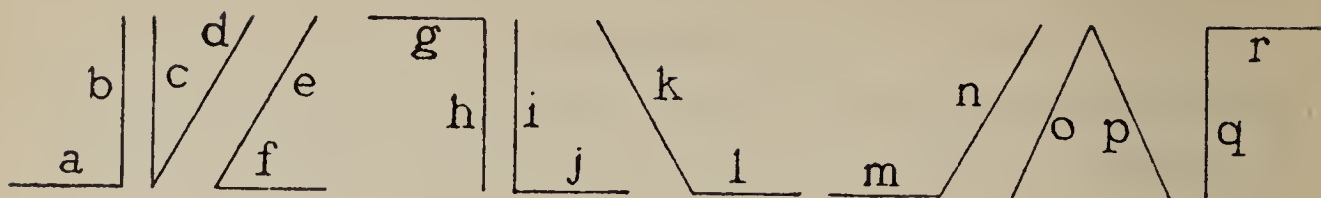

1. Which of these pairs of lines make right angles, like the corner of a book?
2. Which have a smaller opening than a right angle has?
3. Which have a larger opening than a right angle has?
4. In which of these pairs of lines are the two lines parallel like the two rails of a railroad track or the two edges of a foot rule.

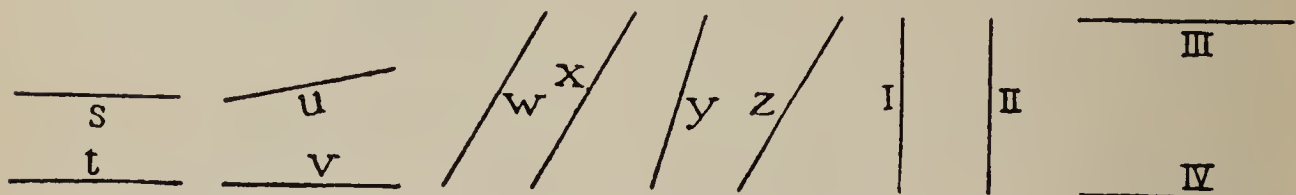

When one line makes a right angle with another line each line is perpendicular to the other.

5. Look at each of the pairs of lines above. Tell whether the two lines are perpendicular, parallel, or neither perpendicular nor parallel, but slanting.
6. Look about the room. Name 5 pairs of lines that are parallel. Name 5 pairs of lines that are perpendicular. Name 3 pairs of lines that are neither parallel nor perpendicular.

93.

1. Draw five triangles of different shapes. Mark the corners as shown in the picture.

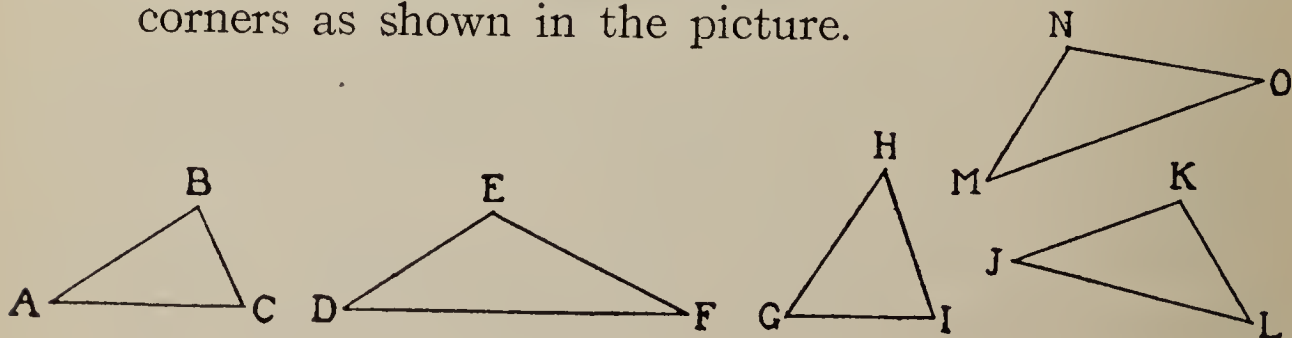

Take the sheet of paper with your five triangles, and a card which has right angles for its corners.

2. Draw a line from B to A C. Make it perpendicular to A C. Mark with an X the point where this perpendicular line cuts A C, as shown in the picture.

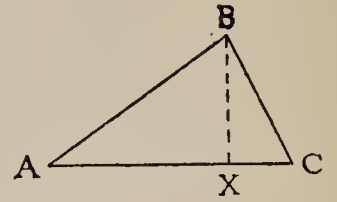

We call A C the base of the triangle A B C.

We call B X the height or altitude of the triangle A B C.

3. Draw a line from E to D F; make it perpendicular to D F. Mark with a Y the point where this perpendicular cuts D F.
4. Which line is the base of the triangle D E F?
5. Which line is the height or altitude of the triangle D E F?
6. Draw H Z to be the altitude of the triangle G H I. What is the base of the triangle G H I?
7. Draw K W to be the altitude of triangle J K L. What is the base of this triangle?

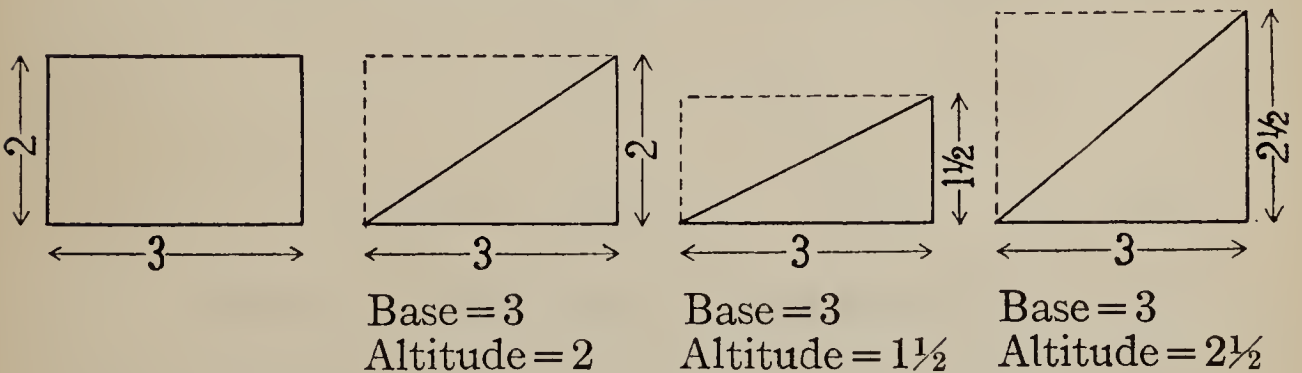

Examine this rectangle and the three triangles.

8. Which triangle's area =  $\frac{1}{2}$  of 6 (an area  $3 \times 2$ )?
9. Which triangle's area =  $\frac{1}{2}$  of  $4\frac{1}{2}$  (an area  $3 \times 1\frac{1}{2}$ )?
10. Which triangle's area =  $\frac{1}{2}$  of  $7\frac{1}{2}$  (an area  $3 \times 2\frac{1}{2}$ )?
11. Show that your answers are right by cutting out paper rectangles  $3 \times 2$  inches,  $3 \times 1\frac{1}{2}$  in. and  $3 \times 2\frac{1}{2}$  in. and folding each along its diagonal into two halves.

A level or plane surface bounded by four straight lines is called a **QUADRILATERAL**.

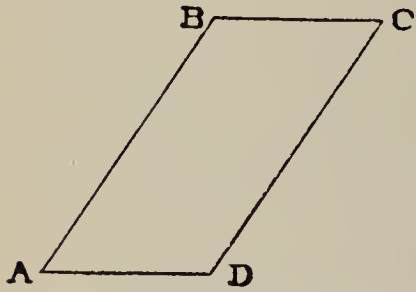

1. Using a ruler and a postal card (or other card with two edges that are everywhere equally far apart), draw a quadrilateral like  $A B C D$ , with its opposite sides parallel.

The quadrilateral inclosed by  $A B$ ,  $B C$ ,  $C D$ , and  $D A$  is called a **parallelogram** because in each pair of opposite sides the lines are parallel.



A rectangle is a parallelogram with all its angles right angles.

A quadrilateral which has only one pair of sides parallel is called a **trapezoid**.



2. Examine each of these quadrilaterals. Tell whether it is a parallelogram or a trapezoid, or neither.

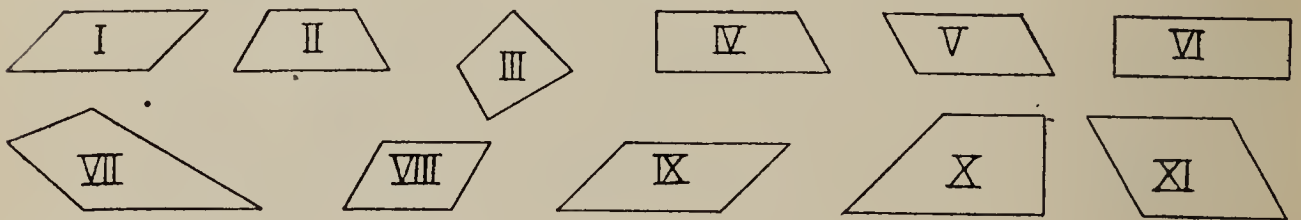

3. Draw three parallelograms and three trapezoids. Draw in each a perpendicular line from one of a pair of parallel sides to the other. Mark one of the pairs of parallel sides *base*. Mark the perpendicular *h.* or *alt.* (*height* or *altitude*).

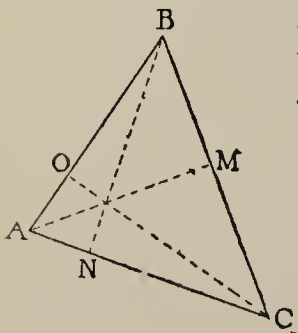

4. Which line shows the height or altitude of this triangle when  $A B$  is taken as the base? When  $B C$  is taken as the base? When  $A C$  is taken as the base?

5. If one side of a triangle is perpendicular to the base do you need to draw a new line to show the height or altitude?
6. Measure the height or altitude of each of these triangles.

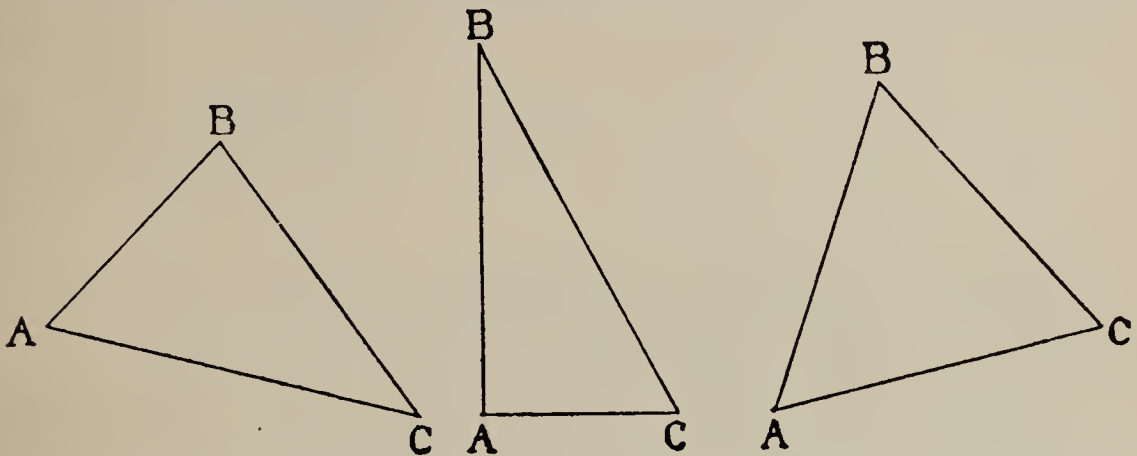

7. Measure the altitude of each of these parallelograms.

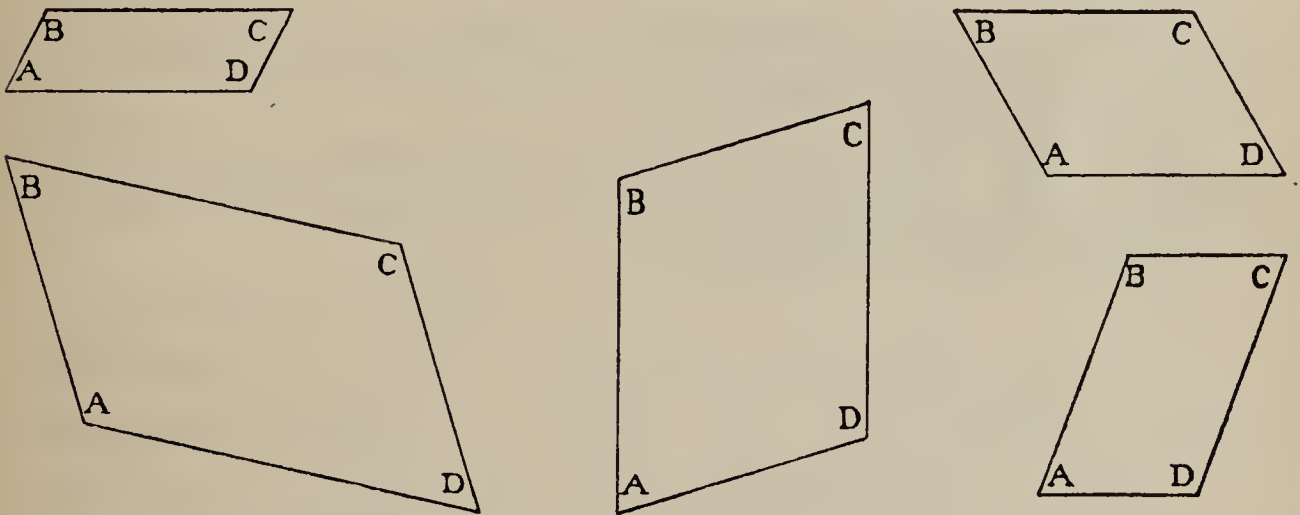

### 95. How to Find the Area of a Parallelogram

1. Using paper ruled in inch squares, cut out a rectangle like  $A B C D$ , with base 6 in. and height 3 inches. Cut out a parallelogram like  $L M N O$  with base 6 in. and height 3 in., the same as in the rectangle. What is the area of the rectangle?

2. See how the parallelogram compares in size with

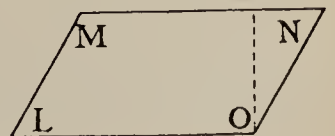
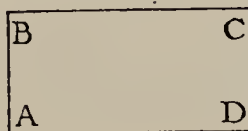



the rectangle by cutting off one end of the parallelogram, as shown by the dotted line, and placing the two pieces to cover the rectangle.

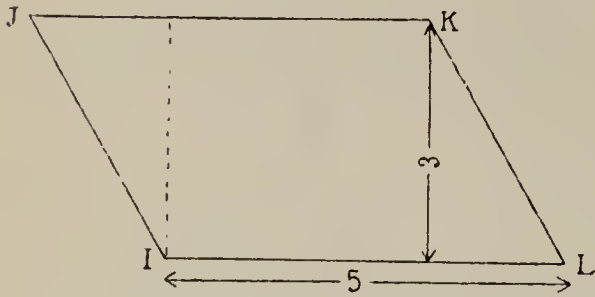

3. Make a rectangle with a base of 5 in. and height or altitude 3 in. Make a parallelogram like I J K L, of the same base

and altitude as the rectangle, slanting like the diagram. Cut and compare as you did before.

4. Compare other sizes of rectangles with other parallelograms of equal base and altitude until you are sure that —

The area of any parallelogram = the area of a rectangle of the same base and altitude.

The area of any parallelogram = the product of its base and altitude. Base and altitude must be expressed in the same unit of measure before multiplying.

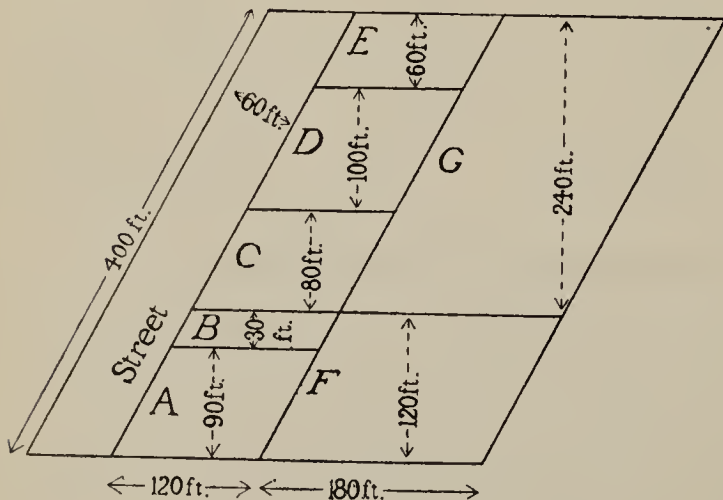

5. Tell the area of each of the lots represented on this map. (Each lot is a parallelogram.)
6. Tell the area of the street represented on this map.
7. Tell the areas of each of these parallelograms:

- |  |                             |
|--|-----------------------------|
| a. Base 50 mi., altitude 20 mi.            | b. Base 12 mi., alt. 9 mi.  |
| c. Base 8 mi., altitude $2\frac{1}{2}$ mi. | d. Base 2.4 mi., alt. 2 mi. |
| e. Base 7.3 mi., alt. 2.25 mi.             | f. Base 0.8 mi., alt. 4 mi. |

1. Using paper ruled in squares, cut out a triangle like this with 4 in. as base, and 2 in. as altitude. Make another just like it. Cut one

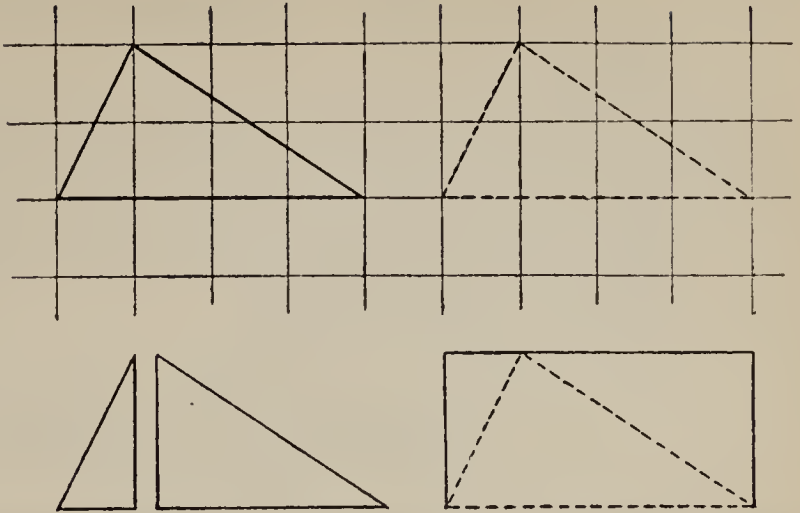

of them into two triangles as shown. Put the two pieces and the whole triangle together to make a rectangle with 4 in. as base and 2 in. as altitude.

2. Do the same with other triangles until you are sure that—

The area of any triangle =  $\frac{1}{2}$  the product of its base and altitude.

3. Find the number of square feet in each of these sails.

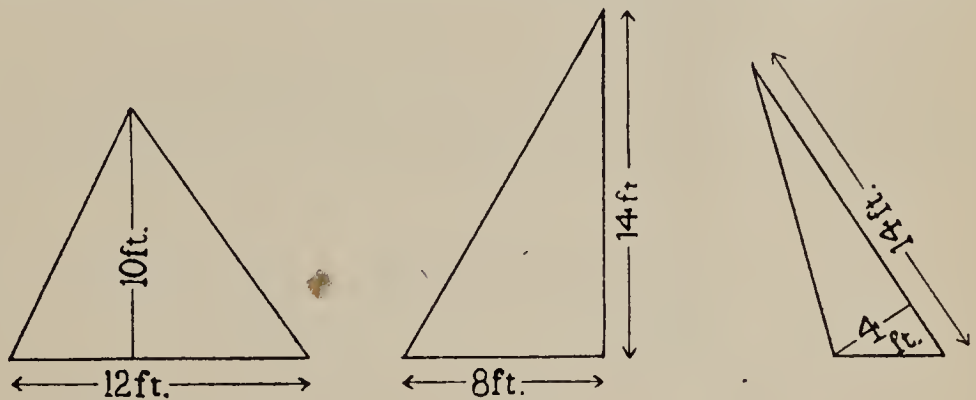

4. Find the area of each of these fields. All dimensions are rods. The two quadrilaterals are parallelograms. In any parallelogram, opposite sides are equal.

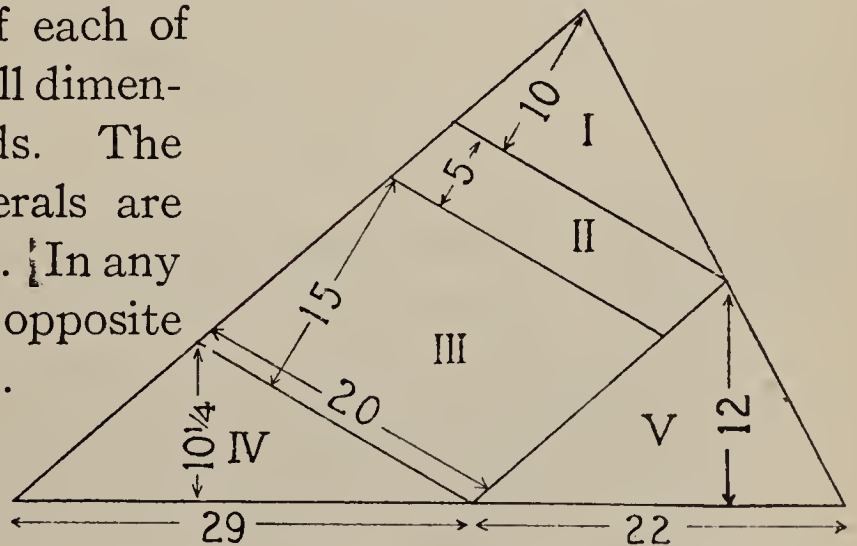

5. Turn to page 221. Find the true area of A, B, C, D, and E.
6. How near was your estimate in each case?
7. Calling the difference between your estimate and the real area your error, what was your average error for A, B, C, D, and E?

**97. How to Find the Area of Any Surface  
Bounded by Straight Lines**

To find the area of a field that is not a simple rectangle, parallelogram, or triangle, a farmer cuts it into parallelograms and triangles and finds the area of each of these from its base and altitude.

1. Make a tracing of this map with thin paper. Divide it into triangles by a line.  $\frac{1}{8}$  inch stands for 1 rod.



2. Measure the base and altitude of each triangle to the nearest eighth of an inch and find the area of each triangle, but before computing the areas in square rods make sure that your measurements of base and altitude are correct by comparing them with those of other pupils.

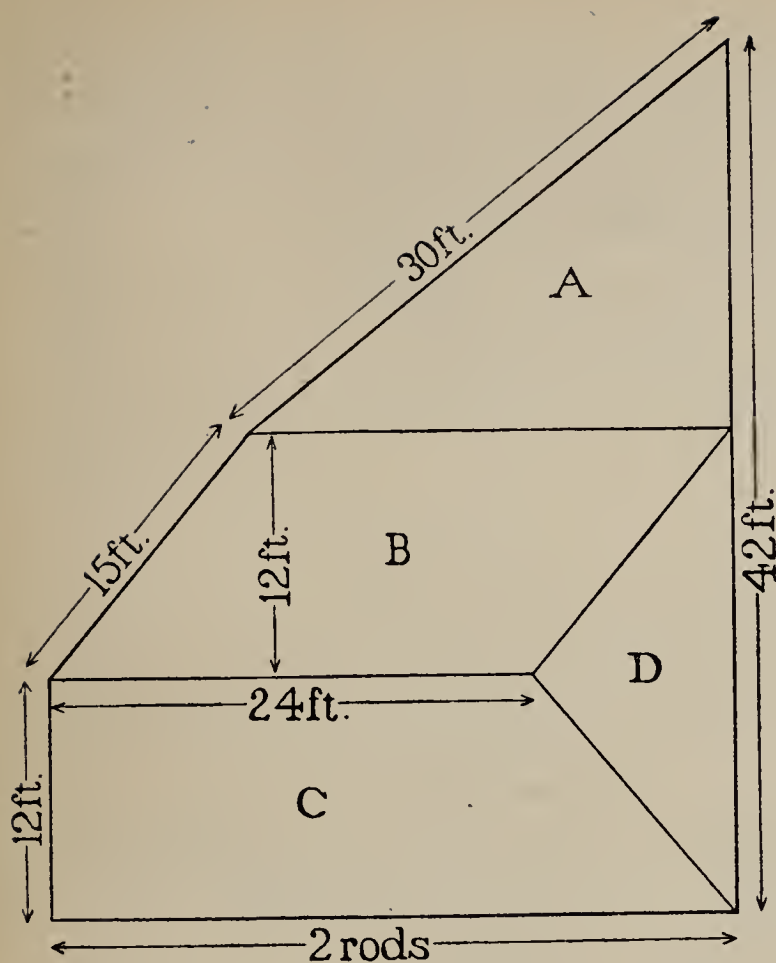

3. Find the area represented by the whole map on p. 228, counting each  $\frac{1}{8}$  inch as 1 rod.
4. What does the *perimeter* of a yard or lot mean?
5. Find the perimeter of each of these chicken yards and the cost of wire fencing to go around it at 4¢ per foot of distance.
6. Find the area of each in sq. ft.

Remember that in finding the area of any surface, both dimensions must be expressed in the same unit of measure.

7. Write your results neatly in a table like this:

Perimeter in Ft.	Cost of Fence	Area in Sq. Ft.
A		
B		
C		
D		

8. Allowing 6 sq. ft. to a chicken, how many chickens may be put in yard A? In yard B?
9. Find the area of:
  - a. A parallelogram of base  $2\frac{5}{8}$  in. and altitude  $1\frac{3}{5}$  in.
  - b. A triangle of base  $8\frac{3}{4}$  in. and altitude 16 in.
  - c. A square 4.06 in. on a side.



## 98. How to Find the Area of a Trapezoid

1. Study these diagrams and try to find a way to learn the area of a trapezoid, when the length of each of its two parallel sides and its altitude are known.

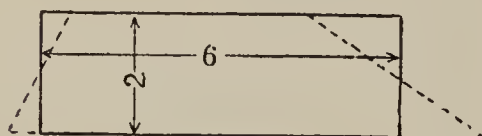
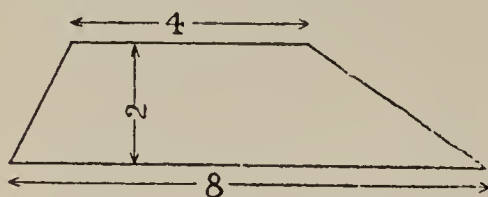

Compare the altitudes of the trapezoid and the rectangle.

Compare the base of the rectangle with the average length of the two parallel sides of the trapezoid.

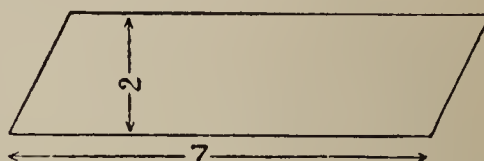
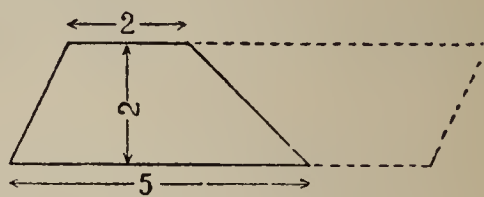

Compare the surface made by doubling the trapezoid with a parallelogram which has the same altitude as the trapezoid, and a base equal in length to the sum of the two parallel sides of the trapezoid.

2. Which of these gives the correct area for a trapezoid?

$$\text{Area} = \frac{1}{2} (\text{sum of two parallel sides}) \times \text{altitude.}$$

$$\text{Area} = \text{base} \times \text{altitude.}$$

$$\text{Area} = (\text{sum of 2 parallel sides}) \times \text{altitude.}$$

$$\text{Area} = \frac{1}{2} (\text{base} \times \text{altitude}).$$

3. Can you prove that your answer to Ex. 2 is right?

## 99. How Many Times as

{ Tall,  
Long,  
Large,  
Heavy, etc.

1. Tell the missing numbers:

A.

$$84 = \dots \times 21$$

$$44 = \dots \times 4$$

$$1.6 = \dots \times 2$$

$$1.6 = \dots \times 20$$

B.

$$\frac{1}{2} \text{ in.} = \dots \times \frac{1}{4} \text{ in.}$$

$$\frac{3}{4} \text{ lb.} = \dots \times \frac{1}{4} \text{ lb.}$$

$$1 \text{ hr.} = \dots \times \frac{1}{4} \text{ hr.}$$

$$\$1.25 = \dots \times 25\text{¢}$$

C.

$$6 = \dots \text{ of } 24$$

$$6 = \dots \text{ of } 18$$

$$6 = \dots \text{ of } 48$$

$$6 = \dots \text{ of } 9$$

## 2. Examine this:

Will is 55 in. tall. Nell is 44 in. tall.

$$\begin{array}{r} 1.25 \\ 44 \overline{)55.0} \\ \underline{44} \\ 110 \\ \underline{88} \\ 220 \\ \underline{220} \end{array}$$

We say:

*Will is 1.25 times as tall as Nell;*

*or, Will is 125 percent as tall as Nell;*

*or, Will is  $1\frac{1}{4}$  times as tall as Nell;*

*or, Will's height is 1.25 times Nell's height, etc.*

$$\begin{array}{r} .8 \\ 55 \overline{)44.0} \\ \underline{44} \ 0 \end{array}$$

We say:

*Nell is .8 times as tall as Will;*

*or, Nell is 80 percent as tall as Will;*

*or, Nell is  $\frac{4}{5}$  as tall as Will;*

*or, Nell's height is .8 times Will's height, etc.*

## 3. Divide and supply the missing numbers and words.

Use a decimal number or a common fraction or mixed number or a percent, whichever is easiest for you. After you have obtained the results, copy them in order on a small slip of paper.

a. 224 ft. is . . . as long as 160 ft.

b. 441 lb. is . . . as heavy as 196 lb.

c. \$1.25 is . . . as much as \$7.50.

d. 34¢ per lb. is . . . as expensive as 50¢ per lb. for the same thing.

e. 65.6 min. is . . . as long as 80 min.

f. 11.5 A. is . . . as large as 15 A.

g. 35 mi. is . . . as wide as 105 mi.

## 4. Place the slip of paper containing your results beside Ex. 3, and read each line, expressing your result as a decimal number. Then read each line, expressing your result as a common fraction or mixed number. Then read each line, expressing your result as a percent.

To find how many times a quantity contains another quantity, express both in the same unit of measure before dividing. Choose the unit of measure that will make the work easy and accurate, especially accurate.

*To solve —*

$2\text{ ft. }4\text{ in.} = \dots \times 4\text{ in.}$ , express it as  $28\text{ in.} = \dots \times 4\text{ in.}$

$102\text{ in.} = \dots \times 1\text{ ft. }5\text{ in.}$ , express it as  $102\text{ in.} = \dots \times 17\text{ in.}$

$5\text{ bu.} = \dots \times 4\text{ qt.}$ , express it as  $160\text{ qt.} = \dots \times 4\text{ qt.}$

Find the missing numbers:

1. A weight of 3 lb. 2 oz. is... times as heavy as 5 oz.
2. A weight of 2 tons is... times as heavy as 400 lb.
3. 10 ft. 8 in. of wire will make... pieces each 8 in. long.
4. A visit of 5 wk. 3 da. is... times as long as 2 wk. 5 da.
5. 3 A. will make... plots of 60 sq. rd. each.
6. It will take... mats each  $3 \times 5$  ft. to cover 10 sq. yd. of floor space.
7. 6 dollars = ... 25-cent pieces.
8. 4 gal. 3 pt. of cream will fill...  $\frac{1}{2}$ -pint bottles.

### 101. Problems

*(Mental work.)*

1. At 2 oranges for 5¢, what is the cost (a) for 4? (b) For 12?
2. At 3 apples for 10¢, what is the cost (a) for a dozen? (b) For  $2\frac{1}{2}$  dozen?
3. At 7 grape-fruit for a dollar, what is the cost of 21?
4. At the rate of 10 problems in 40 seconds, (a) how long will it take Alice to solve 30? (b) How many can she solve in 3 min.?
5. If 6 melons cost 75¢, what is the cost at the same rate (a) of 18 melons? (b) Of 4 melons? (c) Of 8 melons?
6. If a man buys 9 melons, when you are selling them at 3 for 25¢, what will you charge him?

7. A grocer sells sugar at 4 lb. for 25¢, 17 lb. for a dollar. How much more sugar does he give for a dollar when you spend the whole dollar at one time?
8. He sells coffee at 28¢ per lb., 4 lb. for \$1.00. How much do you save on each pound by buying 4 lb. at one time instead of buying the same amount a pound at a time?

(With pencil.)

9. He gives 5% reduction on each cash purchase amounting to \$5 or over. What do you save on a purchase amounting to \$5.80 by buying all at once instead of \$2.80 worth one day and \$3.00 worth another day?
10. Suppose that 65 cents worth of the goods spoiled if you bought \$5.80 worth at one time, and that none spoiled if you bought them on four separate days, paying regular prices. How much would you lose by buying them at one time instead of separately?
11. Mrs. A., Mrs. B., and Mrs. C. share in buying 3 dozen cans of peaches, at \$2.65 per dozen. It cost 45 cents for express. Mrs. A. takes 15 cans, Mrs. B. takes 12 cans, and Mrs. C. takes 9 cans. How much should each of the ladies pay?

### 102. Making Mixtures of Seeds

1. A good mixture of grass seed for meadows is 2 lb. timothy, 2 lb. redtop, and 1 lb. red clover. We call this a mixture in the proportions 2, 2, 1 by weight. What percent of the mixture is timothy? What percent is redtop? What percent is clover?
2. How many pounds of each sort of seed will there be  
 (a) In 10 lb. of the mixture? (b) In 20 lb.? (c) In 50 lb.? (d) In 15 lb.? (e) In 22½ lb.? (f) In 100 lb.?



3. If a farmer sows 32 pounds of the mixture per acre, how much will be needed (a) For  $1\frac{1}{2}$  acres? (b) For  $3\frac{1}{4}$  acres? (c) For  $2\frac{3}{4}$  acres?
4. Mr. Ames prefers a mixture of timothy, redtop, and red clover in the proportions of 3, 2, 1 by weight. How many pounds of each does he take—(a) To make 12 pounds in all? (b) To make 36 lb. in all? (c) To make 18 lb.? (d) To make 100 lb.? (e) What fraction of a pound of each kind of seed is there in one pound of 3, 2, 1 mixture?
5. Arrange these descriptions of mixtures in groups of three, all three of which describe just the same sort of mixture.
  - a. 2 units of A, 2 units of B, and 1 unit of C.
  - b. 3 units of A, 2 units of B, and 1 unit of C.
  - c. 2 units of A, 1 unit of B, and 1 unit of C.
  - d. 5 units of A, 3 units of B, and 2 units of C.
  - e. 50% of A, 25% of B, and 25% of C.
  - f. 40% of A, 40% of B, and 20% of C.
  - g. 50% of A, 30% of B, and 20% of C.
  - h. 50% of A,  $33\frac{1}{3}\%$  of B,  $16\frac{2}{3}\%$  of C.
  - i.  $\frac{5}{10}$ ,  $\frac{3}{10}$ , and  $\frac{2}{10}$  for A, B, and C, respectively.
  - j.  $\frac{1}{2}$ ,  $\frac{1}{4}$ , and  $\frac{1}{4}$  for A, B, and C, respectively.
  - k.  $\frac{1}{2}$ ,  $\frac{1}{3}$ , and  $\frac{1}{6}$  for A, B, and C, respectively.
  - l.  $\frac{2}{5}$ ,  $\frac{2}{5}$ , and  $\frac{1}{5}$  for A, B, and C, respectively.
6. If 10 lb. of seed cost \$3 (a) What do 30 lb. cost? (b) What do 5 lb. cost? (c) What do 25 lb. cost?
7. If 2 pounds out of 10 lb. are weed seeds, how many pounds of weed seeds will you find (a) In 30 lb.? (b) In 5 lb.? (c) What fraction of a pound will be weed seeds?

1. Hold one end of a string which has a weight at the other end. The line the string makes when it is not swinging is a vertical line. A line drawn parallel to the surface of a pond is a horizontal line. Show five lines in your schoolroom that are horizontal and five that are vertical.
2. This is a plan showing the grade of a hill. The lower line in the picture represents a horizontal line. The short lines perpendicular to it represent vertical lines. Each  $\frac{1}{4}$ -inch represents 10 ft.
3. How long is the vertical line at 40? At 80? At 120? At 160?

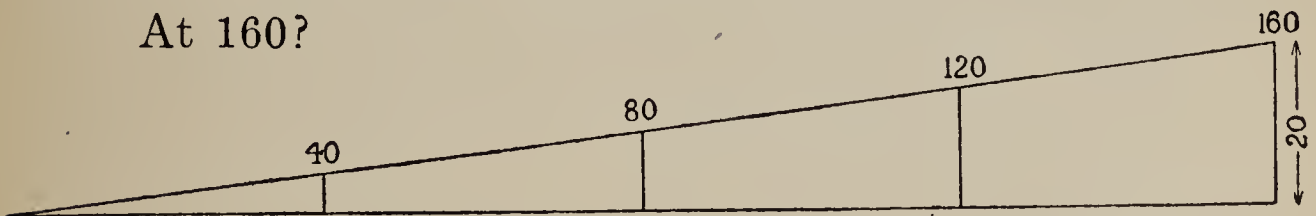

4. How many feet does the road rise in the first 40 ft. of its length?
5. How many feet does it rise in the whole 160 ft.?
6. What percent of its length does it rise?
7. How many feet of length are there for each foot of rise?  
Let  $\frac{1}{8}$  inch represent 1 ft.
8. Draw a plan of a road 40 ft. long that rises 1 ft. in 10.
9. Draw a plan of a road 40 ft. long that rises 1 ft. in 20.
10. Draw a plan of a road 40 ft. long that rises 1 ft. in 5.
11. How many feet will a road with an average rise or grade of 1 ft. in 40 (or  $2\frac{1}{2}\%$ ) rise in a mile of length?
12. How long must a road be to rise 50 ft., if it rises 1 ft. in 25?
13. How much must a road rise in each 100 ft. of length if it rises 60 ft. in 2000 ft. of length?
14. How much will a road rise in a mile if it is built with an average rise of  $2\frac{1}{2}$  ft. per hundred ft. of length?

Each pupil writes on the blackboard two problems about earning, spending, and saving. One problem is hard, the other is easy. The pupils solve either one or both as they choose. If you think you can solve the hard one, try to do so. If you think it is too hard for you, solve the easy one. If you have time, solve them both. Practice with these problems.

#### Easy Problems

1. Mary said, "I will spend half of all that I earn and put the rest in the bank." She earned \$5.18. How much should she put in the bank?
2. Joe said, "I will spend \$2.00 for tools and \$1.50 for other things. I will put the rest of what I earn in the bank." He earned \$7.95. How much should he put in the bank?
3. Henry said, "I will spend 15¢ per week during the 12 weeks. The rest of what I earn I will put in the bank." He earned \$6.18. How much should Henry put in the bank?

#### Harder Problems

How much should each of these children put in the bank?

4. Alice said, "I will put in the bank  $\frac{1}{3}$  of the first 3 dollars I earn,  $\frac{1}{2}$  of the second \$3 I earn, and  $\frac{3}{4}$  of any other money I earn." She earned \$10.80.
5. Frank said, "I will spend 25% of the first \$5 I earn, 40% of the second \$5 I earn, and 50% of any more money that I earn. The rest I will put in the bank." He earned \$11.74.
6. Nathan said, "I will divide my earnings into three equal parts. Of the first third I will save half; of the second third I will save three quarters; of the last third I will save all. What I save I will put into the bank." He earned \$12.78.



Suppose that you are a clerk selling butter and cheese at these prices. Find the cost of each purchase.

Butter		Cheese	
<i>Standard Creamery</i>	24¢ per pound	<i>Cottage</i>	16¢ per pound
<i>Oak Farm</i>	30¢ “ “	<i>Full Cream</i>	22¢ “ “
<i>Cedar Farm Special</i>	34¢ “ “	<i>Old English</i>	32¢ “ “
<i>XX Unsalted</i>	45¢ “ “	<i>Swiss</i>	38¢ “ “

- $\frac{3}{4}$  lb. Oak Farm butter.
- $1\frac{3}{4}$  lb. Oak Farm butter.
- $\frac{3}{8}$  lb. Cottage cheese.
- $\frac{3}{16}$  lb. Old English cheese.
- $\frac{5}{16}$  lb. Old English cheese.
- $\frac{1}{2}$  lb. Swiss cheese.
- $\frac{1}{4}$  lb. Swiss cheese.
- $\frac{5}{16}$  lb. Swiss cheese.
- $\frac{7}{16}$  lb. Oak Farm butter.
- $1\frac{3}{16}$  lb. Oak Farm butter.
- $1\frac{3}{16}$  lb. Swiss cheese.
- $2\frac{1}{4}$  lb. Cedar Farm butter.
- $\frac{9}{16}$  lb. Unsalted butter.
- $\frac{9}{16}$  lb. Old English cheese.
- 4 lb. Standard creamery.
- $1\frac{1}{16}$  lb. Swiss cheese.
- $\frac{11}{16}$  lb. Swiss cheese.
- $\frac{9}{16}$  lb. Oak Farm butter.
- $1\frac{1}{8}$  lb. Full cream cheese.
- $3\frac{1}{2}$  lb. Full cream cheese.
- $1\frac{3}{16}$  lb. Cottage cheese.
- $2\frac{3}{4}$  lb. Cedar Farm butter.
- 6 lb. Standard creamery.
- $\frac{11}{16}$  lb. Old English cheese.
- $1\frac{5}{16}$  lb. Old English cheese.
- $2\frac{1}{4}$  lb. Cedar Farm butter.
- $\frac{7}{8}$  lb. Full cream cheese.
- $1\frac{3}{16}$  lb. Old English.
- $\frac{3}{4}$  lb. Full cream cheese.
- $1\frac{5}{16}$  lb. Swiss cheese.
- $3\frac{7}{16}$  lb. Old English cheese.
- $1\frac{1}{8}$  lb. Standard creamery.
- $2\frac{5}{16}$  lb. Oak Farm butter.
- $1\frac{3}{4}$  lb. Cedar Farm butter.
- $2\frac{5}{16}$  lb. Old English cheese.
- $\frac{9}{16}$  lb. Unsalted butter.
- 23 oz. Cottage cheese.
- 1 lb. 7 oz. Oak Farm butter.
- 2 lb. 3 oz. Old English.
- 1 lb. 5 oz. Swiss cheese.
- 1 lb. 5 oz. Old English.
- 1 lb. 1 oz. Swiss cheese.
- 9 oz. Swiss cheese.
- 1 lb. 5 oz. Oak Farm.
- 5 oz. Unsalted butter.
- 11 oz. Swiss cheese.
- 20 oz. Cottage cheese.
- 1 lb. 6 oz. Oak Farm.
- 10 oz. Unsalted butter.
- 2 lb. 4 oz. Old English.



Play this game:

Four children stand at the front of the room. One is the Giver. The others are the Sharers. A, B, and C stand for the Sharers' names. The Giver says, "I have \$40" [or \$10 or 75¢ or any amount that he thinks of]. "It is shared by A, B, and C in these proportions: 5 parts to A, 3 parts to B, and 2 parts to C, or 50%, 30%, and 20%."

A says, "I receive . . . of the \$40" [or whatever the amount is], "or . . ."

B says, "I receive . . . of the \$40" [or whatever the amount is], "or . . ."

C says, "I receive . . . of the \$40" [or whatever the amount is], "or . . ."

The other pupils in the class find each number, using pencil and paper if necessary. They correct any mistakes the four children make.

Sometimes the Giver says: "I have \$50" [or \$10 or 25¢ or any amount he thinks of]. "I give A \$20" [or any amount that is reasonable]; I give B \$18" [or any amount that is sensible]; "I give C the rest of the money."

A says, "I receive . . . of it," telling what fraction or percent his share is.

B says, "I receive . . . of it," telling what fraction or percent his share is.

C says, "I receive . . . of it," telling what fraction or percent his share is.

The other pupils in the class find each number, using pencil and paper if necessary. They correct any mistakes that the four children make and find in what proportions or percents the money was shared. Sometimes have 2 sharers instead of 3; sometimes have 4 sharers.

I. Solve these problems:

- a. 24 rows of peas are to be hoed. A hoes 15, B hoes 6, C hoes 3. What fraction or percent of the 24 rows does each hoe? In what proportions was the work shared?
- b. 60 lb. of camping outfit are to be carried. A, B, and C share the load in these proportions: 2 parts to A, 1 part to B, and 1 part to C. How many pounds does each carry?

II. Make up problems about sharing the hours of watching on a ship, the distance a canoe is to be paddled, the distance a pony is to be ridden, and the cost of a victrola.

III. Practice with these so that you will make no mistakes in finding your share when you play the game. Find how much each person receives when —

1. \$25 is distributed to A, B, and C in these proportions: 2, 2, and 1.
2. 40¢ is distributed to A and B in these proportions: 3 and 2.
3. \$1.08 is distributed to A, B, and C in equal proportions.
4. \$4.00 is distributed to A, B, and C in these proportions: 4, 3, and 1.
5. \$10.00 is distributed to A, B, C, and D in these proportions: 3, 2, 2, and 1.
6. \$5.00 is distributed to A, B, and C in these proportions: 5, 1, and 4.
7. 15¢ is distributed to A and B in these proportions: 2 and 1.
8. \$3.00 is distributed to A, B, C, and D in equal proportions.

The same quantity may be expressed in different ways.

*For example, these all mean the same quantity:*

3 ft. 9 in.  $3\frac{3}{4}$  ft. 3.75 ft.  $1\frac{1}{4}$  yd. 1.25 yd. 1 yd. 9 in.

- Express each of these quantities in three or more different ways:
  - 5 ft. 6 in.
  - $\frac{1}{8}$  mile.
  - 1 hr. 12 min.
  - 1.375 bu.
  - 1 bu. 14 qt.
  - 1.625 lb.
  - 1 sq. mi. 80 A
  - 1 yd. 1 ft. 4 in.
- Multiply each of the quantities of Ex. 1 by 8. Express the results as decimal numbers (of ft., mi., hr., bu., lb., or sq. mi.).
- Divide each of the quantities of Ex. 1 by 2. Express the results as decimal numbers.

When there are several ways of expressing a quantity, choose the one that is most useful for your purpose.

The same fact about a number may be expressed in different ways.

*For example, these all mean the same fact:*

$\frac{1}{8} \times$        $.125 \times$        $12\frac{1}{2}\%$  of       $\frac{1}{8}$  of

- Express each of these in three other ways:
  - $\frac{1}{6}$  of
  - 25% of
  - $.33\frac{1}{3} \times$
  - $\frac{3}{4} \times$
  - $\frac{1}{10} \times$
  - 20% of
  - 50% of
  - $\frac{2}{3}$  of
  - $.375 \times$

When there are several ways of expressing a fact, choose the one that is most useful for your purpose.

The same operation may be indicated in different ways.

*For example  $7\frac{1}{2} \times 12$ ,  $12 \overline{)72}$ , and  $72 \div 12$  all mean the same operation.*

- Express each of these in the form of a fraction and cancel:
 

$12 \overline{)138}$        $16 \overline{)152}$        $48 \overline{)1736}$
- Check your results for Ex. 5 by dividing in the ordinary way.

109. Adding and Subtracting Unlike Fractions with Unfamiliar Denominators\* 241

If you ever have to add or subtract numbers like  $4\frac{7}{25}$ ,  $3\frac{11}{42}$ , and  $5\frac{8}{39}$ , or  $2\frac{2}{7}$ ,  $3\frac{1}{9}$ , and  $1\frac{5}{11}$ , first express them as decimal numbers to the third decimal place.

Thus  $4\frac{7}{25} = 4.280$

$$25 \overline{)7.00} \begin{array}{r} .28 \\ \underline{50} \\ 00 \end{array}$$

$3\frac{11}{42} = 3.262$

$$42 \overline{)11.000} \begin{array}{r} .262 \\ \underline{84} \\ 260 \\ \underline{252} \\ 80 \end{array}$$

$5\frac{8}{39} = 5.205$

$$39 \overline{)8.000} \begin{array}{r} .205 \\ \underline{78} \\ 200 \end{array}$$

$$\begin{array}{r} 4.280 \\ 3.262 \\ 5.205 \\ \hline \end{array}$$

12.747 is the sum.

- Express each of these fractions or mixed numbers as a decimal to the third decimal place. Write the numbers clearly.

- a.  $\frac{2}{7}$     b.  $\frac{4}{9}$     c.  $4\frac{8}{11}$     d.  $2\frac{1}{13}$     e.  $\frac{7}{13}$     f.  $\frac{4}{15}$     g.  $3\frac{5}{18}$   
 h.  $1\frac{7}{17}$     i.  $\frac{12}{19}$     j.  $\frac{5}{29}$     k.  $\frac{8}{35}$     l.  $\frac{17}{25}$     m.  $24\frac{2}{9}$   
 n.  $10\frac{65}{144}$     o.  $\frac{25}{63}$     p.  $10\frac{13}{210}$

Using the decimal numbers of your results —

- Add  $a$ ,  $b$ , and  $c$ .
- Subtract  $h$  from  $g$ .
- Add  $d$ ,  $e$ , and  $f$ .
- Subtract  $j$  from  $i$ .

\*TO THE TEACHER.— This section may well be omitted by all save the most gifted pupils, since fractions other than those already fully treated in this book will have to be added or subtracted only in rare and specialized work in technology or cost-accounting. (They will then be treated as here, the calculations being made with the appropriate tables and machines.)



“Multiply 30 by 24 and divide the product by the product of 15 and 16” means the same as “ $(30 \times 24) \div (15 \times 16)$ .”

So does  $\frac{30 \times 24}{15 \times 16}$

1. Find the result by canceling. Check the result by multiplying and dividing in the ordinary way.

When the product of two numbers is to be divided by a number or by the product of two numbers, it is often useful to cancel before multiplying and dividing in the regular way.

In solving problems 2, 3, and 4 write the numbers in the form  $\frac{\dots \times \dots}{\dots \times \dots}$  or  $\frac{\dots \times \dots \times \dots}{\dots \times \dots}$  and cancel when you can, before multiplying and dividing in the regular way.

2. How many times as much food is required to feed 160 men for 27 days as is needed for 75 men for 30 days?

$\frac{160 \times 27}{75 \times 30}$  is more convenient than  $(160 \times 27) \div (75 \times 30)$ .

3. How many boxes  $4'' \times 4'' \times 6''$  (inside dimensions) can be filled by the contents of a box  $3' \times 2' \times 2'$ ?
4. How many garden plots each containing 24 sq. ft. can be made from a strip of land 126 ft. long by 4 ft. wide?
5. Study this problem and its solution:

A man bought a Novo sink for 75% of 60% of \$12.50 and a Special No. 2 sink for 80% of 50% of \$36. The Special No. 2 cost how many times as much as the Novo?

Express the problem in this way:  $\frac{.80 \times .50 \times 36}{.75 \times .60 \times 12.5}$

You can cancel with decimal numbers as accurately and easily as with whole numbers if you will think what the numbers mean.

Dividing by .20, you have 4 instead of .80 and 3 instead of .60.

Dividing by .25 you have 2 instead of .50 and 3 instead of .75.

Dividing by .5, you have 25 instead of 12.5 and 72 instead of 36.

Dividing by  $3 \times 3$ , you have 8 instead of 72.

$$4 \times 2 \times 8 = 64 \quad 64 \div 25 = 2.56$$

The Special costs 2.56 times as much as the Novo.

$$\frac{\overset{4}{\cancel{80}} \times \overset{2}{\cancel{50}} \times \overset{8}{\cancel{72}}}{\underset{3}{\cancel{75}} \times \underset{3}{\cancel{60}} \times \underset{25}{\cancel{12.5}}} = \frac{64}{25} \text{ or } 2.56$$

6. Check this result by multiplying and dividing in the ordinary way.

### 111. Commission

(Do as much of the work mentally as you can.)

If you sell articles for somebody and receive 3% of the money paid for the articles, the 3% of the money paid is your **commission**.

1. What will your commission be on a \$5 article?

If you collect \$20 on bills which people owe to your father and receive  $1\frac{1}{2}\%$  of the amount you collect, that 30¢ or  $1\frac{1}{2}\%$  of \$20 is your commission.

2. What will your commission be on collections of \$60?  
 3. If you induce 10 persons to pay \$2 each for a year's subscription to a magazine, and receive 30% commission, how much do you receive?  
 4. How much is received as commission in these cases?

- |  |  |
|--|--|
| a. 5% commission on \$1000.              | j. $\frac{1}{4}\%$ commission on \$400.    |
| b. 2% commission on \$1000.              | k. $\frac{3}{4}\%$ commission on \$400.    |
| c. $\frac{1}{2}\%$ commission on \$1000. | l. $\frac{1}{8}\%$ commission on \$60,000. |
| d. $\frac{1}{4}\%$ commission on \$1000. | m. 25% commission on \$2.00.               |
| e. $\frac{1}{8}\%$ commission on \$1000. | n. 15% commission on \$2.00.               |
| f. $\frac{1}{8}\%$ commission on \$2000. | o. 25% commission on \$1.50.               |
| g. $2\frac{1}{2}\%$ commission on \$60.  | p. $16\frac{2}{3}\%$ commission on \$1.50. |
| h. 3% commission on \$18.                | q. $33\frac{1}{3}\%$ commission on \$1.50. |
| i. $1\frac{1}{2}\%$ commission on \$400. | r. 3% commission on \$15.00.               |

*(Mental work.)*

1. Which of these means that a certain percent of the amount is subtracted from the amount?

- (a) \$8 less 20%. (b) At an advance of 12%. (c) At a reduction of 10%. (d) At a profit of 22%. (e) With 12% added. (f)  $\frac{1}{4}$  off. (g) With 15% discount. (h) Increased by 4%. (i) Subject to 2% discount.

2. Which of the phrases means that a certain percent of the amount is to be added to the amount?

3. Supply the missing numbers:

- |  |  |
|--|--|
| a. \$50 less 3% for cash =                     | j. A rise of 8% in wages for a man receiving \$4.00 a day means a gain of ... a day. |
| b. 20% reduction on \$7.50 =                   | k. \$15.00 less 2% for cash = ..   |
| c. A discount of $33\frac{1}{3}\%$ on \$100 =  | l. \$40 with 20% added for special speed = ...                                       |
| d. 80¢ a day, advanced 5%, becomes ...         | m. Regular price \$6. Special price at $\frac{1}{4}$ off = ...                       |
| e. \$3.00 wages increased 22% become ..        |  |
| f. $12\frac{1}{2}\%$ discount on \$10 =        |  |
| g. $16\frac{2}{3}\%$ discount on \$15 =        |  |
| h. A discount of $\frac{1}{5}$ on \$1.25 = ... |  |
| i. \$2.50 with a discount of 10% =             |  |

## 113.

*(Written work.)*

In each of these cases state whether the new price is at an advance or at a discount from the old price. Find what percent (of the old price) the advance or discount is. Find results to the third decimal place or tenths of a percent.

Old	New	Old	New	Old	New	Old	New
a. 25¢	32¢	g. 90¢	80¢	m. \$1.50	\$1.25	s. \$2.50	\$2.85
b. 30¢	36¢	h. \$1.00	85¢	n. 1.70	1.50	t. 5.75	5.25
c. 48¢	40¢	i. 1.10	\$1.25	o. 1.75	1.50	u. 6.00	3.94
d. 50¢	38¢	j. 1.25	.80	p. 2.00	1.48	v. 7.50	4.79
e. 68¢	50¢	k. 1.32	1.18	q. 2.00	1.79	w. 8.00	5.75
f. 75¢	65¢	l. 1.45	1.32	r. 2.25	1.75	x. 10.25	11.25



(Do the work mentally.)

When anybody has another person's money for a time and pays the money back with a certain percent of it added to it, he pays it back with **INTEREST**.

1. If you let some one have two dollars and he pays you back \$2.12, how much interest does he pay you?
2. What percent of \$2.00 does he add for interest?
3. If some one has \$3.00 of your father's money for 4 years and pays it back with 5% of it added for each year that he has it, how much does he pay back in all?

When we say "**\$100 with 4% interest**" or "**\$100 with interest at 4%**," we mean that 4% of the \$100 is paid for each year the person or bank has it.

4. At \$4 for using \$100 a year, how much would be paid—
  - (a) For using it 2 years? (b) For using it 6 months?
  - (c) For using it 3 months? (d) For using it 3 years?
5. Find the number of dollars to be paid as interest for the use of —

- |                                      |                                      |
|--------------------------------------|--------------------------------------|
| a. \$200 at 4% (per year) for 3 yr.  | i. \$100 at 6% (per year) for 2 yr.  |
| b. \$200 at 4% (per year) for 6 mo.  | j. \$100 at 3½% (per year) for 1 yr. |
| c. \$200 at 4% (per year) for 1½ yr. | k. \$100 at 5% (per year) for 1 yr.  |
| d. \$500 at 4% (per year) for 1 yr.  | l. \$100 at 5% (per year) for 6 mo.  |
| e. \$500 at 4% (per year) for 3 mo.  | m. \$20 at 4% (per year) for 1 yr.   |
| f. \$500 at 4% (per year) for 1½ yr. | n. \$80 at 4% (per year) for 3 mo.   |
| g. \$500 at 6% (per year) for 1 yr.  | o. \$25 at 4% (per year) for 6 mo.   |
| h. \$500 at 6% (per year) for 6 mo.  | p. \$300 at 6% (per year) for 4 yr.  |

When we speak of interest "*at 4%*" we mean *at 4% per year*.

When we speak of interest "*at 5%*" we mean *at 5% per year*.

When we speak of interest "*at 5½%*" we mean *at 5½% per year*.

6. Find the amount to be paid as interest for the use of:
 

a. \$100 for 2 yr. at 4%.	e. \$100 for 3 mo. at 4%.
b. \$100 for 1½ yr. at 4%.	f. \$100 for 2 mo. at 6%.
c. \$100 for 6 mo. at 6%.	g. \$100 for 1 mo. at 6%.
d. \$100 for 6 mo. at 3%.	h. \$100 for 3 yr. at 6%.



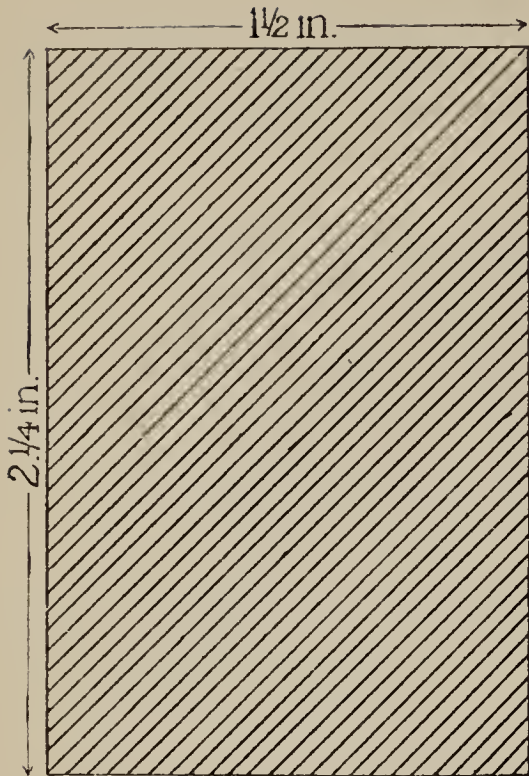

1. Find the area of the shaded rectangle.
2. Find its perimeter.
3. Find the volume in cu. in. of a block that just covers it and is  $2\frac{3}{4}$  in. high.
4. Tell which of these words or phrases mean the same or nearly the same as area. Which mean the same or nearly the same as perimeter? Which mean the same or nearly the same as volume?

*I. Distance around.*

*II. Size of a floor or garden.*

*III. Cubical contents.*

*IV. Sum of lengths of all sides.*

*V. Amount of surface.*

*VI. Capacity in cu. in. or cu. ft.*

*VII. Size of a box or trunk or room.*

5. Find the volume of each of these blocks of stone:
  - a.  $4' \times 9' \times 2'$ .
  - b.  $6' \times 3' \times 1\frac{1}{2}'$ .
  - c.  $9' \times 2' \times 9''$ .
  - d.  $2\frac{1}{2}' \times 3\frac{1}{3}' \times 12'$ .
  - e.  $3\frac{1}{4}' \times 1\frac{1}{3}' \times 1\frac{1}{2}'$ .
  - f. 1 ft. 9 in.  $\times$  4 ft. 6 in. by 2 ft. 4 in.
6. How many straight lines are required to make a triangle?
7. To make a quadrilateral?

A trapezoid is a quadrilateral with only one pair of opposite sides parallel.

A parallelogram is a quadrilateral with each pair of opposite sides parallel.

A rectangle is a quadrilateral with each pair of opposite sides parallel, and all its angles right angles.

A rectangle is a parallelogram with all four angles right angles.

A square is a rectangle with all four sides equal.

1. Make a tracing of the triangles and parallelograms and trapezoids below. Then take the lowest side as base and draw a line to show the altitude of each. Measure the altitude and base of each to the nearest eighth of an inch and find the areas, using these rules:

The area of a triangle =  $\frac{1}{2}$  of (base  $\times$  altitude).

The area of a parallelogram = base  $\times$  altitude.

The area of a trapezoid = ( $\frac{1}{2}$  of sum of parallel sides)  $\times$  altitude  
(one of the parallel sides being taken as the base).

2. Tell the missing words:

If the dimensions are expressed in inches, the area is sq. in.

If the dimensions are expressed in feet, the area is ...

If the dimensions are expressed in miles, the area is ...

If the dimensions are expressed in yards, the area is ...

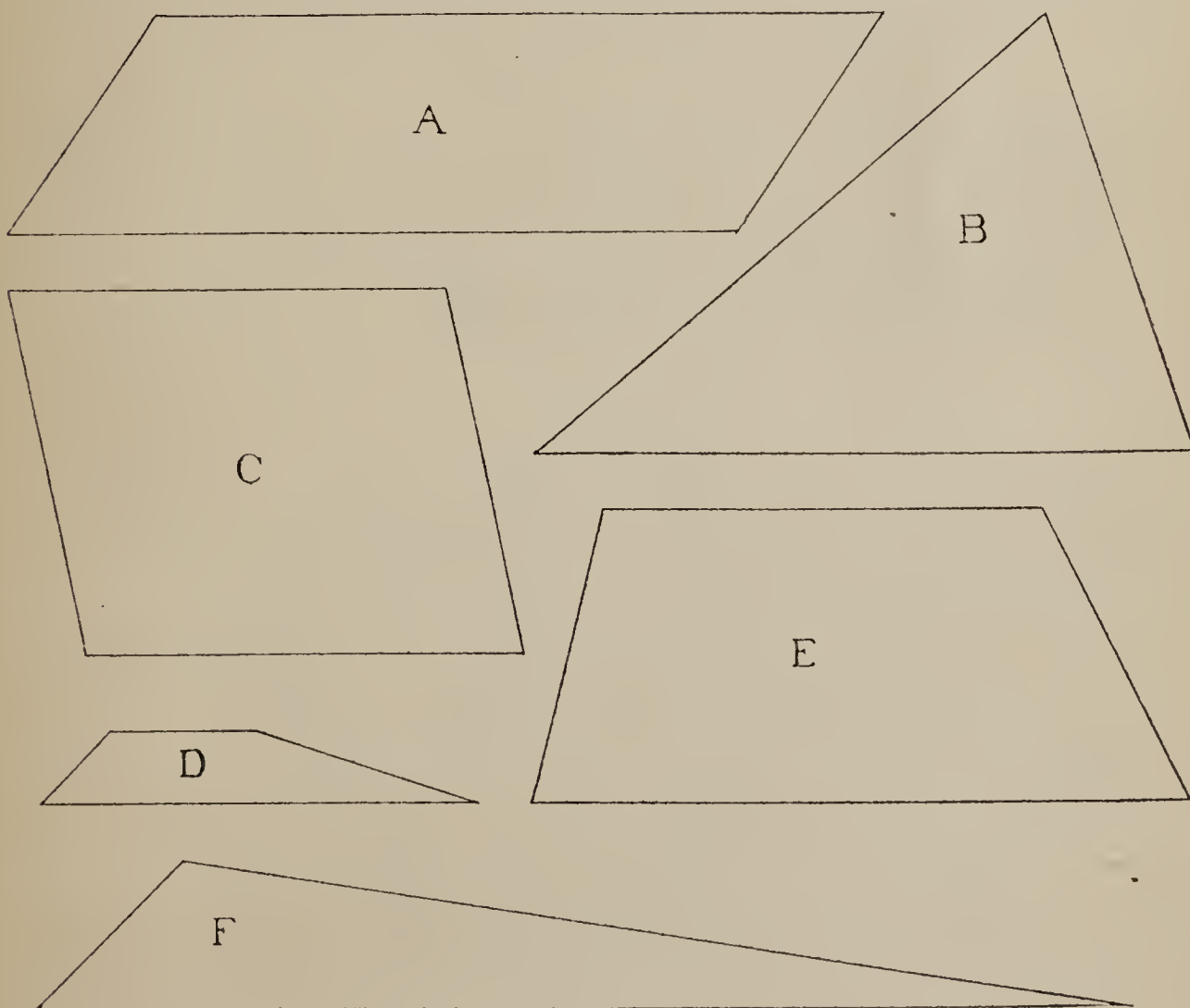

Find the area represented by each of these surfaces, counting each  $\frac{1}{4}$  in. as 1 mile and each  $\square$  as 1 sq. mi.

How can you check your results for this page?

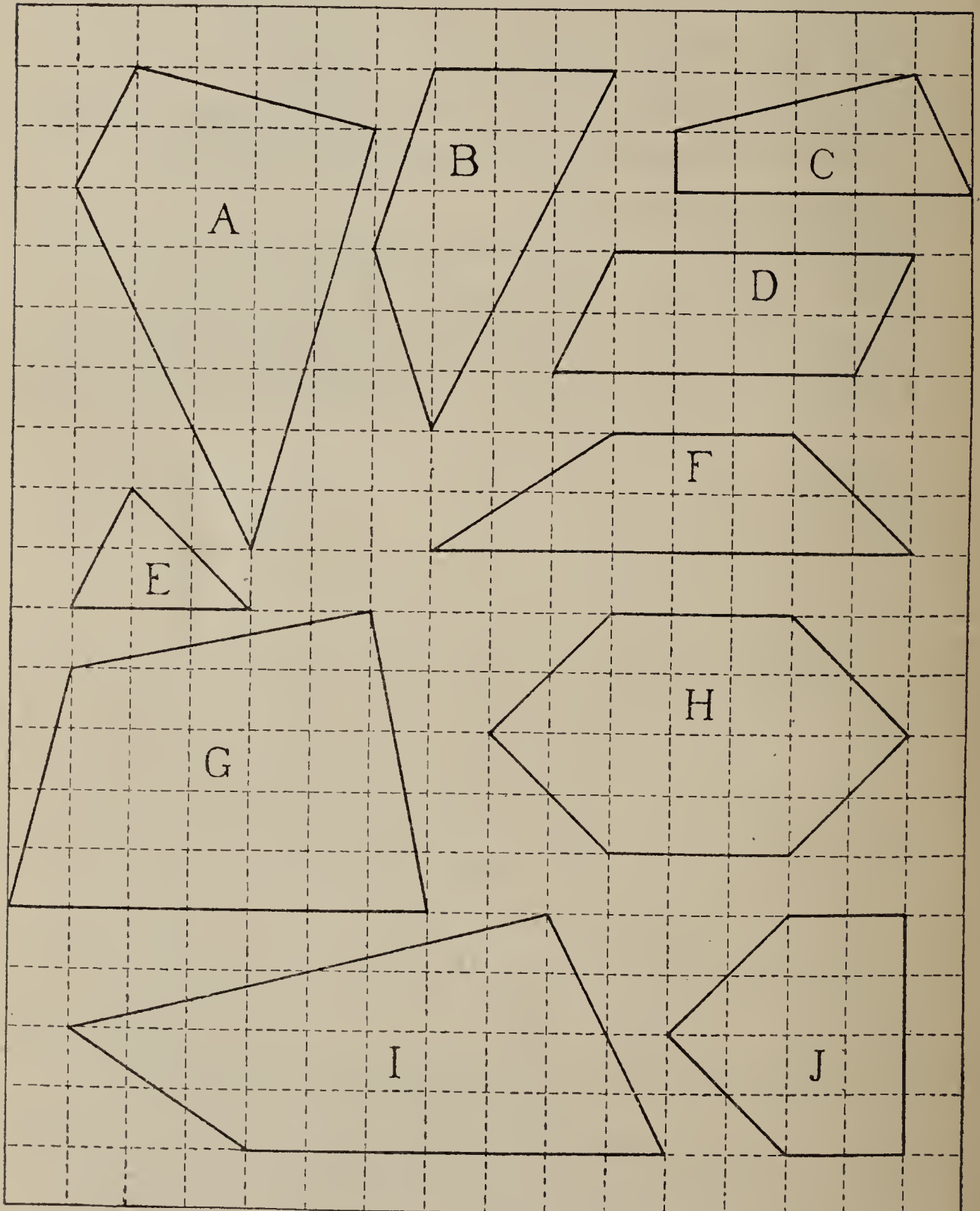

*(Mental work.)*

1. Examine these pairs:

$$\begin{array}{llll}
 a. \frac{6}{8} & \frac{12}{16} & b. \frac{6}{8} & \frac{3}{4} \\
 e. \frac{9}{12} & \frac{27}{36} & f. \frac{9}{12} & \frac{3}{4} \\
 i. \frac{5}{10} & \frac{10}{20} & j. \frac{5}{10} & \frac{1}{2}
 \end{array}
 \quad
 \begin{array}{llll}
 c. \frac{6}{8} & \frac{8}{10} & d. \frac{6}{8} & \frac{4}{6} \\
 g. \frac{9}{12} & \frac{12}{15} & h. \frac{9}{12} & \frac{6}{9} \\
 k. \frac{5}{10} & \frac{10}{15} & l. \frac{5}{10} & \frac{0}{5}
 \end{array}$$

2. Does it change the value of a fraction to multiply both terms (numerator and denominator) by the same number?
3. Does it change the value of a fraction to divide both terms (num. and denom.) by the same number?
4. Does it change the value of a fraction to add the same number to both terms? 5. To subtract the same number from both terms?
6. What do you do to both terms of a fraction when you cancel?

*(Written work.)*

7. Cancel and express as mixed numbers in lowest terms:

$$\begin{array}{lll}
 a. & b. & c. \\
 \frac{4 \times 15 \times 9}{6 \times 5 \times 7} & \frac{12 \times 10 \times 8}{25 \times 3 \times 2} & \frac{16 \times 9 \times 4}{5 \times 8 \times 6}
 \end{array}$$

## 119.

1. Write as many facts about 32 as you can in a minute, like this:
- 32 = 4 × 8  
 $\frac{1}{2}$  of 64  
 2 × 16  
 40 - 8  
 50 - 18  
 32 oz. = 2 lb.  
 etc.
2. Write as many facts as you can in a minute about each of these:
- a. 25      b. 16      c. 12  
 d. 100      e. 48      f. 15  
 g. 24      h. 33      i. 60  
 j. 5      k. 6      l. 10  
 m. 50      n. 12 $\frac{1}{2}$       o. 48  
 p.  $\frac{1}{2}$       q.  $\frac{3}{4}$       r. 66 $\frac{2}{3}$



Supply the missing numbers. Do all that you can mentally. Then use pencil and paper for the rest.

1. 4% of 60 means ...  $\times$  60.
2. 9% of 200 means ...  $\times$  200.
3. 6% of 70 = ...
4. 130% of \$1000 = ...
5. 7% of 50 ft. = ... ft.
6. 12 = ... % of 200.
7. 28 = ... % of 200.
8. 28 = 4% of ...
9. 9 = 3% of ...
10. 80 =  $\frac{2}{3}$  of ...
11. ... = 4% of \$300.
12. ... =  $33\frac{1}{3}$ % of \$600.
13.  $37\frac{1}{2}$ % of \$80 = ...
14.  $12\frac{1}{2}$ % of \$320 =
15.  $.06 \times \$40 =$
16.  $.06 \times \$52 =$
17.  $.66\frac{2}{3} \times \$60 =$
18.  $\frac{1}{2}$  of 4 =  $\frac{1}{3}$  of ...
19.  $\frac{1}{4}$  of 16 =  $\frac{1}{8}$  of ...
20. 22 = ... % of 50.
21. 3 for 5¢ is the same as 6 for ... ¢.
22. 6 for 25¢ is the same as 12 for ... ¢.
23. 2 for 5¢ is the same as 6 for ... ¢.
24. 4 for 25¢ is the same as ... for \$1.00.
25. 6 for 10¢ is the same as ... for 5¢.
26. 7 for 10¢ is the same as ... for 20¢.
27. 3 for 25¢ is the same as ... for \$1.00.
28.  $.12 \times 40 =$  ...
29.  $.015 \times 2000 =$  ...
30.  $\frac{2}{3} \times 20 =$  ...
31.  $.045 \times \$40$  is ... % of \$40.
32.  $2.3 \times \$40$  is ... % of \$40.
33.  $\$25 - (20\% \text{ of } \$25) =$  ...
34.  $12 - (\frac{1}{4} \text{ of } 12) =$  ...
35. 8% of \$22 = ...
36. 125% of \$20 = ...
37.  $.15 \times 1.10 =$  ...
38.  $.045 \times \$200 =$  ...
39. 15 = ... % of 50.
40. 15 = ... % of 25.
41. 15 = ... % of 200.
42. 15 = ... % of 20.
43. 40% of 30 = ...
44. \$15 less 10% of \$15 = ...
45. 80¢ plus 10% of 80¢ = ...
46.  $\frac{1}{2}$  of 10 = ... of 15.
47.  $\frac{1}{4}$  of 32 = ... of 40.
48.  $12 =$  ...  $\times$  6.
49.  $12 =$  ...  $\times$  8.
50.  $12 =$  ...  $\times$  36.
51. 2.1% of \$200 = ...
52. 3.1% of \$100 = ...
53.  $\frac{3}{5} \times 60 =$  ...
54.  $\frac{1}{3}$  of 12 = ... of 20.
55.  $\frac{3}{4}$  of 8 = ... of 12.
56.  $.6 \times \$.15 =$  ...
57.  $87\frac{1}{2}$ % of \$1.60 = ...

(Without pencil.)

1. Counting that 1 cu. ft. equals .8 bu., how many bushels will a bin hold that holds 90 cu. ft.?
2. How many bushels will a bin hold that is  $5' \times 4' \times 3'$ ?
3. Counting that 1 bu. =  $1\frac{1}{4}$  cu. ft., how deep will 100 bu. fill a bin that is 10 ft. long and 5 ft. wide?
4. Counting that 1 cu. ft. =  $7\frac{1}{2}$  gallons, how many gallons are there in a tank  $4' \times 3' \times 2'$  when it is half full?
5. Mr. Lewis found that his watch gained 25 sec. from 9 A.M. Monday to 9 P.M. Wednesday. How much did it gain per day?
6. Out of 40 pupils belonging to the class 8 were absent. What percent of the class was present?

(With pencil.)

Can you solve problems 7 to 11 correctly in 20 minutes or less?

7. The boys made a path through the woods that shortened the distance from the school to the pond from 1.24 mi. to .85 mi. By what percent of 1.24 mi. was the distance decreased?
8. The time taken is decreased only 18%, as the new road is over a hill. It used to take just half an hour. How long does it take now?
9. The Simplon tunnel is  $12\frac{1}{4}$  mi. long. The St. Gothard tunnel is  $9\frac{1}{3}$  mi. long. How many times as long as the Gothard tunnel is the Simplon tunnel?
10. The highest mountain in the world is 29,002 ft. high.  
(a) Express its height in miles. (b) If a road were built to the top of this mountain with an average grade or rise of 1 foot for every 20 feet of its length, how long would the road have to be?
11. What percent rise is 1 ft. in 40 ft. of length?

(Without pencil.)

Find the cost of —





1. 4 plows at \$15 each, less  $33\frac{1}{3}\%$  discount.
2. 9 roses, the price being \$1.00 a dozen.
3. 8 oranges, the price being 2 for 5 cents.
4. 125 plants, the price being \$3.00 per hundred.
5. A newsboy buys papers at the rate of 8 for 5¢ and sells them at 1¢ each. How much is his profit (a) If he sells 16? (b) If he sells 24?

(With pencil.)

6. How much is the newsboy's profit if he buys 40, sells all but 3 at 1¢ each, and sells these three to another boy for 1¢ for the lot?
7. A girl works from 5 P.M. to 6 P.M. every day except Saturday and Sunday, and from 6 P.M. to 9 P.M. Saturday. She receives \$1.00 a week. Is this more or less than 10¢ per hour?
8. A girl spent  $\frac{3}{5}$  of her salary for board and lodging and saved  $\frac{1}{10}$  of it. What percent of her salary did she have left to spend for clothes, laundry, church, amusements, etc.?
9. The Nortons live in a house that costs them \$20 per month, and \$50 a year for coal for the furnace. How much will they save per year by changing to a smaller house at \$16.50 per mo., which can be heated at a cost of \$35 per year?
10. How much will cloth for 8 curtains cost at 14¢ per yard if  $2\frac{5}{8}$  yd. are needed for each curtain?
11. A man who earns \$1200 a year spends 18% of his earnings for rent, and puts 8% of his earnings in the bank. How much does he have left per month to spend for food, clothing, church, books, etc.?



(Without pencil.)

- Which of these bars represents a mixture of A, B, and C in the proportions 2, 2, and 1?  50% 30% 20%
- Which represents a 3, 2, 1 mixture?  40% 40% 20%
- Which represents a 5, 3, 2 mixture?  50% 33 1/3% 16 2/3%
- Which represents a 4, 2, 1 mixture?  57.1% 28.6% 14.3%
- Draw a bar to show approximately an 80%, 15%, 5% mixture.

(With pencil.)

- What percent of the area shown in this map is playground?
- What percent is garden?
- What percent is swimming pool?
- What percent is covered by the school building?
- What percent is covered by the dormitory?
- A picture  $6 \times 4\frac{1}{4}$  in. is to be mounted on a sheet of cardboard so as to have a margin of  $1\frac{1}{2}$  in. at the top and bottom and  $1\frac{3}{4}$  in. at the sides. What will be the size of the sheet of cardboard?
- Estimate how many sq. yd. there are in the blackboard of your schoolroom. Then find the exact dimensions and the correct answer.
- Find the number of cubic feet of water in a swimming pool 32 ft. long, 16 ft. wide, and 7 ft. deep on the average.

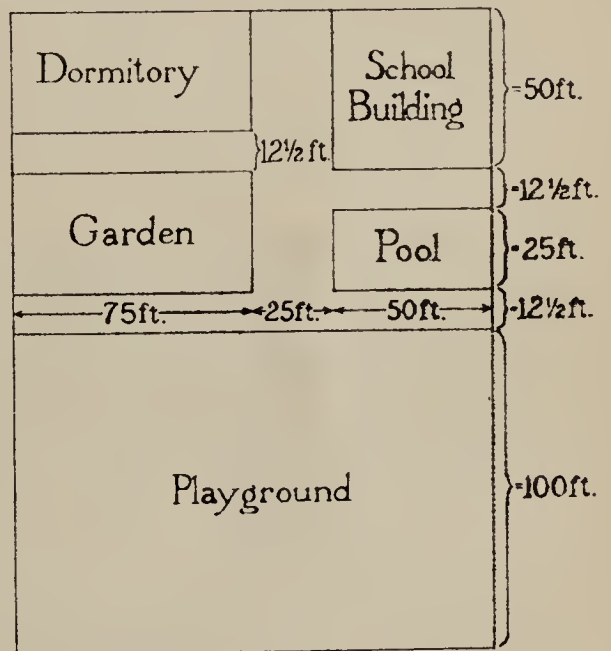



*June 22 has the longest daylight of any day in the year.*

*The sun rises at 4:29 and sets at 7:34.*

*Dec. 22 has the shortest daylight of any day.*

*The sun rises at 7:21 and sets at 4:35.*

1. How long is daylight (a) On June 22? (b) On Dec 22?
2. How many more hours of daylight are there on June 22 than on Dec. 22?
3. How many times as much daylight is there on June 22 as on Dec. 22?
4. What percent of the whole 24 hours is daylight (a) On June 22? (b) On Dec. 22?

The Lincoln School session for grade 6 lasts from 9 A.M. to noon and from 1 to 3 P.M. five days a week.

5. Find the percent of the school time spent on each of these:
  - a. Opening exercises, 10 min. each day.
  - b. Recess, 15 min. each day.
  - c. Dismissal, 5 min. each day.
  - d. Arithmetic, 45 min. each day.
  - e. English, 45 min. each day, and 30 min. extra on Fri.
  - f. Geography, 30 min. Mon., Wed., and Fri.; 45 min. Tu. and Th.
  - g. Physiology, 15 min. Mon., Wed., and Fri.
  - h. Study, 1 hr. 15 min. daily except Fri.; 1 hr. on Fri.
  - i. Hand Work, 1 hr. daily except Fri.; 45 min. on Fri.

In grade 6 of the Washington School—

*60 min. each day are spent on English.*

*15 min. each day are spent on Spelling.*

*30 min. each day are spent on Geography.*

*150 min. per week are spent in Shop Work.*

6. Which study has the same amount of time as shop work?
7. Which study has twice as much time as shop work?
8. Which study has half as much time as shop work?

1. Study this picture.

It is a rain meter or rain gauge that Edward made to measure the amount of rainfall. The pan is 4 in. long and  $2\frac{1}{2}$  in. wide. The tube is 1 inch square. All the water that falls on the pan runs down into the tube. After each rain Edward empties the tube.

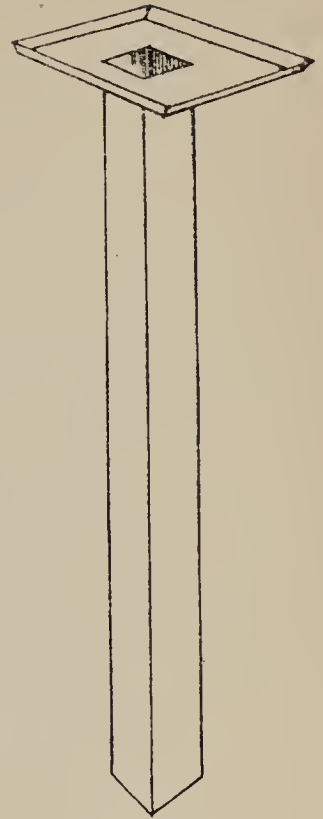

2. When 1 inch of rain falls on each sq. in. of the pan, how deep will it fill the tube?
3. When .467 in. of rain falls on each sq. in. of the pan how deep will it fill the tube?
4. If the tube is filled to a depth of 2.4 in., what was the rainfall per sq. in. of the pan?
5. If you keep the soil in a garden raked loose, the ground beneath will not dry out so fast. Supposing that 30 minutes of raking in a garden 20 ft. by 15 ft. kept a gallon of water from evaporating from each sq. ft. of the soil, how much would it save for the whole garden?
6. Helen brings water for her garden in a pail. She averages 2 gallons each trip. (a) How many trips must she make to bring a gallon for every square foot of her garden, which is 20' by 15'? (b) How long will it take her, counting 3 minutes per trip? (c) How much time would she save by raking the garden for a half hour instead of carrying the 300 gallons of water?
7. In some places the rainfall is only 6.2 in. per year. How many times as much is it in a place where 39.6 in. fall per year?











ROBE  
& CO