



NEW YORK STATE
GRADE 8
INTERMEDIATE-LEVEL
SCIENCE TEST

Manual for
Administrators and Teachers

2015 Written Test
Performance Test, Form A



The University of the State of New York
THE STATE EDUCATION DEPARTMENT
Albany, New York 12234 • www.nysed.gov

THE UNIVERSITY OF THE STATE OF NEW YORK

Regents of The University

MERRYL H. TISCH, <i>Chancellor</i> , B.A., M.A., Ed.D.	New York
ANTHONY S. BOTTAR, <i>Vice Chancellor</i> , B.A., J.D.	Syracuse
JAMES R. TALLON, JR., B.A., M.A.	Binghamton
ROGER B. TILLES, B.A., J.D.	Great Neck
CHARLES R. BENDIT, B.A.	Manhattan
BETTY A. ROSA, B.A., M.S. in Ed., M.S. in Ed., M.Ed., Ed.D.	Bronx
LESTER W. YOUNG, Jr., B.S., M.S., Ed. D.	Oakland Gardens
CHRISTINE D. CEA, B.A., M.A., Ph.D.	Staten Island
WADE S. NORWOOD, B.A.	Rochester
KATHLEEN M. CASHIN, B.S., M.S., Ed.D.	Brooklyn
JAMES E. COTTRELL, B.S., M.D.	New York
T. ANDREW BROWN, B.A., J.D.	Rochester
JOSEPHINE VICTORIA FINN, B.A., J.D.	Monticello
JUDITH CHIN, M.S. in Ed.	Little Neck
BEVERLY OUDERKIRK, B.S. in Ed, M.S., in Ed.	Morristown
CATHERINE COLLINS, R.N., N.P., B.S., M.S. in Ed, Ed. D.	Buffalo
JUDITH JOHNSON, B.A., M.A., C.A.S.	New Hempstead

ACTING COMMISSIONER OF EDUCATION

ELIZABETH R. BERLIN

Senior Deputy Commissioner for Education Policy

KEN WAGNER

Deputy Commissioner of Education, P-12

COSIMO TANGORRA

Assistant Commissioner, Office of Assessment, Standards and Curriculum

CANDACE H. SHYER

Director, Office of State Assessment

STEVEN E. KATZ

The State Education Department does not discriminate on the basis of age, color, religion, creed, disability, marital status, veteran status, national origin, race, gender, genetic predisposition or carrier status, or sexual orientation in its educational programs, services and activities. Portions of this publication can be made available in a variety of formats, including braille, large print or audio tape, upon request. Inquiries concerning this policy of nondiscrimination should be directed to the Department's Office for Diversity, Ethics, and Access, Room 530, Education Building, Albany, NY 12234.

Contents

General Features of the Grade 8 Intermediate-Level Science Test	1
Information for School Administrators	2
General Information.....	2
Test Forms.....	2
Scanning of Machine-Scorable Answer Sheets.....	2
Reporting Test Results.....	2
Administration Schedule.....	3
Students to Be Tested.....	3
Testing Accommodations.....	4
Security of the Tests.....	7
Test Certificates.....	7
Emergency Supply of Test Materials.....	8
Test Preparations and Other Guidelines	9
Administration of the Tests.....	9
Orientation of Test Administrators.....	9
Preparation of Students for Testing.....	9
Selecting the Testing Room(s).....	9
Preparation of the Testing Room(s).....	9
Supervision of Students.....	10
Determining the Need for Academic Intervention Services.....	12
Evaluating School Results on the Grade 8 Intermediate-Level Science Test.....	13
Recording Test Scores and Storing Student Answer Papers.....	13
Individual Student Results.....	13
Review of Answer Papers by Students and Parents.....	13
Online Submission of Teacher Evaluations of the Test to the Department.....	13
Return of Tests and Scoring Materials to the Department.....	14
Department Contacts.....	15
General Test Administration Procedures	16
Test Materials.....	16
Test Administration Time.....	16
Administering and Scoring the Written Test	17
Detailed Directions for Administering the Written Test.....	17
Scoring the Written Test, Parts I and II.....	19
Rating the Written Test, Part II.....	20
Organizing the Rating Process.....	20
Administering and Rating the Performance Test	22
Preparation.....	22
Preparing Each Station.....	25
Detailed Directions for Administering the Performance Test.....	34
Detailed Directions to Students Taking the Performance Test.....	35
Rating the Performance Test.....	39
Organizing the Rating Process.....	39

Finality of Teacher Scoring Committee’s Scores	40
Reporting Irregularities and/or Misadministrations	41
Mandatory Reporting of Testing Improprieties by Adults.....	41
Coding of Invalid Tests.....	42
Circumstances that Should Not Be Reported as Administrative Error.....	42
Appendix I: Materials Needed to Administer the Performance Test, Form A	43
Appendix II: Comparison of Possible Performance Test Sites	44
Appendix III: Test Administrator’s Record Sheet	45
Appendix IV: Station 1—Sorting Chart	47
Appendix V: Station 2—Ramp Place Mat	51
Appendix VI: Test Storage Certificate, Deputy and Proctor Certificate, Test Scoring Certificate	55
Appendix VII: Information on Ungraded Students	63
Appendix VIII: Suppliers for Grade 8 Intermediate-Level Science Performance Test Kits	64
Appendix IX: Performance Levels Chart	65

General Features of the Grade 8 Intermediate-Level Science Test

The Regulations of the Commissioner of Education provide that an intermediate-level science test is to be administered in Grade 8 to serve as a basis for determining students' need for academic intervention services in science. The Grade 8 Intermediate-Level Science Test is designed to measure the content and skills contained in the *Intermediate-Level Science Core Curriculum, Grades 5–8*. The core curriculum is based on the *New York State Learning Standards for Mathematics, Science, and Technology*.

The New York State Grade 8 Intermediate-Level Science Test consists of two required components: a Written Test and a Performance Test. The Written Test consists of multiple-choice and open-ended questions. Students will have two hours in which to complete the Written Test. The Performance Test (Form A) consists of hands-on tasks set up at three stations. Students will have 15 minutes to complete the tasks at each of the three stations, for an actual total testing time of 45 minutes. All three stations of the performance test must be administered in one continuous session. Teachers will need additional time for both the Written and Performance Tests to set up, distribute, and collect test materials and to provide instructions to students.

The first section of this manual contains information of special interest to administrators. Subsequent sections contain information on test preparations and other guidelines along with directions for administering and scoring the Written and Performance Tests.

Noteworthy Details:

- Please see page 6 regarding former English language learners.
- The Department's policy concerning the prohibition of student possession or use of communications devices during State tests is provided on pages 10 and 11.
- Please see page 19 for the Department's scoring policy.
- The procedure for reporting testing improprieties by adults is explained on page 41.

Information for School Administrators

General Information

All school personnel who will be involved in the administration and scoring of the Grade 8 Intermediate-Level Science Test should have a copy of and be familiar with the information in this manual. The manual may be photocopied by the school as needed. In addition, please check the Office of State Assessment's (OSA's) web site periodically at <http://www.p12.nysed.gov/assessment/> for possible updates. Schools may submit questions concerning the administration of the Grade 8 Intermediate-Level Science Test via e-mail to OSA at emscassessinfo@nysed.gov.

Pursuant to Section 102.3 of the Regulations of the Commissioner of Education, "Building principals are responsible for administering department examinations and maintaining the integrity of examination content and programs, in accordance with directions and procedures established by the commissioner."

Test Forms

Written Test: The Written Test booklet has two parts and should be administered in one sitting. Part I contains multiple-choice questions, and Part II contains open-ended questions. Students are allowed two hours of working time to complete the Written Test. In addition, the test administrator will need approximately 15 minutes to give directions to students. The Department will provide a new form of the Written Test each year. All schools must use an answer sheet developed by a RIC or large-city scanning center. Students must use this answer sheet to record their responses to the multiple-choice questions. Students write their answers to the questions in Part II of the Written Test in the test booklet.

Performance Test, Form A: The Performance Test consists of tasks at three stations which must be administered in one session. Each station requires 15 minutes of testing time, for a total testing time of 45 minutes. Additional time is needed to provide instructions to students and for students to move between stations. Allot at least one hour for administration of the Performance Test. The Performance Test is hand scorable only. Students write their answers to the questions on the Performance Test in the test booklet.

Scanning of Machine-Scorable Answer Sheets

It is the school's responsibility to make the necessary arrangements for scoring the test and reporting data to the Student Information Repository System (SIRS). All schools—public, nonpublic, and charter—must contract with a RIC or large-city scanning center for answer sheets, scanning, and reporting services. The school must send answer sheets to the RIC/large-city scanning center after the rating of the Written Test, Part II, and the Performance Test are completed.

Some schools will have two separate answer sheets, one for the Performance Test and one for the Written Test. If this is the case, both must be sent to the RIC/large-city scanning center if that is part of their arrangement. Schools may not require students to record their responses for the same multiple-choice questions on more than one answer sheet.

Reporting Test Results

Data for all schools must be reported through the SIRS. For more information about reporting results, school administrators should contact their local RIC or their large-city scanning center. **Schools must not send completed answer sheets to the Department.**

Administration Schedule

The Grade 8 Intermediate-Level Science Performance Test must be administered between May 20 and May 29, 2015. The specific date (within that timeframe) when the test is administered is a local decision. The Written Test must be administered on June 1, 2015. Students who are absent for the Performance Test on the specific administration date established by the school must be tested when they return to school, but no later than May 29. Similarly, students who are absent for the Written Test on June 1 must be tested when they return to school, but no later than June 3. Answer sheets for all students must be submitted to the scanning center by June 11, 2015.

Students to Be Tested

Except as noted below, all public and charter school students in Grades 3–8 must take all State assessments administered for their grade level. This includes students who have been retained in these grades. The birth dates of ungraded students with disabilities should be used to determine who must be tested and which grade-level test they will take (see Appendix VII). Nonpublic schools are also encouraged to participate and are to follow the same guidelines for each grade-level test they are administering. When determining which students will participate in these tests, be sure to consider students who attend programs operated by the Boards of Cooperative Educational Services (BOCES) as well as any other programs located outside the district.

- *Students with Disabilities.* The Committee on Special Education (CSE) must decide for each student, on a case-by-case basis, whether the student will participate in the general State assessment or in the New York State Alternate Assessment (NYSAA) for students with severe disabilities. The CSE's decision must be documented on the student's Individualized Education Program (IEP). The criteria that the CSE must use to determine eligibility for the NYSAA are available at the web site <http://www.p12.nysed.gov/assessment/nysaa/>. The Grade 8 Intermediate-Level Science Test answer sheets for students participating in the NYSAA should be coded as eligible for the Alternate Assessment.
- *Medically Excused.* A student may be medically excused from testing if documentation from a medical practitioner is obtained and kept on file at the school indicating that the student is too incapacitated to test at the school, at home, or in a medical setting. When reporting assessment data to the Department for a student who is medically excused, the principal must report the student's results with an Assessment Standard Achievement Code of "93" in SIRS.

The provisions of the No Child Left Behind Act (NCLB) do not permit any exemption of English language learners from the Grade 8 Intermediate-Level Science Test. This test is available in Chinese (Traditional), Haitian Creole, and Spanish. Information about administering these translated editions is included on page 16 under "Test Materials." The test can be translated orally into other languages for those English language learners whose first language is one for which a written translation is not available from the Department. Schools are permitted to offer English language learners specific testing accommodations when taking State tests to ensure valid and reliable test results (see pages 5–6).

The Grade 8 Intermediate-Level Science Test should be administered to students in the grade in which they will have completed all of the material in the *Intermediate-Level Science Core Curriculum, Grades 5–8*. While this grade is typically Grade 8, the test may also be administered to students in Grade 7 who will have completed by the end of this school year all of the material in the *Intermediate-Level Core Curriculum, Grades 5–8* and are being considered for placement in an accelerated high school level science course when they are in Grade 8. The inclusion of Grade 7 students who meet these criteria is a local decision. Schools can use the scores for these Grade 7 students to help determine whether students should be placed in accelerated science courses. Students who take the test in Grade 7 will not be permitted to take the test again in Grade 8. Therefore, caution is advised in administering the test to Grade 7 students. If a Grade 7 student scores below the State-designated level of performance, the student will be required to have academic intervention services the following year.

Schools are required to administer this assessment to those Grade 8 students who did not take this assessment last school year as Grade 7 students, unless such students will be taking a Regents Exam in science at the end of this school year. School principals have the discretion to either require or waive the Grade 8 Intermediate-Level Science Test for those accelerated Grade 8 students who did not take this test during the last school year but who will be taking a Regents Exam in science at the end of this school year. For those accelerated students for whom the principal waives the Grade 8 Intermediate-Level Science Test, the student's achievement in science will be measured by the student's performance on the Regents Exam in science.

Students who are repeating Grade 8 are required to take the test again.

Testing Accommodations

Students Who Incur Disabilities Shortly Before Test Administration

Principals may provide accommodations when testing general education students who incur an injury (e.g., broken arm) or experience the onset of either a short- or long-term disability (either cognitive or physical) within 30 days prior to test administration. Eligibility for such accommodations is based on the principal's professional judgment. The principal may confer with CSE/504 Multi-Disciplinary Team members, the school physician, or other school personnel in making such a determination. These accommodations must not significantly change the constructs/skills being tested and are limited to the following:

- extending the time limit for a test,
- administering the test in a special location,
- recording the student's answers in any manner, and
- reading the test to a student (only for a student whose vision is impaired).

Prior permission need not be obtained from the Department to authorize testing accommodations for general education students. However, a full written report concerning each authorization must be sent to OSA via fax to 518-474-1989. The report must be on school letterhead, must be signed by the principal, and must include the following information:

- the name of the student,
- the title of the test,
- a brief description of the student's injury or disability, and
- a listing of the accommodations that were authorized by the principal.

If the student is expected to continue to need testing accommodations, the principal must immediately make the appropriate referral for the consideration of an IEP or Section 504 Accommodation Plan (504 Plan).

Students with Disabilities

Students with disabilities must be provided with the testing accommodations specified in their IEPs or 504 Plans when taking this test. It is the principal's responsibility to ensure that this occurs and that those staff who will be providing these testing accommodations are appropriately trained. Plan all necessary arrangements for implementing testing accommodations well in advance of the test dates.

The Department's Office of Special Education provides more information on test access and accommodations for students with disabilities on its web site at <http://www.p12.nysed.gov/specialed/publications/policy/testaccess/policyguide.htm>. If you have questions on this topic for which you are unable to find answers on the web site, you may contact that office via e-mail to speced@nysed.gov.

Use of Scribes or Tape Recorders and Large-Type or Braille Editions

Instead of using a scribe, the Department encourages the use of a word processor (with dictionary disabled), as most students have some experience with computers, and word processing allows the student more control over his or her environment, fosters independence, and is less labor-intensive than using a scribe. However, the use of scribes and the use of tape recorders are allowable accommodations for the Grade 8 Intermediate-Level Science Test. Note the following procedures for scribing:

- The scribe must record word-for-word what the student dictates or records.
- The scribe must use lined paper and must write on every other line.
- The student must read the complete dictation/transcription and indicate on the skipped lines any further changes to be transcribed.
- The scribe must then transfer the student's completed response into the test book exactly as dictated or recorded and should attach the lined paper with the student's dictation to the back of the test booklet, preferably by stapling, to ensure against the student's response being lost.

For students who use large-type or braille editions of the test, or large-type answer sheets, teachers should transcribe the students' responses onto regular test answer sheets and test books exactly as dictated or recorded.

Use of Tablets

In order for students to use school-provided tablets during any part of the 2015 Intermediate-Level Science Test, schools must receive prior written approval from the Department. **No personal tablets are allowed.**

Format Changes

Any format changes to the text to be made by the school, such as the re-spacing of questions, enlargement beyond the standard large-type edition provided, colorization, etc., must receive prior written approval from the Department. Note that the reformatting of State assessments may never change the wording of questions, nor may additional examples be included.

In order for the Department to process requests for reformatting by the school, requests for approval should be submitted to OSA at least one week before the first scheduled date of the test administration. Requests should include a letter from the school on school letterhead signed by the school principal. Each request must include the portion of the student's IEP in which the type of reformatting is listed or defined. Requests may be faxed to 518-474-1989. Department approvals will be provided by fax. However, regardless of approval, under no circumstances may the shrink-wrapped test packages of State assessments be opened prior to the morning of the day that the test is to be administered in the school.

English Language Learners

Schools may provide the following testing accommodations to English language learners:

- *Time Extension:* Schools may extend the test time for English language learners. Principals may use any reasonable extensions, such as "time and a half" (the required testing time plus one-half of that amount of time), in accordance with their best judgment about the needs of the English language learners. Principals should consult with each student's classroom teacher in making these determinations.
- *Separate Location:* Schools are encouraged to provide optimal testing environments and facilities for all students. They may administer State tests to English language learners individually or in small groups in a separate location.
- *Bilingual Dictionaries and Glossaries:* English language learners may use bilingual dictionaries and glossaries when taking this test. The bilingual dictionaries and glossaries may provide **only**

direct translations of words. Bilingual dictionaries or glossaries that provide definitions or explanations are **not** permitted.

- *Translated Editions:* English language learners may be provided with a translated edition of the Grade 8 Science Test. This test is available in Chinese (Traditional), Haitian Creole, and Spanish. In addition, English language learners may use both an English and an alternative language edition of the test simultaneously. However, they should be carefully instructed to record all of their responses in only one of the two editions. The alternative language edition used by the student should be so indicated on the student's answer sheet.
- *Oral Translation for Lower Incidence Languages:* Schools may provide English language learners with an oral translation of this test when there is no translated edition provided by the Department. All translations must be oral, direct translations of the English edition; written translations are not allowed. No clarifications or explanations may be provided. Translators should receive copies of the English edition of the test *one hour prior* to administration. The Department's Office of Bilingual Education and Foreign Language Studies (telephone 518-474-8775) and the Regional Bilingual Education Resource Networks (RBE-RNs) can assist schools in locating suitable translators. A list of RBE-RNs is available at <http://www.p12.nysed.gov/biling/bilinged/betac.html>.
- *Writing Responses in the Native Language:* English language learners may write their responses to the open-ended questions in their native language. Scoring the responses to the open-ended questions is the responsibility of the school. However, the Department's Office of Bilingual Education and Foreign Language Studies and the RBE-RNs can assist schools in locating persons who can translate the students' responses into English to facilitate scoring of the answer papers.

Former English Language Learners

Schools may provide the testing accommodations listed above under the heading "English Language Learners" to former English language learners who met the exiting criteria specified in Part 154-2 of the Regulations of the Commissioner of Education and were exited from English language learner status following their participation in one of the two most recent administrations (Spring 2013 or Spring 2014) of the New York State English as a Second Language Achievement Test (NYSESLAT). Such students either achieved an overall level of Proficient on the NYSESLAT or, effective October 1, 2014, achieved an overall level of Advanced on the most recent administration of the NYSESLAT and scored at Level 3 or higher on the New York State Common Core Grades 3–8 English Language Arts Test. For each English language learner or eligible former English language learner, darken the circles on the answer sheet in the box labeled "ELL Accommodations" to indicate the testing accommodations provided.

These accommodations may not be provided to former English language learners who were identified as English language proficient prior to the 2013 NYSESLAT administration.

Security of the Tests

Prior to Testing

Secure test materials will arrive about two to three school days before testing at the secure facility designated by the principal via the online Examination Request System. Prior to these delivery dates, the principal should make arrangements to be notified when the test materials arrive.

Safeguarding Test Materials

The sealed packages of secure test materials must be stored in a secure place at the location indicated on the *Test Storage Plan* submitted to the Department. As soon as practical after delivery, an inventory of the test materials must be conducted. The sealed packages of secure test materials must be placed back inside the secure location immediately after the inventory is completed. The school principal must notify the Department in writing via fax to 518-474-1989 if any of the packages of secure test materials are not properly sealed when received. The sealed packages of secure test booklets may **not** be opened until the test administration date, and then just early enough to permit the distribution of booklets prior to the scheduled starting time.

All Written Test booklets, both used and unused, and all used answer sheets must be held secure from the date the school receives its shipment of test materials until 3:00 p.m. on June 3, 2015 at which time the Rating Guide will be posted on the Department's web site at <http://www.p12.nysed.gov/assessment/>. Once the Department-designated test administration period has ended, the Written Test materials are no longer considered secure.

All Performance Test materials must be kept secure except during the actual administration and scoring of the Performance Test. Scoring materials for the Performance Test will be sent to schools along with the test booklets. The same Performance Test (Form A) will be administered for several years, and all Performance Test materials **except** student test booklets are to be returned to the Department.

To minimize the number of testing irregularities, principals should conduct a review of the test administration procedures prior to each test administration with all faculty and staff who will be involved in the test administration and scoring. In addition, to preserve the integrity of the test, advise all teachers administering and scoring this test that they are not to discuss test questions or other specific test content online via e-mail or LISTSERV or through any other electronic means. Teachers and test administrators may not use cell phones or other photographic devices to duplicate test materials, and should keep their own communication devices put away during testing, using them only in emergency situations. Please note that shrink-wrapped packages of test books cannot be opened prior to the distribution of tests to students.

Test Certificates

The *Test Storage Certificate*, the *Deputy and Proctor Certificate*, and the *Test Scoring Certificate* must be completed and signed by all of the appropriate parties following the administration and scoring of the Performance Test and again following the administration and scoring of the Written Test. Both sets of signed certificates must be retained in the school's files for one year. Copies of these certificates can be found in Appendix VI. The *Test Scoring Certificate* may be copied and **must** be completed for each test administered. All scorers for each test and the principal are required to sign this form to indicate compliance with all scoring procedures as outlined in the scoring keys and rating guides for each test.

Emergency Supply of Test Materials

All shipments of secure test materials should be inventoried immediately after delivery and before being placed in secure storage. After taking inventory:

1. If you determine that any items listed on your shipping notice are **missing** from your shipment, circle the item(s) and quantity that are missing on the notice and fax the corrected shipping notice to the Department's Operations Group at 518-474-2021. (No cover sheet is necessary.) The missing item(s) will be sent to your school's storage site.
2. If the school requires items that were **not originally requested**, or items necessary to accommodate students of whose needs the school was not previously aware, contact the Department's Operations Group by sending a fax to 518-474-2021. The Operations Group will determine whether the regional center has the materials necessary to satisfy the additional request. After contacting the Operations Group, the school should contact the official in charge of the regional center to arrange pickup of test materials on the day of test administration.
 - The official school representative picking up secure test material must present to the regional center official a photo ID and a letter of authorization signed by the principal listing the materials to be picked up. This letter, authorizing the school representative to pick up test materials, must be written on school stationery. (**Note:** Secure materials can be obtained from the regional center only on the day that they will be administered.)
 - The school representative must countersign the authorization letter and leave it with the regional center official before the emergency supply of materials can be released.
 - Information on regional centers is available at <http://www.p12.nysed.gov/assessment/ei/eigen.html>.

Please note: Performance Test material will not be sent to Regional Centers, only to schools.

Test Preparations and Other Guidelines

Administration of the Tests

To ensure that the Grade 8 Intermediate-Level Science Test provides an accurate measure of student achievement, both students and teachers should be properly prepared for its administration. This manual provides suggestions for preparing students to take the tests. School personnel who administer the Written and Performance Tests must be familiar with the test materials and the directions for administration provided in this manual.

Orientation of Test Administrators

This manual is not secure; copies of this publication should be distributed to teachers in advance of the administration date(s) so they may familiarize themselves with the procedures for administering the test. Schools may make photocopies of this publication if necessary. It is also available at <http://www.p12.nysed.gov/assessment/manuals/>.

In addition, schedule an orientation prior to the testing dates to enable test administrators to become adequately prepared. The orientation should include direct hands-on experience with the Performance Test if the test administrators have not had previous experience with that component of the test. BOCES or large-city central offices may provide assistance for conducting such orientation sessions.

Note regarding test security: Allow access to the Performance Test materials only to those who are scheduled to administer the Performance Test, conduct the orientation, or rate the test. **These materials must remain under strict security conditions at all times to preclude access to the test materials by students and other unauthorized persons.**

Preparation of Students for Testing

The administration of the test should be announced to students before the date that the test is scheduled to be administered. All announcements should be made in such a way as to increase the students' interest in the test without causing them to become overly anxious. In addition, parents should be informed of the dates of testing and the purpose of the tests. Parents should be asked to encourage students to do their best on the test and to ensure that students are well rested on the days of testing. Students should be familiar with the general types of questions on the test and the procedures that they should follow when recording the answers to the test questions. Previous editions of the Written Test that feature questions similar to those that will be on this year's test are available on the Department's web site at <http://www.nysedregents.org/Grade8/Science/>.

Selecting the Testing Room(s)

Arrangements for administering the tests should interfere as little as possible with the normal school routine. The Written Test may be administered in the students' regular classroom, or classes may be arranged into smaller or larger groups, at the convenience of the school. The Performance Test need only be set up in one location. For buildings with more than one class of Grade 8 students, classes should cycle through the testing area one at a time. Suggestions for selecting an appropriate testing site for the Performance Test are provided in the section of this manual entitled "Administering and Rating the Performance Test" (pages 22–23) and in Appendix II.

Preparation of the Testing Room(s)

The room(s) in which the tests are administered should be well lighted, well ventilated, and quiet. Make preparations before the testing period to keep noise and other distractions to a minimum. Place a "Do Not Disturb" sign on the door to prevent interruptions. If tests are to be administered in a classroom, clear desks and shelves under the desks of all books, papers, and other materials. Completely cover or remove from the walls all charts and blank or completed graphic organizers pertinent to science and all board work. Make arrangements in advance to seat the students so that each student will be clearly visible to the proctor at all times and so that there will be the least possible opportunity for any communication between students. Seating of students in alternate rows is recommended.

Supervision of Students

Unauthorized Materials

Students should be under close supervision at all times during the administration of the tests and may not use any unauthorized notes, printed materials, scrap paper or tools.

Use of Communications Devices

All students are prohibited from bringing cell phones and certain other electronic devices, as defined in the script below, into a classroom or other location where a State test is being administered. Test proctors and school officials shall retain the right to collect and hold any prohibited electronic devices prior to the start of the test administration. Admission to the test shall be denied to any student who is in possession of a cell phone or other prohibited electronic device and refuses to relinquish it.

At the beginning of each test session, proctors must read the following statement to all students taking State tests:

You cannot have any communications device, including a cell phone, with you during this test or during any breaks (such as a restroom visit). Such devices include, but are not limited to:

- Cell phones
- Blackberry devices and other PDAs
- iPods and MP3 players
- iPads, tablets, and other eReaders
- Laptops, notebooks, or any other personal computing devices
- Cameras or other photographic equipment
- Headphones, headsets, or in-ear headphones such as earbuds
- Any other device capable of recording audio, photographic or video content, or capable of viewing or playing back such content

If you brought any of these items to the building today, and have not already stored it in your locker or turned it over to me or a school official, you must give it to me now. You may not keep your cell phone or any of these items with you, or near you, including in your pockets, backpack, desk, etc. If you keep a cell phone or any of these items with you, your exam will be invalidated and you will get no score. Is there anyone who needs to give me any of these items now?

[Proctor: repeat list of devices.]

This is your last opportunity to do so before the test begins.

Any student observed with any prohibited device while taking a State test must be directed to turn the device over to the proctor immediately. To allow for all possible outcomes of procedural due process, the student should be allowed to complete the test. The incident must be reported promptly to the school principal. If the student had a prohibited device in his or her possession during the test administration, the principal must invalidate the student's test score (no score may be calculated for that student), and report the incident to OSA.

The incident must be promptly reported, in writing, to OSA via fax to 518-474-1989 or by e-mail to emscassessinfo@nysed.gov, as is the case for all student-related testing irregularities, misadministrations, or other violations of State testing policy and procedures.

Note: Some students with disabilities may use certain recording/playback devices **only if** this accommodation is specifically required as a provision of the student's IEP or 504 Plan. In addition, a student may be allowed to retain an otherwise prohibited device in his or her possession if there is documentation on file at the school from a medical practitioner that the student requires such a device during testing. Without such documentation, the general policy on communications devices as provided above is in effect, and the school may not allow the student to retain any such equipment while testing.

Aid to Students

No one, under any circumstances, may interpret or explain test questions to students, nor may anyone review or comment to the student about the correctness or sufficiency of the student's response while the test is in progress. In response to inquiries by students concerning the meaning or interpretation of test questions, proctors should advise students to use their own best judgment. Teachers may give students assistance only in the mechanics of taking the test, such as understanding that their multiple-choice responses must be recorded only on the answer sheet and their constructed responses must be recorded in the test book.

Temporary Absence from Testing Room

No student may be permitted to leave and then return to the testing room during any part of the test unless the student is accompanied by a proctor for the duration of his or her absence from the testing room.

Emergency Evacuation of a School Building

Evacuation of a school building during a test may be required because of an emergency such as a fire alarm or bomb threat. In any situation in which the safety of the students is endangered, the principal has full authority to interrupt the test immediately. If it is possible, the students should be kept under supervision during the emergency. If work can be resumed following evacuation then students may make up the remaining time so that they will have the allotted time on the test. Following the test, a written report of the circumstances should be faxed to OSA. (See "Reporting Irregularities and/or Misadministrations" on page 41.)

Student Cheating

Do not permit students to obtain information from or give information to other students in any way during the test. If the proctor suspects that such an attempt has occurred, the proctor should warn the students that any further attempts will result in the termination of their tests. If necessary, the proctor should move the students to another location. If these steps fail to end attempts to obtain or give information, the proctor should notify the principal immediately and terminate the students' tests. At the conclusion of the test, all suspected cheating must be reported to the principal.

If, in the judgment of the principal, a student has attempted to give aid to or obtain aid from another person during the test, the principal must follow the school's disciplinary procedure for student cheating and invalidate the student's test. Score reports will not be produced for invalidated tests. When reporting student assessment data to the Department under such circumstances, the principal must report the student's test result as "administrative error." (See "Coding of Invalid Tests" on page 42.)

Illness

If a student becomes ill during a part of the test, the student should be excused until he or she is well enough to continue. The principal should estimate the time that the student had remaining to complete that part of the test. When the student is well enough to complete the test (and as long as the testing or makeup period has not ended), the student may be given the remaining time for that part. When the student is finishing the test, the student must be closely supervised so that he or she does not go back to previously completed questions on the test.

Students Absent on the Test Day

Plan to administer the test at a later date during the test administration or makeup period to all students who were absent when the test was initially given. Do not involve these students in any classroom discussions about the test prior to the time they take it.

Proctoring

Proctors must circulate periodically around the room during the administration of each session of the test to ensure that students are recording their responses to test questions in the proper manner and in the proper place. While circulating around the room, proctors should make sure that students are recording their responses to the multiple-choice questions on their answer sheets and their constructed responses in their test books. Students are not to record their multiple-choice responses in their test books. Proctors should also point out to students that they have left one or more answers blank or have darkened more than one circle for the same multiple-choice question. However, proctors may **not** comment to the student on the correctness or sufficiency of any answer.

No additional time is to be provided to students to transfer answers from test books to answer sheets at the end of the test, and no one, other than the student, may transfer answers marked in his or her test book to the multiple-choice answer sheet (the latter does not apply to students whose IEP or 504 Plan allows scribes to transfer answers from the test book to an answer sheet).

No one, under any circumstances, including the student, may alter the student's responses on the test once the student has handed in his or her test materials. Teachers and administrators who engage in inappropriate conduct with respect to administering and scoring State tests may be subject to disciplinary actions in accordance with Sections 3020 and 3020-a of Education Law or to action against their certification pursuant to Part 83 of the Regulations of the Commissioner of Education.

Determining the Need for Academic Intervention Services

Section 100.2(ee)(i) of the Regulations of the Commissioner of Education requires schools to provide academic intervention services to students who score below the State-designated performance level (performance level 3, final test score 65) on the Grade 8 Intermediate-Level Science Test. All students who achieve a final score in performance levels 1 and 2 (see Appendix IX) must receive academic intervention services. These services must commence in the semester immediately following the administration of the test. Charter schools are exempt from this provision. Providing academic intervention services is not mandated for nonpublic schools.

Academic intervention services are intended to assist students who are at risk of not achieving the State learning standards in English language arts, mathematics, social studies and/or science, or who are at risk of not gaining the knowledge and skills needed to meet or exceed designated performance levels on State assessments. Academic intervention services shall be made available to students with disabilities on the same basis as non-disabled students, provided that these services are in accordance with the student's IEP. The regulations also require that the parent or guardian of each such student shall be notified in writing, by the principal, of the academic intervention services to be provided to the student, the reason the student needs such services, and the consequences of not achieving expected performance levels. Such notification must be provided in the language best understood by the parent or guardian.

In the fall of 2010, the Board of Regents amended the regulations regarding academic intervention services (§100.2 (ee)) to allow school districts to replace, in whole or in part, academic intervention services with Response to Intervention (RtI). A school district that chooses to do so must file an *LEA Response to Intervention Assurance Form* with the Department indicating the buildings, grades, and subject that RtI will be used in place of academic intervention services. School districts must also agree to adhere to the requirements in §100.2 (ii), which defines the RtI process. Information on this option can be found at <http://www.p12.nysed.gov/docs/ais-rti.html>.

Evaluating School Results on the Grade 8 Intermediate-Level Science Test

The Rating Guides for the Written and Performance Tests provide summary charts that link each test question to the Intermediate-Level Science Core Curriculum. The core curriculum is based on the *New York State Learning Standards for Mathematics, Science, and Technology (Intermediate-Level)*. The charts provide a reference to these documents for each question on the Written and Performance Tests.

Recording Test Scores and Storing Student Answer Papers

Schools must maintain complete and accurate records of students' test scores. A student's score and the date of administration must be entered on the student's permanent record.

All schools must keep their students' Performance Test booklets on file in the school for at least one year. Since the Performance Test booklets remain secure, they must be stored in a secure location. Schools must also keep their students' Written Test answer sheets on file for the same period of time.

Individual Student Results

At the school's earliest opportunity after tests have been scored, schools are expected to provide test results to each student's parent/guardian.

Review of Answer Papers by Students and Parents

Students and parents/guardians of students who have taken the Grade 8 Intermediate-Level Science Test have the right to review student answer papers after the scores have been recorded as described in the preceding section. Answer papers should be reviewed in the presence of the principal, or the principal's designee, to ensure that no changes are made on the answer papers as they are being reviewed.

Online Submission of Teacher Evaluations of the Test to the Department

Suggestions and feedback from teachers provide an important contribution to the test development process. The Department provides an online evaluation form for State assessments where teachers may respond to several specific questions and may make suggestions. Go to <http://www.p12.nysed.gov/assessment/teacher/evaluation.html> to complete and submit your evaluation.

Return of Tests and Scoring Materials to the Department

Written Test: Since the Department will provide a new form of the Written Test each year, schools do **not** have to return Written Test materials to the Department. After the Department-designated test administration period has ended and the test has been scored, schools may use the Written Test as part of the instructional program. Schools may make photocopies of the Written Test if additional copies are needed for this purpose. All schools must keep student answer papers for the Written Test on file in the school for one year. Copies of this manual, the Rating Guide, and the Test Storage, Deputy and Proctor and Test Scoring Certificates for the Written Test should be kept on file at the school with the students' answer papers for reference. **No school should send answer sheets to the address listed below for the return of certain Performance Test materials.**

Performance Test: Principals are required to ensure that the school returns Performance Test materials to the Department as indicated in the chart below.

Return to the Department's Test Distribution Unit	Retain in the School Do NOT return to the Department
All <i>unused</i> Performance Test booklets, including regular, large-type, braille, and alternative language editions All used and unused Performance Test Rating Guides	Performance Test booklets used by students Test Administrator's Record Sheet Copies of this test administration manual Completed Test Storage Certificate Completed Deputy and Proctor Certificate Completed Test Scoring Certificate

The Performance Test materials must be returned at your school's expense after scoring has concluded but no later than June 17, 2015. For your convenience, a pre-addressed return label was enclosed with the shipment of test materials to return the Performance Test materials to:

Test Distribution Unit
New York State Education Department
Cultural Education Center, Room 167
Empire State Plaza
Albany, New York 12230

Note: New York City public schools should follow the procedures for the return of Performance Test materials provided to them by the New York City Department of Education.

Department Contacts

Different Department staff are responsible for various aspects of the test. Direct questions to one of the persons or offices listed below.

Do not discuss test questions or other specific test content via e-mail. This is a violation of security, as stated on page 7. Questions about scoring should be addressed by telephone.

Test Administration:	Emily Bryans, Test Administration 518-474-5902 emily.bryans@nysed.gov
Rating/Scoring:	Cily Rueda, Test Development Unit 518-474-5900 cily.rueda@nysed.gov
Requests for Additional Test Materials	Operations Group Fax a copy of shipping notice with a note itemizing which materials are needed to: 518-474-2021
Content/Curriculum:	Office of Curriculum and Instruction (C&I) 518-474-5922 emscurric@nysed.gov
Accommodations for Students with Disabilities	Special Education Policy and Professional Development 518-473-2878 speced@nysed.gov
Reporting Results in SIRS	Information and Reporting Services 518-474-7965 dataquest@nysed.gov
Academic Intervention Services	David Bryant, Office of Innovative Programs, Student Support Services 518-486-6801 david.bryant@nysed.gov

General Test Administration Procedures

Test Materials

The test materials provided by the Department for administering the Grade 8 Intermediate-Level Science Test include:

For the Written Test:

- test booklets
- directions for administering and scoring the Written Test (pages 17–21 of this manual)

NOTE: Answer sheets are provided by your school's RIC/large-city scanning center (see page 2).

Schools will no longer receive printed scoring materials for the Written Test. The Scoring Key for the Written Test Part I and the Rating Guide for the Written Test Part II will be posted on the Department's web site at <http://www.p12.nysed.gov/assessment/> at approximately 3:00 p.m. on June 3, 2015. Schools must print sufficient copies to supply one to each rater.

For the Performance Test (Form A):

- test booklets
- Station Diagrams (10 sets of each of these Station Diagrams and one Test Administrator's Record Sheet)
- directions for administering and rating the Performance Test (pages 22–39 of this manual)
- Test Administrator's Record Sheet (Appendix III of this manual)
- Rating Guide for the Performance Test (Form A)

The Written Test booklet and the test booklet and Station Diagrams for the Performance Test (Form A) are available in large-type and braille as well as in the following alternative language editions: Chinese (Traditional), Haitian Creole, and Spanish. The alternative language editions are direct translations of the English editions. The directions to students on the alternative language test materials are the same as those on the English editions. The Department does not provide separate directions for administering the alternative language editions of the tests. Teachers who speak the language should be able to administer the alternative language editions by using a copy of the test materials in the appropriate language and the directions provided in this manual. If a teacher who does not speak the alternative language administers the tests, the directions on the test materials should enable students to complete the tests by themselves.

The test materials to be provided by the school include pencils for both the Written and Performance Tests and the station materials for the Performance Test.

Test Administration Time

Written Test: Students are allowed two hours of working time to complete the Written Test. In addition, the test administrator will need approximately 15 minutes to give directions to students.

Performance Test, Form A: The Performance Test should be administered in a 45-minute time period. Field testing has determined that almost all students will complete the tasks at all three stations in this amount of time. In addition, the test administrator will need approximately 15 minutes to give directions to students. All stations must be administered in one session.

Administering and Scoring the Written Test

Detailed Directions for Administering the Written Test

Make sure that sufficient quantities of all test materials are on hand. The following materials are needed:

for each student

- test booklet
- answer sheet
- No. 2 pencil
- calculator (**Note:** Calculators *may* be needed for some questions. If so, four-function calculators are sufficient. Scientific calculators are permitted. Graphing calculators are *not* permitted.)

for the test administrator

- detailed directions for administering and scoring the Written Test (pages 17–21 of this manual)
- test booklet (for demonstration purposes)
- answer sheet (for demonstration purposes)
- extra answer sheets and No. 2 pencils

At the beginning of each test session, proctors must read the following statement to all students taking State tests:

You cannot have any communications device, including a cell phone, with you during this test or during any breaks (such as a restroom visit). Such devices include, but are not limited to:

- Cell phones
- Blackberry devices and other PDAs
- iPods and MP3 players
- iPads, tablets, and other eReaders
- Laptops, notebooks, or any other personal computing devices
- Cameras or other photographic equipment
- Headphones, headsets, or in-ear headphones such as earbuds
- Any other device capable of recording audio, photographic or video content, or capable of viewing or playing back such content

If you brought any of these items to the building today, and have not already stored it in your locker or turned it over to me or a school official, you must give it to me now. You may not keep your cell phone or any of these items with you, or near you, including in your pockets, backpack, desk, etc. If you keep a cell phone or any of these items with you, your exam will be invalidated and you will get no score. Is there anyone who needs to give me any of these items now?

[Proctor: repeat list of devices.]

This is your last opportunity to do so before the test begins.

After the desks have been cleared of books and papers and when the students are ready to begin, say:

Today you are going to take a test in science. I will now give each of you a test booklet face up on your desk. Write your name and school on the cover. Do not open the booklet until I tell you to do so.

Distribute one test booklet, face up, to each student. Then say:

I will now give out the answer sheets. Please do not write on the answer sheet until I tell you what to do.

Now, read the directions on the cover and on page 3 of the test booklet.

After the answer sheets have been distributed, give directions for completing the heading of the answer sheet. Provide directions for marking any machine-readable name or number grids. These directions *must* be developed by the school.

If students do not understand how to mark the answer sheet, explain the appropriate directions until everyone knows what to do. Then say:

Look at the cover of your test booklet. Be sure it says "Grade 8 Intermediate-Level Science Test, Written Test, June 1, 2015." Check that your booklet is complete and that no pages are stuck together. If you do not have the correct book or a complete book, raise your hand.

When I tell you to, turn to page 4 and begin work. When you are finished, close your test booklet and place it on top of your answer sheet.

Now, turn the page and begin work.

Begin timing the two hours now. Note the time on a clock and record the time on the chalkboard or on a sheet of paper. A sample is shown below.

Start time: _____

Stop time: _____

Stop time less 15 minutes: _____

Stop time less 5 minutes: _____

Walk around the room and make sure that all students understand the directions and are properly marking their answer sheets. Explain again the test-taking procedures to any student who appears to be having difficulty.

No one, under any circumstances, may interpret or explain test questions to students, nor may anyone review or comment on the answer paper of a student while a test is in progress. In response to inquiries by students concerning the meaning or interpretation of test questions, students should be advised to use their own best judgment.

When 15 minutes remain, say:

You have 15 minutes left.

When 5 minutes remain, say:

You have 5 minutes left.

When the time is up, say:

Stop work. Put down your pencil. Close your test booklet and place it over your answer sheet.

Students should remain quietly at their desks when they finish the test. The teacher may collect the test materials either as students complete the test or when most of the students have finished.

If the test is administered in a large-group setting, school administrators may prefer to allow students to hand in their test materials as they finish and then leave the room. If so, take care that students leave the room as quietly as possible so as not to disturb the students who are still working on the test.

Note: No one, *under any circumstances*, including the student, may alter the student's responses on the test once the student has handed in his or her test materials. Teachers and administrators who engage in inappropriate conduct with respect to administering and scoring State tests may be subject to disciplinary actions in accordance with Sections 3020 and 3020-a of Education Law or to action against their certification pursuant to Part 83 of the Regulations of the Commissioner of Education.

Scoring the Written Test, Parts I and II

NOTE: Teachers are **not** permitted to score their own student's answer papers.

The Scoring Key for the Written Test Part I and the Rating Guide for the Written Test Part II will be posted on the Department's web site at <http://www.p12.nysed.gov/assessment/> at approximately 3:00 p.m. on June 3, 2015.

Part I—All schools administering the Grade 8 Intermediate-Level Science Test are required to make arrangements to obtain answer sheets and associated scanning services from a RIC or large-city scanning center. These centers will scan and score the answer sheets according to the following criteria:

1. One credit will be awarded for each correct answer.
2. Credit will not be allowed if two or more answers have been marked for the same questions.
3. The raw score for Part I will be determined by counting the number of correct responses.

Part II—assign credits as indicated in the Rating Guide for the Written Test Part II. A list of criteria for rating the open-ended questions on Part II is provided in that guide.

Machine Scoring. Schools should be sure to check with their scoring center concerning the procedure to be followed in preparing the answer sheets for machine scoring.

The separate answer sheet containing the multiple-choice answer grids also provides grids for recording a student's Part II and Performance Test scores. When filled in, these grids enable scoring centers to produce student records that include final student scores. Record the Performance Test scores in these grids **after** the Written Test is administered but before the answer sheets are machine scored. If schools have two separate answer sheets for the Written and Performance Tests, both must be sent to the RIC or large-city scanning center.

Determining the Student's Final Test Score. A chart for converting the student's Written Test raw score and Performance Test raw score to a final score will be provided on the Department's web site at <http://www.p12.nysed.gov/assessment/> at approximately 3:00 p.m. on June 3, 2015. Once a final score has been determined for each student, a performance level can be assigned. The Performance Levels Chart is provided in Appendix IX of this manual.

Note: The final score corresponding to the raw scores in the conversion chart will change with each year's edition of the test. For this reason, it is crucial that for each test year only the conversion chart provided for that edition be used to determine the student's final score.

Rating the Written Test, Part II

Approximately one-half of the questions on the Written Test will be open-ended. A group of teachers should rate the Part II open-ended questions on the Grade 8 Intermediate-Level Science Test. There must be at least two raters. No rater assigned to score a student's test responses may be that student's teacher. School administrators decide who can rate Grade 8 Intermediate-Level Science Test(s) after review of the teacher's certification, and present and past teaching assignments. It is estimated that two teachers working as a team should be able to rate all of the open-ended responses for about 20 students in approximately one hour.

The Rating Guide for the Written Test, Part II gives detailed directions for rating the open-ended section of the Written Test and specific criteria for rating each question. In rating the students' test booklets, each rater should follow the procedures detailed in the rating guide. The rating should be completed prior to June 11, the date when answer sheets must be submitted to the scanning centers. Copies of the Written Test Rating Guides should be kept on file at the school for reference for at least one year.

Organizing the Rating Process

The following is a suggested procedure for managing the mechanics of the rating process.

1. Designate one person as the coordinator of the rating process. The coordinator may be appointed at either the building or the district level. He or she will be responsible for training and supervising raters and may also rate some of the questions in the student test booklets.
2. Set aside one room as a central rating room for collecting, sorting, circulating, and storing test booklets and for preparing and maintaining records.
3. Provide adequate time for rating during the school day.
4. Make sure each rater receives approximately the same number of student booklets, taking care to ensure that no teacher is assigned to rate the test booklets of his or her own students.
5. At least two teachers must participate in rating the open-ended questions in Part II. Each should be responsible for rating a selected number of the open-ended questions in each test booklet. No one teacher is to score more than half of all the open-ended questions in a student's test booklet.

6. Prior to the rating of students' responses to the open-ended questions in Part II, allow time to provide training for all raters (even if they have received prior training). If possible, select at random 10–15 student test books and duplicate them for use as a “warm-up” exercise with the raters for discussion of the questions, the criteria, and the rating of each item. During the training exercise, after three or four complete student test booklets have been rated, ask the raters to indicate, by a show of hands, how many credits they gave each response. If there is some disagreement about the number of credits to be awarded a response, ask raters who gave different credits to a response to explain their rating by citing specific criteria from the rating guide.

Administering and Rating the Performance Test

Preparation

Well in Advance of the Test Date:

1. Notify teachers and other staff of this test, the role that each will have, and that test security measures must be maintained. Notify other professionals and support staff of this test and the role that they may need to play.
2. Assemble and prepare all equipment according to the directions (pages 25–33) in this manual. The materials listed specify what is needed for a single station. Some commercial and public suppliers have constructed kits that provide *most* of the specific equipment for each station. Appendix VIII provides a list of these suppliers. Although kits ordered from suppliers should generally be the same, some kits may not be ready for immediate use, and additional time may be needed for preparation. The school may need to provide some miscellaneous materials such as marking pens, tape, or labels.
3. Check the materials well in advance of the test date. Contact the supplier for a replacement if a piece of equipment or material is missing or arrives broken.
4. Check to be sure that the equipment and materials are adequate for the number of students to be tested. Appendix I provides a complete list of materials needed for each station. A supplier's kit of materials usually provides for a maximum of 30 students. Each group of stations will accommodate three students, and students will move to each station within the group. If 30 students are to participate in the Performance Test, you will need equipment for 10 complete setups of each station. Each student will need one test booklet and a sharpened pencil. Check that enough booklets will be available for the number of students to be tested. Test administrators should have an extra supply of sharpened pencils on hand.
5. Check the equipment schools must provide: triple-beam balances, compound microscopes with at least two objectives, and handheld calculators. Make sure that all balances can be "zeroed," all microscopes are in good working order, and all calculators have an energy source. The microscopes should have an eyepiece with 10× magnification, a lowest-power objective of 4× magnification, and a highest-power objective of about 10× magnification. Overall, the microscopes should give total magnifications of about 40× and about 100×.
6. Select and reserve a testing room. Once all the equipment has been prepared, it should take three to four work-hours to set up the room, one hour to conduct the assessment (for a class of 30 students), and one hour to disassemble the setup. For larger schools and schools where the test will be given early in the school day, station setup can be done the day before and secured overnight. Do *not* leave test booklets out overnight.
7. **Plan the layout of the room and prepare a diagram of the layout of the stations. This is an essential step in the process of performance testing.** The testing room must have flat top student work spaces (student tables, lab tables, library tables, or cafeteria tables) in sufficient numbers for the number of students to be tested. An individual student desk may be too small to accommodate all the equipment for a station plus provide room for the student to write. It may be possible to place two smaller individual desks together to make a larger work area for one station. Determine how many tables will be needed and how they will be arranged in groups of three stations each (see page 24). The room may need to be large enough to accommodate 8–10 groups (24–30 students) comfortably. Students will need to move (either sideways or front-to-back) among stations within their group with as little confusion as possible. An important consideration is the location of Station 1, which requires the use of a microscope. If the microscope uses a mirror, it should be positioned so that it has enough light but not direct sunlight. If it has an electrical light source, it must be positioned near an electrical outlet.

8. Check that all print materials from the Department are ready. These include the student test booklets, directions for setting up the stations, detailed directions for administering the test, Station Diagrams for Stations 1, 2, and 3, and a Rating Guide.
9. Check that at least two adult test administrators (two professionals, or one professional and one paraprofessional) have been trained and are completely familiar with the test protocols and the equipment. These adults will administer the test, direct student movement, and handle equipment issues. In addition, teachers or aides may be present to provide testing accommodations to students with disabilities pursuant to their IEPs. They should also receive training regarding the procedures used in this assessment. To minimize possible distractions during the testing, other adults should *not* be invited to attend.

One Day Prior to the Test or Early Morning on the Test Date:

1. Prepare a diagram of the room layout of the stations.
2. Arrange the tables into groups of three stations each. Remember that natural or artificial lighting is needed for the microscopes, so locate all Station 1 setups first. Set up each station according to the directions provided in the section of this manual entitled “Preparing Each Station,” pages 25–33. The materials listed specify what is needed at each station for each group that is being tested. The stations do not need to be in numerical order. Arrange the equipment exactly as it is shown on the Station Diagram.
3. Assign a group number to each set of Stations 1, 2, and 3. Use this numbering system to tell students which group they are in. This number will be recorded on the cover of each student’s test booklet. The group number will be important when rating students’ responses based on specific materials. For Group 1, the station setups should include Block B–1 and Slide X–1; for Group 2, the station setups should include Block B–2 and Slide X–2; etc.
4. Write the school name on the chalkboard so that students can correctly and quickly record it in their test booklets.
5. Instruct students *not* to bring any items with them to the testing room. However, reserve a location near the door for the quick placement of items that students might bring with them, such as books, bookbags, and coats.
6. Give students the opportunity to visit the restrooms prior to the testing session.
7. Place a sharpened pencil and one copy of the student test booklet face down at each station just before students enter the room. Have a supply of sharpened pencils available.
8. **Safety:** Staff should exercise the same safety precautions that apply when students engage in performance tasks in a science classroom. Students should be monitored closely for safe use of equipment and materials at all times.
9. **Complete the Test Administrator’s Record Sheet. This information is *very important*. It will be used to determine the range of correct answers by the teachers rating the students’ tests. A copy is provided in Appendix III of this manual.**

Partial Diagrams of Typical Classroom Setups Three Typical Group Setups

Electrical Outlets or Windows

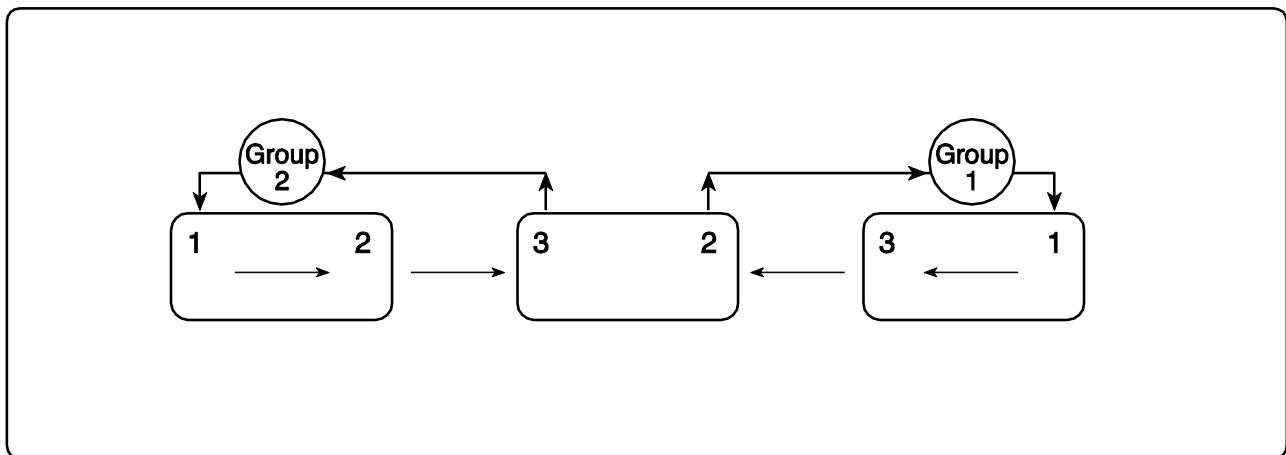
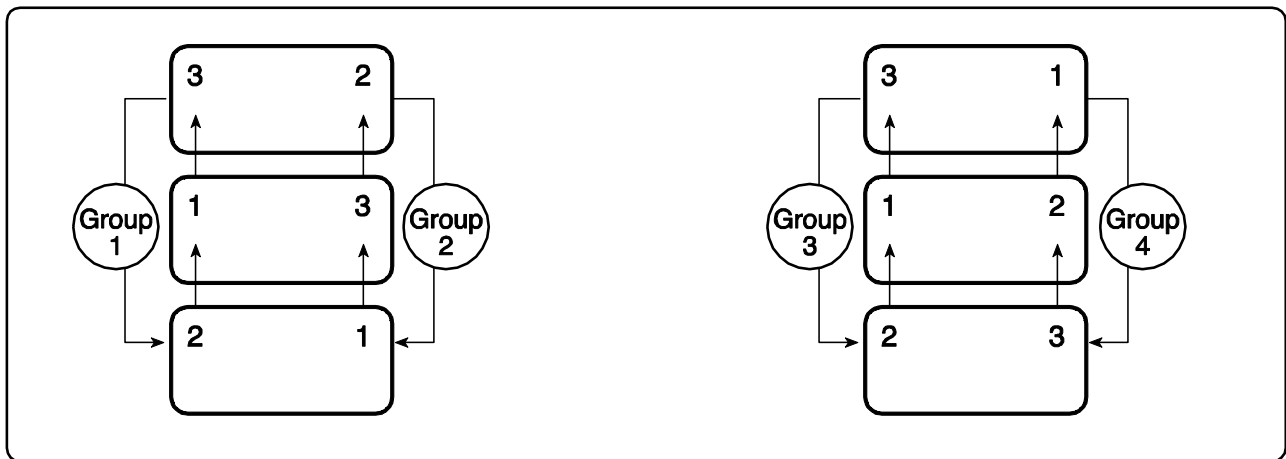
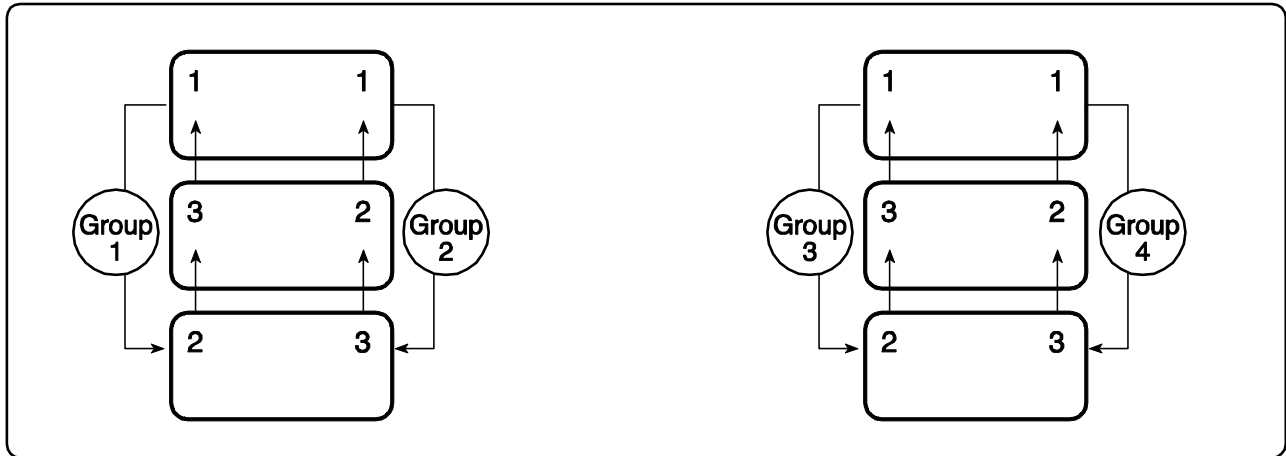

Windows

Electrical Outlets

Preparing Each Station

The detailed directions listed below include a list of the materials needed for each station, a Station Diagram, and specific suggestions for preparing the materials and setting up the stations. Refer to the diagram of the setup for your testing room to determine how many individual station setups you will need.

Station 1: Sorting Creatures

Materials needed for *one* station:

- Black permanent marker
- Collection of six specific plastic creatures
- Index card (3"×5", unlined)
- Masking tape
- Microscope with an eyepiece of 10× and at least two lenses providing total magnification of about 40× and 100×
- Slide A—slide of grid with 1-mm squares (graph paper)
- Slide X—microscopic specimen: (recommend *Drosophila*—**must clearly show** six legs)
- Sorting Chart (8½" × 14"), preferably laminated

Preparation to be done prior to the test date:

1. When setting up the room, determine the location of this station first. This is important because the microscope may need an electrical outlet for a light source or good natural lighting if it uses mirrors. Do *not* place microscopes where direct sunlight could hit the mirror and reflect into a student's eye.
2. Appendix IV provides a master for the Sorting Chart. It should be on an 8½" × 14" sheet of paper (preferably laminated).
3. Use a black permanent marker to label each of the six specific plastic models with its corresponding letter. Place the capital letter on the underside of each creature. (**Note:** These models are available from the suppliers listed in Appendix VIII.)

A—centipede

D—ant

B—fly

E—spider

C—dragonfly

F—bristletail

4. The microscope should have an eyepiece of 10×. The lowest power objective should provide about 4× magnification. The highest power objective should provide about 10× magnification. These will provide total magnifications of about 40× and about 100×. If the microscope has a higher objective than these two, it should be covered so that students will not use it. This can be done by wrapping a piece of lens paper over it and securing the paper with masking tape.

Note: Microscopes in a school's inventory may have a total lowest magnification of 100×. These should work if students are accustomed to moving specimens across the field of view to determine measurements. You must also provide a second objective larger than 10×. If a microscope has only two objectives, 10× and 40×, both of these objectives should be available for the student's use; neither should be covered.

5. Prepare a Slide A for each Station 1. This is a permanent slide that can be made from a section of graph paper ruled every 1.0 mm. Cut out a 1.0-cm \times 1.0-cm section of the graph paper. Use clear transparent tape to mount the graph-paper section in the center of the blank slide. Label this Slide A. Place Slide A on the index card. (**Note:** Some suppliers may provide slides with grid lines printed directly onto the slides.)
6. Prepare a Slide X for each Station 1. Dry and mount a *Drosophila* under a coverslip so that all six legs are clearly visible. Specimens should be approximately 2–2.5 mm in length. (These specimens are available commercially.)
7. Use consecutive numbers to label the microscopes 1, 2, 3, etc. These numbers will indicate which group used that microscope. Fill out the Test Administrator's Record Sheet (Appendix III) for each microscope by recording the lowest power and the field of view to the nearest 0.5 mm.
8. Use consecutive numbers to label the Slide X samples, e.g., X–1, X–2, X–3, etc. These numbers will indicate which group observed that slide. Place Slide X on the index card.
9. Once a Slide X has been placed at each Station 1, examine the slides under lowest power *using the microscope at that station*. In the table on the Test Administrator's Record Sheet, record the length of the *Drosophila* on each slide to the nearest 0.5 mm. A simple method for determining the length of the *Drosophila* is to place Slide A on the microscope stage and place Slide X on top of it. Focusing on these two slides will easily show the size of the *Drosophila*. **Note:** Some of the *Drosophila* specimens are bent and could be measured by adding the two sections or by measuring across from head to end. Do *not* include the antennae, legs, and wings. If possible, replace these slides. If not, make a note of both values on the Test Administrator's Record Sheet. For example:

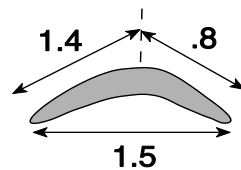

(Not drawn to scale)

If the specimens were bent as illustrated above, both 1.5 ± 0.5 mm or 2.2 ± 0.5 mm can be accepted.

10. Use masking tape to secure the Station Diagram in the lower left corner of the desk/table.
11. Place the equipment at the station so its location agrees with the Station Diagram on page 27.

Safety:

1. When positioning a microscope with a mirror, be sure that the mirror will not be pointed directly at the Sun at any time during the testing sessions.
2. Alert students about handling sharp-edged microscope slides.
3. Monitor the students for safe use of the microscopes.
4. If electrical extension cords are used, take care that students do not trip or push against them as they move among stations. If necessary, tape the cords to the floor and/or flag them so that they can be easily seen.
5. Do not place electrical lights or extension cords near water faucets.

Station Diagram

Station 1: Sorting Creatures

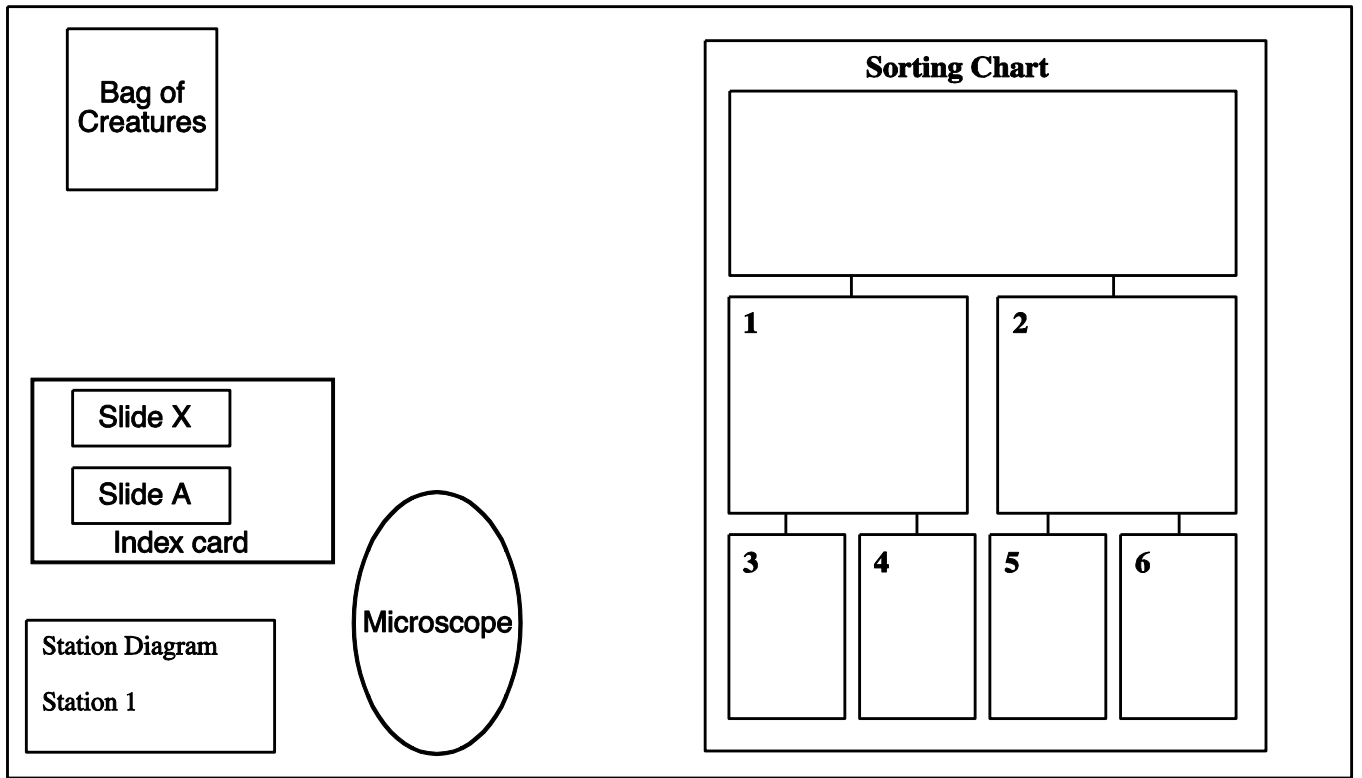

Station 2: Ramp and Golf Ball

Materials needed for *one* station:

- Black permanent marker
- Carpet tape or duct tape
- 5-gram mass or 25-cent coin
- Golf ball
- Masking tape
- Resealable plastic bag
- Ping-Pong ball
- Place mat with measuring strip
- Round plastic container with hole
- Ruler with groove (metric)
- Support block(s)
- Labels

Preparation to be done prior to the test date:

1. The round plastic container should be transparent or translucent, about 12 cm in diameter (1-pint size), and about 15 g in mass, e.g., a deli container. From the rim, cut a hole (about 6 cm × 6 cm) to allow enough room for the golf ball to roll inside. (Some vendors may have already done this step.) This is the front of the cup.



2. The grooved plastic ruler serves as the ramp for rolling the golf ball. Allow only the metric units to show on the ruler. Cover the standard units (inches) with black permanent marker or duct tape. Be sure the tape does not get into the groove of the ruler, as it may interfere with the roll of the ball. The ruler's zero mark should be at the end of the ruler, *not* indented.
3. Appendix V (pages 51–53) provides a master for the place mat. Make it on an 11" × 17" sheet of paper (preferably laminated).
4. A block of wood about 5–6 cm in height will serve as the ramp support.
5. Assemble the ramp setup as described below, but do *not* tape any equipment down until everything has been put in place and tested. The ramp must be set up so the ball does not push the cup off the table.
6. Use masking tape to secure the Station Diagram in the lower left corner of the desk/table. Refer to the diagram when setting up the station.
7. Place the ruler's 28–29-cm mark at the edge of the ramp support and the ruler's zero mark on the table. Slip the place mat under the ruler so that it is aligned with the "End of Ramp Ruler" mark (about 1 cm inside the edge of the place mat).
8. Place the ramp support to the back and far left of a level desk/table so that the ruler will slope down from upper left to lower right. The ruler's numbers must be on the side of the ruler nearest the students (even if the numbers are upside down). If the numbers are not on the student's side, reverse the ramp position to the back and right of the desk. (**Note:** If this is the case, the Station Diagram will not exactly match the setup.) Place the ramp back far enough on the desk/table so that the student has plenty of room to write in the test booklet.
9. Place the cup on the place mat's "Starting Circle" 1 cm away from the end of the ruler, with the cup's opening toward the ruler.

10. Place a 5-g mass or a 25-cent coin on the top of the cup and secure it in two directions with masking tape. Try rolling the golf ball from the 28–29-cm mark. The back rim of the cup should slide and stop beyond the 15-cm mark on the place mat. Release the ball from the 10-cm and 25-cm marks to be sure to have a good range of values for the distance that the cup slides. (If the ramp is too steep, the ball will bounce down the ramp and onto the table, giving inconsistent results.)
11. Once you have determined the correct height of the ramp, tape down the corners of the place mat. Then tape the base of the support block(s) to the table. Use carpet tape to secure the bottom of the block. If using duct tape (or masking tape), secure strips of tape against the side of the block. Do this on all four sides of the block. (If the block should slip during setup, reset the block by using the ruler as a guide to the place mat.) On the underside of the ruler at the 0-cm and the 29-cm marks, place carpet tape to secure the ruler. (You can also use duct tape or masking tape that has been rolled back on itself so there are two sticky sides.) When the ruler is put into place, its 0-cm mark should be on the place mat and the support should be at the 28–29-cm mark. Place two additional strips of tape across the ruler at the 29-cm mark, following the ruler's contour, and secure it to the support. If the tape is too tight, this will lift the other end of the ruler off the place mat.
12. Release the golf ball from the 29-cm mark again to be sure that the whole system is working correctly and the cup is not pushed off the table.
Note: As more students use the setup, the place mat may become smoother, and the cup will travel farther.
13. Place the golf ball into a transparent, resealable bag that is labeled “Golf Ball,” and put it on the desk/table.
14. Place a Ping-Pong ball into a transparent, resealable bag that is labeled “Ping-Pong Ball” and “Do Not Open.” Use masking tape or duct tape to cover the seal on the bag so that it cannot be opened. The test administrator will give a Ping-Pong ball to the student upon request.
15. Place the equipment at the station so its location agrees with the Station Diagram on the next page.

Safety: Routine laboratory safety procedures are required.

Station Diagram Station 2: Ramp and Golf Ball

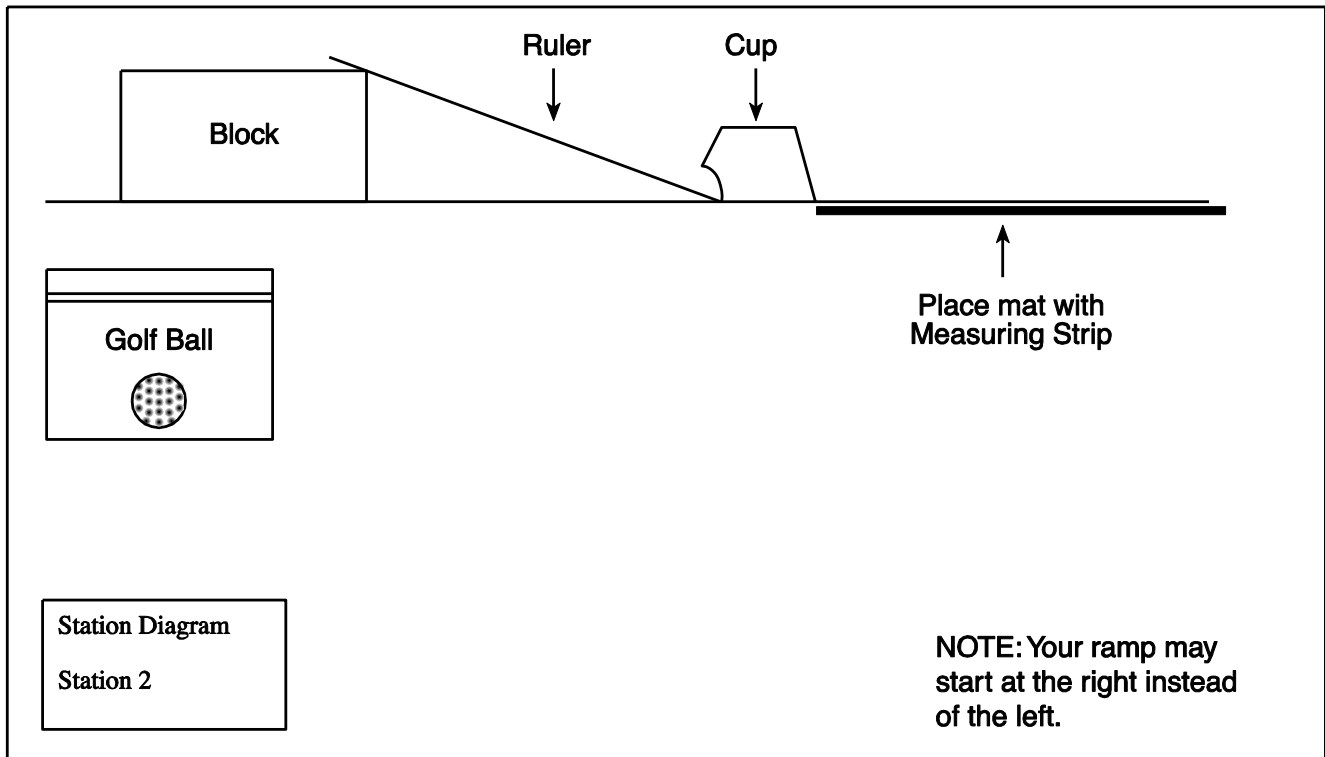

Station 3: Woods and Water

Materials needed for *one* station

- Balance (triple beam, 0.1 g)
- *Block A* (3.7-cm cube) in plastic resealable bag (pine, maple, or other wood with a density $<1.0 \text{ g/cm}^3$)
- *Block B* (2.5-cm cube) (lignum vitae or other wood with a density $>1.0 \text{ g/cm}^3$, available in science stores or wood specialty stores)
- Handheld calculator (Four-function calculators are sufficient. Scientific calculators are permitted. Graphing calculators are **not** permitted.)
- Paper towels
- Black permanent marker
- Ruler (metric)
- Transparent plastic cup (5 oz) with water
- Plastic bag (resealable)
- Masking tape
- Labels

Preparation to be done prior to the test date:

1. The triple-beam balance must be mechanical and measure to the nearest 0.1 g. Do **not** use electronic balances. Do **not** place balances at locations near windows or doors if they will be open during testing. Air breezes may cause balance arm to oscillate while the student is measuring.
2. The ruler must have only metric units showing. All other units must be covered with tape or marked over with permanent marker. Be sure the tape does not get into the groove of the ruler. The 0-cm mark should be at the end of the ruler, not indented.
3. Use consecutive numbers to label the balance for each group. These numbers will indicate which students worked with that balance.
4. *Block A* should be about 3.7 cm on each side. *Block A*'s density should be about 0.7 g/cm^3 . Place *Block A* in a resealable plastic bag labeled "*Block A*" and "Do Not Open." Secure the bag with duct tape, masking tape, or a label so that it can **not** be opened.
5. *Block B* should be about 2.5 cm on each side. *Block B*'s density should be about 1.3 g/cm^3 . Replace any *Block Bs* that are not cubes with all sides approximately equal. (Lignum vitae may be purchased from a science store or wood specialty store.)
6. Label each face of the block with the letter "B." Use consecutive numbers to label the *Block B* samples for each group, e.g., B-1, B-2, etc. These numbers will indicate which group worked with that block.
7. Record the length of one side of the *Block B* samples on the Test Administrator's Record Sheet (Appendix III). Round length to the nearest 0.1 cm.
8. Once a *Block B* has been placed at each Station 3, find the mass of each block *using the balance at that station*. Record your results on the Test Administrator's Record Sheet. **Note:** The mass of *Block B* may be slightly greater at the end of the day. After the testing sessions are over, record the mass of *Block B* specimens again to be certain that the mass did not change appreciably. If this is the case, make notes on the Test Administrator's Record Sheet.
9. Calculate and record the volumes of the *Block B* samples on the Test Administrator's Record Sheet.
10. Calculate and record the density of the *Block B* samples on the Test Administrator's Record Sheet.
11. The plastic cup should be large enough for *Block B* to sink in about $\frac{1}{2}$ cup of water. It should be easy for the student to remove *Block B* from the cup.

12. **Note:** It is very important to test all Block B specimens to be certain that they sink when placed in the cup of water. **Block Bs that do not sink should be replaced with blocks that sink.**
13. Use masking tape to secure the Station Diagram in the lower left corner of the desk/table.
14. Place the equipment at the station so its location agrees with the Station Diagram on the next page.

Modifications: Any triple-beam balance that students are familiar with is acceptable as long as it is mechanical and able to measure to the nearest 0.1 g.

Safety: Routine laboratory safety procedures are required.

Station Diagram

Station 3: Woods and Water

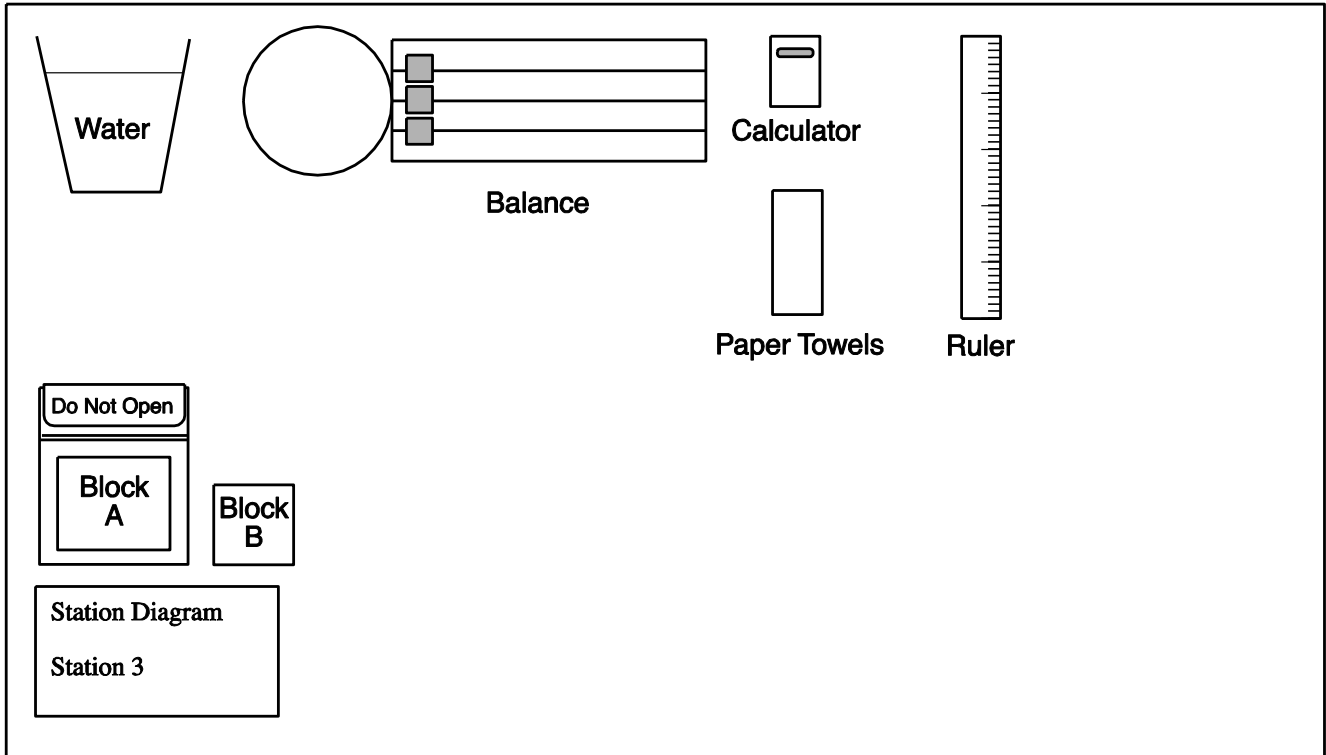

Detailed Directions for Administering the Performance Test

NOTE: Make sure that the Test Administrator’s Record Sheet (Appendix III) was completed when the stations were set up. This information is *very important*. It will be used to determine the range of correct answers by the teachers rating the test.

1. This assessment is a timed test. Students should be provided the opportunity to visit the restrooms prior to coming to the test room so that an unscheduled interruption does not occur during the testing period.
2. Teachers should tell students not to bring bookbags, coats, books, or such items to the testing room. These items will get in the way when students rotate among stations.
3. Just before the testing period begins, make sure that all microscope lamps are turned on (or microscope mirrors can get indirect light), the balances are at zero, and the calculators are at zero.
4. Quickly bring students into the testing room, first filling those stations farthest from the door. It does not matter which station students go to first because each student will eventually be doing all tasks. Instruct students *not* to touch the equipment and *not* to open the test booklet until they are instructed to do so.
5. If you must take attendance, save time by waiting until students are working at their stations.
6. Do *not* attempt to explain to students at the beginning of the test how to move among stations within the group. Present that information after they complete the first task and then again after the second task.
7. If students have questions during the test, you may give assistance for lost or broken equipment or safety issues. However, for most questions you should answer only, “Read it again,” “Sound out the word(s),” or “Do your best,” etc.
8. You must *not* give assistance to students on how to perform a procedure or acknowledge that the student is performing a correct *or* an incorrect procedure. This is not the time to be providing instruction. The purpose of this test is to determine what the student is able to do. Exceptions to this would be safety concerns or specific provisions in a student’s IEP for allowable testing accommodations.
9. Use a timing device, stopwatch, or clock with a sweep-second hand to provide accurate time splits of 10 minutes, 13 minutes, and 15 minutes. If you use a clock with a sweep-second hand, note the start time and splits on a piece of paper, the chalkboard, or the Test Administrator’s Record Sheet. See the chart below as an example. Be sure to collect a test booklet and pencil from *each* student before the students leave the testing room.

Time	Say:	First Station	Second Station	Third Station
Start Time	“You may begin work.”			
Start Time + 10 minutes	“You have 5 minutes left.”			
Start Time + 13 minutes	“You have 2 minutes left.”			
Start Time + 15 minutes	“Stop working.”			

Detailed Directions to Students Taking the Performance Test

Students will be anxious to get started. When students are at their first station and ready to work, quickly read aloud to the students the scripts that are in the boxes that follow. (Information in italics or in parentheses or information that is outside the boxes is information for you and your colleagues and is *not* to be read aloud.) Do *not* count this direction-reading stage as part of the time for completing the first task.

At the beginning of each test session, proctors must read the following statement to all students taking State tests:

You cannot have any communications device, including a cell phone, with you during this test or during any breaks (such as a restroom visit). Such devices include, but are not limited to:

- Cell phones
- Blackberry devices and other PDAs
- iPods and MP3 players
- iPads, tablets, and other eReaders
- Laptops, notebooks, or any other personal computing devices
- Cameras or other photographic equipment
- Headphones, headsets, or in-ear headphones such as earbuds
- Any other device capable of recording audio, photographic or video content, or capable of viewing or playing back such content

If you brought any of these items to the building today, and have not already stored it in your locker or turned it over to me or a school official, you must give it to me now. You may not keep your cell phone or any of these items with you, or near you, including in your pockets, backpack, desk, etc. If you keep a cell phone or any of these items with you, your exam will be invalidated and you will get no score. Is there anyone who needs to give me any of these items now?

[Proctor: repeat list of devices.]

This is your last opportunity to do so before the test begins.

Good morning (afternoon). Today, you will be taking a science skills test. I think you will enjoy it because you will be able to use science equipment to help you answer the questions on the test. Please listen carefully, follow my directions and the directions in your test booklet, and do your best work.

If you do not have a test booklet and a pencil at your station, raise your hand.
(short pause)

Print your name on the cover of your test booklet and put a check mark to indicate whether you are male or female. (pause) Write in the name of our school as I have it written on the chalkboard. (pause) Write your group number. I will tell you which group you are in. (Assign a number to the students in each group. This number can be determined by the number on Block B at Station 3 and Slide X at Station 1. For example, Group 4 should have Block B-4 and Slide X-4, etc.)

Keep this test booklet and pencil with you throughout the test. They will be collected at the end of the test.

Look at the cover of your test booklet. Let's read the test directions together. You read along silently while I read aloud.

This booklet contains science performance tasks located at three different stations: 1, 2, and 3. During this skills test, you will work at all three stations. You are already seated at one of these stations. Use the materials at each station to help you do the tasks.

At each station you will have 15 minutes to finish your work. Continue working until you see the word "**STOP**" at the bottom of the page or until the 15 minutes are up. If you have extra time, check your work, or wait quietly.

Do not help other students or ask others to help you. Everyone should work alone. There must be no talking between students during this test.

Read the description of each station carefully. Read carefully all of the directions in boxes. All of your answers must be recorded in this test booklet.

After you complete the tasks at each station, please leave the station the way it is shown on the Station Diagram. This diagram is located in the lower left corner of your station.

Do *not* try to explain at this time how the students will be moving from station to station. Leave that information until after they complete the first station (and then again after they complete the second station).

The directions that follow will be repeated three times during the testing session.

START HERE when reading directions for the second and third stations.

Say:

Look at the bottom left corner of your desk/table. The Station Diagram gives the number and the title of the station where you will be working. Open your booklet and find that station.

Pause and look around to be sure that everyone has found the correct place.

Look at the Station Diagram again. Check to see that you have all the equipment shown on the diagram and that the equipment is located where it should be. If you are missing equipment, raise your hand. (*pause*)

Resolve any equipment problems.

You may begin work. Read the description of the station at the top of the page. Read carefully all of the directions in boxes.

Begin timing the 15 minutes now.

Start a stopwatch or note the time on a clock with a sweep-second hand. Record the time on the chalkboard or on a sheet of paper. A sample chart is shown below.

Time	Say:	First Station	Second Station	Third Station
Start Time	"You may begin work."			
Start Time + 10 minutes	"You have 5 minutes left."			
Start Time + 13 minutes	"You have 2 minutes left."			
Start Time + 15 minutes	"Stop working."			

Remember that you can provide only limited assistance to the students. If students have questions during the test, you may give assistance only for lost or broken equipment, safety issues, or specific provisions in a student's IEP for allowable testing accommodations. For most student questions, you should answer, "Read it again," "Sound out the word(s)," or "Do your best," etc. You must *not* give assistance to students on how to perform a procedure or acknowledge that the student is performing a correct or an incorrect procedure. This is not the time to be providing instruction. The purpose of this test is to determine what the student is able to do.

For students at Station 1, Sorting Creatures: Be sure that students are recording their answers in the test booklet after performing the sort using the separate sorting chart.

For students at Station 2, Ramp and Golf Ball: While at this station, the students will raise their hands to return the golf ball. Do *not* give the students the Ping-Pong ball at this time. Wait until the students raise their hands a second time.

After 10 minutes, say:

You have 5 minutes left.

After 13 minutes, say:

You have 2 minutes left.

After 15 minutes, say:

Stop work.

Please put all the equipment back the way it is shown on the Station Diagram. Put the microscopes back to lowest power; put the balances back to zero; put the calculators back to zero. (*pause*)

Before the students rotate to the next station, check to be sure all equipment and materials are positioned as shown in the Station Diagrams. Be sure that the Ping-Pong balls have been collected and the golf balls have been returned to each Station 1 setup.

You are now going to move to your next station. I will show you how to do that. Be sure to take your test booklet and pencil with you.

Because stations have been arranged in groups, student movement can be kept to a minimum. Take one group and demonstrate for the whole class how students will move to the next station. Then let each group move one at a time and provide help when necessary. When all the students have moved, repeat the directions that start on page 37 until the testing session is completed.

When the students have completed ALL THREE STATIONS, say:

The science skills test is over. Thank you for being so attentive and cooperative during the test. Please wait quietly until all test materials are collected and you are dismissed.

Be sure to collect the test booklets and pencils from all students before they leave the room. Return all unused test booklets and materials to the secure location designated by your school administrator until such time as they are returned to the Department according to the instructions on page 14 of this manual.

Rating the Performance Test

NOTE: Teachers are **not** permitted to score their own student's answer papers.

The entire Performance Test will require rating by teachers. School administrators decide who can rate the Grade 8 Intermediate-Level Science Test after review of each teacher's certification and present and past teaching assignments. It is estimated that a team of three teachers should be able to rate the responses to all three stations for about 30 students in one hour. This scoring can be most quickly accomplished if one teacher rates all students' responses to Station 1 while another rates all students' responses to Station 2 and a third rates all students' responses to Station 3.

The Performance Test, Form A Rating Guide gives detailed directions for rating the Performance Test and specific criteria for rating each item. It is printed on yellow paper and is included in the shipment of test materials from the Department. In rating the students' test booklets, each rater should follow the procedures in the rating guide. The rating should be completed prior to June 11, the date when answer sheets must be submitted to the scanning centers.

Organizing the Rating Process

The following is a suggested procedure for managing the mechanics of the rating process.

1. Designate one person as the coordinator of the rating process. The coordinator may be appointed at either the building or the district level. He or she will be responsible for training and supervising raters and may rate some of the students' responses.
2. Set aside one room as a central rating room for collecting, sorting, circulating, and storing test booklets and for preparing and maintaining records.
3. Provide adequate time for rating during the school day.
4. Make sure each rater receives approximately the same number of student booklets, taking care to ensure that no teacher is assigned to rate the test booklets of his or her own students.
5. Provide a copy of the completed Test Administrator's Record Sheet (in Appendix III) to each rater.
6. At least two teachers, preferably three, should participate in rating the questions on the Performance Test. Each should be responsible for rating all of the questions for one station. No one teacher is to score all the open-ended questions in a student's test booklet.
7. Prior to the rating of the students' answers to the Performance Test, allow time to provide training for all raters (even if they have received prior training). If possible, select at random 10–15 student test booklets and duplicate them for use as a "warm-up" exercise with the raters for discussion of the questions, the criteria, and the rating of each item. During the training exercise, after three or four complete student test booklets have been rated, ask the raters to indicate, by a show of hands, how many credits they gave each answer. If there is some disagreement about the number of credits to be awarded for an answer, ask raters who gave different credits to an answer to explain their rating by citing specific criteria from the rating guide.
8. Raters should have a set of stations available to check the accuracy of questionable student answers by actually performing the task for which the answer was given.

Note: It is recommended that schools do *not* record the students' Performance Test scores on their scannable answer sheets until after the students have taken the Written Test and completed their portion of the answer sheet. This way, students will not be distracted by seeing their Performance Test scores on the answer sheets. This will also prevent students from altering those scores.

Finality of Teacher Scoring Committee's Scores

When the teacher scoring committee completes the scoring process, test scores must be considered final and must be entered onto students' permanent records. In addition, each rater must sign the *Test Scoring Certificate* attesting that he or she faithfully observed the regulations for scoring the tests. The principal must also sign this certificate to attest that the rules and regulations for scoring were fully and faithfully observed.

Principals and other administrative staff in a school or district do not have the authority to set aside the scores arrived at by the teacher scoring committee and rescore student test papers or to change any scores assigned through the procedures described in this manual and in the scoring materials provided by the Department. Any principal or administrator found to have done so, except in the circumstances described below, will be in violation of Department policy regarding the scoring of this test. Teachers and administrators who violate Department policy with respect to scoring State tests may be subject to disciplinary action in accordance with Sections 3020 and 3020-a of Education Law or to action against their certification pursuant to Part 83 of the Regulations of the Commissioner of Education.

On rare occasions, an administrator may learn that an isolated error had occurred in arriving at a final test score for a student or in recording the student's score in the permanent records. For example, the final test score may have been based on an incorrect summing of the student's raw scores for parts of the test or from a misreading of the conversion chart. When such errors involve the final scores on any State test of no more than 5% of the school's test takers for that test or 5 students, whichever is greater, and when such errors are detected within four months of the test date, the superintendent of a public school district or the chief administrative officer of a nonpublic or charter school may arrange for the corrected score to be recorded in the student's permanent record. However, in all such occurrences, the superintendent or chief administrative officer must advise OSA in writing that the student's score has been corrected. The written notification to the Department must be signed by the superintendent or chief administrative officer and must include the names of the students whose scores have been corrected, the name of the test, the students' original and corrected scores, and a brief explanation of the nature of the scoring error which was corrected.

If an administrator has substantial reason to believe that the teacher scoring committee has failed to accurately score more than 5% or five student answer papers, whichever is greater, on any test or when such errors are detected more than four months after the test date, the administrator must first obtain permission in writing from OSA before arranging for or permitting a rescoring of student papers. The written request to OSA must come from the superintendent of a public school district or the chief administrative officer of a nonpublic or charter school and must include the test title, date of administration, and number of students whose papers would be subject to such rescoring. This request must also include a statement explaining why the administrator believes that the teacher scoring committee failed to score appropriately and, thus, why he or she believes rescoring the test papers is necessary. As part of this submission, the school administrator must make clear his or her understanding that such extraordinary re-rating may be carried out only by a full committee of teachers constituted in accordance with the scoring guidelines presented in this manual and fully utilizing the scoring materials for this test provided by the Department.

The Department sometimes finds it necessary to notify schools of a revision to the scoring key and rating guide for a test. Should this occur after the scoring committee has completed its work, the principal is authorized to have appropriate members of the scoring committee review students' responses only to the specific question(s) referenced in the notification and to adjust students' final test scores when appropriate. Only in such circumstances is the school not required to notify or obtain approval from the Department to correct students' final test scores.

Reporting Irregularities and/or Misadministrations

Pursuant to Section 102.3 of the Regulations of the Commissioner of Education, “Building principals are responsible for administering department examinations and maintaining the integrity of examination content and programs, in accordance with directions and procedures established by the commissioner.” Accordingly, the building principal is responsible for all aspects of the school’s test administration and must take appropriate measures both to prevent, as much as possible, and to investigate all security breaches and irregularities associated with the administration and scoring of the test. In addition, the principal must report the following testing irregularities and misconduct by students, in writing on school letterhead and signed by the principal, to OSA via fax to 518-474-1989 or by e-mail to emscassessinfo@nysed.gov :

- All student infractions of the Department’s policy prohibiting the possession or use of cell phones and other communications devices during State tests.
- All confirmed cases of students cheating.
- All interruptions of test sessions including those caused by power outages or fire alarms.
- All instances in which a State test is administered without Department authorization on a date outside the published statewide administration or makeup schedule.
- All instances in which scorers do not rate State tests in accordance with the scoring materials provided by the Department.
- All cases in which student test books or answer sheets are lost prior to either the scoring of the tests or submission of the answer sheets to the RIC or large-city scanning center.
- All instances of school officials or staff members providing students with other nonstandard test administrations, unrelated to cheating.

The report must include:

- The school’s BEDS Code,
- The name and grade level of the test,
- A brief description of the incident,
- The number of students affected, and
- The New York State Student Identification System (NYSSIS) ID numbers of affected students.

Mandatory Reporting of Testing Improprieties by Adults

The Department’s Test Security Unit (TSU) handles all reports of testing improprieties by adults involved in the administration and scoring of State tests. School officials and personnel are required to report any incident of testing misconduct by an educator or other adult involved in testing. Reports should be made via the TSU web site at <http://www.highered.nysed.gov/tsei/> by submitting the incident report form located on the main page under “Report Educator Test Fraud.”

No adverse action, including dismissal and any disciplinary action, may be taken against an employee who files a mandatory report of testing misconduct, because the employee filed a report. Anyone who takes such unwarranted adverse action against another employee may face disciplinary action by the Department.

Examples of Improper Testing Conduct Reported to the TSU

- All suspected or confirmed cases of a school official or staff member giving aid or impromptu lessons on specific test content to students immediately before or during a State test or altering student responses on a test paper.

- All cases in which a school official does not adhere to the Department policy concerning the finality of test scores as determined by the teacher scoring committees. This policy is explained on page 40 of this manual under the heading “Finality of Teacher Scoring Committee’s Scores.”
- All instances of an administrator or teacher instructing another administrator or teacher to alter or interfere with a student’s test score.

Coding of Invalid Tests

Any breaches or irregularities described on the preceding page, except interruptions caused by power outages or alarms, may be determined by the school or by the Department to invalidate a student’s test results. In cases where a student’s test has been invalidated the principal must:

1. Darken the circle on the affected student’s answer sheet denoting “administrative error.”
2. Notify the RIC or large-city scanning center of the administrative error. In order to expedite accurate reporting, provide the BEDS Code, School Name, Subject, Grade, and NYSSIS ID number.
3. In the SIRS, in the *Assessment Standard Achieved Code* field, code the student’s test result as “administrative error with *Standard Achieved Code of 97.*”
4. If a student’s test is deemed to be an administrative error **after** the student’s answer sheet has been scanned, the scanning center must be contacted and asked to submit a request to the Department’s Office of Information and Reporting Services for permission to override the score to an Assessment Standard Achieved Code of “97” indicating administrative error.

On the verification reports, a student for whom an administrative error occurred will not receive a valid score and will appear as “not tested.”

Circumstances that Should Not Be Reported as Administrative Error

If a scanning center sends an answer sheet that contains inaccurate demographic data, do not darken the circle denoting an administrative error on the answer sheet. Instead, communicate the problem to the scanning center, go back into the student management system (SMS), correct the demographic data, and reload it into SIRS. If the student uses a blank/extra answer sheet in place of the preprinted answer sheet with incorrect demographic data, do not code the original answer sheet as an administrative error. Instead, communicate the problem to the scanning center but do not submit the incorrect answer sheet for processing.

If a scanning center sends an answer sheet to the school for a student who is no longer enrolled in that school, do not code the answer sheet as an administrative error. Instead, communicate the problem to the scanning center and go back into the SMS to correct the enrollment record to reflect the ending enrollment and reload it into the SIRS.

Students originally reported with an incorrect grade level should not be reported as administrative error as long as the student is administered the correct grade level test using a blank answer sheet for the appropriate grade level test. Do not submit the incorrect answer sheet to the scanning center. Instead, communicate the problem to the scanning center, correct the student information in the SMS, and reload the updated demographic information into SIRS.

Schools should communicate any concerns or questions to the RIC or large-city scanning center prior to, or at the time of, delivery of the answer sheets.

Appendix I

Materials Needed to Administer the Performance Test, Form A

The Department will provide the test booklets, rating guides, and other printed administration materials. Schools are responsible for obtaining the materials needed for the performance tasks. Schools can either prepare these materials or purchase the materials in a complete kit from one of several vendors (see Appendix VIII). Schools might want to contact the vendor that has supplied them with kits in the past. A list of materials that will be needed for *one* setup for each of the three stations appears below.

Schools will need to provide microscopes, triple-beam balances, and handheld calculators.

Station 1: Sorting Creatures

Materials for *one* station

- Black permanent marker
- Collection of six specific plastic creatures
- Index card (3" × 5", unlined)
- Masking tape
- Microscope with an eyepiece of 10× and at least two lenses (providing total magnification of about 40× and 100×)
- Slide A—slide of grid with 1-mm squares (graph paper)
- Slide X—slide of microscopic specimen: (recommend *Drosophila*—**must clearly show** six legs)
- Sorting Chart (8½" × 14"), preferably laminated

Station 2: Ramp and Golf Ball

Materials for *one* station:

- Black permanent marker
- Carpet tape or duct tape
- 5-gram mass or 25-cent coin
- Golf ball
- Masking tape
- Resealable plastic bag
- Ping-Pong ball
- Place mat with measuring strip
- Round plastic container with hole
- Ruler with groove (metric)
- Support Block(s)
- Labels

Station 3: Woods and Water

Materials for *one* station:

- Balance (triple beam, 0.1 g)
- Block A (3.7-cm cube) in plastic resealable bag (pine, maple, or other wood with a density <1.0 g/cm³)
- Block B (2.5-cm cube) (lignum vitae or other wood with a density >1.0 g/cm³, available in science stores or wood specialty stores)
- Handheld calculator (Four-function calculators are sufficient. Scientific calculators are permitted. Graphing calculators are **not** permitted.)
- Paper towels
- Black permanent marker
- Ruler (metric)
- Transparent plastic cup (5 oz) with water
- Plastic bag (resealable)
- Masking tape
- Labels

Appendix II

Comparison of Possible Performance Test Sites

SITE: CLASSROOM	
<i>Advantages</i>	<i>Disadvantages</i>
<ul style="list-style-type: none"> • Ease of station preparation • Furniture already at site • Good station-to-station movement • Only classroom teacher and students will be disrupted • Secure location 	<ul style="list-style-type: none"> • Need to relocate the teacher and students whose room is being used for the duration of the testing • Individual student desks may be too narrow for the ball and ramp station unless they are at least 36 inches wide
SITE: LIBRARY	
<i>Advantages</i>	<i>Disadvantages</i>
<ul style="list-style-type: none"> • Large space • Tables and/or carrels and chairs at site • Secure location 	<ul style="list-style-type: none"> • May disrupt more teachers and students than classroom site • Library unavailable for other uses during testing
SITE: CAFETERIA	
<i>Advantages</i>	<i>Disadvantages</i>
<ul style="list-style-type: none"> • Large space • Tables and chairs at site 	<ul style="list-style-type: none"> • May disrupt a large number of teachers and students • Unavailable for other uses during testing • Poor security • Breakfast/lunch program may interrupt the testing • Poor acoustics and high noise levels • May need to disassemble and reassemble stations before and after lunch
SITE: SCIENCE ROOM	
<i>Advantages</i>	<i>Disadvantages</i>
<ul style="list-style-type: none"> • Large space • Tables and/or carrels and chairs at site • Secure location • Science materials on site • Counters with electrical outlets for microscopes 	<ul style="list-style-type: none"> • May disrupt more teachers and students than classroom site
SITE: GYMNASIUM	
<i>Advantages</i>	<i>Disadvantages</i>
<ul style="list-style-type: none"> • Large space 	<ul style="list-style-type: none"> • May disrupt large numbers of teachers and students • Need to move tables or desks and chairs into space • Poor security • Poor acoustics • Not a familiar testing site for students • May need to disassemble and reassemble stations to accommodate physical education classes
SITE: HOME AND CAREERS CLASSROOM	
<i>Advantages</i>	<i>Disadvantages</i>
<ul style="list-style-type: none"> • Large space • Counters with electrical outlets for microscopes 	<ul style="list-style-type: none"> • May disrupt more teachers and students than classroom site

Appendix III
Test Administrator's Record Sheet
Grade 8 Intermediate-Level Science
Performance Test, Form A

This record sheet should be completed by the person(s) administering the Performance Test. At the conclusion of the test administration, return this completed record sheet with the student test booklets to the person in charge of the testing program for the school. **The information on this record sheet will be needed to accurately score the tests.** Be certain to fill in both sides of this sheet completely.

Test Administrator(s): _____ Date: _____

School Name: _____ School District: _____

Station 1: Sorting Creatures
Microscope Power and Data for *Drosophila* on Slide X

Group	Lowest Power Available on Microscope	Field of View Diameter (to nearest 0.5 mm)	Acceptable Range for Field of View (± 0.5 mm)	Length of <i>Drosophila</i> (to nearest 0.5 mm)	Acceptable Range for Length (± 0.5 mm)	Number of Legs That Are Clearly Visible	Acceptable Range for Number of Legs (± 1)
1							
2							
3							
4							
5							
6							
7							
8							
9							
10							
11							
12							

Station 3: Woods and Water
Mass, Length, and Volume for Block B

Group	Mass (to nearest 0.1 g)	Acceptable Range (± 1.0 g)	Length of One Side (to nearest 0.1 cm)	Acceptable Range (± 0.1 cm)	Volume (to nearest 0.1 cm ³)	Acceptable Range (± 3.0 cm ³)	Density (to the nearest 0.1 g/cm ³)	Does Block B sink when placed in water?*
1								
2								
3								
4								
5								
6								
7								
8								
9								
10								
11								
12								

Station 3 Note: All Block B specimens must have a density of greater than 1.0 and **must** sink when placed in water.

Note: If any materials used during the test administration were different from those specified in Appendix I, or if the administration directions were not followed exactly as written, note these differences below. Be specific. These variations can be important when scoring the students' test booklets.

Appendix IV

Station 1—Sorting Chart (to be reproduced on 8½" × 14" paper and laminated)

Sorting Chart

Place all the creatures here. Move the creatures in and around the appropriate boxes as you answer the questions.

Question: Does this creature have more than six legs?

1

Yes

Question: (Record your question in the test booklet.)

2

No

Question: (Record your question in the test booklet.)

3

Yes

4

No

5

Yes

6

No

Appendix V

Station 2—Ramp Place Mat (to be reproduced on 11" × 17" paper and laminated)

Ramp Place mat

for actual size-
increase to 155%
and print on
11" x 17" paper

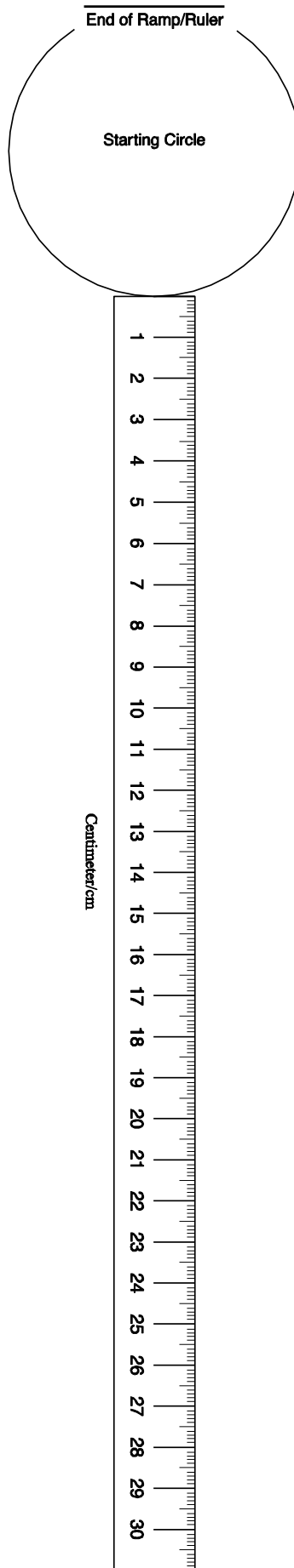

Appendix VI

Test Storage Certificate

Deputy and Proctor Certificate

Test Scoring Certificate

TEST STORAGE CERTIFICATE

Grade 8 Intermediate-Level Science Test

School Name: _____

Performance Test

Test Date: _____
(Month/Year)

Written Test

I, the undersigned principal of the school named above, do hereby declare that each of the security procedures listed below was fully and faithfully observed for the current administration of the 2015 Grade 8 Intermediate-Level Science Test.

1. The shrink-wrapped packages of secure test materials were stored in the secure location indicated on the Test Storage Plan submitted to the Department for the above test date period.
2. The secure location was maintained under strict security conditions.
3. An inventory of the test materials was conducted as soon after delivery as was practical. The Department was notified in writing if any of the packages of secure test materials were not properly shrink-wrapped when received. The shrink-wrapped packages of secure test materials were replaced inside the secure location immediately after the inventory was completed.
4. The shrink-wrapped packages of secure materials were not removed from the secure location, except for the inventory of test materials shipped to the school, until the day on which the test was scheduled to be administered.
5. The shrink-wrapped packages of secure test materials were not opened until the day on which the test was scheduled to be administered.
6. Following testing, test booklets and answer sheets were collected and stored in a secure location.

Name of Principal (print or type): _____

Signature of Principal: _____ Date: _____ / _____ / _____

After completion, retain in school files for one year.

DEPUTY AND PROCTOR CERTIFICATE
Grade 8 Intermediate-Level Science Test

School Name: _____ Performance Test

Test Date: _____ Written Test
 (Month/Year)

We, the undersigned deputies and proctors who assisted in the administration of the 2015 Grade 8 Intermediate-Level Science Test, hereby declare our belief in the correctness of the following:

The rules and regulations for administering the test were fully and faithfully observed, and in particular:

1. The rules for administering the test were read to or read by each person who assisted in administering the test.
2. The test was administered within the prescribed dates.
3. The secure test materials were kept in the shrink-wrapped packages until the administration date.
4. The students were given appropriate instructions and orientation before beginning the test.
5. The students were so seated as to prevent collusion.
6. Adequate supervision was maintained throughout the administration of the test.
7. The answer papers were collected from the students immediately at the close of the test.
8. All test books and answer sheets for the test were collected and returned to the principal for storage in a secure location after testing.

	Print Name	Signature	Test Proctored	Test Room
1				
2				
3				
4				
5				
6				
7				
8				
9				
10				

(Make additional copies as necessary.)
After completion, retain in school files for one year.

TEST SCORING CERTIFICATE

Grade 8 Intermediate-Level Science Test

School Name: _____ Performance Test Written Test
City or Town: _____ Test Date: _____
(Month/Year)

As one of the undersigned raters who participated in the scoring of the Grade 8 Intermediate-Level Science Test (**each** participating rater **must** sign below), I hereby declare our belief in the correctness of the following statement:

The rules and guidance materials for rating the test were fully and faithfully observed, and in particular:

1. As a rater, I was trained using the procedures and materials described in the Grade 8 Intermediate-Level Science Test Manual for Administrators and Teachers, the Rating Guide for the Written Test Part II, and the Rating Guide for the Performance Test.
2. The rating committee, of which I was a member, included the required minimum number of raters as specified in the Grade 8 Intermediate-Level Science Test Manual for Administrators and Teachers.
3. Test questions were assigned to me for rating according to the procedures described in the Grade 8 Intermediate-Level Science Test Manual for Administrators and Teachers.
4. As a rater, I did not rate any of my own students' responses.
5. Where required, my name or initials were clearly recorded on the answer paper or scoring record.
6. The answer papers and test booklets were safeguarded while scoring was occurring.

- | | |
|-----------|-----------|
| 1. _____ | 11. _____ |
| 2. _____ | 12. _____ |
| 3. _____ | 13. _____ |
| 4. _____ | 14. _____ |
| 5. _____ | 15. _____ |
| 6. _____ | 16. _____ |
| 7. _____ | 17. _____ |
| 8. _____ | 18. _____ |
| 9. _____ | 19. _____ |
| 10. _____ | 20. _____ |

As principal, I attest that the rules and regulations for scoring, as listed above, were fully and faithfully observed.

Principal: _____ Date: ____ / ____ / ____

After completion, retain in school files for one year.

Appendix VII

Information on Ungraded Students

Students who are graded must take the State test for the grade level in which they are enrolled. The chart below is to be used solely to ascertain the appropriate grade-level tests to administer to ungraded students with disabilities.

Age Ranges for Testing on the NYSAA and General Assessments for Ungraded Students with Disabilities at the Elementary and Middle Levels in the 2014–2015 School Year

Assessment	Birth Date	Reaches Age Given Between September 1, 2014 and August 31, 2015
Grade 3 English Language Arts, Mathematics	September 1, 2005–August 31, 2006	9
Grade 4 English Language Arts, Mathematics, Science	September 1, 2004–August 31, 2005	10
Grade 5 English Language Arts, Mathematics	September 1, 2003–August 31, 2004	11
Grade 6 English Language Arts, Mathematics	September 1, 2002–August 31, 2003	12
Grade 7 English Language Arts, Mathematics	September 1, 2001–August 31, 2002	13
Grade 8 English Language Arts, Mathematics, Science	September 1, 2000–August 31, 2001	14

Appendix VIII

Suppliers for Grade 8 Intermediate-Level Science Performance Test Kits

The Grade 8 Intermediate-Level Performance Test, Form A, will be given during the designated administration period. This is the same performance test that has been administered since 2001. A new kit will not be needed. The suppliers below can be contacted if replacement materials or additional kits are needed.

Kathy Arminio, Director
Elementary Science Program
Monroe #2 - Orleans BOCES
38 Turner Drive
Spencerport, NY 14559
585-352-1140
800-832-8011
E-mail: karminio@monroe2boces.org
Web site: www.espsciencetime.org

Frey Scientific
80 Northwest Boulevard
Nashua, NH 03063

Mr. Rod Gusman, Regional Sales Manager
(Southern NY, New York City and Long Island)
Frey Scientific Customer Service: 800-225-3739
Local Office: 908-578-5901
E-mail: rod.gusman@schoolspecialty.com

Dr. Charlene Jordan
Director of Professional Development
and Instructional Support
Rockland BOCES
65 Parrott Road
West Nyack, NY 10994
Office Phone: 845- 627-4725
Office Fax: 845-623-3343
E-mail: cjordan@rboces.org

Mr. Paul Glodek, Regional Sales Manager
(All other areas of New York State)
Frey Scientific Customer Service: 800-225-3739
Local Office: 215-439-5503
E-mail: paul.glodek@schoolspecialty.com

Mr. Geof Smith
Ward's Science
5100 West Henrietta Road
PO Box 92912
Rochester, NY 14692-9012
800-962-2660 x309416
Office Phone: 585-321-9416
Cell: 585-260-7266
E-mail: geof.smith@vwr.com
Web site: <http://www.wardsci.com>

Appendix IX

Performance Levels Chart

The chart on the next page defines the four performance levels for this test. The state-designated level of performance for this test is a final score of 65 or higher (levels 3 and 4). Students scoring below 65 (levels 1 and 2) must be provided with academic intervention services or Response to Intervention according to Section 100.2(ee) of the Regulations of the Commissioner of Education. The chart provides the final score range and a brief description of student performance for each level.

Performance Levels
Grade 8 Intermediate-Level Science Test

Level	Final Test Score Range	Description of Student Performance
4	85 – 100	<p style="text-align: center;">Meeting the Standards with Distinction</p> <ul style="list-style-type: none"> • The student demonstrates superior understanding of the intermediate-level science content and concepts for each of the learning standards and key ideas assessed. • The student demonstrates superior intermediate-level science skills related to each of the learning standards and key ideas assessed. • The student demonstrates superior understanding of the intermediate-level science content, concepts, and skills required for a secondary academic environment.
3	65 – 84	<p style="text-align: center;">Meeting the Standards</p> <ul style="list-style-type: none"> • The student demonstrates understanding of the intermediate-level science content and concepts for each of the learning standards and key ideas assessed. • The student demonstrates the science skills required for intermediate-level achievement in each of the learning standards and key ideas assessed. • The student demonstrates understanding of the intermediate-level science content, concepts, and skills required for a secondary academic environment.
2	44 – 64	<p style="text-align: center;">Not Fully Meeting the Standards</p> <ul style="list-style-type: none"> • The student demonstrates only minimal proficiency in intermediate-level science content and concepts in most of the learning standards and key ideas assessed. • The student demonstrates only minimal proficiency in the skills required for intermediate-level achievement in most of the learning standards and key ideas assessed. • The student demonstrates marginal understanding of the science content, concepts, and skills required for a secondary academic environment.
1	0 – 43	<p style="text-align: center;">Not Meeting the Standards</p> <ul style="list-style-type: none"> • The student is unable to demonstrate understanding of the intermediate-level science content and concepts in most of the learning standards and key ideas assessed. • The student is unable to demonstrate the science skills required for intermediate-level achievement in most of the learning standards and key ideas assessed. • The student is unable to demonstrate evidence of the basic science knowledge and skills required for a secondary academic environment.



**New York State
Grade 8
Intermediate-Level
Science Test
Manual for Administrators and Teachers
2015 Written Test
Performance Test, Form A**