

## DOCUMENT RESUME

ED 463 146

SE 065 719

AUTHOR Ballone, Lena M.; Czerniak, Charlene M.  
TITLE Teachers' Beliefs about Accommodating Students' Learning Styles in Science Classes.  
ISSN ISSN-1087-3430  
PUB DATE 2001-12-00  
NOTE 44p.  
PUB TYPE Journal Articles (080)  
JOURNAL CIT Electronic Journal of Science Education; v6 n2 Dec 2001  
EDRS PRICE MF01/PC02 Plus Postage.  
DESCRIPTORS Cognitive Style; Higher Education; \*Science Curriculum; \*Science Instruction; \*Science Teachers; \*Teacher Attitudes; \*Teaching Methods

## ABSTRACT

Learning styles is a common strand found throughout recent science education reform recommendations. The objective of this study was to examine the influences of teacher beliefs regarding their intent to implement a variety of instructional strategies to meet the needs of different learning styles in the science classroom. Ajzen's (1985) Theory of Planned Behavior was used to investigate the influence of the primary constructs' (attitude toward the behavior (AB), subjective norm (SN), and perceived behavioral control (PBC) on intent to engage in the targeted behavior. Differences between various teacher populations for the three primary constructs and intent also were examined. Survey research methods were employed to obtain data (n=109 Ohio teachers, randomly selected). Results were statistically analyzed using multiple regression, correlations, descriptive statistics, reliability, ANOVAS, and Scheffe post hoc techniques. Results indicated that attitude toward behavior and subjective norm influenced teachers' intent to implement variety of instructional strategies to meet the needs of different learning styles. Attitude toward behavior was the greatest influence. It was concluded that teacher belief constructs should be considered carefully when planning teacher development programs in order to successfully implement science reform recommendations. (Contains 53 references.) (Author/MM)

Reproductions supplied by EDRS are the best that can be made  
from the original document.

PERMISSION TO REPRODUCE AND DISSEMINATE THIS MATERIAL HAS BEEN GRANTED BY

*L. Ballone*

TO THE EDUCATIONAL RESOURCES INFORMATION CENTER (ERIC)

1

U.S. DEPARTMENT OF EDUCATION  
Office of Educational Research and Improvement  
EDUCATIONAL RESOURCES INFORMATION CENTER (ERIC)

This document has been reproduced as received from the person or organization originating it.

Minor changes have been made to improve reproduction quality.

Points of view or opinions stated in this document do not necessarily represent official OERI position or policy.

### Teachers' Beliefs About Accommodating Students' Learning Styles In Science Classes

Lena M. Ballone  
Bowling Green State University, Bowling Green, OH 43402

Charlene M. Czerniak  
The University of Toledo, Toledo, OH 43606

SS05719

## ABSTRACT

Learning styles is a common strand found throughout recent science education reform recommendations. The objective of this study was to examine the influences of teacher beliefs regarding their intent to implement a variety of instructional strategies to meet the needs of different learning styles in the science classroom. Ajzen's (1985) Theory of Planned Behavior was used to investigate the influence of the primary constructs (attitude toward the behavior (AB), subjective norm (SN), and perceived behavioral control (PBC) on intent to engage in the targeted behavior. Differences between various teacher populations for the three primary constructs and intent also were examined. Survey research methods were employed to obtain data (n=109 Ohio teachers, randomly selected). Results were statistically analyzed using multiple regression, correlations, descriptive statistics, reliability, ANOVAS, and Sheffe post hoc techniques. Results indicated that attitude toward behavior and subjective norm influenced teachers' intent to implement variety of instructional strategies to meet the needs of different learning styles. Attitude toward behavior was the greatest influence. It was concluded that teacher belief constructs should be considered carefully when planning teacher development programs in order to successfully implement science reform recommendations.

## INTRODUCTION

Science education in the United States is once again in the midst of another surge of science education reform projects. Today's science reform efforts focus on the belief that all students are capable of learning science and therefore must be granted the necessary opportunities and conditions for optimal science learning. Two major national policy efforts are paving the way in the reconstruction of science education. These projects include Project 2061 (Rutherford & Ahlgren, 1990) and the National Science Education Standards (NRC, 1996). Both projects have impacted and brought forth statewide initiatives for science education (see ODE, 1994). Although the efforts in each of these projects are distinct, they possess many similarities and common themes. Researchers at BSCS (1994) identified common themes from national science education reform documents. These themes include: cooperative learning, thematic approach, constructivism, classroom management, assessment and evaluation, equity, science technology-society, educational technology, and learning styles.

This particular study focuses on the learning style strand identified by BSCS as being found in many science education reform reports. The National Science Education Standards (NRC, 1996) demonstrate as one of its main principles the notion that science is for all students and that curriculum content must be designed to meet the interests, abilities, experiences, understandings, and knowledge of students. Accepting diversity in learning styles is accepting the belief that all students can learn (Guild, 1994).

During the last decade, considerable time and effort has gone into developing and implementing these suggested science education reforms. However, many of these reform reports have ignored beliefs of classroom teachers. Studies warn of the inherent problems associated with ignoring classroom teachers' beliefs about reform. Research on beliefs indicates that teachers are crucial change agents leading the way to education reform and that teacher beliefs are precursors to change (Ajzen & Fishbein, 1980; Crawley & Koballa, 1992; Pajares, 1992; Battista, 1994). Because beliefs can impact teacher behavior, this study focuses on teacher beliefs regarding the learning style strand found in current reform documents.

## LITERATURE REVIEW

### National Reforms

Project 2061: (Science for All Americans) (Rutherford & Ahlgren, 1990) was developed by The American Association for the Advancement of Science (AAAS). The primary theme is that it is imperative for schools to teach more effectively in order to foster scientific literacy, rather than cover more content. Science for all Americans is based on the conviction that a scientifically literate person is one who is cognizant that science, mathematics, and technology are human enterprises dependent upon one another. Primarily written by researchers, teachers, scientists, and leaders from business and industry, the report set goals which include, 1) defining scientific literacy, 2) establishing benchmarks for science education, and 3) creating a method to guide teacher education and material design.

Although Science for All Americans emphasizes what students should learn, it also examines how science should be taught, making the claim that effective teachers consider the material to be learned, the background of the students, and the conditions under which teaching and learning take place. Example recommendations suggest that science teaching should: engage students actively, start with questions about nature, incorporate cooperative learning, and de-emphasize the rote memorization of facts. Science for All Americans (Rutherford & Ahlgren, 1990) also stresses the connection between teacher's attitudes and student's beliefs about science.

Another current science reform report, similar in effort and in themes to Project 2061, is the National Science Education Standards (The Standards) (NRS, 1996). The Standards are guided by the following beliefs: 1) science is for all students, 2) science learning is an active process, 3) science teaching should reflect intellectual and cultural traditions of contemporary science and, 4) science education is part of systemic education reform. The criteria in The Standards demonstrate the quality of what students should be able to do and know; the quality of science teaching, programs, and assessment practices; and policies.

The Standards confront what teachers of science at all grade levels should know and be able to do. These suggestions relate to the pedagogical actions of teachers which correlate to student learning styles and needs. The Standards reveal the following: 1) science teachers should design active learning environments, 2) the activities and content that the teacher chooses affects the knowledge, abilities, understandings, and attitudes that students develop and, 3) student learning

is actively constructed by social and individual processes. The recommendations found in The Standards supports a strong commitment to meeting the needs of student learning styles by incorporating a variety of instructional strategies.

### Learning Styles

Learning style is defined as the manner in which students of all ages are affected by sociological needs, immediate environment, physical characteristics, emotionality and psychological inclinations (Carbo, Dunn & Dunn, 1986). Learning styles, as defined by Pat Guild (1994), are conceptual, behavioral, cognitive, and affective patterns that are displayed over time and task. The concept of learning style is not a new focus in education, and research related to learning styles has flourished in the past two decades. The work on learning style has century old roots in Hippocrates' discussion of temperaments (Guild, 1994), and a plethora of models such as cognitive style mapping, learning style assessments, conceptual level theory, and brain behavior analysis have evolved (Wheeler, 1988). Gregoric (1979) asserts that one's learning style is made up of distinct behaviors that serve as indicators of how one learns and adapts to the environment. He continues to note, "It gives us a clue as to how a person's mind operates" (p. 234).

Historically, psychologists have been interested in differences between individuals and have described patterns in people's personalities. Becoming familiar with differences in style provides in depth communication and understanding of the interests and needs of a diverse school population. The acceptance of diversity of style creates an atmosphere that encourages a student to reach his or her full potential (Guild & Garger, 1985). Similarly, this philosophy that all students should reach their full potential is mirrored in the major science education reform reports.

The phrase "psychological type," popularized by Carl Jung's work, is descriptive of what is called learning style or cognitive style (Guild & Garger, 1985). As Jung developed a psychological topology, it characterized the major styles that are used to understand occurrences in life (Bargar & Hoover, 1984). Jung described differences among people as being either introverted or extroverted. It has been revealed that the functions of thinking, intuition, sensation, and feeling will be expressed in different ways by those with introverted preferences than by those with extroverted preferences (Guild & Garger, 1985). Each of these descriptors demonstrates ones' preferred learning or cognitive style (Bargar & Hoover, 1984).

A variety of researchers have attributed learning style differences to modality strengths. Modalities refer to the sensory channel by which we receive and give messages. The visual, auditory, and kinesthetic modalities are recognized as significant sensory channels for education (Guild & Garger, 1985).

Anthony Gregoric's work with learning styles suggests that styles emerge from innate predispositions and that people learn both through concrete experience and abstraction. Some minds prefer abstraction while others operate most effectively through concrete circumstances. The two varieties of perception encompass opposite ends of a continuum: Abstract—Concrete. The human mind also exhibits the ability to order information in two manners that are at opposite ends of the continuum: Sequential-Random. As noted in Guild and Garger (1985), "While every person is able to use both sequential and random ordering, we each have a tendency to prefer and to operate most frequently and most successfully with one kind of ordering" (p. 38). The combination of perception and ordering yields four different styles: 1) Concrete-Sequential, 2) Abstract-Sequential, 3) Concrete-Random, and 4) Abstract-Random. The Gregoric Style Delineator, which identifies these four styles, is a self analysis tool to assess one's perceptual and ordering abilities (Guild & Garger, 1985).

Utilizing the concept of four different learning styles, Kolb's model of experiential learning determines one's learning style and describes learning as a four-step process. Learners initially have a concrete experience that yields reflective observations. These observations allow abstract conceptualizations which yield generalizations or principles. Using these generalizations, a learner can become engaged in active experimentation that results in a higher-order concrete experience. Through Kolb's inventory of learning styles, four types emerge: divergers, assimilators, convergers, and accommodators. Divergers grasp a learning experience by concrete methods and transform it through reflective observation. Assimilators grasp the experience through abstract conceptualization and transform it through reflective observations. The convergers gain experience by abstract conceptualization and transform it through active experimentation. Accommodators acquire the learning experience by concrete methods and transform it through active experimentation (Claxton & Murrell, 1987).

Focusing on Kolb's work and incorporating right/left brain hemispheric functioning, Bernice McCarthy's 4MAT System provides four learning styles (Wheeler, 1988). The System's four quadrants represent the variety of ways a student can approach a learning situation, process

information, and transform learned information. The 4MAT System permits students to fall on a continuum from Active Experimentation to Reflective Observation. Type One learners are primarily brainstormers with the need to become personally involved in class. They perceive information in a concrete manner and reflectively process it. A favored question for this learner is “WHY?” It is essential that science teachers illustrate and provide reasons for phenomena. Type Two learners are analytical, receive information abstractly and reflectively process it. Typically, they are interested in the question, “WHAT?” They are interested in details and facts that lead to greater conceptual understanding. Science teachers who provide this group with facts meet the needs of the learners. Type Three learners process information actively after they perceive it in an abstract way. A primary question for this type of learner is “HOW?” They are “doers” who are interested in procedures. A strong preference is demonstrated to “try things out for themselves” which leads to conceptual understanding. A science teacher will address the needs of this learner by permitting the student to engage in activities and explore ideas. Finally, Type Four learners are considered risk-takers, as they perceive information concretely and actively process it. An essential question that they prefer to address is “IF?” They are interested in self-discovery and have a desire to learn by trial and error. A teacher is successful with this learner by providing an environment that encourages the students to teach themselves and others through self-discovery (Wheeler, 1988).

Howard Gardner emphasizes that human beings view the world in seven ways in which he refers to as seven human intelligences. In The Unschooled Mind, he declares, that “Students possess different kinds of minds and therefore learn, remember, perform, and understand in different ways.” Gardner adds that individuals can view the world through language, musical thinking, spatial representations, logical-mathematical analyses, bodily movements, understanding others or ones’ self, and naturalist thinking (Gardner, 1991; Gardner, 1999). Gardner’s theory of multiple intelligences (MI) has a rather different underlying structure than many of the current learning-style theories. According to Armstrong (1994), the MI theory is a cognitive model that seeks to describe how individuals use their intelligence to problem solve. However inviting it may be to correlate MI and other learning style models, Gardner’s technique is directed at how the human mind performs on the contents of the world. By contrast, the other learning style models are mainly process oriented. For example, in a sensory-channel model



(visual-auditory-kinesthetic), it is possible to be deaf and be quite musical or blind and have spatial intelligence, as MI is not bound to the senses (Armstrong, 1994).

Dissertation research reveals significant findings related to learning style and learning environment preferences. MacMurren (1985) found that when sixth grade students were matched with their preferences for intake, they achieved significantly higher than when mismatched. Pizzo (1981) declares that when sixth grade students were matched with learning style preferences, statistically higher reading and attitude scores resulted. She also contends that students who were mismatched, achieved significantly below the matched students. Cafferty (1981) reports that the greater the match between the students' and the teachers' style, the higher the grade point average. Likewise, the greater the mismatch between the students and teachers' style, the lower the grade point average. Krinsky (1981) found that students who favored bright light performed better when tested in brightly lit areas. The students who preferred dim light performed equally as well in a dim setting. When placed in mismatched light environment, the students performed statistically less well.

#### Learning Styles and Science Education

In spite of findings from learning style research, "Educators use the same traditional environments, instructional practices, and methods, showing little concern for academic potential of students except those with gross deficits" (Foriska, 1992) (p. 14). Educators in the '90's must change their beliefs and break from convention. Foriska (1992) illustrates the use of the National Association of Secondary School Principals' Learning Style Profile (LSP) and its implications in the science classroom. Using cognitive data of seventh grade science students furnished by the LSP, cognitive skill deficiencies were identified. Through the profile data of students, the deficit areas of sequencing, memory, and discrimination were enhanced through effective instructional design. Instructional interventions through new approaches and resources resulted in overall class achievement increases. The scores in the science class that received intervention surpassed those of science students who did not receive instructional intervention (Foriska, 1992).

Learning styles in science was the focus in the utilization of Bernice McCarthy's 4MAT system. As Wheeler (1988) notes, "The work of Bernice McCarthy and the development of her 4MAT System is seen to be especially relevant to the analysis of learning styles in the science classroom" (p. 7). As noted previously in this review, the 4MAT system enables students to

perceive experiences and information on a scale ranging from Concrete-Experiencing to Abstract-Conceptualization.

Science teachers are exceptional in meeting the needs of the Type Two learner (analytical), however; to reach all students, all four styles should be reflected through science instruction. Teachers can meet the needs of all four learner types (brainstormers, concrete, active, and risk takers in the classroom by moving through the four quadrants of the 4MAT System (Wheeler, 1988). As Wheeler has remarked (1988), "Science teachers who recognize a diversity of learning styles systematically expose all students to multiple instructional techniques, while maintaining full support for each student's primary learning style" (p. 9). The 4MAT System suggests that by not responding to each of the four learner types in the classroom, merely twenty-five percent of the students are being reached at a given time (Wheeler, 1988).

Research to support that students perform better in an environment that matches their preference was conducted by Okebukola (1986) in his review of preferred learning styles on cooperative learning in science education. Student preference for competitive or cooperative learning was measured using a modified form of the Learning Preference Scale (LPS). This instrument requires the student to give information pertaining to their preference for competitive or cooperative work. Results of his research with biology students demonstrate that the students who showed a preference for cooperative work achieved significantly better in a cooperative learning environment than those who were mismatched (e.g., those students who demonstrated a preference for cooperative learning and were placed in a competitive environment). Although there is compelling evidence favoring the use of cooperative learning in science, science teachers must realize that the mode of acquiring knowledge by students is not universal throughout (Okebukola, 1986).

#### Teacher Beliefs

Research studies substantiate the need for identifying students' preferred learning style and for teaching in ways that compliment that style. Confirmation from research findings report that academic achievement is elevated when students are instructed through their preferred learning style (Dunn & Bruno, 1985; Foriska, 1992; Okebukola, 1986).

The activities that teachers and students become engaged in determine how much learning takes place. Research supports the idea that the teacher is the critical change agent in paving the way to educational reform and that teacher beliefs are precursors to change (Ajzen & Fishbein,

1980; Battista, 1994; Crawley & Koballa, 1990; Pajares, 1992). Bandura (1986) asserts that behavior is better predicted from an individual's beliefs and that beliefs are believed to be the best indicators of the decisions individuals make throughout their lives. He also reveals that people regulate their level and distribution of effort in accordance with the effects they expect their actions to have.

Pajares (1992) believes that clusters of beliefs around a particular situation form attitudes. These attitudes ultimately become causative agents; people act upon what they believe. Persons' values that direct their life and determine their behavior are formed from connections among these clusters of beliefs (Ajzen, 1985). Since teachers possess beliefs regarding professional practices and these beliefs impact their actions, Cuban (1990) suggests that careful examination be given to the role of teacher beliefs so that the problems and past failures in educational reform can be identified and remedied. The behavior of teachers is influenced by an assortment of incentives and limitations. Some of the influences on behavior consist of curriculum mandates, supporting materials, working conditions and resources (NRC, 1988).

Pajares (1992) offers a synthesis of findings on beliefs which are as follows:

1. Beliefs are formed early and tend to be self-perpetuated. They tend to be preserved throughout time, experience, reason and schooling.
2. People develop a belief system that houses all the beliefs acquired through the process of cultural transmission.
3. Beliefs are prioritized according to their connections or relationship to other beliefs.
4. The earlier a belief is incorporated into the belief structure, the more difficult it is to change.
5. Belief alteration is relatively rare during adulthood.
6. Beliefs strongly influence perception.
7. The beliefs individuals possess strongly affect their behavior.
8. Beliefs about teaching are well established by the time a student attends college
9. Beliefs play a key role in defining tasks and selecting the cognitive tools with which to interpret, plan, and make decisions regarding such tasks.

The Pajares review illustrates the notion that beliefs play a critical role in defining behavior and organizing knowledge and information. Therefore, the understanding of belief structures of educators is essential to improving teaching practices as they ultimately affect the behavior of the teacher in the classroom. However, beliefs are masked by attitudes, judgments, opinions, ideologies, values, theories, and perceptions (Pajares, 1992).

Belief structures of teachers have been explored by Battista (1994) and he reveals that teachers are key to the success of the current reform movement in U.S. mathematics education.

He continues to note that a great number of teachers have beliefs about mathematics that are not consistent with those that are guiding the reform effort. This incompatibility in belief structure, will impede reform effort therefore preventing curricular change. It is imperative to take into account teacher beliefs regarding reform efforts. Failure to do so may result in the continual return of reform efforts (Battista, 1994; Cuban, 1990).

## **THEORETICAL BASE**

### Theory of Planned Behavior

The theory of planned behavior (TPB) (Ajzen & Madden, 1986) has been shown to be instrumental in identifying belief-based factors influencing behavior and intention. The Theory of Planned Behavior states that what an individual does is determined by personal motivation which is determined by attitude, social support, and perceived behavioral control. These factors are grounded by the persons' perception of the social, personal, and situational consequences of the specified action.

Ajzen's (1985) Theory of Planned Behavior has been widely used in science education research to predict a person's intent to participate in a specified behavior (Crawley & Black, 1992; Crawley & Koballa, 1992; Czerniak & Lumpe, 1996; Czerniak, Lumpe, Haney, & Beck, 1999; Czerniak, Lumpe, & Haney, 1999; DeSouza, 1994; Haney, 1994). The TPB has been used successfully by many researchers in science education to explore behaviors that trace the correlation of beliefs to behavior. Crawley and Black (1992) support the use of TPB by science educators who are interested in identifying the instrumental beliefs that students hold through their research regarding enrollment in elective science courses. Crawley (1988) reports that attitude toward behavior is the sole determinant of teachers' intentions to engage a specified behavior. He found that teachers' personal beliefs concerning the consequences of using investigative methods to teach physical science strongly influence their attitude toward doing so. Crawley and Koballa (1990) utilized TPB to study Hispanic-American students' attitudes toward enrolling in high school chemistry. They concluded that the students' intentions directly affect their decision to register for a chemistry course. According to Crawley and Koballa (1990), the students are motivated to do so because of favorable attitudes toward chemistry.

According to Ajzen's Theory, the intent to engage in a behavior (BI) is the best predictor of behavior (B). Behavioral intent (BI) is determined by three constructs: attitude toward the behavior (AB); subjective norm (SN); and perceived behavioral control (PBC).

Attitude toward the behavior represents the extent to which an individual believes the target behavior will lead to desirable consequences. This depends upon the person's perceived consequences of performing the behavior ( $b_i$ ) and on the person's evaluation of each of the consequences ( $e_i$ ). The relationship is illustrated in the following equation:

$$AB = \sum b_i e_i$$

Subjective norm (SN) measures the extent to which the person believes that others who are considered important to them think the behavior should be performed. This is concluded by what the person perceives to be the expectations of others, called normative believe ( $n_k$ ), and the individual's motivation to comply ( $m_k$ ) with the others' expectations. This relationship is depicted in the following equation:

$$SN = \sum_k n_k m_k$$

Perceived behavioral control (PBC) measures the person's beliefs as to how difficult or easy the behavior is likely to be based on external and internal factors. External factors may consist of time and money, whereas, internal factors may consist of knowledge and ability. Individuals associate a limited number of controls with performance of a specific behavior (control beliefs,  $c_b$ ) and weight each of these controls by the likelihood that it will be a contributing factor (likelihood of occurrence,  $l_o$ ). Both of these components ( $c_b$  and  $l_o$ ) combine to form a self-efficacy judgment. The components of PBC are illustrated through the following equation:

$$PCB = \sum_n (cb)_n (Io)_n$$

The following equation demonstrates the relationship among the variables:

$$B \sim BI \sim (AB + SN + PBC) = w_1 AB + w_2 SN + w_3 PBC$$

whereas  $w_1$ ,  $w_2$ , and  $w_3$  represent the relative contributions, or weights, that the attitude, subjective norm, and perceived behavioral control constructs make to the prediction of intention and subsequent behavior.

Direct measures of these three constructs (ABD, SND, PBCD) are directly influenced by an individual's antecedent salient beliefs and evaluations of those beliefs. These salient beliefs depict specific beliefs about the target behavior and produce indirect measures of the three measures (ABI, SNI, PBCI). This theoretical structure is causal and unidirectional. The Theory

of Planned Behavior connects a behavior to their beliefs, social support, and attitude (see Figure 1).

---

Insert Figure 1 About Here

---

### **PURPOSE**

The purpose of this study was to determine the relationship between the belief structures of K-12 science teachers regarding the use of a variety of instructional strategies to meet the needs of different learning styles and the intent to implement these strategies in their own classrooms. In addition, this study assessed the relationship between these belief structures and the teachers' perceived implementation of these recommendations in their classroom.

Recent science education reform movements reflect the need for teachers to employ a variety of instructional strategies to meet the needs of different learning styles. Teachers' beliefs may play a critical and instrumental role in the implementation of a variety of instructional strategies in the classroom. Based on this premise, the researchers sought answers to the following questions:

1. Can the components of the Theory of Planned Behavior predict teachers' intent to implement a variety of instructional strategies into their science classroom instruction to meet the needs of different learning styles?
2. Which salient beliefs (ABI, SNI, PBCI) make significant contributions towards the attitude toward the behavior, subjective norm, and perceived behavioral control?
3. Is there a relationship between intent to implement a variety of instructional strategies to meet the needs of different learning styles and demographic variables (gender, ethnicity, grade level assignment, degree earned, and years of teaching experience)?
4. Is there a relationship between the relative contributions of the intent predictors (AB, SN, PBC) and the demographic variables (gender, ethnicity, grade level assignment, degree earned, and years of teaching experience)?

### **METHODS**

### The Subjects

Two samples of teachers were used for this study. The first sample consisted of twenty-eight teachers from urban, rural, and suburban school districts in Northwest and Northeast Ohio. These teachers were asked to volunteer to answer an open-ended questionnaire. They represented a variety of years of teaching experience and grade levels. This sample was purposefully selected to solicit salient beliefs regarding the implementation of a variety of instructional strategies to meet the needs of different learning styles. According to Ajzen and Fishbein (1980), individuals can identify their salient beliefs of the consequences, personal support, and control associated with participation in a specific behavior through a series of open-ended questions. The specific behavior for this study is described as “implementation of a variety of instructional strategies to meet the needs of different learning styles in the science classroom.” The data compiled from this first group was used to create the final questionnaire.

The second sample used for this study consisted of randomly selected K-12 teachers in the 18 county northwest region of Ohio. A mailing list of schools was obtained from The Science, Mathematics, and Technology Education Center (SciMaTEC) at the University of Toledo (SciMaTEC, 1997). This list contains names and addresses of teachers who receive the SciMaTEC quarterly newsletter. The newsletter is composed of information related to science, mathematics, and technology with an emphasis on professional development opportunities. A random sample of two hundred fifty names out of forty-two hundred names was selected for this mailing.

One hundred ten surveys were returned yielding a 44% return rate. Teaching experience represented by the achieved sample ranged from one to thirty –seven years. Twenty-one percent of the respondents had 0-10 years of experience, 45% of the respondents had 11-20 years of experience, 33% of the respondents had 21-30 years of experience, and 1% of the sample reported more than thirty years of teaching experience. Fifty-four percent of the respondents hold a master’s degree, 45% possess bachelor’s degrees, and 1% have obtained a Doctorate or Specialist degree. More females responded than males which represented 60% of the responses. Primary grade teachers (K-4) represented 27% of the sample, intermediate grade teachers (5-8) represented 33% of the sample, and 39% of the respondents were high school teachers (9-12). Ethnic data included 95% of the respondents as Caucasian/White, 3% of the respondents were

African American, 1% of the respondents were Hispanic, and 1% revealed ethnic background as “Other.”

### The Questionnaire

Using Ajzen and Fishbein’s (1980) method for developing standard questionnaires to assess peoples’ salient beliefs related to participating in a given target behavior, the first sample of K-12 teachers were asked to answer open-ended questionnaires. These questions assessed their beliefs about implementing a variety of instructional strategies to meet the needs of different learning styles.

The salient beliefs about the attitudes toward the defined target behavior were elicited using the following questions:

1. What do you view as the advantages of implementing a variety of instructional strategies to meet the needs of different learning styles in the science classroom?
2. What do you view as the disadvantages of implementing a variety of instructional strategies to meet the needs of different learning styles in the science classroom?
3. Is there anything else that you associate with implementing a variety of instructional strategies to meet the needs of different learning styles in the science classroom?

Next, the salient beliefs about the social support for engaging in the target behavior were identified using similar questions:

1. Who are the groups or people who would approve of you implementing a variety of instructional strategies to meet the needs of different learning styles in the science classroom?
2. Who are the groups or people who would disapprove of you implementing a variety of instructional strategies to meet the needs of different learning styles in the science classroom?
3. Are there any other groups or people who come to mind when you think about implementing a variety of instructional strategies to meet the needs of different learning styles in the science classroom?

Finally, the salient beliefs about factors that help or hinder engagement in the specific behavior were identified using the following questions:

1. What things could happen that would make it easy for you to implement a variety of instructional strategies to meet the needs of different learning styles in the science classroom?
2. What things could happen that would make it difficult for you to implement a variety of instructional strategies to meet the needs of different learning styles in the science classroom?



3. What other things come to mind that might influence whether you implement a variety of instructional strategies to meet the needs of different learning styles in the science classroom?

The information obtained from these open-ended questionnaires was compiled and content-analyzed. Bipolar items were constructed using the salient beliefs that the sample group held about implementing a variety of instructional strategies to meet the needs of different learning styles. According to Ajzen and Fishbein (1980), only those salient beliefs representing a majority (75%) of beliefs are to be selected for questionnaire item construction. The items were constructed using a 5-point bipolar semantic differential scale. These items constituted the indirect measures of the three major constructs: attitude toward the behavior (ABI), subjective norm (SNI), and perceived behavioral control (PBCI). Based on the Theory of Planned Behavior, the salient beliefs were combined according to the linear equation described by Ajzen and Fishbein (1980) to form indirect measures. Bipolar scales designed to assess the direct measures of attitude toward the behavior (ABD), subjective norm (SND), and perceived behavioral control (PBCD), and behavioral intention (BI) were constructed according to Ajzen and Fishbein's (1980) standard technique. Examples representing the salient beliefs and corresponding questionnaire item for each type of question (AB, SN, and PBC) are provided below. For the AB salient belief that implementing a variety of instructional strategies to meet the needs of different learning styles "increases all student's success in the class," the following questionnaire item was constructed:

"My implementing a variety of instructional strategies to meet the needs of different learning styles into my science classroom would increase all student's success in the class."  
 unlikely      \_\_\_\_\_      \_\_\_\_\_      \_\_\_\_\_      \_\_\_\_\_      likely  
                   very      slightly      neither      slightly      very

Similarly, for the SN salient belief that "administrators are supportive of implementing a variety of instructional strategies to meet the needs of different learning styles," the following questionnaire item was constructed:

"Administrators think that I should implement a variety of instructional strategies to meet the needs of different learning styles."  
 unlikely      \_\_\_\_\_      \_\_\_\_\_      \_\_\_\_\_      \_\_\_\_\_      likely  
                   very      slightly      neither      slightly      very

Likewise, the for PBC salient belief that "available resources" (funding, curriculum materials, supplies, equipment, etc.) would encourage the implementation of a variety of instructional

strategies to meet the needs of different learning styles, the following questionnaire item was constructed:

“Having available resources (funding, curriculum materials, supplies, equipment, etc.) would encourage the implementation of a variety of instructional strategies to meet the needs of different learning styles.”

unlikely      \_\_\_\_\_      \_\_\_\_\_      \_\_\_\_\_      \_\_\_\_\_      \_\_\_\_\_      likely  
                                very      slightly      neither      slightly      very

The lists of salient beliefs used to construct the final questionnaires are depicted in Tables 1-3.

---

Insert Tables 1-3 About Here

---

### Reliability and Validity

Previous research, using the same type of respondent population employed in this study, have calculated reliability coefficients. Lumpe, Haney, and Czerniak (1996) calculated reliability coefficients for the three direct measures (ABD, SND, PBCD). Test-retest correlations were found to range from .80 to .86, and alpha internal consistency coefficients ranged from .83 to .88. In addition, Haney (1994) calculated reliability coefficients for the three direct measures that ranged from .73 to .92. For this study, reliability indices for the indirect attitude, subjective norm, and perceived behavioral control scales were calculated using Cronbach’s alpha internal consistency coefficient and were found to be as follows: (ABI=.59; SNI=.83; PBCI=.83).

Validity of the scales for the indirect and direct measures of the TPB can be inferred from two sources. First, content validity can be inferred from the indirect measures since the salient beliefs emerged from teachers’ own responses to the open-ended questions. Second, construct validity can be inferred from the significant correlations existing between the direct and indirect measures of the AB,SN, and PBC constructs (see Figure 2).

### Data Analysis

A variety of statistical methods were conducted using the SPSS Version 6.1 (Nouriss, 1994) computer statistical analysis package. Descriptive statistics, correlations, reliability, regression models, ANOVAS, and Scheffe post hocs were calculated. The first regression analysis determined the relative contribution of the indirect variables (ABI, SNI, and PBCI) to the direct

variables (ABD, SND, and PBCD). The second regression determined the relative contribution of the direct variables (ABD, SND, and PBCD) to the behavioral intent (BI). One-way ANOVA methods were employed to examine differences between the demographic variables (race/ethnicity, gender, grade level assignment, degree earned, and years of teaching experience) and the variables of AB, SN, PBC, and BI. All paths represent direct effects; therefore, path coefficients are represented by betas from multiple regression models. The betas were used to determine the relative contribution of each variable.

## RESULTS

Research Question 1: Can the components of the Theory of Planned Behavior predict teachers' intent to implement a variety of instructional strategies into their science classroom instruction to meet the needs of different learning styles?

The open-response items used to construct the ABI, SNI, and PBCI scales were used to address Research Question 1 (see tables 1-3). Many of the advantages for using learning styles listed by the teachers focus on making science interesting for the students and helping students learn. Some teachers were concerned about the time and effort it took to plan for learning styles. The approving and disapproving groups of people include many of the groups who commonly interface with schools (administrators, teachers, students, and parents). Some teachers indicated available resources (funding, curriculum materials, supplies & equipment, etc.) and staff development opportunities would encourage them to use a variety of instructional styles to accommodate student learning. Others stressed the importance of collegial, administrative support, and Board of Education support. Finally, they also reported that more time and smaller classes would encourage them to use a variety of instructional strategies.

---

Insert Tables 1-3 about here

---

Research question 2: Which salient beliefs (ABI, SNI, PBCI) make significant contributions towards the attitude toward the behavior, subjective norm, and perceived behavioral control?

Descriptive statistics can be seen in Table 4. The teachers generally maintain positive beliefs concerning attitude (ABI) as indicated by their mean score. The low mean for PBCI indicates that the teachers don't feel that specific external control factors such as planning time, resources, and staff development will be present in order to help them implement a variety of instructional strategies to meet the needs of different learning styles. The mean for ABD indicates that the teachers have fairly positive attitudes about implementing a variety of instructional strategies. The mean of SND indicates that on average, the teachers are influenced by other people. Likewise, the mean score of PBCD reveals the belief that the teachers could easily implement a variety of instructional activities, while the mean for behavioral intention (BI) indicates that the teachers believe that they are likely to implement a variety of instructional strategies to meet the needs of different learning styles.

---

Insert Table 4 about here

---

The regression analyses (Figure 2) reveals several significant paths. The path coefficients represent the betas from regression models and can be used to determine the relative weights of each variable.

---

Insert Figure 2 about here

---

In stage one, the indirect measures of the theory constructs were correlated to the direct measures. The indirect measure of attitude (ABI) significantly influenced the direct measure of attitude (ABD) ( $F(1, 107) = 10.1, p = .0019, R = .29$ ) and accounted for 8% of the variance. The indirect measures of subjective norm (SNI) significantly influenced the direct measure of subjective norm (SND) ( $F(1, 107) = 6.87, p = .0100, R = .24$ ) and accounted for 6% of the variance. However, there was not a significant path from the indirect measure of perceived behavioral control (PBCI) to the direct measure of perceived behavioral control (PBCD) ( $F(1, 107) = .31, p = .5768, R = .05$ ).

In stage two, behavioral intention was regressed on the three direct measures of the theory constructs. All three measures (ABD, SND, PBCD) were significantly linked to behavioral intention ( $F(3,105)=22.3, p=.0000, R=.62$ ). Attitude toward behavior is the strongest influence of intention as indicated by its large beta of .49 ( $p=.0000$ ). Direct measures of subjective norm ( $\beta=.16, p=.0433$ ) and perceived behavioral control ( $\beta=.18, p=.0214$ ) also have influence on intention.

**Research question 3:** Is there a relationship between intent to implement a variety of instructional strategies to meet the needs of different learning styles and demographic variables (gender, ethnicity, grade level assignment, degree earned, and years of teaching experience)?

One-way analysis of variance (ANOVA) statistical techniques showed no differences on teacher intent to implement a variety of instructional strategies to meet the needs of different learning styles according to degree earned ( $F(2,105)=.466, p=.629$ ), gender ( $F(1,107)=.264, p=.609$ ), grade level assignment ( $F(2,105)=.895, p=.412$ ), or years of teaching experience ( $F(3,99)=.630, p=.597$ ). However, significant differences were found on teachers' intent according to race/ethnicity ( $F(3,104)=17.159, p=.0000$ ). Scheffe post hoc analysis showed that Caucasian/White and African American/Black respondents intent to implement a variety of instructional strategies differed significantly from Hispanic and "Other" respondents. Both Caucasian/White and African American respondents are more likely to implement a variety of instructional strategies as indicated by their intent scores that were found to be significantly different than Hispanic and "Other" respondents.

**Research question 4:** Is there a relationship between the relative contributions of the intent predictors (AB, SN, PBC) and the demographic variables (gender, ethnicity, grade level assignment, degree earned, and years of teaching experience)?

No significant differences were found on attitude toward behavior (AB) across gender ( $F(1,107)=.264, p=.609$ ), years of teaching experience ( $F(3,99)=.358, p=.784$ ), grade level assignment ( $F(2,105)=.222, p=.802$ ), and degree earned ( $F(2,105)=.941, p=.394$ ). However significant differences were found on teachers' attitude toward the behavior (AB) across

race/ethnicity ( $F(3,104)=7.437, p=.0001$ ). Scheffe post hoc analysis showed that both White/Caucasian and African American scores were significantly different than "Other" respondents. The ANOVA showed no significant differences on teachers' subjective norm (SN) across gender ( $F(1,107)=.321, p=.572$ ), years of teaching experience ( $F(3,99)=.357, p=.783$ ), grade level assignment ( $F(2,105)=.361, p=.698$ ), and degree earned ( $F(2,105)=.255, p=.776$ ). However, a significant difference was displayed on teachers subjective norm (SN) according to race/ethnicity ( $F(3,104)=4.24, p=.007$ ). Scheffe post hoc analysis showed that Caucasian/White subjective norm scores different significantly from Hispanic respondents' subjective norm scores. No differences were found on perceived behavioral control (PBC) according to demographic variables: grade level taught ( $F(2,105)=.977, p=.380$ ), years of teaching experience ( $F(3,99)=.484, p=.694$ ), gender ( $F(1,107)=2.265, p=.135$ ), race ( $F(3,104)=2.212, p=.091$ ), and degree earned ( $F(2,105)=.523, p=.595$ ).

Zero order correlations for the variables in this study can be seen in Table 5. It can be seen from the moderate correlations between the direct measures that different constructs may have been measured for this component.

---

Insert Table 5 about here

---

## CONCLUSIONS

The following conclusions, organized by research questions, are drawn from this study:

**Research Question 1:** Can the components of the Theory of Planned Behavior predict teachers' intent to implement a variety of instructional strategies into their science classroom instruction to meet the needs of different learning styles?

1. Responses from the teachers who answered the open-ended questionnaire indicate they believe that implementing a variety of instructional strategies to meet the needs of different learning styles will: increase student success, motivate students, meet all student needs, make

science a good learning experience for all students, encourage participation, and create interest in science.

2. In order to implement a variety of instructional activities, the teachers express concern with lack of necessary planning time, materials, resources, and money. The teachers are also concerned with an increase in teacher effort as well as student behavioral problems.

3. The teachers perceive that external factors (resources, planning time, staff development) will not be available in order to assist in the implementation of a variety of instructional strategies to meet different learning styles.

4. The teachers possess positive attitudes about implementing a variety of instructional strategies to meet different learning styles.

Research Question 2: Which salient beliefs (ABI, SNI, PBCI) make significant contributions towards the attitude toward the behavior, subjective norm, and perceived behavioral control?

5. The teachers indicated that they are somewhat influenced by others who are closely affiliated with the school (administrators, parents, teachers, and students).

6. Salient beliefs about implementing a variety of instructional strategies to meet the needs of different learning styles and the evaluations of those beliefs directly influences the teachers' attitudes about this specified behavior.

7. Salient beliefs about implementing a variety of instructional strategies to meet the needs of different learning styles and the evaluations of those beliefs directly influenced the teachers' subjective norm regarding the specified behavior.

8. The teachers' attitude toward the behavior and subjective norm directly influenced their intent to implement a variety of instructional strategies to meet the needs of different learning styles.

9. Attitude was the strongest influence on the teachers' intent to implement a variety of instructional strategies to meet the needs of different learning styles.

Research Question 3: Is there a relationship between intent to implement a variety of instructional strategies to meet the needs of different learning styles and demographic variables (gender, ethnicity, grade level assignment, degree earned, and years of teaching experience)?

10. Caucasian and African American respondents are more likely to implement a variety of instructional strategies to meet the needs of different learning styles.

Research Question 4: Is there a relationship between the relative contributions of the intent predictors (AB, SN, PBC) and the demographic variables (gender, ethnicity, grade level assignment, degree earned, and years of teaching experience)?

11. Caucasian and African American respondents have the most positive attitudes about implementing a variety of instructional strategies to meet the needs of different learning styles.

12. Race/ethnicity affects the subjective norm of implementing a variety of instructional strategies to meet the needs of different learning styles in the science classroom.

## DISCUSSION

The theory of Planned Behavior was beneficial in exploring the relationship of teacher beliefs concerning the implementation of a variety of instructional strategies to meet the needs of different learning styles in the science classroom. Recent science reform documents include a common theme asking teachers to incorporate a plethora of pedagogical methods to meet the different needs of a variety of learning styles. This theme supports the common philosophies of the reform projects ... "science is for all students" (AAAS, 1997, NRC, 1996; ODE, 1994); Rutherford & Ahlgren, 1996). However, since the inclusion of a variety of instructional strategies to meet the needs of different learning styles is desired, the role of teachers' beliefs in their implementation of this particular reform strand must earnestly be taken into account. Otherwise, most of what occurs in schools today will remain caught in the undertow of the status quo. The Holmes Group (1995), believes that "changes, by and large, flitter at the margins, touching only the edges of teaching and learning" (p.7). In order for teachers to focus on this particular strand, systemic changes must occur, beginning with examining and addressing teaching belief structures.

As this study investigated beliefs and behavioral intent, the results disclose that attitude was the strongest influence on teachers' intent to implement a variety of instructional strategies. Consequently, it is essential to help foster positive attitudes toward learning styles. Teachers should be involved in positive experiences that show how they can implement these strategies in



their own classroom. Teachers should be provided with concrete and successful experiences through pre-service training and also through on-going staff development.

Bandura (1986) declares that self-efficacy can be fostered through observing success, experiencing success, persuasion techniques, and positive emotional tone. Feedback is also a crucial component that aids the successful experience. Therefore, teacher training experiences should include enough opportunities to 1) collaborate with colleagues who are implementing the same strategies, 2) visit classrooms that use multiple instructional strategies and focus on student learning styles, 3) observe student and teacher success, 4) develop and/or pilot instructional materials, 5) practice using these strategies with colleagues in order to receive feedback, 6) participate in and present activities that foster learning styles at workshops and inservice programs. Bandura (1977) states, "people fear and tend to avoid threatening situations they believe exceed their coping skills, whereas they get involved in activities and behave assuredly when they judge themselves capable of handling situations that would otherwise be intimidating" (p. 194). Consequently, by providing successful opportunities for teachers, a positive attitude may be reflected. It is imperative to focus on teachers' attitudes in order to implement reform recommendations.

Crawley and Koballa (1992) review an intervention plan to assist in the positive development of attitudes. The six steps of the plan are: 1) specify the target behavior, 2) determine the salient beliefs of the target groups, 3) design the attitude-behavior questionnaire, 4) develop the persuasive message, 5) conduct the intervention program, and 6) assess the attitude behavior outcomes. This plan may be used with teachers as they are asked to implement recent science reform recommendations.

Staff development for teachers should target the salient beliefs that appear to influence their intentions and actions. This strategy may help cultivate positive beliefs. Many of the teachers who responded to the open-ended questionnaire appear to perceive certain benefits when a variety of instructional activities are implemented. These benefits include increasing student success, creating student interest, and making science a positive learning experience for all students.

In addition, staff development should posit a different philosophy than the traditional one (i.e. controlled by administration). As noted by the Holmes Group (1995) the status of teachers in public schools suffers when they are excluded from decisions and treated like instructional

robots. Teachers should be involved in planning and participating in staff development activities. Teaching must be regarded as intellectually challenging work and prospective and practicing teachers should be capable of making informed professional judgments. Active participation and decision making may empower and excite teachers. This may lead to the development of positive attitudes.

Lack of planning and instructional time were major concerns for some teachers. These teachers may view incorporating a variety of instructional strategies as just another thing to add to their busy day. Using persuasion techniques and providing these teachers with the opportunity to experience success may alter this belief. Block scheduling is an alternative to the traditional school schedule (40-50 minute class periods) that would enable teachers to have more time to plan, more daily instructional time, and less students. The block schedule typically provides teachers with four, ninety-minute periods per day. The lengthened instructional strategy is intended to foster deeper understanding of concepts in students (Canady, 1995). Teachers feel more relaxed and better capable of experimenting with multi-faceted instructional activities with the lengthened instructional period (Hartzell-Ballone, 1999).

Teachers also expressed a need for necessary curricular materials. Having available curricular materials may also play a crucial role in implementing a variety of instructional strategies to meet the needs of different learning styles. For example, instructional materials that help meet the needs of different learning styles should include: 1) hands-on materials, 2) textbooks, 3) videos, 4) audio recordings, 5) visual aides, 6) cooperative group activities, 7) computer-technology related activities, 8) outdoor-related activities, 9) kinesthetic activities, and 10) creative art activities (Armstrong, 1994; Dunn & Dunn, 1979). Teachers should be given the opportunity to develop and implement these activities in their own classroom. Successful implementation with the necessary funds and materials may yield positive attitudes which will help to reinforce current reform recommendations.

Teachers were also concerned with a classroom management factor as many felt that behavioral problems could impede the inclusion of a variety of instructional activities. The difficulty in handling a classroom with many different learning styles poses a challenge to many educators. However, many students express behavior problems due to boredom or frustrations that may stem from the type of instruction that is typically given. Teachers, for the most part, use whole-class lectures and discussions as primary modes of instruction. Armstrong (1994)

reveals, "For most Americans, the word classroom conjures up an image of students sitting in neat rows of desks facing the front of the room, where a teacher either sits at a large desk correcting papers or stands near a blackboard lecturing students" (p. 86). He continues to reveal that this method of classroom arrangement is neither the only nor the best method. Teachers should be shown how to set up a classroom in which a variety of learning activities or "stations" are simultaneously occurring. Teachers should be shown how to use small-group and team learning techniques for those students who 1) like to work with other classmates, 2) strain in their seats when required to sit and listen, 3) appear not to remember what has been taught, or 4) may have difficulty paying attention at the time of day the lesson is scheduled. As small group work is taking place, the teachers may teach to a small group who prefers a traditional method of instruction. Self-motivated, responsible, and gifted students may prefer to work alone (Armstrong, 1994; Dunn & Dunn, 1979). Other pedagogical methods may be to simply provide variety with daily lessons (i.e., hands-on activities, computer activities, lecture, discussion, video, group work, individual projects, lab work, library research, inquiry activities, simulations, etc.) as this may be critical in meeting the needs of different learning styles and maintaining interest.

In order for teachers to implement a variety of instructional strategies, they need ongoing opportunities to build their understandings and abilities (NRC, 1996). These ongoing opportunities may include attending workshops, observing model classrooms, or studying and engaging in research. Each of these experiences should give teachers the chance to plan and work with colleagues in order to facilitate change. For example, teachers could be given the opportunity to study and engage in collaborative research and share with colleagues what they have learned.

Ethnic differences were reported as Caucasian and African American respondents displayed the most positive attitudes about implementing the targeted behavior. Caucasians and African American respondents also revealed that they are more likely to implement the target behavior. Ethnicity also affected the subjective norm of implementing a variety of instructional activities. However, as previously revealed, the response rate yielded: 95% Caucasian, 3% African American, 1% Hispanic, and 1% "Other." The low response rate from Hispanic and Other groups may have contributed to these significant differences. More research in this area is imperative as a larger response from these ethnic groups may show different results.

The subjective norm (SN) made significant contributions toward behavioral intent. This finding reveals that teachers believe that people who are important to them influence their intent to implement a variety of instructional strategies. Haney (1994), Beck (1997), Hartzell-Ballone (1999) research reveals that administrative support is important to teachers. These researchers note that the administration (e.g., building principals) should participate in staff development experiences. The administration should also take an active role in evaluating both teacher and project effectiveness in order to facilitate change. In addition, collaborative reflection such as peer coaching, peer mentoring, lead teachers, teacher advisers, and resource teachers should be employed as professional development strategies (Loucks-Horsley, 1998; Loucks-Horsley, Hewson, Love, & Stiles, 1998; NRC, 1996).

Perceived behavioral control (PBC) beliefs did not make significant contributions toward intent. This finding suggests that teachers feel staff development opportunities and available resources (funding, curriculum materials, etc.) may not be available to them. Consequently, without the proper support system, current reform recommendations will be difficult to implement. Lack of necessary resources may result in an ineffective science program and contribute to poor teacher attitudes. Teachers may begin to view reform suggestions as passing fads. The history of reform follows this trend as many experienced teachers have been through unsuccessful reform efforts in the past. The National Science Education Standards (1996) addresses this issue as it states that effective science programs require: 1) resources of people, 2) time, 3) materials, 4) money, 5) staff development, and 6) leadership. Leadership may be vested from a plethora of sources such as science coordinators, teachers, and school administrators. The provider of the leadership is not as crucial as ensuring that the responsibilities for support, maintenance, assessment, review, revision, and improvement of the program are properly carried out (NRC, 1996). Therefore, it is critical that external support for science reform suggestions become an integral component in the change process.

In conclusion, the results and conclusions of this research study offer support for Azjen's (1985) Theory of Planned Behavior (see Figure 1 for depicted relationship), and it offers valuable information to the contemporary science education reform movement. Attitude toward the behavior (AB) and subjective norm (SN) made significant contributions to intent. Moreover, AB was found to be the greatest contributor of teachers' intent to implement a variety of instructional strategies to meet the needs of different learning styles. Particularly, this study

supports the body of research that affirms that teacher beliefs are critical components of classroom behavior (Battista, 1994; Beck, 1997; Crawley, 1990; Crawley & Black, 1992; Crawley & Koballa, 1992; Czerniak & Lumpe, 1996; Czerniak, Lumpe, Haney, & Beck, 1999; Czerniak, Lumpe, & Haney, 1999; DeSouza, 1994; Haney, 1994; Lumpe, Haney, & Czerniak, 1996; Pajares, 1992). Successful science education reform should focus on the role of teacher beliefs. Changes in belief structures may result by fostering positive attitudes and implementing appropriate staff development opportunities.

More research should be conducted regarding the role of teachers' beliefs and their classroom practice. The particular study dealt with a strand associated with science education reform. A follow-up study examining the relationship between the teachers' predicted intent and actual behavior in the science classroom would be productive. Also, qualitative studies examining the belief structures of teachers may be beneficial in understanding the relationship between intention and teacher beliefs.

Table 1. Advantages and Disadvantages of Implementing a Variety of Instructional Strategies to Meet the Needs of Different Learning Styles I the Science Classroom

---

Advantages

---

It will make science a good learning experience for all students  
It will increase student success in the class.  
It will encourage all students to become participants.  
It will require smaller class sizes.  
All students needs will be met.  
Create student interest.  
Develop a need for inservice.  
Require more materials to be used for activities.  
Extend instructional time with students.

---

Disadvantages

---

It may be difficult because of behavior problems.  
Require more planning.  
Require more teacher effort.

---

Table 2. People Who Approve or Disapprove of Implementing a Variety of Instructional Strategies to Meet the Needs of Different Learning Styles in the Science Classroom

---

Approve

---

School Administrators  
Students  
Special Education Teachers  
Board of Education  
Parents of Special Education Students  
Parents  
Teachers

---

Disapprove

---

Traditional Teachers  
Parents

---

Table 3. Things That Would Encourage or Discourage the Implementation of a Variety of Instructional Strategies to Meet the Needs of Different Learning Styles in the Science Classroom

---

Encourage
Resources and Materials
Parental, Collegial, Administrative Support
More Planning Time
Extended Instructional Time
Small Class Sizes
Staff Development

---

Discourage
Behavioral Problems
Lack of Materials and Resources
Lack of Administrative Support

---



Table 4

Descriptive Statistics

Variable	Mean	SD	Minimum	Maximum
ABI	29.85	12.74	.00	71.00
SNI	12.36	9.66	-8.00	48.00
PBCI	4.87	15.38	-60.00	40.00
ABD	23.84	2.45	14.00	28.00
SND	11.78	2.19	5.00	15.00
PBCD	8.88	1.30	4.00	10.00
INTENT	13.76	2.24	3.00	15.00

n=109

Table 5

Zero Order Correlations

	ABI	SNI	PBCI	ABD	SND	PBCD	INTENT
ABI	1.00	.2542* *	.0920	.2939* *	.1643	.2013*	.2758**
SNI		1.00	.3292***	.3350***	.2456*	.2859**	.2316*
PBCI			1.00	.1250	.1530	.0540	.1082
ABD				1.00	.2167*	.2394*	.5728***
SND					1.00	.1409	.2935**
PBCD						1.00	.3250**
INTENT							1.00

n=109

\*  $p < .05$

\*\*  $p < .01$

\*\*\*  $p < .001$

Figure 1  
Theory of Planned Behavior

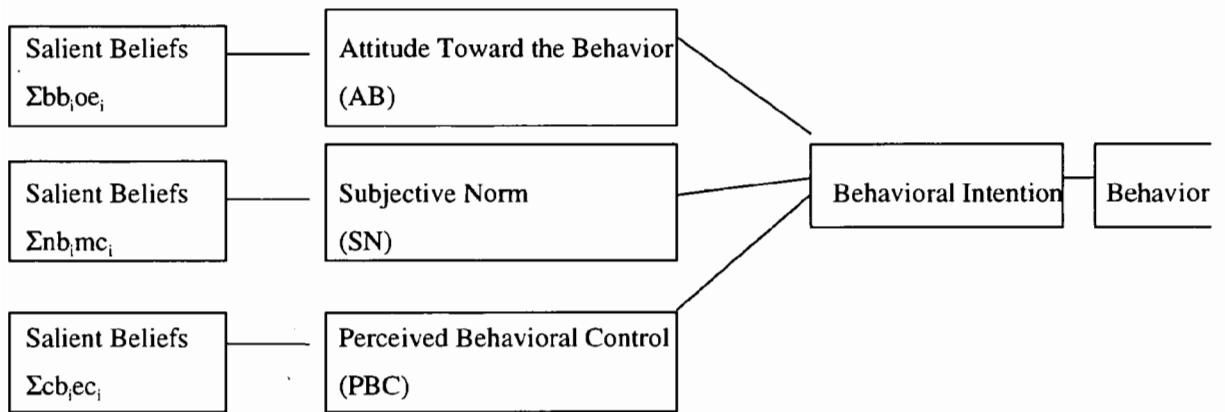

Key:

- bb = behavioral beliefs
- oe = outcome evaluation
- nb = normative beliefs
- mc = motivation to comply
- cb = control beliefs
- ec = evaluation of controls

Figure 2  
Path Model

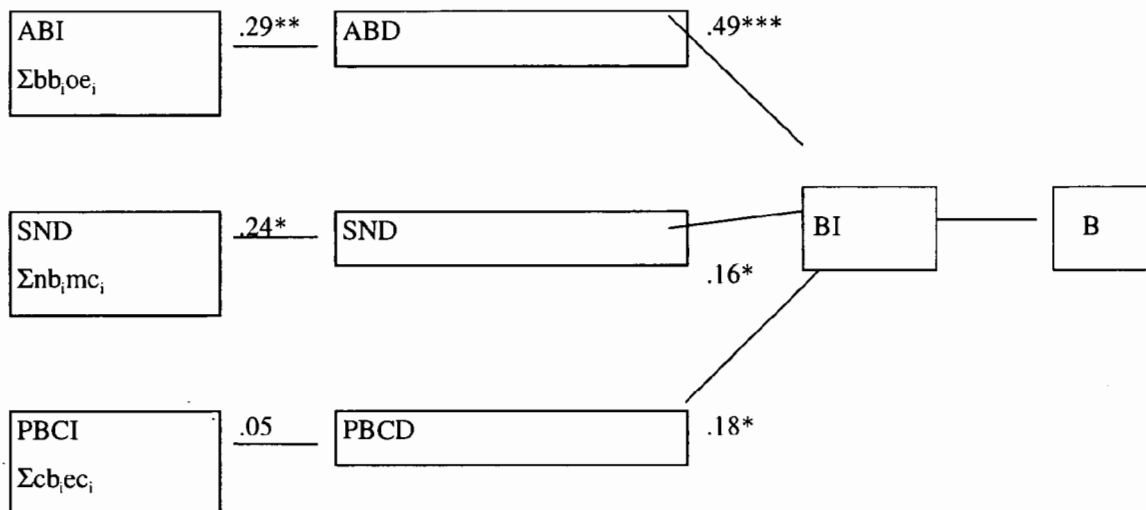

\*p = <.05

\*\* p = <.001

\*\*\*p = <.0001

## REFERENCES

- American Association For The Advancement of Science (1993). Benchmarks for scientific literacy. New York: Oxford University Press.
- American Association For The Advancement of Science (1997). Resources for science literacy: Professional development. New York: Oxford University Press.
- Ajzen I., & Fishbein, M. (1980). Understanding attitudes and predicting social behavior. Englewood Cliffs, N. J.: Prentice Hall.
- Ajzen I. (1985). From intentions to actions: A theory of planned behavior. In J. Kuhl & Bechman (Eds.), Action control: from cognition to behavior. New York: Springer-Verlag.
- Ajzen, I., & Madden, T. J. (1986). Prediction of goal-directed behavior: Attitudes, intentions and perceived behavioral control. Journal of Experimental Social Psychology, 22, 453-474.
- Armstrong, T. (1994). Multiple intelligences in the classroom. Alexandria, VA: Association for Supervision and Curriculum Development.
- Bandura, A. (1977). Self-efficacy: Toward a unifying theory of behavioral change. Psychological Review, 84, 191-215.
- Bandura, A. (1986). Social foundations of thought and action: A social cognitive theory. Englewood Cliffs, N.J.: Prentice Hall.
- Bargar, R., & Hoover, R. (1984). Psychological type and the matching of cognitive styles. Theory Into Practice, 23, 56-63.
- Battista, M. T. (1994). Teacher beliefs and the reform movement in mathematics education. Phi Delta Kappan, 75 (2), 462-470.
- Beck, J. (1997). Teachers' beliefs and their intent to implement constructivism in the classroom. Unpublished doctoral dissertation, The University of Toledo, Toledo, Ohio.
- BSCS. (1994). Innovations in science education survey instrument. Colorado Springs, CO: Author.
- Cafferty, E. (1981). An analysis of student performance based upon the degree of match between the educational cognitive style of the teacher and the educational cognitive style of the students (Doctoral dissertation, The University of Nebraska-Lincoln, 1980). Dissertation Abstracts International, 41-07, 2908.
- Canady, R. (1995). Block scheduling: A catalyst of change in high schools. Princeton, N. J.: Eye on Education.

Carbo, M., Dunn, K., & Dunn R. (1986). Teaching students to read through their individual learning styles. Englewood Cliffs, New Jersey: Prentice Hall.

Claxton, C., & Murrell, P. (1987). Implications for improving educational practices. ASHE-ERIC Higher Education Report, No. 4, Washington D. C.: Association For The Study of Higher Education.

Crawley, F. E. (1988). Determinants of physical science teachers' intentions to use investigative teaching methods: A test of the theory of reasoned actions. A contributed paper at the 1988 Annual Meeting of the National Association for Research in Science teaching, Lake Ozark, Missouri.

Crawley, F. E., & Koballa, T. R. (1990). Hispanic students' attitudes toward enrolling in high school chemistry: A study of planned behavior and belief-based change. Hispanic Journal of Behavioral Sciences, 14, 469-486.

Crawley, F. E. & Koballa, T. R. (1992). Attitudes/Behavior change in science education: Part 1-models and methods. Part 1 of a Paper Set presented at the 1992 Annual Meeting of the National Association for Research in Science Teaching, Anaheim, California.

Crawley, F. E. & Black, C. (1992). Causal modeling of secondary students' intention to enroll in physics. Journal of research in Science Teaching, 29, 585-599.

Cuban, L. (1990). Reforming again, again, and again. Educational Researcher, 19 (1), 3-13.

Czerniak, C. M., & Lumpe, A. T. (1996). Predictors of science fair participation using the theory of planned behavior. School Science and Mathematics, 96, 355-361.

Czerniak, C. M., Lumpe, A. T., and Haney, J. J. (1999) Teacher's beliefs about thematic units in science. Journal of Science Teacher Education, 10 (2), 123-145.

Czerniak, C.M., Lumpe, A. T., Haney, J.J., & Beck, J. (December, 1999). Teachers' beliefs about using educational technology in the science classroom, International Journal of Educational Technology 1 (2), <http://www.outreach.uiuc.edu/ijet>.

DeSouza, S. (1994). Do science teachers intend to engage in collaborative reflective practice? Paper presented at the annual meeting of the National Association for Research in Science Teaching, Anaheim, CA.

Dunn, R. (1988). Teaching students through their perceptual strengths or preferences. Journal of Reading, 31, 304-306.

Dunn, R., & Bruno, A. (1985). What does the research on learning styles have to do with Mario? Clearing House, 59, 9-12.

Dunn, R., & Dunn K. (1979). Learning styles/teaching styles: Should they ... can they ... be matched? Educational Leadership, 36, 238-244.

Foriska, T. (1992). Breaking room tradition: Using learning styles to teach students how to learn. Schools In The Middle, 2, 14-16.

Gardner, H. (1991). The unschooled mind: how children think and how schools should teach. New York: Basic Books.

Gardner, H. 1999. The disciplined mind. New York: Simon & Schuster.

Gregoric, A. (1979). Learning/teaching styles: potent forces behind them. Educational Leadership, 36, 234-236.

Griggs, S., & Dunn, R. (1984). Selected case studies of the learning style preferences of gifted students. Gifted Child Quarterly, 28, 115-118.

Guild, P. (1994). Making sense of learning styles. The School Administrator, 51, 8-13.

Guild, P., & Garger, S. (1985). Marching to different drummers. Alexandria, VA: Association for Supervision and Curriculum Development.

Haney, J.J. (1994). The determinants of Ohio science teachers intentions to implement the four strands of the state science model into their classroom instruction. Unpublished doctoral dissertation, The University of Toledo, Toledo, OH.

Hartzell-Ballone, L. (1999). The implementation and impact of block scheduling at one high school. Unpublished doctoral dissertation, The University of Toledo, Toledo, OH.

Holmes Group (1995). Tomorrow's schools of education. United States: The Holmes Group, Inc.

Krimsky, J. (1981). A comparative study of the effects of matching and mismatching fourth-grade students with their learning style preferences for the environmental element of light and their subsequent reading speed and accuracy scores (Doctoral dissertation, St. John's University, 1982). Dissertation Abstracts International, 43-01, 0066.

Loucks-Horsley, S. (1998). Ideas that work: Effective professional development for teachers of science. Columbus, OH: Eisenhower National Clearing House.

Loucks-Horsley, S., Hewson, P., Love, N., & Stiles, K. (1998). Designing professional development for teachers of science and mathematics. Thousand Oaks, CA: Corwin Press, Inc.

Lumpe, A.T., Haney, J.J., & Czerniak, C.M. (1996). Teacher believe and their intent to implement science-technology-society (STS) in the classroom. A paper presented at the Annual Meeting of the National Association for Research in Science Teaching, St. Louis, Missouri.

MacMurren, H. (1985). A comparative study of the effects of matching and mismatching sixth-grade students with their learning style preferences for the physical element of intake and their subsequent reading speed and accuracy scores and attitudes (Doctoral dissertation, St. John's University, 1985). Dissertation Abstracts International, 46-11, 3257.

National Research Council (1988). Improving indicators of the quality of science and mathematics education in grades K-12. National Academy Press: Washington, D.C.

National Research Council (1996). National science education standards. National Academy Press: Washington, D.C.

Nouriss (1994). SPSS 6.1 Base System Users Guide. Chicago, IL: Author.

Ohio Department of Education (1994). Model competency-based science program. Columbus, OH: State Board of Education.

Okebukola, P.A. (1986). The influence of preferred learning styles on cooperative learning in science. Science Education, 70, 509-517.

Pajares, M.F. (1992). Teacher's beliefs and educational research: Cleaning up a messy construct. Review of Educational Research, 62 (3), 307-332.

Pizzo, J. (1981). An investigation of the relationship between selected acoustic environments and sound, an element of learning style, as they affect sixth-grade students' reading achievement and attitudes (Doctoral dissertation, St. John's University, 1981). Dissertation Abstracts International, 42-06,2475.

Rutherford, F.J., & Ahlgren, A. (1990). Science for all Americans. New York: Oxford University Press.

SciMaTEC: Science, Mathematics, and Technology Education Center (1997). The University of Toledo, Toledo, Ohio.

Wheeler, A.E. (1988). Learning styles in science. Journal of Science and Mathematics Education S.E. Asia, 11, 7-11.



For each item on this rating scale, give the answer that best represents your opinion about using a variety of instructional strategies to meet the needs of different learning styles. Learning styles is defined as: Distinct behaviors that serve as indicators of how one learns and adapts to the environment. Learning styles are variations in one's behavior regarding the mode in which individuals prefer to acquire information; how one prefers to concentrate, process, absorb, and retain information.

**PART I.** For each item, select one adjective that best describes your **thoughts** by putting a mark on the appropriate line.

My implementing a variety of instructional strategies to meet the needs of different learning styles in the science classroom this school year is:

- |                |           |       |          |         |          |       |           |           |
|----------------|-----------|-------|----------|---------|----------|-------|-----------|-----------|
| 1. good        | _____     | _____ | _____    | _____   | _____    | _____ | _____     | bad       |
|                | extremely | quite | slightly | neither | slightly | quite | extremely |           |
| 2. wise        | _____     | _____ | _____    | _____   | _____    | _____ | _____     | foolish   |
|                | extremely | quite | slightly | neither | slightly | quite | extremely |           |
| 3. valuable    | _____     | _____ | _____    | _____   | _____    | _____ | _____     | worthless |
|                | extremely | quite | slightly | neither | slightly | quite | extremely |           |
| 4. challenging | _____     | _____ | _____    | _____   | _____    | _____ | _____     | easy      |
|                | extremely | quite | slightly | neither | slightly | quite | extremely |           |

**PART II.** Indicate the likelihood of each of the following **statements** by circling the appropriate number.

- |   | Very<br>unlikely | Slightly<br>unlikely | Neither | Slightly<br>likely | Very<br>likely |
|---|------------------|----------------------|---------|--------------------|----------------|
| 5. I intend to implement a variety of instructional strategies this school year to meet the needs of different learning styles.                             | 1                | 2                    | 3       | 4                  | 5              |
| 6. Generally speaking, I do what most people who are important to me think I should do.   | 1                | 2                    | 3       | 4                  | 5              |
| 7. I will try to implement various instructional strategies during this school year to meet the needs of different learning styles.                         | 1                | 2                    | 3       | 4                  | 5              |
| 8. If I wanted to, I could easily implement a variety of instructional strategies in my classroom this year to meet the needs of different learning styles. | 1                | 2                    | 3       | 4                  | 5              |
| 9. Most people who are important to me think I should implement a variety of instructional strategies to meet the needs of different learning styles.       | 1                | 2                    | 3       | 4                  | 5              |
| 10. I am aiming to implement a variety of instructional   |                  |                      |         |                    |                |

strategies into my classroom instruction during this year. 1 2 3 4 5

11. It will be mostly up to me whether or not I implement a variety of instructional strategies to meet the needs of different learner styles during this school year. 1 2 3 4 5

12. If I implemented a variety of instructional strategies into my classroom to meet the needs of different learning styles during this school year, most people who are important to me would approve. 1 2 3 4 5

**PART III.** My implementing a variety of instructional strategies to meet the needs of different learning styles into my science classroom would:

	Very unlikely	Slightly unlikely	Neither	Slightly likely	Very likely
13. require extended instructional time with students	1	2	3	4	5
14. make science a good learning experience for all	1	2	3	4	5
15. increase all student's success in the class	1	2	3	4	5
16. encourage all students to become participants	1	2	3	4	5
17. help students retain more material	1	2	3	4	5
18. demand smaller class sizes	1	2	3	4	5
19. meet the needs all students (all benefit)	1	2	3	4	5
20. be difficult because of some behavior problems	1	2	3	4	5
21. require more materials for activities	1	2	3	4	5
22. require more teacher effort	1	2	3	4	5
23. demand more planning time	1	2	3	4	5
24. create student interest	1	2	3	4	5
25. develop a need for inservice (staff development)	1	2	3	4	5

**PART IV.** Indicate your thoughts of how favorable the following issues are to science teaching by circling the appropriate number.

	Very unfavorable	Slightly unfavorable	Neither	Slightly favorable	Very favorable
26. extended instructional time with students	1	2	3	4	5
27. making science a good learning experience	1	2	3	4	5
28. increasing student success	1	2	3	4	5
29. having all students participate in class	1	2	3	4	5
30. helping students retain more information	1	2	3	4	5
31. having smaller class sizes	1	2	3	4	5
32. meeting all students needs	1	2	3	4	5
33. students who display behavior problems	1	2	3	4	5
34. having materials for activities	1	2	3	4	5

35. putting in extra effort	1	2	3	4	5
36. having more planning time available	1	2	3	4	5
37. creating student interest	1	2	3	4	5
38. inservice or staff development opportunities	1	2	3	4	5

**PART V.** Indicate the likelihood that the following people think you should implement a *variety of instructional strategies to meet the needs of different learning styles* in your classroom.

	Very Unlikely	Slightly unlikely	Neither	Slightly likely	Very likely
39. School administrators (principal, superintendent, evaluators, etc)	1	2	3	4	5
40. Students	1	2	3	4	5
41. Traditional teachers	1	2	3	4	5
42. Special education teachers	1	2	3	4	5
43. Board of Education	1	2	3	4	5
44. Parents of special education students	1	2	3	4	5
45. Parents in general	1	2	3	4	5
46. Teachers in general	1	2	3	4	5

**Part VI.** Indicate the likelihood that you will **generally do** what the following groups think you should do.

	Very Unlikely	Slightly unlikely	Neither	Slightly likely	Very likely
47. My school administrators (principal, superintendent, etc.)	1	2	3	4	5
48. Students	1	2	3	4	5
49. Traditional teachers	1	2	3	4	5
50. Special education teachers	1	2	3	4	5
51. Board of Education	1	2	3	4	5
52. Parents of special education students	1	2	3	4	5
53. Parents in general	1	2	3	4	5
54. Teachers in general	1	2	3	4	5

**PART VII.** Indicate the likelihood that the following factors would encourage you to implement a variety of instructional strategies to meet different learning styles in your classroom in the upcoming year.

	Very Unlikely	Slightly unlikely	Neither	Slightly likely	Very likely
55. Having available resources (funding, curriculum materials, supplies & equipment, etc.)	1	2	3	4	5
56. Staff development opportunities on learning styles					

& instructional strategies	1	2	3	4	5
57. Parental support	1	2	3	4	5
58. Collegial support	1	2	3	4	5
59. Extended instructional time (e.g., block schedule)	1	2	3	4	5
60. Administrative support	1	2	3	4	5
61. Time to plan	1	2	3	4	5
62. Cooperative students (less behavioral problems)	1	2	3	4	5
63. Small classes of students	1	2	3	4	5
64. Support from the Board of Education	1	2	3	4	5

**PART VIII.** Indicate the likelihood that the following factors will be available for you to use a variety of instructional strategies to meet the needs of different learning styles.

	Very Unlikely	Slightly unlikely	Neither	Slightly likely	Very likely
65. Having available resources (funding, curriculum materials, supplies & equipment, etc.)	1	2	3	4	5
66. Staff development opportunities on learning styles & instructional strategies	1	2	3	4	5
67. Parental support	1	2	3	4	5
68. Collegial support	1	2	3	4	5
69. Extended instructional time (e.g., block schedule)	1	2	3	4	5
70. Administrative support	1	2	3	4	5
71. Time to plan	1	2	3	4	5
72. Cooperative students (less behavioral problems)	1	2	3	4	5
73. Small classes of students	1	2	3	4	5
74. Support from the Board of Education	1	2	3	4	5

**PART IX.** Please complete the following **personal information** by placing a mark (x) in the space provided or by filling in the blank.

- A. Race/ethnicity: ( )Caucasian/White ( )African American/Black ( )Hispanic ( ) Other \_\_\_\_\_
- B. Gender: ( )Male ( )Female
- C. years of teaching experience: \_\_\_\_\_ years
- D. Grade Level Assignment: \_\_\_\_\_(e.g., 1<sup>st</sup> grade)
- E. Highest Degree Obtained: ( )Bachelor's ( )Master's ( )Specialist ( )Doctorate

**Please check to see that you have responded to all items. Thank you for your cooperation and time!!**



**U.S. Department of Education**  
Office of Educational Research and Improvement (OERI)  
National Library of Education (NLE)  
Educational Resources Information Center (ERIC)



## REPRODUCTION RELEASE

(Specific Document)

### I. DOCUMENT IDENTIFICATION:

Title: "Teachers Beliefs about Accomodating Students' Learning Styles in Science Classes"

Author(s): Lena M. Ballone, Ph.D, and Charlene M. Czerniak, Ph.D.

Corporate Source:

Publication Date: 12/01

### II. REPRODUCTION RELEASE:

In order to disseminate as widely as possible timely and significant materials of interest to the educational community, documents announced in the monthly abstract journal of the ERIC system, *Resources in Education* (RIE), are usually made available to users in microfiche, reproduced paper copy, and electronic media, and sold through the ERIC Document Reproduction Service (EDRS). Credit is given to the source of each document, and, if reproduction release is granted, one of the following notices is affixed to the document.

If permission is granted to reproduce and disseminate the identified document, please CHECK ONE of the following three options and sign at the bottom of the page.

The sample sticker shown below will be affixed to all Level 1 documents

<p>PERMISSION TO REPRODUCE AND DISSEMINATE THIS MATERIAL HAS BEEN GRANTED BY</p> <p>_____</p> <p>_____</p> <p>TO THE EDUCATIONAL RESOURCES INFORMATION CENTER (ERIC)</p>
--

1

Level 1

Check here for Level 1 release, permitting reproduction and dissemination in microfiche or other ERIC archival media (e.g., electronic) and paper copy.

The sample sticker shown below will be affixed to all Level 2A documents

<p>PERMISSION TO REPRODUCE AND DISSEMINATE THIS MATERIAL IN MICROFICHE, AND IN ELECTRONIC MEDIA FOR ERIC COLLECTION SUBSCRIBERS ONLY, HAS BEEN GRANTED BY</p> <p>_____</p> <p>_____</p> <p>TO THE EDUCATIONAL RESOURCES INFORMATION CENTER (ERIC)</p>
---

2A

Level 2A

Check here for Level 2A release, permitting reproduction and dissemination in microfiche and in electronic media for ERIC archival collection subscribers only

The sample sticker shown below will be affixed to all Level 2B documents

<p>PERMISSION TO REPRODUCE AND DISSEMINATE THIS MATERIAL IN MICROFICHE ONLY HAS BEEN GRANTED BY</p> <p>_____</p> <p>_____</p> <p>TO THE EDUCATIONAL RESOURCES INFORMATION CENTER (ERIC)</p>
---

2B

Level 2B

Check here for Level 2B release, permitting reproduction and dissemination in microfiche only

Documents will be processed as indicated provided reproduction quality permits. If permission to reproduce is granted, but no box is checked, documents will be processed at Level 1.

I hereby grant to the Educational Resources Information Center (ERIC) nonexclusive permission to reproduce and disseminate this document as indicated above. Reproduction from the ERIC microfiche or electronic media by persons other than ERIC employees and its system contractors requires permission from the copyright holder. Exception is made for non-profit reproduction by libraries and other service agencies to satisfy information needs of educators in response to discrete inquiries.

Sign here, please

Signature: <i>Lena Ballone</i>	Printed Name/Position/Title: Lena Ballone, Assistant Professor		
Organizational Address: Bowling Green State Univ Bowling Green, OH 43403	Telephone: 419-372-9410	FAX: 419-372-7291	Date: 4/9/02
	E-Mail Address: ballone@bgsu.net		

bgsu.edu

### III. DOCUMENT AVAILABILITY INFORMATION (FROM NON-ERIC SOURCE):

If permission to reproduce is not granted to ERIC, or, if you wish ERIC to cite the availability of the document from another source, please provide the following information regarding the availability of the document. (ERIC will not announce a document unless it is publicly available, and a dependable source can be specified. Contributors should also be aware that ERIC selection criteria are significantly more stringent for documents that cannot be made available through EDRS.)

Publisher/Distributor:
Address:
Price:

### IV. REFERRAL OF ERIC TO COPYRIGHT/REPRODUCTION RIGHTS HOLDER:

If the right to grant this reproduction release is held by someone other than the addressee, please provide the appropriate name and address:

Name:
Address:

### V. WHERE TO SEND THIS FORM:

Send this form to the following ERIC Clearinghouse:  ERIC/CSMEE 1929 Kenny Road Columbus, OH 43210-1080 E-mail: <a href="mailto:beckrum.1@osu.edu">beckrum.1@osu.edu</a> FAX: 614-292-0263
--