

R E P O R T R E S U M E S

ED 018 662

VT 005 003

PROGRAMMING EXERCISES FOR COMPUTER AIDED DRAFTING (TITLE
SUPPLIED).

MIAMI-DADE JUNIOR COLL., FLA.

PUB DATE 67

EDRS PRICE MF-\$0.50 HC-\$4.92 121P.

DESCRIPTORS- *SUMMER INSTITUTES, *COMPUTER ASSISTED
INSTRUCTION, COMPUTER PROGRAMS, *DRAFTING, *ENGINEERING
DRAWING, PROGRAMING, TEACHER EDUCATION, *INSTRUCTIONAL
MATERIALS, CURRICULUM GUIDES,

REFERENCE MATERIAL AND PROGRAMING EXERCISES USED FOR THE
COMPUTER AIDED DRAFTING SUMMER INSTITUTE AT MIAMI-DADE JUNIOR
COLLEGE, JULY 10-28, 1967, ARE PRESENTED. THE EXERCISES, TO
BE PROGRAMED FOR EXECUTION ON THE IBM SYSTEM 1620 WITH AN
ON-LINE 1627 PLOTTER, PROVIDE A MEDIUM FOR COVERING AND
ENFORCING THE SUBJECT MATERIAL. ALSO INCLUDED ARE (1) THE
SUMMER INSTITUTE SCHEDULE, (2) OUTLINES OF SUBJECT MATERIAL
FOR LABORATORY LECTURES, DRAFTING LANGUAGE, NUMERIC CONTROL,
AND COORDINATE GEOMETRY LANGUAGE, AND (3) A LIST OF 36
PARTICIPANTS. THE FINAL REPORT OF THE INSTITUTE IS VT 004
482. (PS)

ED018662



U.S. DEPARTMENT OF HEALTH, EDUCATION & WELFARE
OFFICE OF EDUCATION

THIS DOCUMENT HAS BEEN REPRODUCED EXACTLY AS RECEIVED FROM THE
PERSON OR ORGANIZATION ORIGINATING IT. POINTS OF VIEW OR OPINIONS
STATED DO NOT NECESSARILY REPRESENT OFFICIAL OFFICE OF EDUCATION
POSITION OR POLICY.

1967 SUMMER INSTITUTE

MIAMI-DADE JUNIOR COLLEGE

Planning & Support of Summer Institute and Drafting
of the Support Job

VT005003



PREFACE

This notebook contains the reference material and programming exercises used for the Computer Aided Drafting Summer Institute at Miami-Dade Junior College, July 10-28, 1967.

The exercises are to be programmed for execution on the IBM System 1620 with an on-line 1627 plotter. The exercises provide a medium for covering and enforcing the subject material.

Each participant in the Summer Institute will receive the programmed solutions for the 1620 and the output from the 1627 for the exercises in this notebook. The programs are not necessarily the most efficient and practical solutions to the exercises. These programs attempt to include only that portion of the subject material familiar to the participant and in sequence with the class lecture.

Bruce L. DeSautel

PARTICIPANTS

STATE	SCHOOL	CITY
<u>ALABAMA</u> Skinner	W. L. Yancey State Junior College	Bay Minette
<u>CALIFORNIA</u> Auerbach Gerevas Gonzalez James McVicar Peck	Sacramento City College Napa Junior College Glendale College Fullerton Junior College Laney College American River College	Sacramento Vallejo Glendale Fullerton Oakland Sacramento
<u>CONNECTICUT</u> Bradshaw	Hartford State Technical Institute	Hartford
<u>FLORIDA</u> Feldman Green Myers Sitz	Hialeah High School Monroe High School Satellite High School New River High School	Miami Cocoa Satellite Beach Ft. Lauderdale
<u>GEORGIA</u> Stewart	Upson County Area Vocational	Thomaston
<u>ILLINOIS</u> Marks	Highland Junior College	Freeport
<u>IOWA</u> Druart	Des Moines Technical High School	Des Moines
<u>MAINE</u> Libby Vassar	Portland High School Central Maine Vocational Technical Institute	Portland Auburn
<u>MASSACHUSETTS</u> Levesque	Taunton High School	Taunton
<u>MINNESOTA</u> Steen	Duluth Area Institute of Technology	Duluth
<u>NEW YORK</u> Grossman Mueller	Alex Hamilton Voc & Tech High School New York City Community College	Queens Brooklyn
<u>OHIO</u> Isbell	Lorraine County Community College	Elyria
<u>OKLAHOMA</u> Rutledge	Area Vocational-Technical Center	Duncan

PARTICIPANTS
(cont.)

STATE	SCHOOL	CITY
<u>PENNSYLVANIA</u>		
Graves	The Williamsport Area Community College	Williamsport
McQuay	The Williamsport Area Community College	Williamsport
<u>RHODE ISLAND</u>		
Anderson	Pilgrim High School	Warwick
Amend	Warwick Veterans High School	Warwick
Ross	Rhode Island Junior College	Providence
Stafford	Rhode Island Junior College	Providence
Zannini	Roger Williams Junior College	Providence
<u>TEXAS</u>		
Bennett	Kilgore College	Kilgore
Potter	Henderson County Junior College	Athens
<u>UTAH</u>		
Schnirel	Utah Technical College	Salt Lake City
<u>VERMONT</u>		
Given	Rutland Senior High School	Rutland
<u>WASHINGTON</u>		
Putas	Lower Columbia College	Longview
Steele	Spokane Community College	Spokane

1 9 6 7 S U M M E R I N S T I T U T E
S C H E D U L E

F I R S T W E E K

	TOPIC	LECTURER	ROOM
MUNDAY JULY 10, 1967			
8.00- 9.00 A.M.	REGISTRATION		3101
9.00-10.30 A.M.	PRESIDING	DR. G. MEHALLIS DIRECTOR, DIV. OF TECH. VOC. AND SEMI- PROFESSIONAL STUDIES	3101
	WELCOME	MR. A. GARNER VICE PRESIDENT	
	FACILITIES	MR. T. KOSCHLER VICE PRESIDENT	
	FLORIDA GREETING	MR. R. CALDWELL STATE DEPT. OF ED.	
	INSTITUTE FORMAT	MR. A. MORPHONIUS INSTITUTE COORDINATOR	
10.30-10.45 A.M.	COFFEE BREAK		
10.45-12.00 A.M.	TOUR OF MIAMI-DADE JUNIOR COLLEGE	MR. A. MORPHONIUS MR. W. TRAVERS	
12.00- 1.00 P.M.	LUNCH		
1.00- 4.30 P.M.	INTRO. DATA PROCESS.	MR. B. DESAUTEL	1155

TUESDAY JULY 11, 1967

8.00-10.00 A.M.	DRAFTING LANGUAGE	MR. B. DESAUTEL	1155
10.00-12.00 A.M.	LABORATORY, GROUP A LABORATORY, GROUP B	ASSISTANTS ASSISTANTS	1164 1155
12.00- 1.00 P.M.	LUNCH		
1.00- 2.00 P.M.	DRAFTING LANGUAGE	MR. B. DESAUTEL	1155
2.00- 4.00 P.M.	LABORATORY, GROUP A LABORATORY, GROUP B	ASSISTANTS ASSISTANTS	1155 1164
4.00- 4.30 P.M.	OPEN LABORATORY	ASSISTANTS	1164

	TOPIC	LECTURER	ROOM
WEDNESDAY JULY 12, 1967			
8.00-10.00 A.M.	DRAFTING LANGUAGE	MR. B. DESAUTEL	1155
10.00-12.00 A.M.	LABORATORY, GROUP A	ASSISTANTS	1164
	LABORATORY, GROUP B	ASSISTANTS	1155
12.00- 1.00 P.M.	LUNCH		
1.00- 2.00 P.M.	AIDS PROJECT .	MR. C. SMITH IBM SYSTEMS ENGINEER MIAMI, FLORIDA	3101
2.00- 4.00 P.M.	LABORATORY, GROUP A	ASSISTANTS	1155
	LABORATORY, GROUP B	ASSISTANTS	1164
4.00- 4.30 P.M.	OPEN LABORATORY	ASSISTANTS	1164

THURSDAY JULY 13, 1967			
8.00-10.00 A.M.	DRAFTING LANGUAGE	MR. B. DESAUTEL	1155
10.00-12.00 A.M.	LABORATORY, GROUP A	ASSISTANTS	1164
	LABORATORY, GROUP B	ASSISTANTS	1155
12.00- 1.00 P.M.	LUNCH		
1.00- 4.30 P.M.	FIELD TRIP MILGO ELECTRONIC CORP. MIAMI, FLORIDA	MR. M. MC HUGH PERSONNEL MANAGER MR. H. THORSEN MARKETING MANAGER	
	AUTOMATED BUILDING COMP. MIAMI, FLORIDA	MR. D. KARSH COMPUTER SYSTEMS ENGR.	

FRIDAY JULY 14, 1967			
8.00- 9.00 A.M.	DRAFTING LANGUAGE	MR. B. DESAUTEL	1155
9.00-10.30 A.M.	ENGR. DATA MANAGEMENT	MR. A. LFEO THE MARTIN COMPANY ORLANDO, FLORIDA	2151
10.30-12.00 P.M.	DRAFTING LANGUAGE	MR. B. DESAUTEL	1155
12.00- 1.00 P.M.	LUNCH		

	TOPIC	LECTURER	ROOM
1.00- 4.00 P.M.	GRAPHIC SCIENCE	MR. N. MICHELSON SPECIAL REP. IBM CORPORATION POUGHKEEPSIE, N.Y.	2151
4.00- 4.30 P.M.	LABORATORY, GROUP A	ASSISTANTS	1155
	LABORATORY, GROUP B	ASSISTANTS	1164

S E C O N D W E E K

MONDAY JULY 17, 1967

8.00-10.00 A.M.	DRAFTING LANGUAGE	MR. B. DESAUTEL	1155
10.00-12.00 A.M.	LABORATORY, GROUP A	ASSISTANTS	1164
	LABORATORY, GROUP B	ASSISTANTS	1155
12.00- 1.00 P.M.	LUNCH		
1.00- 2.00 P.M.	DRAFTING LANGUAGE	MR. B. DESAUTEL	1155
2.00- 4.00 P.M.	LABORATORY, GROUP A	ASSISTANTS	1155
	LABORATORY, GROUP B	ASSISTANTS	1164
4.00- 4.30 P.M.	OPEN LABORATORY	ASSISTANTS	1164

TUESDAY JULY 18, 1967

8.00-10.00 A.M.	DRAFTING LANGUAGE	MR. B. DESAUTEL	1155
10.00-12.00 A.M.	LABORATORY, GROUP A	ASSISTANTS	1164
	LABORATORY, GROUP B	ASSISTANTS	1155
12.00- 1.00 P.M.	LUNCH		
1.00- 2.00 P.M.	DRAFTING LANGUAGE	MR. B. DESAUTEL	1155
2.00- 4.00 P.M.	LABORATORY, GROUP A	ASSISTANTS	1155
	LABORATORY, GROUP B	ASSISTANTS	1164
4.00- 4.30 P.M.	OPEN LABORATORY	ASSISTANTS	1164

WEDNESDAY JULY 19, 1967

8.00-10.00 A.M.	DRAFTING LANGUAGE	MR. B. DESAUTEL	1155
10.00-12.00 A.M.	LABORATORY, GROUP A	ASSISTANTS	1164
	LABORATORY, GROUP B	ASSISTANTS	1155
12.00- 1.00 P.M.	LUNCH		

	TOPIC	LECTURER	ROOM
1.00- 2.30 P.M.	STROMBERG-CARLSON CORPORATION	MR. D. LANDRY DISTRICT MANAGER MR. J. PIRKLF SYSTEM REP.	3101
2.30- 4.30 P.M.	LABORATORY, GROUP A	ASSISTANTS	1155
	LABORATORY, GROUP B	ASSISTANTS	1164

THURSDAY JULY 20, 1967

8.00-10.00 A.M.	DRAFTING LANGUAGE	MR. B. DESAUTEL	1155
10.00-12.00 A.M.	LABORATORY, GROUP A	ASSISTANTS	1164
	LABORATORY, GROUP B	ASSISTANTS	1155
12.00- 1.00 P.M.	LUNCH		
1.00- 2.00 P.M.	DRAFTING LANGUAGE	MR. B. DESAUTEL	1155
2.00- 4.00 P.M.	LABORATORY, GROUP A	ASSISTANTS	1155
	LABORATORY, GROUP B	ASSISTANTS	1164
4.00- 4.30 P.M.	OPEN LABORATORY	ASSISTANTS	1164

FRIDAY JULY 21, 1967

8.00-10.00 A.M.	REVIEW OF DRAFTING LANG.	MR. B. DESAUTEL	1155
10.00- 2.00 P.M.	OPEN LABORATORY	ASSISTANTS	1164
12.00- 1.00 P.M.	LUNCH		
1.00- 4.30 P.M.	FIELD TRIP INST. OF MARINE SCIENCE UNIVERSITY OF MIAMI	DR. F. SMITH DIRECTOR MR. D. SHAFFFR MANAGER COMP. CENTER	

T H I R D W E E K

MONDAY JULY 24, 1967

8.00-11.00 A.M.	LECTURE NUMERIC CONTROL	MR. J. CORBIN	1155
11.00-12.00 A.M.	COMPUDYNE CORPORATION	MR. J. SMITH DIST. SALES ENGR. HATBORO, PA.	3101
12.00- 1.00 P.M.	LUNCH		

	TOPIC	LECTURER	ROOM
	1.00- 4.30 P.M. LABORATORY		3117

TUESDAY JULY 25, 1967			
	8.00-12.00 A.M. LECTURE NUMERIC CONTROL	MR. A. POH	1155
	12.00- 1.00 P.M. LUNCH		
	1.00- 4.30 A.M. LECTURE COGO	MR. B. DESAUTEL	1155

WEDNESDAY JULY 26, 1967			
	8.00-10.00 A.M. LECTURE COGO	MR. B. DESAUTEL	1155
	10.00-12.00 A.M. LABORATORY, GROUP A	ASSISTANTS	1164
	LABORATORY, GROUP B	ASSISTANTS	1155
	12.00- 1.00 P.M. LUNCH		
	1.00- 2.00 P.M. LECTURE COGO	MR. B. DESAUTEL	1155
	2.00- 4.00 P.M. LABORATORY, GROUP A	ASSISTANTS	1155
	LABORATORY, GROUP B	ASSISTANTS	1164
	4.00- 4.30 P.M. OPEN LABORATORY	ASSISTANTS	1164

THURSDAY JULY 27, 1967			
	8.00-10.00 A.M. LECTURE COGO	MR. B. DESAUTEL	1155
	10.00-12.00 A.M. LABORATORY, GROUP A	ASSISTANTS	1164
	LABORATORY, GROUP B	ASSISTANTS	1155
	12.00- 1.00 P.M. LUNCH		
	1.00- 2.00 P.M. LECTURE COGO	MR. B. DESAUTEL	1155
	2.00- 4.00 P.M. LABORATORY, GROUP A	ASSISTANTS	1155
	LABORATORY, GROUP B	ASSISTANTS	1164
	4.00- 4.30 P.M. OPEN LABORATORY	ASSISTANTS	1164

FRIDAY JULY 28, 1967			
	8.00-10.00 A.M. LECTURE COGO	MR. B. DESAUTEL	1155
	10.00-12.00 A.M. OPEN LABORATORY	ASSISTANTS	1164
	12.00- 1.30 P.M. PRESIDENTS LUNCHEON	DR. P. MASIKO PRESIDENT	1324

	TOPIC	LECTURER	ROOM
1.30- 4.30 P.M.	SUMMER INSTITUTE REVIEW	MR. B. DESAUTEL	1155

NOTES,

1. ASSISTANTS MR. L. ROSE
 MR. R. MACFARLANE
 MR. W. THOMPSON

2. ROOM 1164-IBM SYSTEM 1620

1 9 6 7 S U M M E R I N S T I T U T E
LABORATORY ASSIGNMENTS

NAME	GROUP	TEAM
AMEND	A	5
ANDERSON	B	6
AUERBACH	B	1
BENNETT	A	5
BRADSHAW	B	2
DRUART	B	3
FELDMAN	A	2
GEREVAS	B	1
GIVEN	A	6
GONZALEZ	A	1
GRAVES	A	4
GREEN	A	2
GROSSMAN	A	4
ISBELL	A	4
JAMES	A	1
LEVESQUE	A	3
LIBBY	A	3
MARKS	A	3
MC QUAY	B	4
MC VICAR	B	1
MUELLER	B	4
MYERS	B	2
PAPPAS	B	6
PECK	A	2
POTTER	B	5
PUTAS	B	6
ROSS	B	5
RUTLEDGE	B	4
SCHNIREL	A	6
SKINNER	A	6
STAFFORD	A	5
STEELE	B	6
STEEN	B	3
STEWART	B	2
VASSER	B	3
ZANNINI	B	5

1 9 6 7 S U M M E R I N S T I T U T E
LABORATORY ASSIGNMENTS

NAME	GROUP	TEAM
AMEND	A	5
ANDERSON	B	6
AUERBACH	B	1
BENNETT	A	5
BRADSHAW	B	2
DRUART	B	3
FELDMAN	A	2
GEREVAS	B	1
GIVEN	A	6
GONZALEZ	A	1
GRAVES	A	4
GREEN	A	2
GROSSMAN	A	4
ISBELL	A	4
JAMES	A	1
LEVESQUE	A	3
LIBBY	A	3
MARKS	A	3
MC QUAY	B	4
MC VICAR	B	1
MUELLER	B	4
MYERS	B	2
PAPPAS	B	6
PECK	A	2
POTTER	B	5
PUTAS	B	6
ROSS	B	5
RUTLEDGE	B	4
SCHNIREL	A	6
SKINNER	A	6
STAFFORD	A	5
STEELE	B	6
STEEN	B	3
STEWART	B	2
VASSER	B	3
ZANNINI	B	5

1 9 6 7 S U M M E R I N S T I T U T E
SUBJECT MATERIAL FOR LABORATORY LECTURES

I LABORATORY LECTURE 1

- A. HARDWARE CONTAINED IN THE SYSTEM 1620 LABORATORY
 - 1. 1620 CENTRAL PROCESSING UNIT AND CONSOLE
 - 2. 1623 CORE STORAGE
 - 3. 1627 PLOTTER
 - 4. 1311 DISC STORAGE
 - 5. 1622 CARD READ PUNCH
 - 6. 1443 PRINTER
 - 7. 026 CARD PUNCH

- B. PRINCIPLES OF STORED PROGRAM OPERATION
 - 1. STORAGE AND RETRIEVAL OF DATA
 - 2. PROGRAMS—A SPECIAL KIND OF DATA

- C. LANGUAGES IN WHICH PROGRAMS ARE WRITTEN
 - 1. MACHINE OR OBJECT LANGUAGE
 - 2. ASSEMBLY LANGUAGE
 - 3. FORTRAN
 - 4. DRAFTING LANGUAGE
 - 5. COGO

- D. DEMONSTRATION
 - 1. A MACHINE LANGUAGE DRAWING USING THE PLOTTER
 - 2. A FORTRAN-II PROGRAM
 - 3. A DRAFTING LANGUAGE PROGRAM

II LABORATORY LECTURE 2

- A. OPERATION OF THE 026 PRINTING CARD PUNCH
 - 1. ALPHABETIC MODE
 - 2. NUMERIC MODE
 - 3. CARD CONTROL

- B. OPERATION OF THE 1620 CONSOLE
 - 1. MANUAL AND AUTOMATIC MODES
 - 2. START AND STOP KEYS
 - 3. SIGNAL LIGHTS
 - 4. INPUT AND OUTPUT FROM THE CONSOLE TYPEWRITER

- C. OPERATION OF THE 1622 READER
 - 1. INSERTION OF PUNCHED CARDS
 - 2. LOADING A PROGRAM
 - 3. USE OF THE START BUTTON
 - 4. NONPROCESS RUNOUT
 - 5. READER LIGHTS

- D. OPERATION OF THE 1443 PRINTER
 - 1. START AND STOP KEYS
 - 2. CARRIAGE CONTROL

E. OPERATION OF THE 1627 PLOTTER

1. RAISING AND LOWERING THE DRAWING PEN
2. MOVEMENT OF THE PEN AND DRUM DURING DRAWING
3. GROSS AND FINE ADJUSTMENT OF THE PEN POSITION
4. PLACING AND REMOVAL OF PAPER FOR DRAWINGS

F. FUNCTION OF THE 1311 DISC UNIT

1. RANDOM ACCESS STORAGE
2. INTERMEDIATE STORAGE

1 9 6 7 S U M M E R I N S T I T U T E
S U B J E C T M A T E R I A L F O R D R A F T I N G L A N G U A G E

I INTRODUCTION

II ORIENTATION

- A. CLASS OUTLINE
- B. STUDENT NOTEBOOKS
- C. LABORATORIES

III INTRODUCTION TO DATA PROCESSING

- A. HISTORY
- B. EVOLUTION OF COMPUTERS
- C. 1620 MACHINE LANGUAGE
 - 1. INSTRUCTIONS
 - 2. ADDRESSES
 - 3. LOGIC
 - 4. ARITHMETIC
- D. PRODUCING A PROGRAM

IV PROCEDURE FOR PRODUCING A PROGRAM

V DRAFTING LANGUAGE PROCESSORS

- A. COMPILER
- B. PART PROCESSOR
- C. DRAWING PROCESSOR

VI PARTS OF A DRAFTING LANGUAGE PROGRAM

- A. GEOMETRIC GROUPS
 - 1. VIEW
 - 2. SHAPE
 - 3. END
- B. OBJECT LINES
- C. DRAWING STATEMENTS
 - 1. SCALE
 - 2. ORIGIN
 - 3. DRAW

VII LANGUAGE FORMAT AND CODING

- A. LANGUAGE WORDS
 - 1. MAJOR
 - 2. MODAL
- B. USER-CREATED WORDS
 - 1. NUMBERS
 - 2. LABELS
- C. PUNCTUATION
 - 1. COMMA
 - 2. EQUAL
 - 3. SLASH
 - 4. PLUS-MINUS

- 5. DOLLAR SIGN
- 6. BLANK

D. LINE CLASSIFICATION

- 1. MEDIUM
- 2. THICK

VIII POINTS

A. INTRODUCTION

- 1. RECTANGULAR COORDINATES
- 2. PPP

IX LINES

A. INTRODUCTION

- 1. POINT TO POINT
- 2. RELATIVE DISTANCE
- 3. DISTANCE FROM PPP

X CIRCLES

A. INTRODUCTION

- 1. CENTER POINT AND RADIUS

XI LINES

A. FROM A POINT AT AN ANGLE TO THE X-AXIS

XII LETTERING

A. INTRODUCTION

- 1. ALPHAP
- 2. TITLE
- 3. LITERALS

XIII ARC

A. INTRODUCTION

- 1. BETWEEN TWO POINTS

XIV MACRO

A. INTRODUCTION

- 1. MACRO/
- 2. TERMAC/
- 3. DEFINE PARAMETERS OF A MACRO
- 4. CALL

XV DIMENSIONING

A. INTRODUCTION

- 1. DIMST
- 2. DIMP
- 3. MASK

4. DIM

XVI LINES

- A. DISTANCE FROM PPP
- B. INTERSECTION OF A LINE AND A CIRCLE

XVII CIRCLES

- A. CENTER AND RADIUS OF AN ARC
- B. DEFINED BY THREE POINTS

XVIII ARC

- A. FILLETING

XIX GEOMETRIC FUNCTIONS

- A. DXOF
- B. DYOF
- C. DIST
- D. ATAND
- E. PARAM

XX HATCHING

XXI LOOPING

XXII ARITHMETIC FUCTIONS

- A. INTRODUCTION
 - 1. SIND
 - 2. COSD
 - 3. ATAND
 - 4. SQRT
 - 5. ABS
 - 6. ALOG

1 9 6 7 S U M M E R I N S T I T U T E
S U B J E C T M A T E R I A L - N U M E R I C C O N T R O L

I HISTORY AND DEVELOPMENT

- A. CONCEPTION
- B. DEVELOPMENT
- C. SIMPLIFICATION

II PRESENT APPLICATIONS OF NUMERIC CONTROL

- A. PROCESS CONTROLS
- B. APPLICATION TO MACHINE TOOLS

III MANUAL PROGRAMMING

- A. CODE AND LANGUAGE
- B. POINT TO POINT PROGRAMMING
- C. CONTINUOUS PATH PROGRAMMING

IV LABORATORY WORK

- A. PROBLEM USING POINT TO POINT PROGRAMMING-PRATT AND WHITNEY TAPEOMATIC DRILL
- B. DEMONSTRATION OF CONTINUOUS PATH MILLING OPERATIONS-COMPUDYNE 3 AXIS CONTINUOUS PATH MILLING MACHINE

SUBJECT MATERIAL-THE COMPUTERS ROLE IN NUMERICAL CONTROL

V INTRODUCTION

- A. THE PART PROGRAMMER
- B. PROGRAMMING FOR POINT TO POINT POSITIONING
- C. PROGRAMMING FOR CONTOUR MACHINING
- D. PROGRAM CHECKING-TAPE VERIFICATION
- E. PROGRAMMING LANGUAGE
- F. DESIGN AUTOMATION

VI INFORMATION PROCESSING AND STORAGE

VII THE AUTOSPOT II SYSTEM

- A. GENERAL APPLICATION DESCRIPTION
 - 1. SAMPLE PROGRAM
 - 2. THE AUTOSPOT II LANGUAGE
 - 3. VOCABULARY AND STATEMENTS
 - 4. PROCESSOR ORGANIZATION
- B. POINT TO POINT AUTOSPOT II PROGRAMMING
 - 1. DEFINITION STATEMENTS
 - 2. MACHING STATEMENTS
 - 3. SPECIAL STATEMENTS
 - 4. PUNCTUATION
 - 5. OPERATIONS

- 6. PATTERNS
- 7. ROUTINES
- C. NUMERIC CONTROL LABORATORY
 - 1. PROCESSOR OPERATION
 - 2. TOOL OPERATION

1 9 6 7 S U M M E R I N S T I T U T E
SUBJECT MATERIAL FOR THE COORDINATE GEOMETRY LANGUAGE

- I PURPOSE
- II COORDINATE TABLE
- III ACCURACY
- IV CODING INSTRUCTIONS
 - A. COMMAND NAME
 - B. DATA
 - C. DITTO FEATURE
 - D. COMMENTS
- V LANGUAGE CONVENTIONS
 - A. ANGLES AND AZIMUTHS
 - B. BEARINGS
 - C. MEASUREMENT OF ANGLES
- VI NON-COMPUTATIONAL INSTRUCTIONS
 - A. CLEAR
 - B. STORE
 - C. DUMP
 - D. PAUSE
- VII INSTRUCTIONS
 - A. LOCATE
 - B. INVERSE
 - C. ANGLE
 - D. DISTANCE
 - E. PARALLEL/LINE
 - F. INTERSECT
 - G. AREA
 - 1. POLYGON
 - 2. SEGMENTS
- VIII TRIANGULATION
- IX TRAVERSE ADJUSTMENT
- X ARC
- XI TANGENT
- XII CURVES
 - A. ALIGNMENT
 - B. OFFSETS
- XIII DIVIDING LINE
- XIV GIRDER LENGTHS

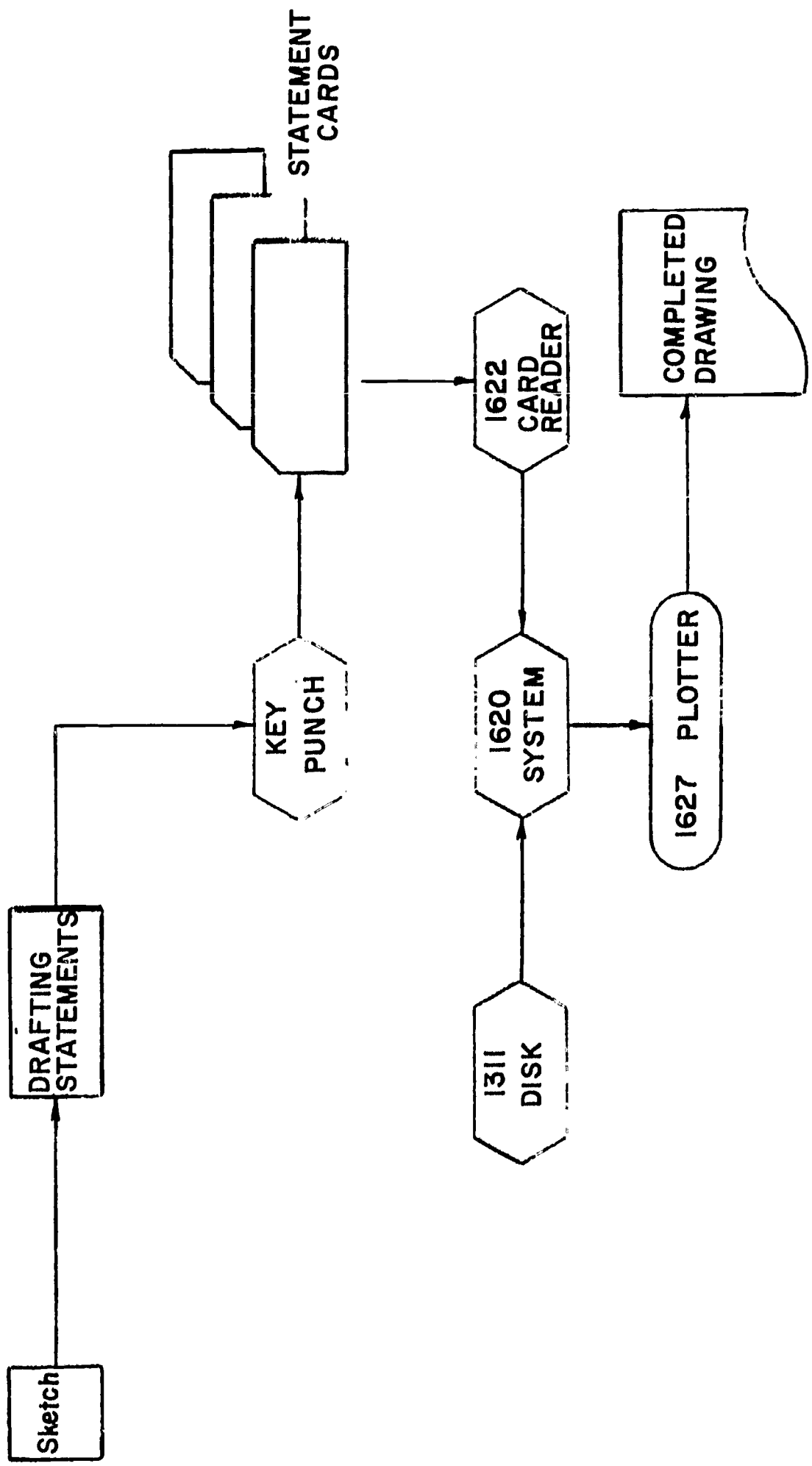

PROCEDURE FOR PRODUCING A DRAWING

DRAFTING CONTROL CARDS

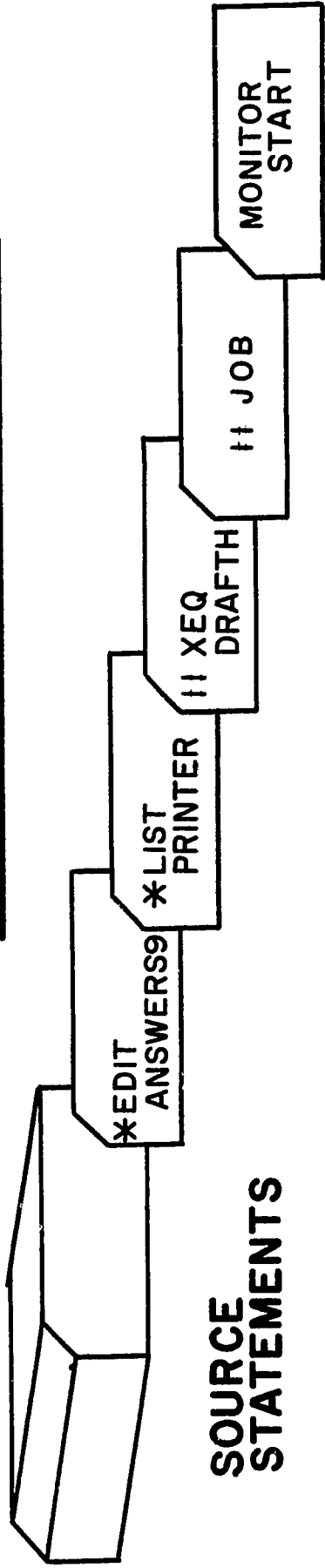

MONITOR CONTROL CARDS

STACKED JOB INPUT

DRAFTING LANGUAGE

1967 SUMMER INSTITUTE
MIAMI-DADE JUNIOR COLLEGE
DRAFTING LANGUAGE

Exercise 1

Draw Sketch 1 using the following specifications:

1. Paper Size $8\frac{1}{2}$ x 11,
2. Thick border $\frac{1}{2}$ inch from the paper edge except on the left which shall have a $1\frac{1}{2}$ inch border,
3. A $\frac{3}{4}$ inch title block on the bottom with the note 'INTRODUCTION TO LINES',
4. Place the note, 'PLATE 1' in the lower right corner above the title block,
5. When writing the program use the mirror geometric function,
6. Place the Part Origin at 4.75 and 6.00.

Exercise 2

Draw Sketch 2 using the paper size and border as given in Exercise 1 and include the following specifications:

1. In the title block write the note, 'INTRODUCTION TO CIRCLES',
2. Write the note, 'PLATE 2'

Exercise 3

Exercise 3 is a demonstration of writing notes using the Drafting Language.

Exercise 4

Draw Sketch 4 using the paper size and border as given in Exercise 1 and include the following specifications:

1. Scale = 2,
2. Title, 'PICTURE AND FRAME'.

Exercise 5

Draw Sketch 5 using the paper size and border as given in Exercise 1 and include the following specifications:

1. The paper and part origin are at the same point,
2. Draw the plate so that the part is along the X-axis,
3. Do not draw the slot,
4. Note that distance KA is unknown,
5. Title, 'SHEAR PLATE'.



Exercise 6

Draw Sketch 6 using the paper size and border as given in Exercise 1 and include the following specifications:

1. Scale = $3/4$
2. Origin, 4.75, 6,
3. Draw the object lines of the base only,
4. Title, 'FIXTURE BASE'.

Exercise 7

Draw Sketch 7 as a Macro for a $8\frac{1}{2}$ x 11 sheet of paper using the following specifications:

1. The title will always be on the bottom,
2. The X axis is either the short or long dimension of the paper,
3. The border is a thick line.

NOTE: ALL EXERCISES SHALL BE DRAWN USING THIS MACRO.

Exercise 8

Draw Sketch 8 using the Macro developed in Exercise 7 using the following specifications:

1. Scale = 2,
2. Origin, 2.5, 4, lower left corner of part;
3. Dimension all object lines and notice that one line has an unknown dimension.

Exercise 9

Use Plate 5 as a base and add the following specifications to draw Plate 9:

1. Draw the slot and center lines,
2. Dimension the arcs KJH, JHG, HGF and GFE.

Exercise 10

Use Plate 6 as a base and add the following specifications to draw Plate 10:

1. Draw the slot and center lines,
2. Draw the circles,
3. Dimension the slot width and height,
4. Dimension the base height and vertical dimension between large circles.

Exercise 11

Draw Sketch 11 using the following specifications:

1. Origin, 4.75, 6 at center of gasket,
2. Dimension one of the six holes, the 7/8" radius,
3. Dimension the angles between the three holes at the bottom.

Exercise 12

Draw Sketch 12 using the following specifications:

1. Use the EDIT ANSWERS9 control card to determine the unknown distance,
2. Use the COSD and SIND arithmetic functions for solving the unknown height,
3. Side view origin, 2.25, 2.25, lower left corner,
4. Front view origin 17., 2.25, lower left corner,
5. Draw the plate so that the part is along the X-axis,
6. Dimension the base of the side view,
7. Dimension the X-component of the slot and dove-tail slot of the front view.

Exercise 13

Draw Sketch 13 using the following specifications:

1. Top view origin, $2.312 + 11/8$, 8., center of circle,
2. Front view origin, $4.687 + 11/8$, 4.125, center of circle,
3. Dimension the X-component of the top arc and hidden lines,
4. Dimension the height in both views.

Exercise 14

Draw Sketch 14 using the following specifications:

1. Scale = .5,
2. Origin, 6.25, 5.5, center of large circle,
3. Dimension the object lines of the side view,
4. Dimension the distance between the circle centers in the front view.

Exercise 15

Draw Sketch 15 using the following specifications:

1. Scale = .5
2. Front view origin, 4.50, 3 11/16,
3. Dimension the following dimensions on the front view; 9/16" vertical, 1 3/8", 1 7/8", and 1 1/8",
4. NOTE Statement in top view Arcs in this slot are 3/8", and the distance between centers is 1.5".

Exercise 16

Draw Sketch 16 using the following specifications:

1. Top view origin, 3.00, 2.1875, low left corner,
2. Side view origin, 7 13/16, 3 3/4, center of circle,
3. Dimension 7/16" on side view,
4. NOTE Statement in top view, "9/32 Drill, CSK 82° x 1/2 DIA.", with the letters at an angle of -15°,
5. NOTE Statements in side view, "1/4 Drill, Bore 1/2 DIA. x 1 7/8 DP" and "5/8 R",
6. Note Statement for Finish Mark,
7. Draws part parallel to X-axis.

Exercise 17

Draw Sketch 17 using the following specifications:

1. Top view origin, 3.75, 5.875, center of cap, all views,
2. Draw cutting plane in top view and section view with hatching,
3. Dimension 2" and 11/16" in section view.

Exercise 18

Draw Sketch 18 using the following specifications:

1. Top view origin, 4.25, 3.75, center of shaft guide,
2. Draw cutting plans in top view and section view with hatching.

Exercise 19

Demonstration

Exercise 20

Draw Sketch 20 using the following specifications:

1. Write a macro to draw the coordinate axis with the following parameters;
 - A. Length of X-axis,
 - B. Length of Y-axis,
 - C. Scale for the X-axis,
 - D. Scale for the Y-axis,
2. Write a macro to draw a bar graph with the following parameters:
 - A. Center of the bar on the X-axis,
 - B. Bar width and height,
 - C. Type of latching,
 - D. Y value as a literal,
 - E. Front of the literal,
 - F. Number of letters in the literal.

Exercise 21

Draw Sketch 21 using the following specifications:

1. Origin, 8.70, 6.5, same origin as shown on the sketch,
2. Dimension the arc centers of the depressions and the length of the part.

1967 SUMMER INSTITUTE
MIAMI-DADE JUNIOR COLLEGE
NUMERICAL CONTROL

Exercise 1

Write a program in machine language for the Pratt-Whitney Tape-o-matic Drilling and Boring Machine to drill the holes as shown in the Autospot Sketch.

Exercise 2

Create the paper tape for the program written in Exercise 1 and execute the program on the Pratt-Whitney Tape-o-matic Drilling and Boring Machine.

Exercise 3

Write a program in Autospot II Language and create the paper tape to drill the holes shown in the Autospot Sketch.

1620 DRAFTING SYSTEM

77 80

MIAMI-DADE JUNIOR COLLEGE

\$ FOR COMMENT

IDENTIFICATION

NO.	LABEL	LINE CLASS	MAJOR WORD	PHRASE	SEQ.
	A LABEL	=		AN EXAMPLE OF A LABEL	
	A 12345	=		FIRST LETTER MUST BE A LETTER (A-Z)	
	A	=		TABLS ARE 1-6 CHARACTERS IN LENGTH	
				AN EXAMPLE OF A LINE CLASS	
				LINE / AN EXAMPLE OF A MAJOR WORD	
				POINT / -123456.78, 1 AN EXAMPLE OF NUMBERS	
				NUMBERS CAN BE UP TO 8 DIGITS	
				THE DECIMAL POINT IS OPTIONAL	
				NEGATIVE NUMBERS MUST BE SIGNED	
				@A LITERAL @ 1-48 CHARACTERS	
				@ NOT PART OF LITERAL	

\$\$ USED TO PLACE COMMENTS AMONG THE PROGRAM STATEMENTS

1) AN EXAMPLE OF A NUMBERED STATEMENT

A R C / BLANKS ARE IGNORED BY THE PROCESSOR

THIS FORM IS FOR PROGRAMMING CONVENIENCE - THE DRAFTING LANGUAGE MAY BE WRITTEN IN FREE FORMAT.

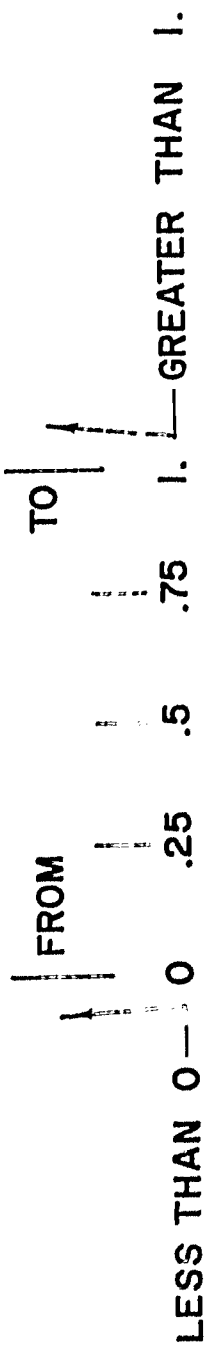

TEXT PLACEMENT

FONT SIZE

DIMP/ 1, 2, 3, 4

FROM ARROW TO ARROW
CODE

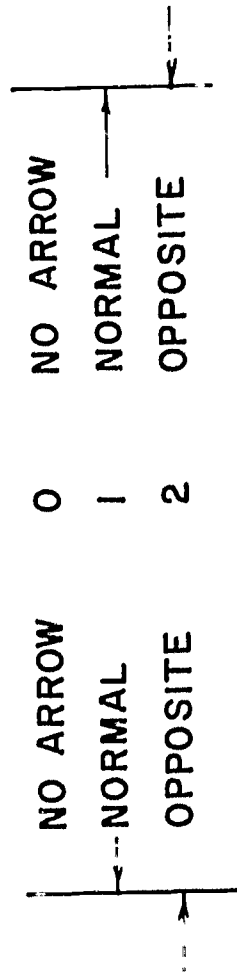

DIMP STATEMENT

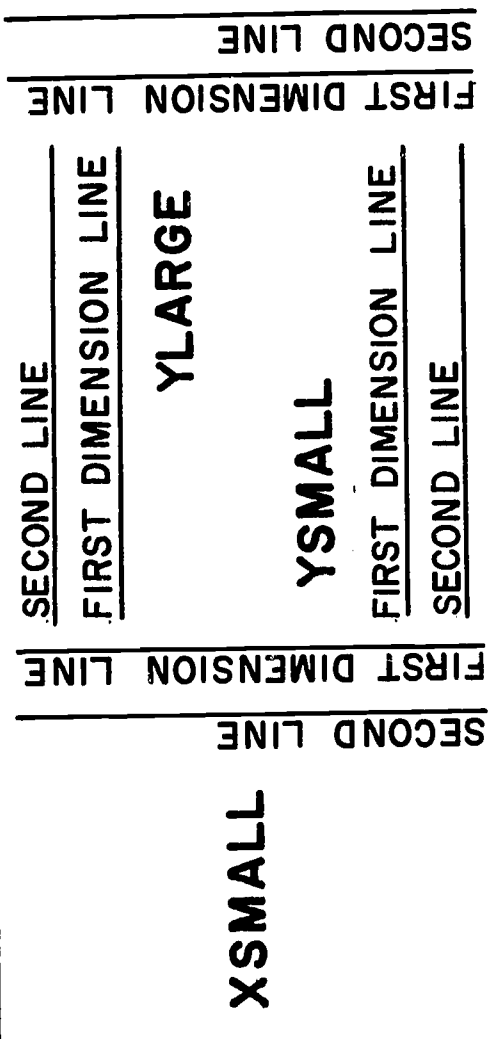

DIRECTION OF INDEXING

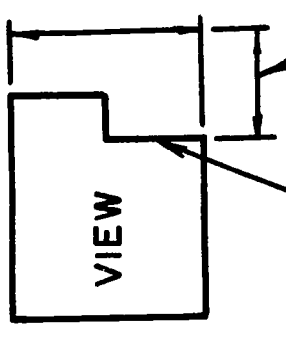

STARTING LINE

DIMST / 1 , 2 , 3 , 4

DISTANCE

TYPE OF INDEXING

INDEX / code

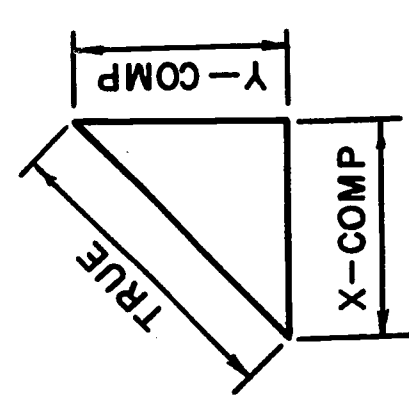

- 1 NO DISTANCE
- +n NUMBER OF LINES TO BE SKIPPED

DIMST AND INDEX STATEMENTS

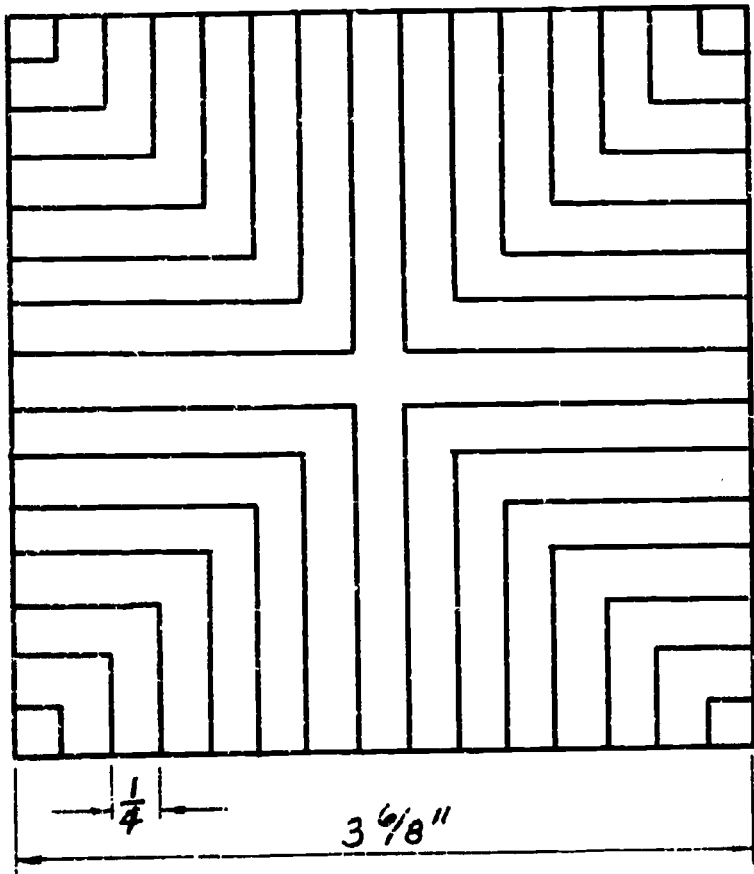

SKETCH 1
1967 SUMMER INSTITUTE

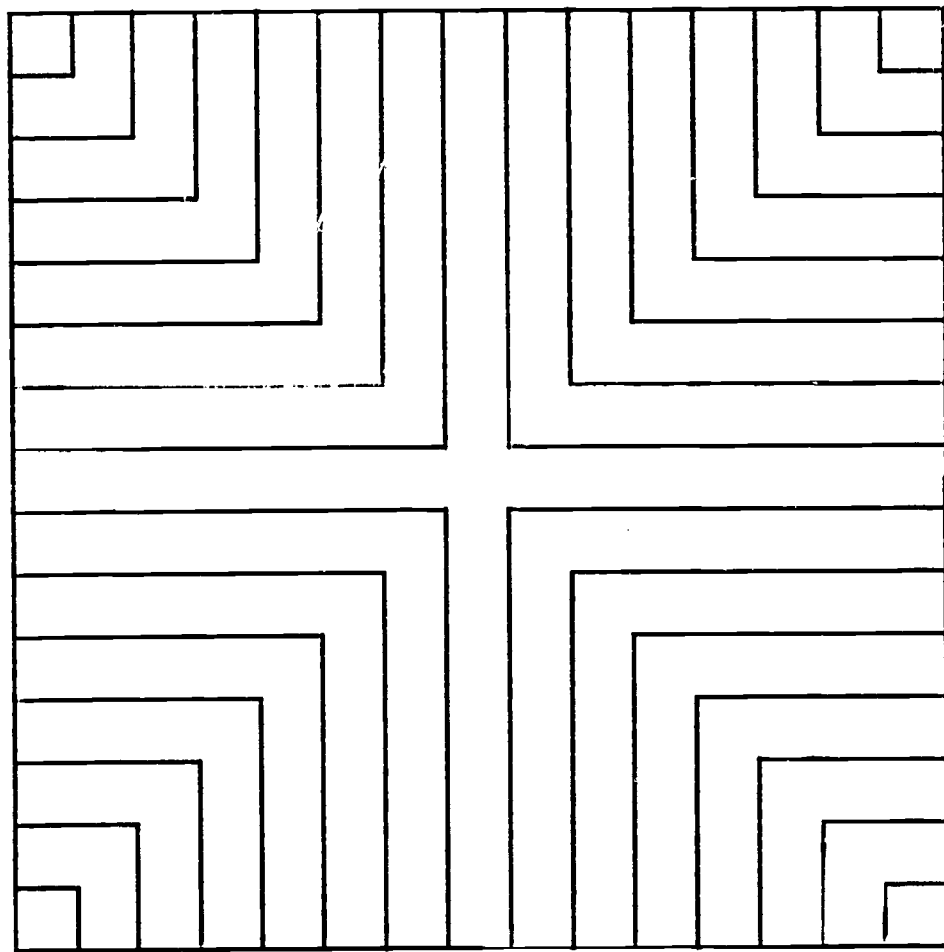
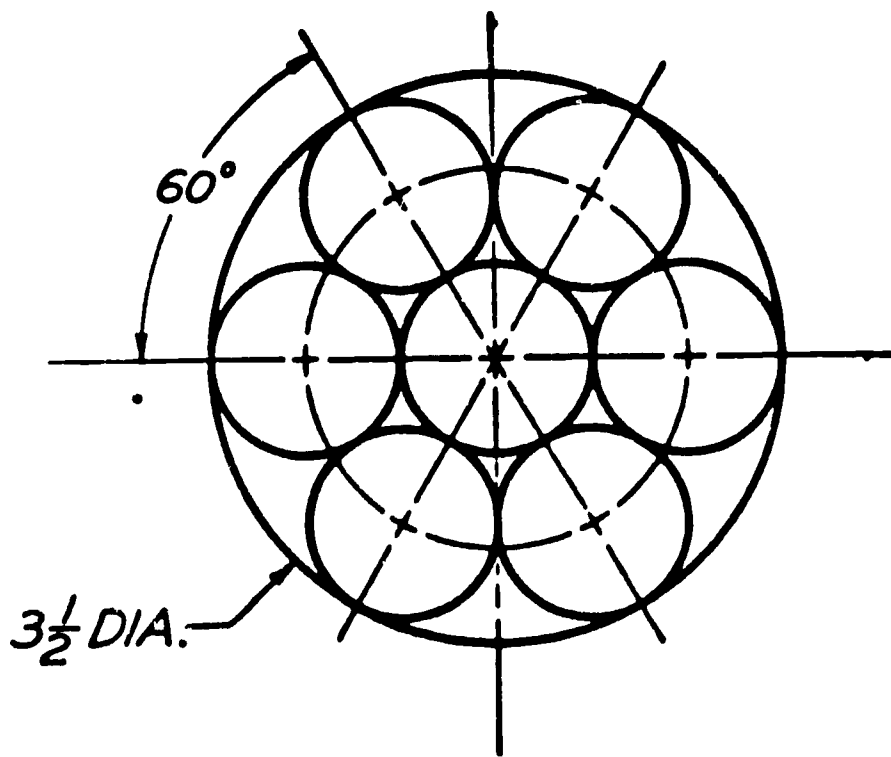

PLATE 1

INTRODUCTION TO LINES

*** 1967 SUMMER INSTITUTE

```
$$ PLATE 1          INTRODUCTION TO LINES
BOX      =THICK ,VIEW /
          LINE /1.5,.5,DX,6.5
          LINE /DY,10
          LINE /DX,-6.5
          LINE /DY,-10
          LINE /1.5,1.25,DX,6.5
          END   /BOX
          DRAW  /BOX
          ALPHAP/(.2,.3,.282,0),(0,0,0,0)
          TITLE/1.6,.875,@ INTRODUCTION TO LINES@
          TITLE /6,1.5,@PLATE 1@
SQUARE = VIEW /
          ORIGIN/4.75,6
          LINE /1+7/8,0,DY,1+7/8
          LINE /DX,-1-7/8
          LINE /1/8,1+7/8,DY,-1-3/4
          LINE /DX,1+3/4
          LINE /1+7/8,3/8,DX,-1-1/2
          LINE /DY,1+1/2
          LINE /5/8,1+7/8,DY,-1-1/4
          LINE /DX,1+1/4
          LINE /1+7/8,7/8,DX,-1
          LINE /DY,1
          LINE /1+1/8,1+7/8,DY,-3/4
          LINE /DX,3/4
          LINE /1+7/8,1+3/8,DX,-1/2
          LINE /DY,1/2
          LINE /1+5/8,1+7/8,DY,-1/4
          LINE /DX,1/4
          END   /SQUARE
          DRAW  /SQUARE
          DRAW  /MIRX(SQUARE)
          DRAW  /MIRY(SQUARE)
          DRAW  /MIRXY(SQUARE)
          FINI  /
```



SKETCH 2
1967 SUMMER INSTITUTE

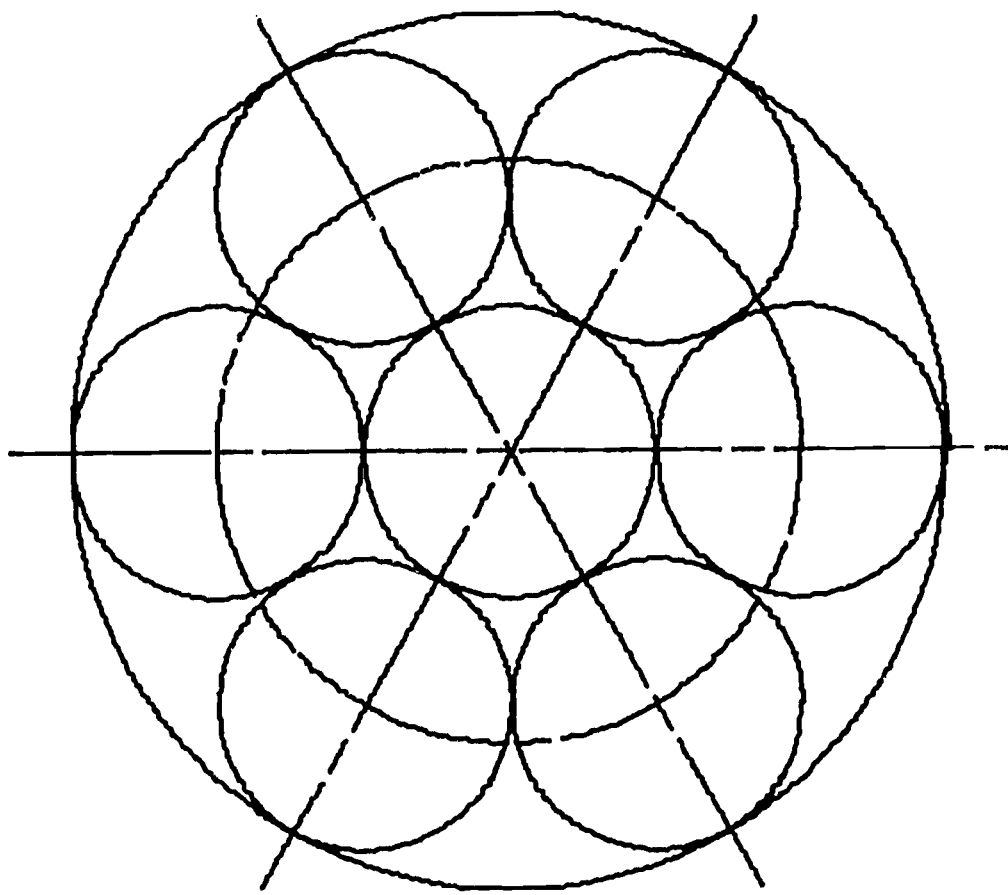

PLATE 2

INTRODUCTION TO CIRCLES

*** 1967 SUMMER INSTITUTE

```
$$ PLATE 2          INTRODUCTION TO CIRCLES
BOX      =THICK ,VIEW /
          LINE /1.5,.5,DX,6.5
          LINE /DY,10
          LINE /DX,-6.5
          LINE /DY,-10
          LINE /1.5,1.25,DX,6.5
          END /BOX
          DRAW /BOX
          ALPHAP/(.2,.3,.26,0),(0,0,0,0)
          TITLE/1.6,.875,@ INTRODUCTION TO CIRCLES@
          ALPHAP/(.2,.2,.2,0),(0,0,0,0)
          TITLE /6,1.5,@PLATE 2@

DESIGN  =          VIEW /
          ORIGIN/4.75,6
          CIRCLE/0,0,1.75

C1      =CTRLN ,CIRCLE/0,0,1.166
L1      =CTRLN ,LINE /-2,0,DX,4
          CONSTR,LINE /0,0,ATANGL,120,LENGTH,2
L2      =CTRLN ,LINE /PPP,ATANGL,300,LENGTH,4
          CONSTR,LINE /0,0,ATANGL,60,LENGTH,2
L3      =CTRLN ,LINE /PPP,ATANGL,240,LENGTH,4
          CIRCLE/(POINT/XSMALL,INTOF,L1,C1),1.166/2
          CIRCLE/(POINT/YLARGE,INTOF,L2,C1),1.166/2
          CIRCLE/(POINT/YLARGE,INTOF,L3,C1),1.166/2
          CIRCLE/1.166,0,1.166/2
          CIRCLE/(POINT/YSMALL,INTOF,L2,C1),1.166/2
          CIRCLE/(POINT/YSMALL,INTOF,L3,C1),1.166/2
          CIRCLE/0,0,1.166/2
          END /DESIGN
          DRAW /DESIGN
          FINI /
```

ABCDEFGG
(.3..3..3.0).(10.0.0.0)

A B C D E F G
(.3..3..5.0).(10.0.0.0)

ABCDEFGG
(.3..3..10.0).(10.0.0.0)

A B C D E F G G F E D C B A
(.3..3..3..2).(10.0.0.0)
(.3..3..5..-2).(10.0.0.0)

ABCDEFGG
(0.6.6.0.0)

ABCDEFGG
(.3..1..3.0).(10.0.0.0)

A B C D E F
(.6..6..6.0).(10.0.0.0)

ABCDE
FGHIJ
KLMNO
(.3..3..3.0).(1.3..-3.0.0)

ABCDE
FGHIJ
(.3..3..3.0).(0..-6.0.0)

NOTES CAN BE
DRAWN WITH
AN ARROW ON
THE RIGHT

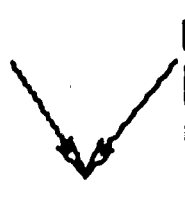

OR THEY CAN
BE DRAWN WITH
AN ARROW ON
THE LEFT

(.2..2..2.0).(10.0.0.0)

PLATE 3

INTRODUCTION TO NOTES

*** 1967 SUMMER INSTITUTE

```

$$ PLATE 3          INTRODUCTION TO NOTES
BOX   =THICK ,VIEW /
LN    /1.5,.5,DX,6.5
LN    /DY,10
LN    /DX,-6.5
LN    /DY,-10
LN    /1.5,1.25,DX,6.5
END   /BOX
DRAW  /BOX
ALPHAP/(.2,.3,.282,0),(0,0,0,0)
TITLE /1.5,.875,@ INTRODUCTION TO NOTES@
ALPHAP/(.2,.2,.2,0),(0,0,0,0)
TITLE/6,1.5,@PLATE 3@
ORIGIN/.39,-.225
ALPHAP/(.3,.3,.3,0),(0,0,0,0)
NOTE  /1.65,10,@ABCDEFGG@
ALPHAP/(.3,.3,.5,0),(0,0,0,0)
NOTE  /4.2,10,@ABCDEFGG@
NOTE  /2.05,8.8,@ABCDEFGG@
ALPHAP/(.3,.3,.3,.2),(0,0,0,0)
NOTE  /3.3,7.6,@ABCDEFGG@
ALPHAP/(.3,.3,.3,-.2),(0,0,0,0)
NOTE  /5.4,8.8,@GFEDCBA@
ALPHAP/(.1,.3,.1,0),(0,0,0,0)
NOTE  /1.65,7.6,@ABCDEFGG@
ALPHAP/(.3,.1,.3,0),(0,0,0,0)
NOTE  /1.65,6.4,@ABCDEFGG@
ALPHAP/(.6,.6,.6,0),(0,0,0,0)
NOTE  /4.2,6.4,@ABCDEF@
ALPHAP/(.3,.3,.3,0),(0.3,-.3,0,0)
NOTE  /1.65,5.2,@ABCDE@,@FGHIJ@,@KLMNO@
ALPHAP/(.3,.3,.3,0),(0,-.6,0,0)
NOTE  /5.0,5.2,@ABCDE@,@FGHIJ@
ALPHAP/(.2,.2,.2,0),(0,-.2,0,0)
NOTER /4.25,2.8,-.35,.55,@NOTES CAN BE@,$
NOTE  /4.25,2.8,.45,.55,@OR THEY CAN@,$
@BE DRAWN WITH@,@AN ARROW ON@,@THE LEFT@
ALPHAP/(.1,.1,.1,0),(0,0,0,0)
NOTE  /1.49,9.75,@(.3,.3,.3,0),(0,0,0,0)@
NOTE  /4.65,9.75,@(.3,.3,.5,0),(0,0,0,0)@
NOTE  /1.5,8.55,@(.3,.3,.18,0),(0,0,0,0)@
NOTE  /4.15,7.8,@(.3,.3,.3,.2),(0,0,0,0)@
NOTE  /4.15,7.55,@(.3,.3,.3,-.2),(0,0,0,0)@
NOTE  /1.5,7.35,@(.1,.3,.1,0),@
NOTE  /1.5,7.25,@(0,0,0,0)@
NOTE  /4.7,6.15,@(.6,.6,.6,0),(0,0,0,0)@
NOTE  /1.5,6.15,@(.3,.1,.3,0),(0,0,0,0)@
NOTE  /1.5,4.35,@(.3,.3,.3,0),(0.3,-.3,0,0)@
NOTE  /4.5,4.35,@(.3,.3,.3,0),(0,-.6,0,0)@
NOTE  /3.15,2.55,@(.2,.2,.2,0),(0,0,0,0)
FINI  /

```

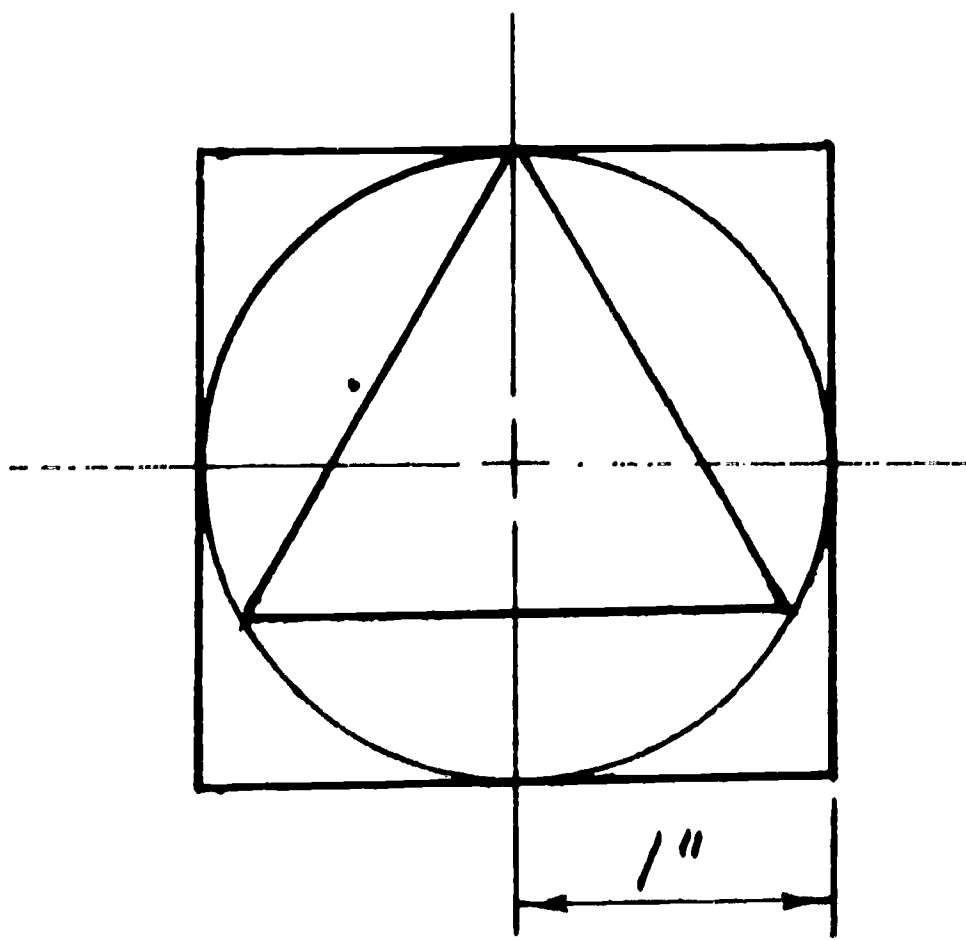

SKETCH 4
1967 SUMMER INSTITUTE

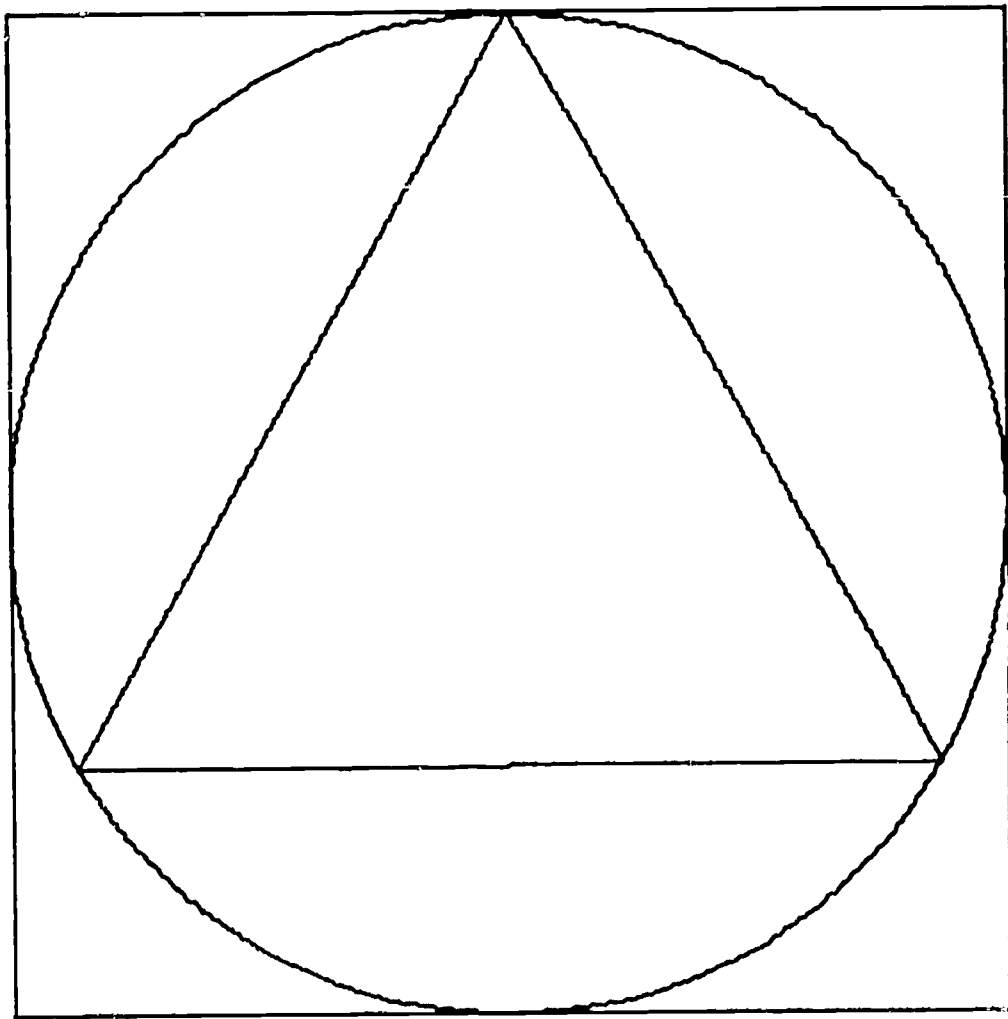
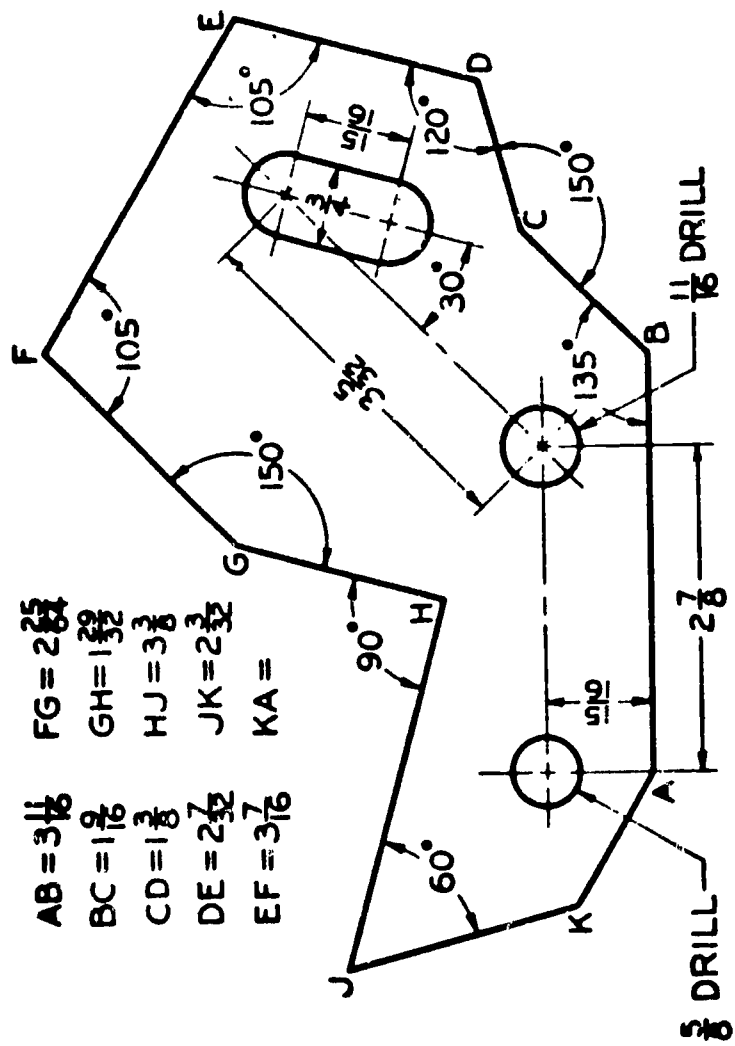

PLATE 4

PICTURE AND FRAME

*** 1967 SUMMER INSTITUTE

```
$$ PLATE 4          SQUARE INSCRIBED IN A CIRCLE
BGX      =THICK ,VIEW /
          LN      /1.5,.5,DX,6.5
          LN      /DY,10
          LN      /DX,-6.5
          LN      /DY,-10
          LN      /1.5,1.25,DX,6.5
          END     /BOX
          DRAW    /BOX
          ALPHAP/(.3,.3,.3,0),(0,0,0,0)
          TITLE/2.05,.875,@ PICTURE AND FRAME@
          ALPHAP/(.2,.2,.2,0),(0,0,0,0)
          TITLE /6,1.5,@PLATE 4@
PICT     = VIEW /
          ORIGIN/4.75,6
          SCALE /2
          LN      /-1,-1,DX,2
          LN      /DY,2
          LN      /DX,-2
          LN      /DY,-2
          CIRCLE/0,0,1
P1       = PT      /0,0,ATANGL,90,LENGTH,1
P2       = PT      /0,0,ATANGL,210,LENGTH,1
P3       = PT      /0,0,ATANGL,330,LENGTH,1
          LN      /P1,P2
          LN      /P2,P3
          LN      /P3,P1
          END     /PICT
          DRAW    /PICT
          FINI    /
```



SKETCH 5
1967 SUMMER INSTITUTE

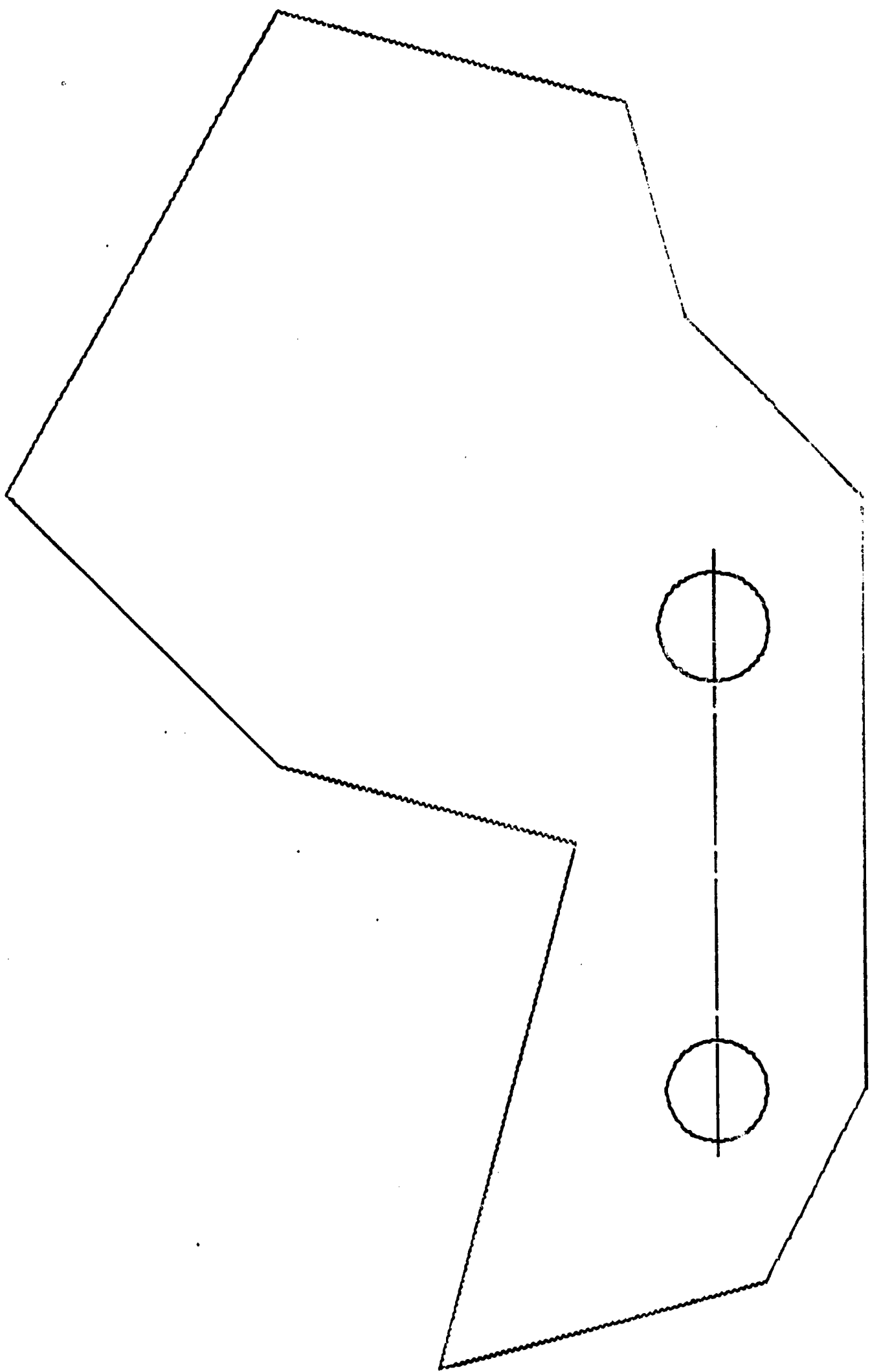

PLATE 5

SHEAR PLATE

*** 1967 SUMMER INSTITUTE

\$\$ PLATE 5
BOX =THICK,

LINES AT ANGLES TO PART AXIS-SHEAR PLATE LONG X
VIEW/

LN /.5,.5,DX,10
LN /DY,6.5
LN /DX,-10
LN /DY,-6.5
LN /1.25,.5,DY,6.5

END/BOX

DRAW/BOX

ALPHAP/(.5,.5,0,-.5),(0,0,0,270)

TITLE /.875,6.8,@ SHEAR PLATE@

ALPHAP/(.2,.2,0,-.2),(0,0,0,270)

TITLE /1.5,2.5,@PLATE 5@

PLATE =
A =

VIEW /

POINT /3.45,1.08

LINE /A,DX,3+11/16

LINE /PPP,ATANGL,45,LENGTH,1+9/16

LINE /PPP,ATANGL,15,LENGTH,1+3/8

LINE /PPP,ATANGL,75,LENGTH,2+7/32

LINE /PPP,ATANGL,150,LENGTH,3+7/16

LINE /PPP,ATANGL,225,LENGTH,2+25/64

LINE /PPP,ATANGL,255,LENGTH,1+29/32

LINE /PPP,ATANGL,165,LENGTH,3+3/8

P1 =

LINE /PPP,ATANGL,285,LENGTH,2+3/32

LINE /PPP,A

KA =

DIST((POINT/P1),A)

P2 =

PT /A,DY,15/16

CR /P2,5/16

P3 =

PT /P2,DX,2+7/8

CR /P3,11/32

PT /DX,.125

CTRLN, LN /DX,-3.75

END /PLATE

DRAW /PLATE

FINI/

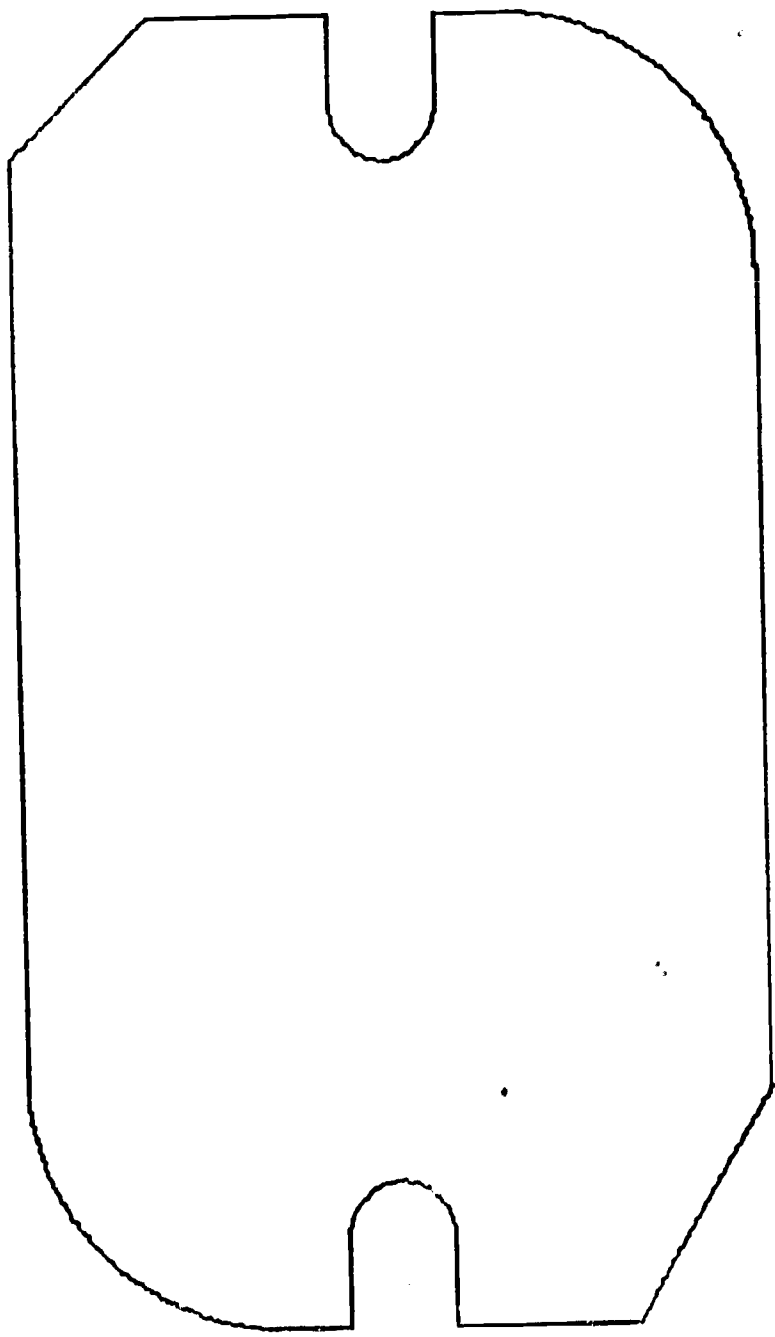

PLATE 6

FIXTURE BASE

*** 1967 SUMMER INSTITUTE

\$\$ PLATE 6 COMBINING ARCS AND LINES-FIXTURE BASE

```
BOX =THICK ,VIEW /
LN /1.5,.5,DX,6.5
LN /DY,10
LN /DX,-6.5
LN /DY,-10
LN /1.5,1.25,DX,6.5
END /BOX
DRAW /BOX
ALPHAP/(.2,.2,.2,0),(0,0,0,0)
TITLE/5.5,1.5,@PLATE 6@
ALPHAP/(.4,.3,.4,0),(0,0,0,0)
TITLE /2.15,.875,@ FIXTURE BASE@

BASE =
VIEW /
SCALE /3/4
ORIGIN/4.75,6
LINE /2,-2.25,ATANGL,240,TILLY,-3.5
LINE /PPP,ATANGL,180,TILLX,9/32
LINE /DY,.5
ARC /0,-3,9/32,0,180
LINE /PPP,DY,-.5
LINE /DX,-(2-9/32)
ARC /1.375
LINE /DY,6.25
LINE /DX,3/4,DY,3/4
LINE /DX,2-(3/4+9/32)
LINE /DY,-.5
ARC /0,3,9/32,180,180
LINE /DY,.5
LINE /DX,2-9/32
ARC /1.375
LINE /DY,-5.75
END /BASE
DRAW /BASE
FINI/
```

1967 SUMMER INSTITUTE
MIAMI-DADE JUNIOR COLLEGE

1967 SUMMER • INSTITUTE
MIAMI-DADE JUNIOR COLLEGE

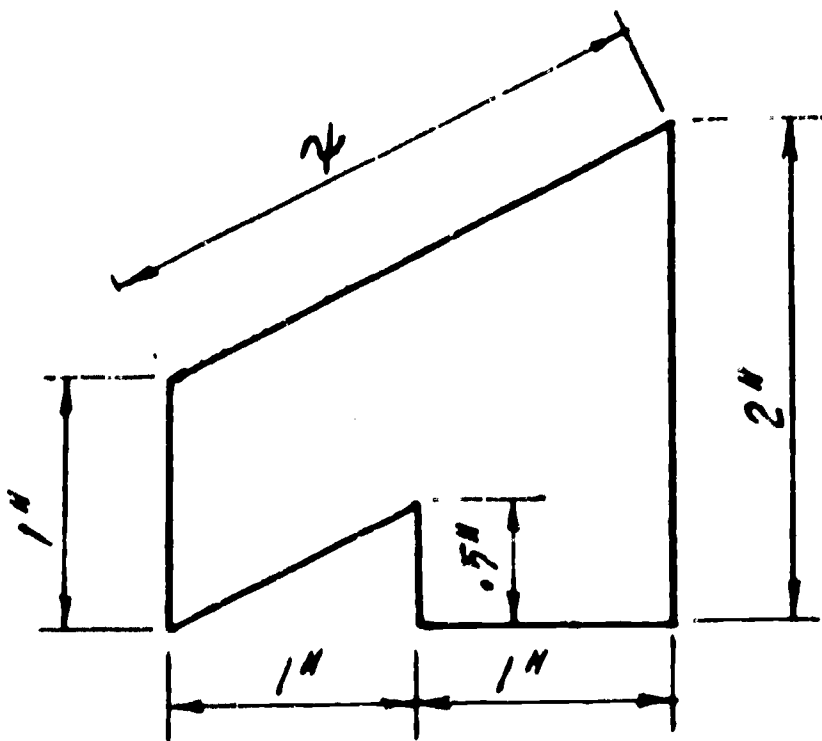

SKETCH 8
1967 SUMMER INSTITUTE

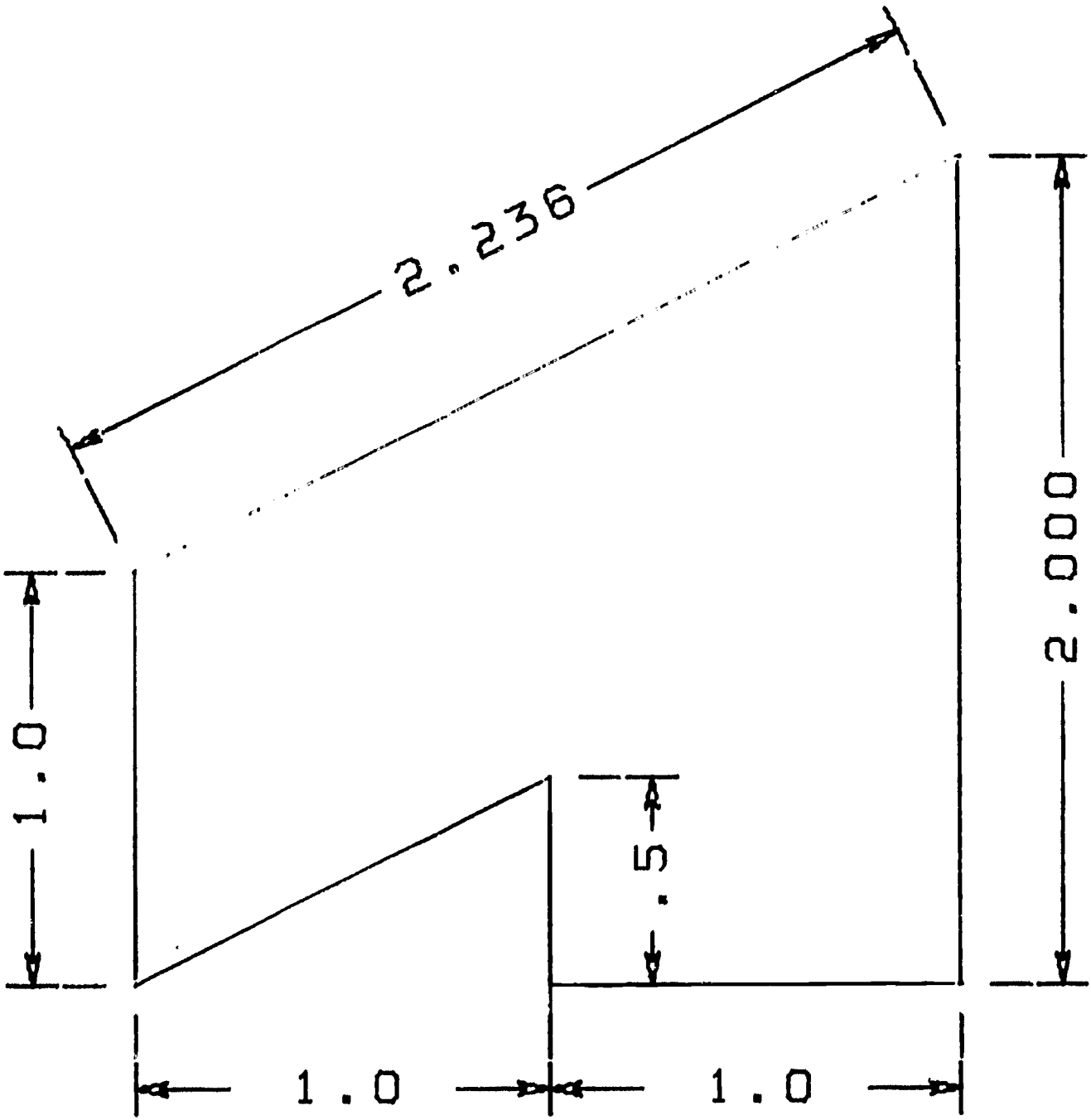

PLATE 8

1967 SUMMER INSTITUTE
MIAMI-DADE JUNIOR COLLEGE

*** 1967 SUMMER INSTITUTE

```

$$ PLATE 8          DIMENSIONING A PART
  BOX      =        VIEW /
                  CALL /FRAME1,,X=6.5,,Y=10,,ORX=1.5,,ORY=.5
                  END /BOX
                  DRAW /BOX
  ABC      =        VIEW /
                  SCALE /2
                  ORIGIN/2.5,4
  L1       =        LINE /DY,1
  L2       =        LINE /DX,2,DY,1
  L3       =        LINE /DY,-2
  L4       =        LINE /DX,-1
  L5       =        LINE /DY,.5
  L6       =        LINE /DX,-1,DY,-.5
                  END /ABC
                  DRAW /ABC
                  DIMST /XSMALL,YCOMP,L1,.5
                  MASK /DP,D10
                  DIM /L1
                  DIMST /YLARGE,TRUE,L2,.5
                  MASK /DP,D30
                  DIMP /.5,.2,1,1
                  DIM /L2
                  DIMST /XLARGE,YCOMP,L3,.5
                  DIM /L3
                  DIMST /YSMALL,XCOMP,L4,.5
                  MASK /DH,D10
                  DIM /L4
                  INDEX /-1
                  DIM /L6
                  DIMST /XLARGE,YCOMP,L5,.5
                  MASK /DP,D10
                  DIM /L5
                  ALPHAP/(.2,.2,.2,0),(0,0,0,0)
                  FINI /

```

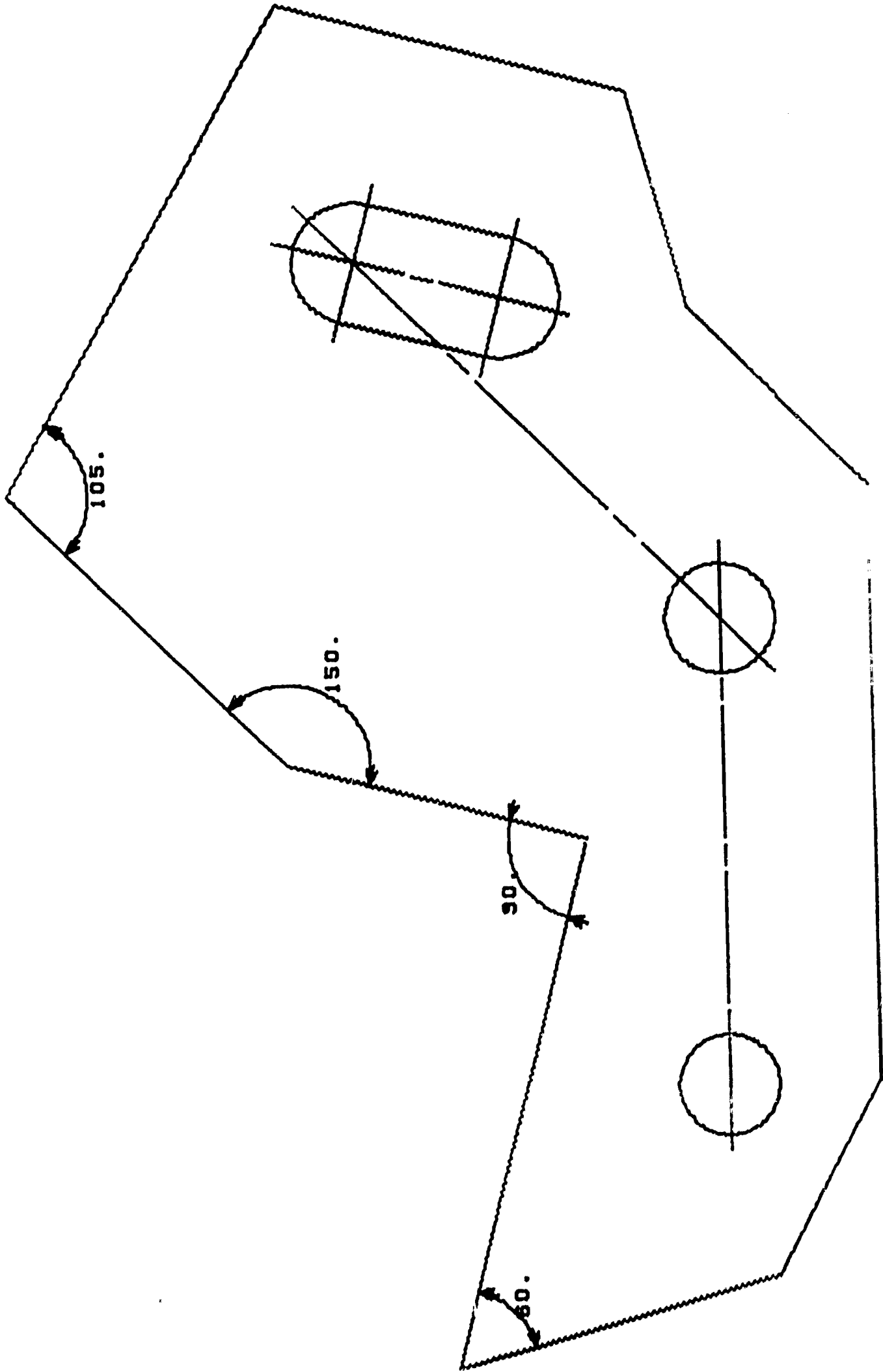

PLATE 9

1967 SUMMER INSTITUTE
MIAMI-DADE JUNIOR COLLEGE

*** 1967 SUMMER INSTITUTE

```

SS PLATE 9      SHEAR PLATE WITH DIMENSIONS    LONG X
BOX            =      VIEW /
                CALL /FRAME1,,X=10,,Y=6.5,,ORX=.5,,ORY=.5
                END/BOX
                DRAW/BOX
                ALPHAP/(.2,.2,0,-.2),(0,0,0,270)
                TITLE /1.5,2.5,2PLATE 9@

PLATE         =      VIEW /
A             =      ORIGIN/NOMORE
                POINT /3.45,1.08
                LINE  /A,DX,3+11/16
                LINE  /PPP,ATANGL,45,LENGTH,1+9/16
                LINE  /PPP,ATANGL,15,LENGTH,1+3/8

D             =      POINT /PPP
                LINE  /PPP,ATANGL,75,LENGTH,2+7/32

E             =      POINT /PPP
                LINE  /PPP,ATANGL,150,LENGTH,3+7/16

F             =      POINT /PPP
                LINE  /PPP,ATANGL,225,LENGTH,2+25/64

G             =      POINT /PPP
                LINE  /PPP,ATANGL,255,LENGTH,1+29/32

H             =      POINT /PPP
                LINE  /PPP,ATANGL,165,LENGTH,3+3/8

J             =      POINT /PPP
P1            =      LINE  /PPP,ATANGL,285,LENGTH,2+3/32
                LINE  /PPP,A

P2            =      PT    /A,DY,15/16
                CR    /P2,5/16

P3            =      PT    /P2,DX,2+7/8
                CR    /P3,11/32
                PT    /DX,.125
                CTRLN, LN /DX,-3.75

P4            =      PT    /P3,ATANGL,225,LENGTH,15/32
LCL           =CTRLN , LN /P4,ATANGL,45,LENGTH,3+20/32
                CTRLN , LN /(PT/LCL),ATANGL,45,LENGTH,1/2

P5            =      PT    /(PT/LCL),ATANGL,75,LENGTH,1/2
P6            =      PT    /(PT/LCL),ATANGL,255,LENGTH,15/16
P7            =      PT    /P6,ATANGL,255,LENGTH,1/2
P8            =      PT    /(PT/LCL),ATANGL,165,LENGTH,1/2
LXL           =CTRLN , LN /P5,P7
L12           =CTRLN , LN /P8,PERPTD,LXL
                CTRLN , LN /PPP,ATANGL,345,LENGTH,1/2

P9            =      PT    /(PT/LCL),ATANGL,165,LENGTH,3/8
P10           =      PT    /P6,ATANGL,165,LENGTH,3/8
                LN    /P10,P9
                ARC    /(PT/LCL),3/8,165,180,CLW
                LN    /PPP,ATANGL,255,LENGTH,15/16
                ARC    /P6,3/8,345,180 ,CLW
                CTRLN , LN /P6,ATANGL,165,LENGTH,1/2
                CTRLN , LN /P6,ATANGL,345,LENGTH,1/2
                END    /PLATE
                DRAW   /PLATE

```

DIMP /0.5,0.1,1.1
DIM /J,0.5,285,60
DIM /M,0.5,165,-90
DIM /G,0.5,255,150
DIM /F,0.5,225,105
FINI/

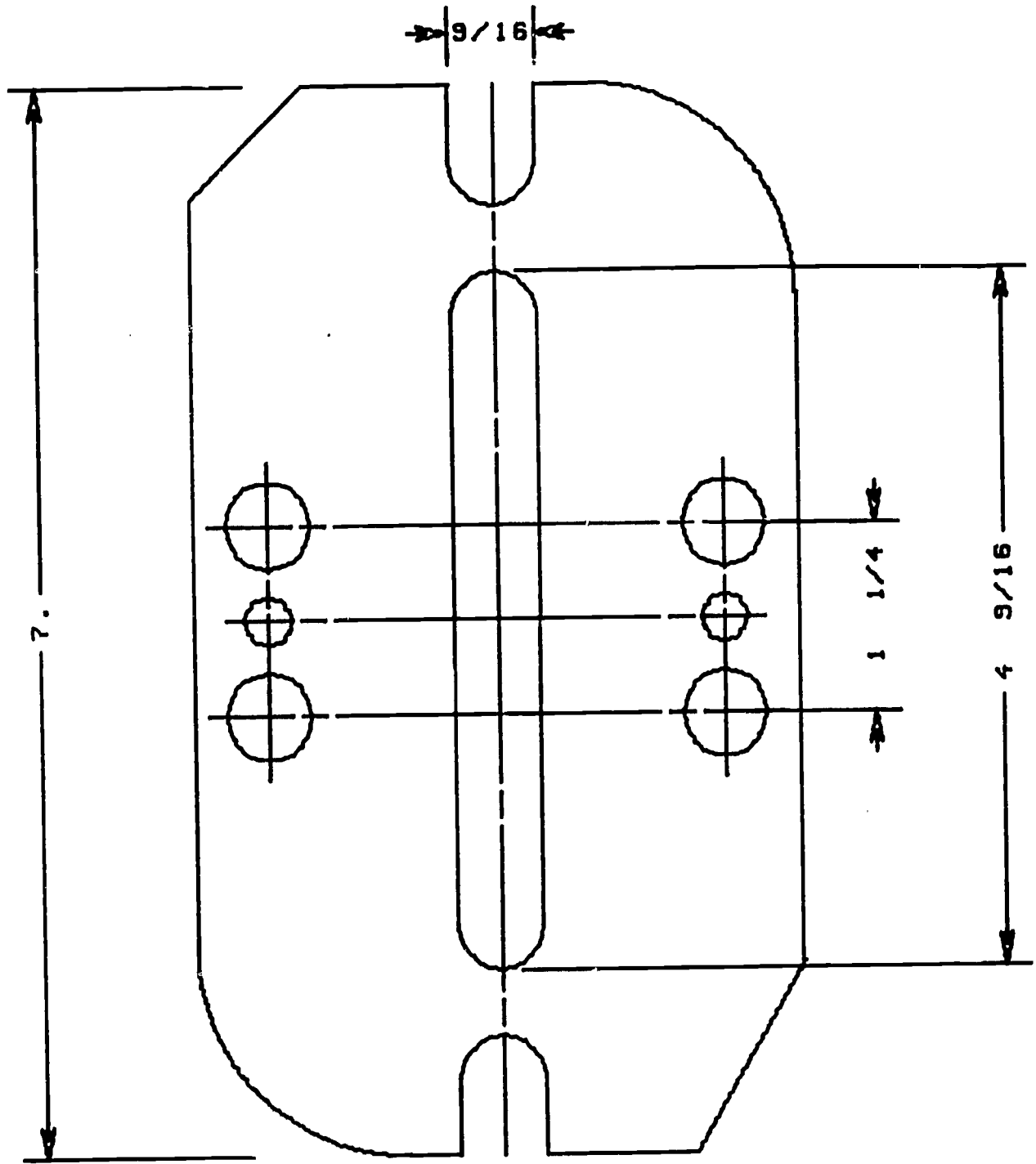

PLATE 10

1967 SUMMER INSTITUTE
MIAMI-DADE JUNIOR COLLEGE

***** 1967 SUMMER INSTITUTE

```

$$ PLATE 10          FIXTURE BASE WITH DIMENSIONS
BOX =              VIEW/
                  CALL /FRAME1,,X=6.5,,Y=10,,ORX=1.5,,ORY=.5
                  END  /BOX
                  DRAW  /BOX
                  ALPHAP/(.2,.2,.2,0),(0,0,0,0)
                  TITLE/5.5,1.5,@PLATE 10@
BASE =            VIEW /
                  SCALE /3/4
                  ORIGIN/4.75,6
                  LINE  /2,-2.25,ATANGL,240,TILLY,-3.5
                  LINE  /PPP,ATANGL,180,TILLX,9/32
                  LINE  /DY,.5
                  ARC   /0,-3,9/32,0,180
                  LINE  /PPP,DY,-.5
                  LINE  /DX,-(2-9/32)
                  ARC   /1.375
                  LINE  /DY,6.25
                  LINE  /DX,3/4,DY,3/4
                  LINE  /DX,2-(3/4+9/32)
P1 =              PT   /PPP
                  LINE  /DY,-.5
                  ARC   /0,3,9/32,180,180
                  LINE  /DY,.5
P2 =              PT   /PPP
                  LINE  /DX,2-9/32
                  ARC   /1.375
                  LINE  /DY,-5.75
P3 =              PT   /-1.5,-3.5
P4 =              PT   /-1.5,3.5
                  END  /BASE
                  DRAW  /BASE
                  MASK  /@P,F16@
                  DIMP  /.25,.1,2,2
                  DIMST /YLARGE,XCOMP,P1,P2,.25
                  DIM   /P1,P2
                  DIMP  /.5,.1,1,1
                  DIMST /XSMALL,YCOMP,-2,-1,-2,1,.75
                  DIM   /P3,P4
SLOT =           VIEW /
P5 =             PT   /0,-(2+9/32)
P6 =             PT   /0,2+9/32
                  LN   /9/32,0,DY,2
                  ARC  /0,2,9/32,0,180
                  LN   /DY,-2
                  CTRLN,LN /0,0,DY,3.5
                  END  /SLOT
                  DRAW  /SLOT
                  DRAW  /MIRY(SLOT)
                  DIMST /XLARGE,YCOMP,P5,P6,2.5
                  DIM   /P5,P6
CIR =           VIEW /

```

```

P7      =      PT      /1.5,-5/8
P8      =      PT      /1.5,5/8
          CTRLN, LN    /0,-5/8,DX,1+29/32
          CTRLN, LN    /0,0,DX,1+25/32
          CTRLN, LN    /0,5/8,DX,1+29/32
          CTRLN, LN    /1.5,-(1+1/32),DY,2+1/16
          CR           /1.5,-5/8,9/32
          CR           /1.5,0,5/32
          CR           /1.5,5/8,9/32
          END         /CIR
          DRAW        /CIR
          DRAW        /MIRX(CIR)
          DIMST       /XLARGE,YCOMP,P7,P8,.75
          DIMP        /.6,.1,2,2
          DIM         /P7,P8

```

```

FINI /

```

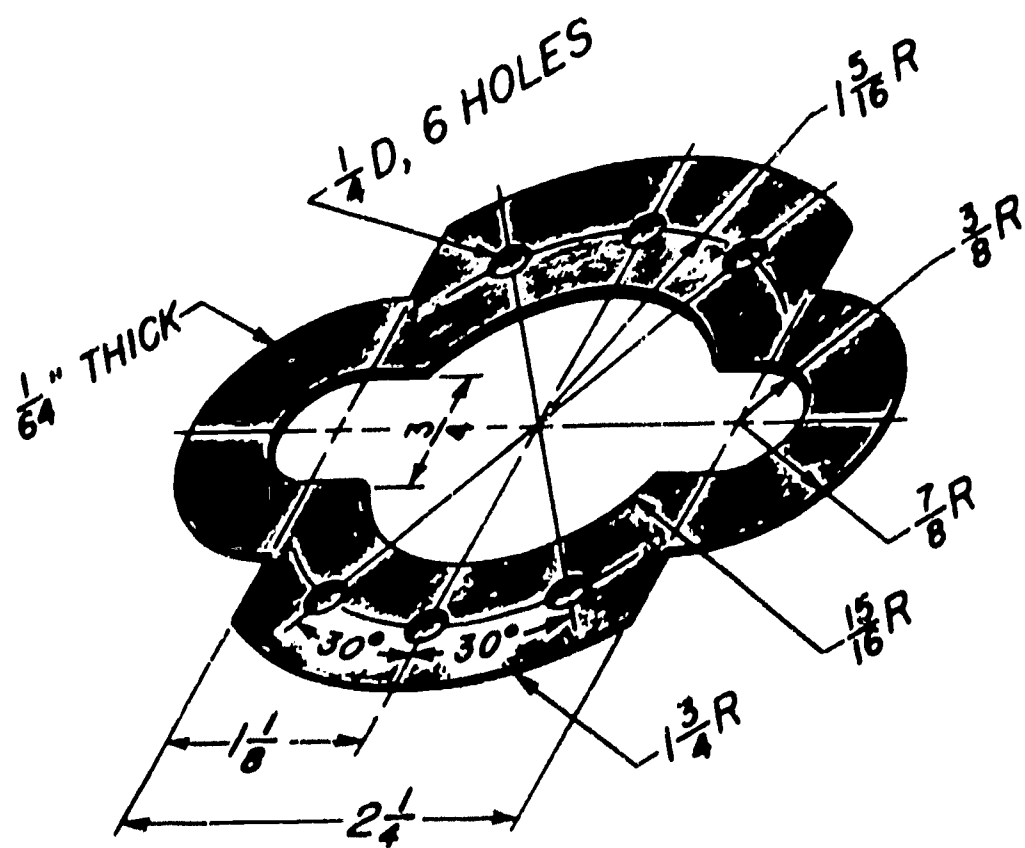

SKETCH II

1967 SUMMER INSTITUTE

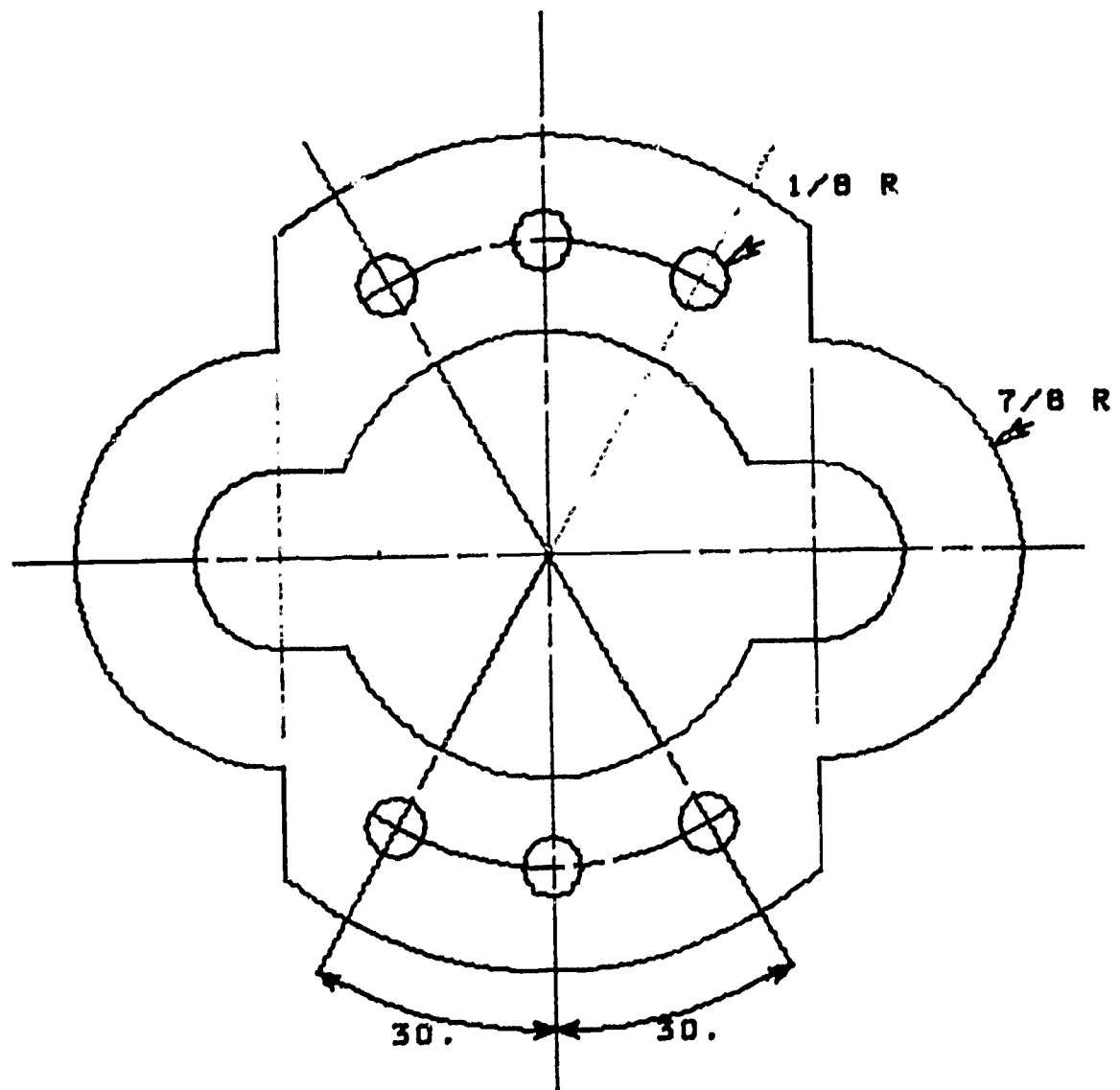

PLATE 11

1967 SUMMER INSTITUTE
MIAMI-DADE JUNIOR COLLEGE

***** 1967 SUMMER INSTITUTE

\$\$ PLATE 11

INTERSECTION OF ARCS-GASKET
 ALPHAP/(.2,.2,.2,0),(0,0,0,0)
 TITLE /6,1.5,@PLATE 11@

```

GASKET= VIEW/
L1 =CONSTR,LINE /1.125,-3,DY,.01
L2 =CONSTR,LINE /-1.125,-3,DY,.01
L3 =CONSTR,LINE /-2,-3/8,DX,.01
L4 =CONSTR,LINE /-2,3/8,DX,.01
C1 =CONSTR,CIRCLE/0,0,1.75
P1 = POINT /YLARGE,INTOF,L2,C1
P2 = POINT /YLARGE,INTOF,L1,C1
P3 = POINT /YSMALL,INTOF,L1,C1
P4 = POINT /YSMALL,INTOF,L2,C1
C2 =CONSTR,CIRCLE/1.125,0,7/8
C3 =CONSTR,CIRCLE/-1.125,0,7/8
P5 = POINT /YLARGE,INTOF,L1,C2
P6 = POINT /YSMALL,INTOF,L1,C2
P8 = POINT /YLARGE,INTOF,L2,C3
P7 = POINT /YSMALL,INTOF,L2,C3
ARC /P1,P2,YSMALL,RADIUS,1.75,CLW
LINE /PPP,P5
ARC /P5,P6,XSMALL,RADIUS,7/8,CLW
LINE /PPP,P3
ARC /P3,P4,YLARGE,RADIUS,1.75,CLW
LINE /PPP,P7
ARC /P7,P8,XLARGE,RADIUS,7/8,CLW
LINE /PPP,P1
C4 =CONSTR,CIRCLE/0,0,15/16
C5 =CONSTR,CIRCLE/-1.125,0,3/8
C6 =CONSTR,CIRCLE/1.125,0,3/8
P20 = POINT /YLARGE,INTOF,L1,C6
P21 = POINT /YSMALL,INTOF,L1,C6
P22 = POINT /YSMALL,INTOF,L2,C5
P23 = POINT /YLARGE,INTOF,L2,C5
P24 = POINT /XSMALL,INTOF,L4,C4
P25 = POINT /XLARGE,INTOF,L4,C4
P26 = POINT /XLARGE,INTOF,L3,C4
P27 = POINT /XSMALL,INTOF,L3,C4
ARC /P24,P25,YSMALL,RADIUS,15/16,CLW
LINE /PPP,P20
ARC /P20,P21,XSMALL,RADIUS,3/8,CLW
LINE /PPP,P26
ARC /P26,P27,YLARGE,RADIUS,15/16,CLW
LINE /P27,P22
ARC /P22,P23,XLARGE,RADIUS,3/8,CLW
LINE /P23,P24
CLACIR=CTRLN ,SHAPE /
LN /-2.25,0,2.25,0
LN /0,-2.25,0,2.25
LN /-1.125,-.75,-1.125,.75
LN /1.125,-.75,1.125,.75
LN /0,0,ATANGL,60,LENGTH,2
  
```

```

LN      /0,0,ATANGL,120,LENGTH,2
LN      /0,0,ATANGL,240,LENGTH,2
LN      /0,0,ATANGL,300,LENGTH,2
ARC     /0,0,1+5/16,55,70
ARC     /0,0,1+5/16,235,70
END     /CLACIR
C7      L101 =CONSTR,LN      /0,0,ATANGL,60,LENGTH,1+5/16
      =      CIRCLE/(PT/L101),1/8
L111   =CONSTR,LN      /0,0,ATANGL,120,LENGTH,1+5/16
      CIRCLE/(PT/L111),1/8
L112   =CONSTR,LN      /0,0,ATANGL,240,LENGTH,1+5/16
      CIRCLE/(PT/L112),1/8
      CIRCLE/0,1+5/16,1/8
L113   =CONSTR,LN      /0,0,ATANGL,300,LENGTH,1+5/16
      CIRCLE/(PT/L113),1/8
      CIRCLE/0,-1-5/16,1/8
END     /GASKET
ORIGIN/4.75,6
DRAW   /GASKET
MASK   /@H,F8@
DIMP   /.5,.2,1,1
DIM     /0,0,2,240,30
DIM     /0,0,2,270,30
DIMP   /1.2,.2,0,2
DIMCR  /C7,30,@1/8 R@
DIMP   /3.5,.2,0,2
DIMCR  /C2,30,@7/8 R@
FINI   /

```

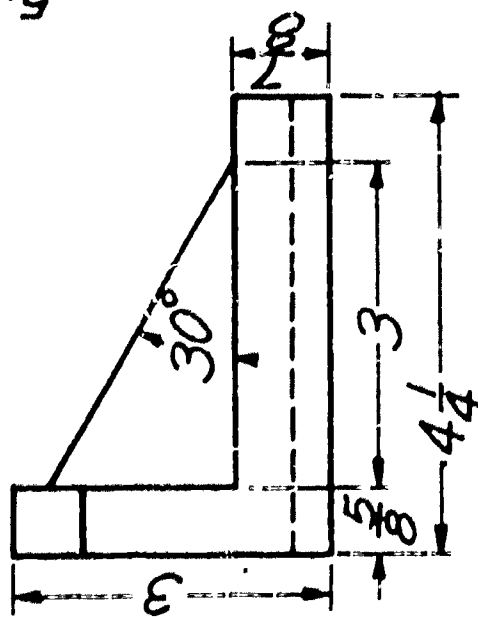
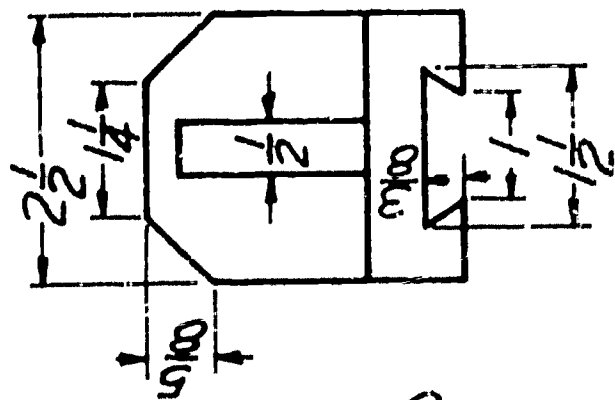

SKETCH 12

1967 SUMMER INSTITUTE

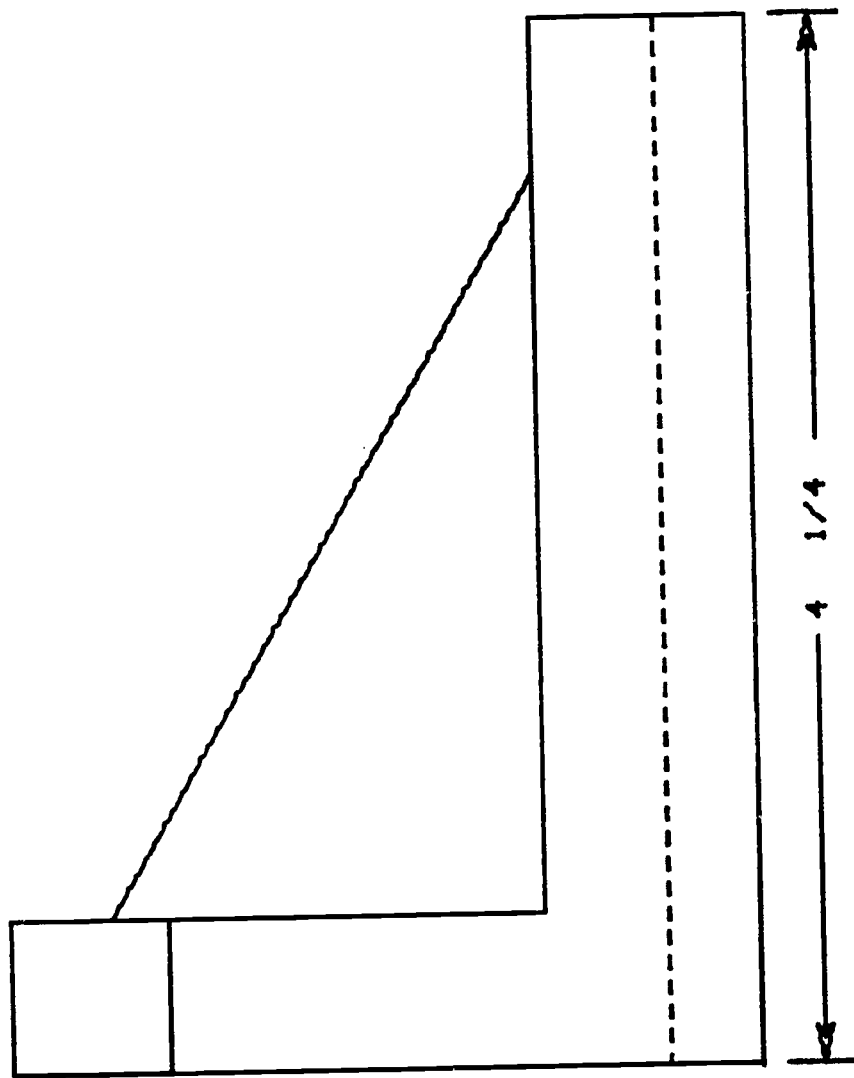
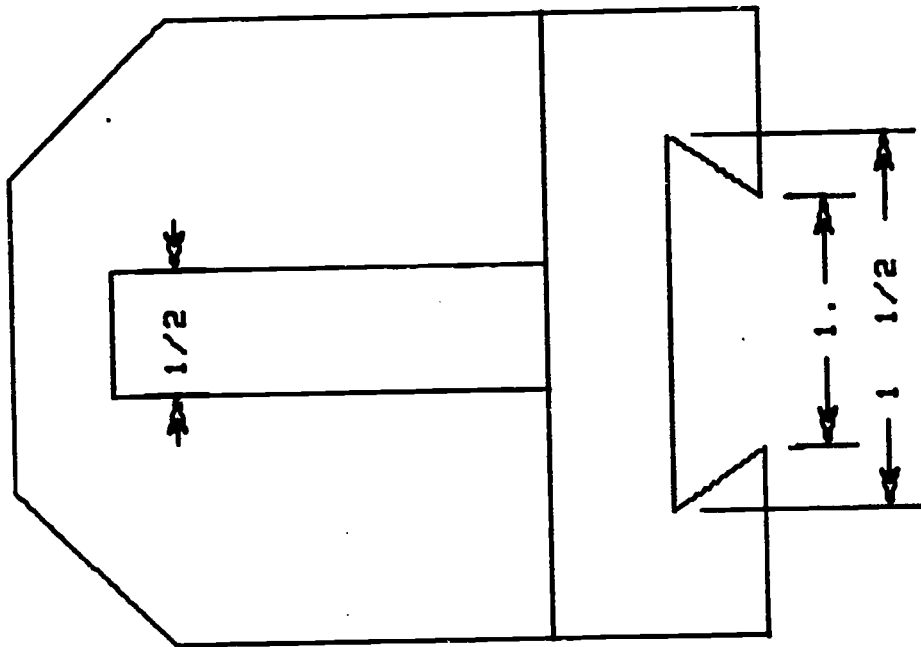

PLATE 12

1967 SUMMER INSTITUTE
 MIAMI-DADE JUNIOR COLLEGE

***** 1967 SUMMER INSTITUTE

```

$$ PLATE 12          TWO VIEW DRAWING WITH UNKNOWN DISTANCE-DOVETAIL STOP
                    (LONG -X-)
                    ALPHAP/(.2,.2,0,-.2),(0,0,0,270)
                    TITLE /1.5,2.5,@PLATE 12@

SIDE      =        VIEW /
P2        =        LN   /DX,4.25
                    PT   /PPP
                    LN   /DY,7/8
                    LN   /DX,-(4.25-5/8)
                    LN   /DY,2.125
                    LN   /DX,-5/8
P1        =        LN   /DY,-3
                    PT   /PPP
                    LN   /0,2.375,DX,5/8
                    LN   /3.625,7/8,ATANGL,150,TILLX,5/8
                    DOTTED,LN /0,3/8,DX,4.25
                    END   /SIDE
                    ORIGIN/2.25,2.25
                    DRAW  /SIDE
                    MASK  /@P,F16@
                    DIMP  /.5,.1,1,1
                    DIMST /YSMALL,XCOMP,P1,P2,.25
                    DIM   /P1,P2

FRONT     =        VIEW /
P3        =        LN   /DX,3/4
                    PT   /PPP
                    LN   /DX,-.25,DY,3/8
P4        =        PT   /PPP
                    LN   /DX,1.5
P5        =        PT   /PPP
                    LN   /DX,-.25,DY,-3/8
P6        =        PT   /PPP
                    LN   /DX,3/4
                    LN   /DY,2.375
                    LN   /DX,-5/8,DY,5/8
                    LN   /DX,-1.25
                    LN   /DX,-5/8,DY,-5/8
                    LN   /DY,-2.375
                    LN   /1,.875,DY,3/COSD(30)*SIND(30)
P7        =        PT   /PPP
                    LN   /DX,.5
P8        =        PT   /PPP
                    LN   /PPP,ATANGL,270,TILLY,7/8
                    CONSTR,LN /DX,1
                    LN   /DX,-2.5
                    END   /FRONT
                    ORIGIN/7,2.25
                    DRAW  /FRONT
                    DIMST /YSMALL,XCOMP,P3,P6,.25
                    DIM   /P3,P6
                    DIM   /P4,P5
                    DIMP  /.3,.1,2,2

```

DIMST /YSMALL,XCOMP,P7,P8,.25
DIMNN /P7,P8
FINI /

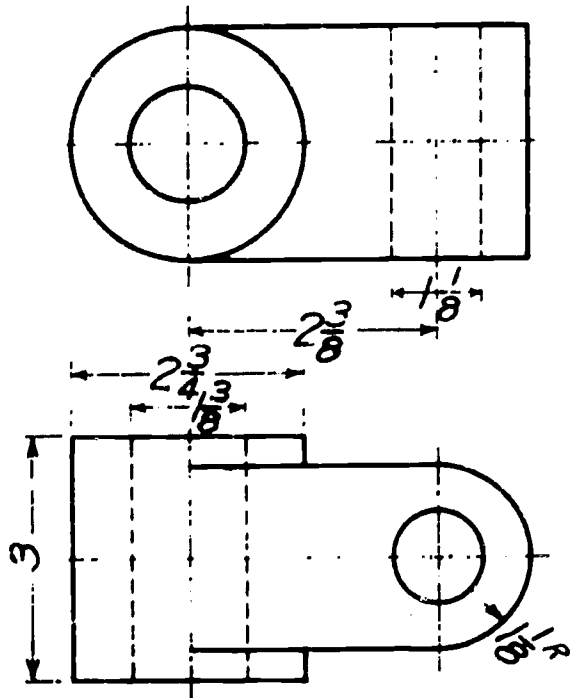

SKETCH 13
1967 SUMMER INSTITUTE

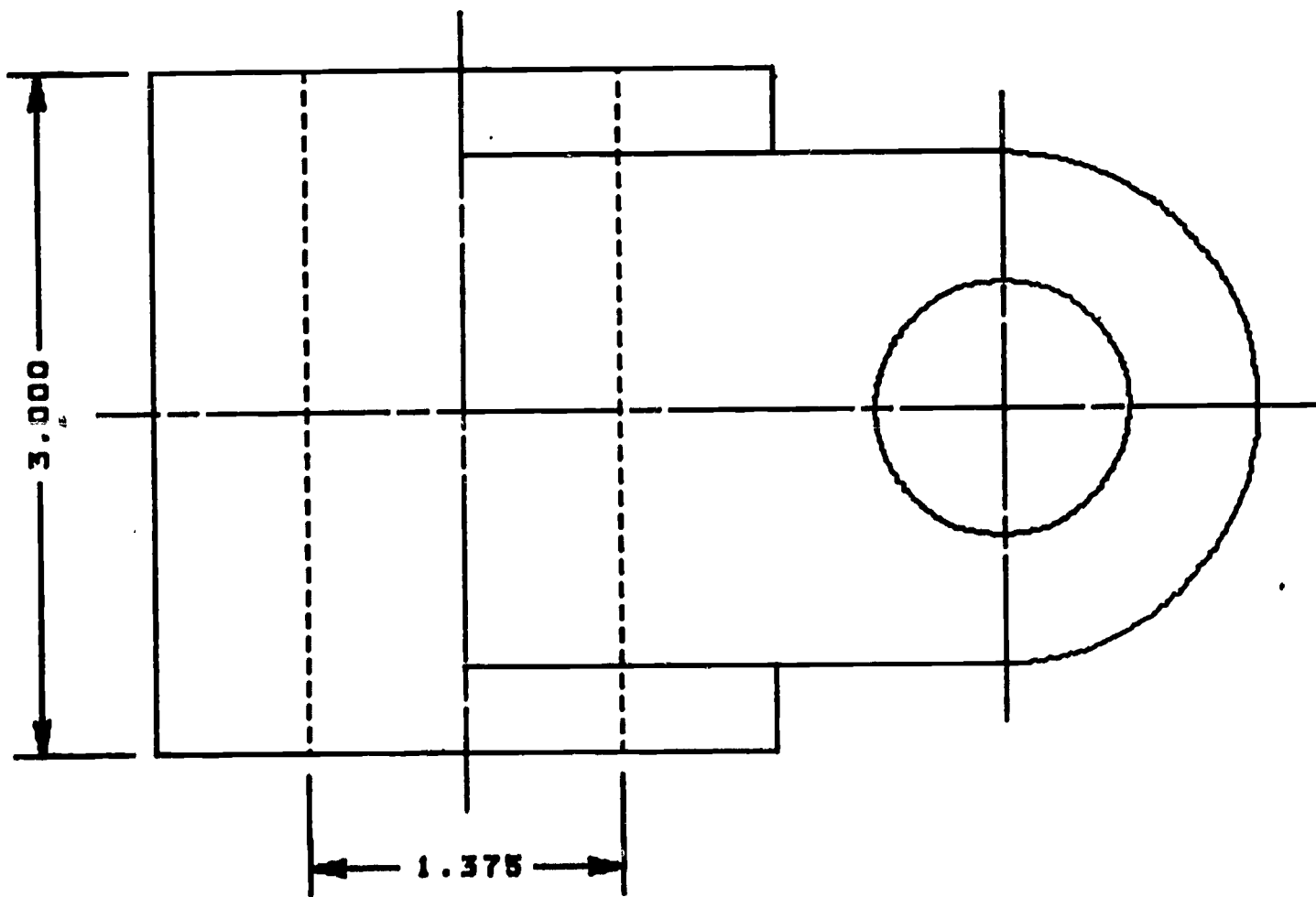
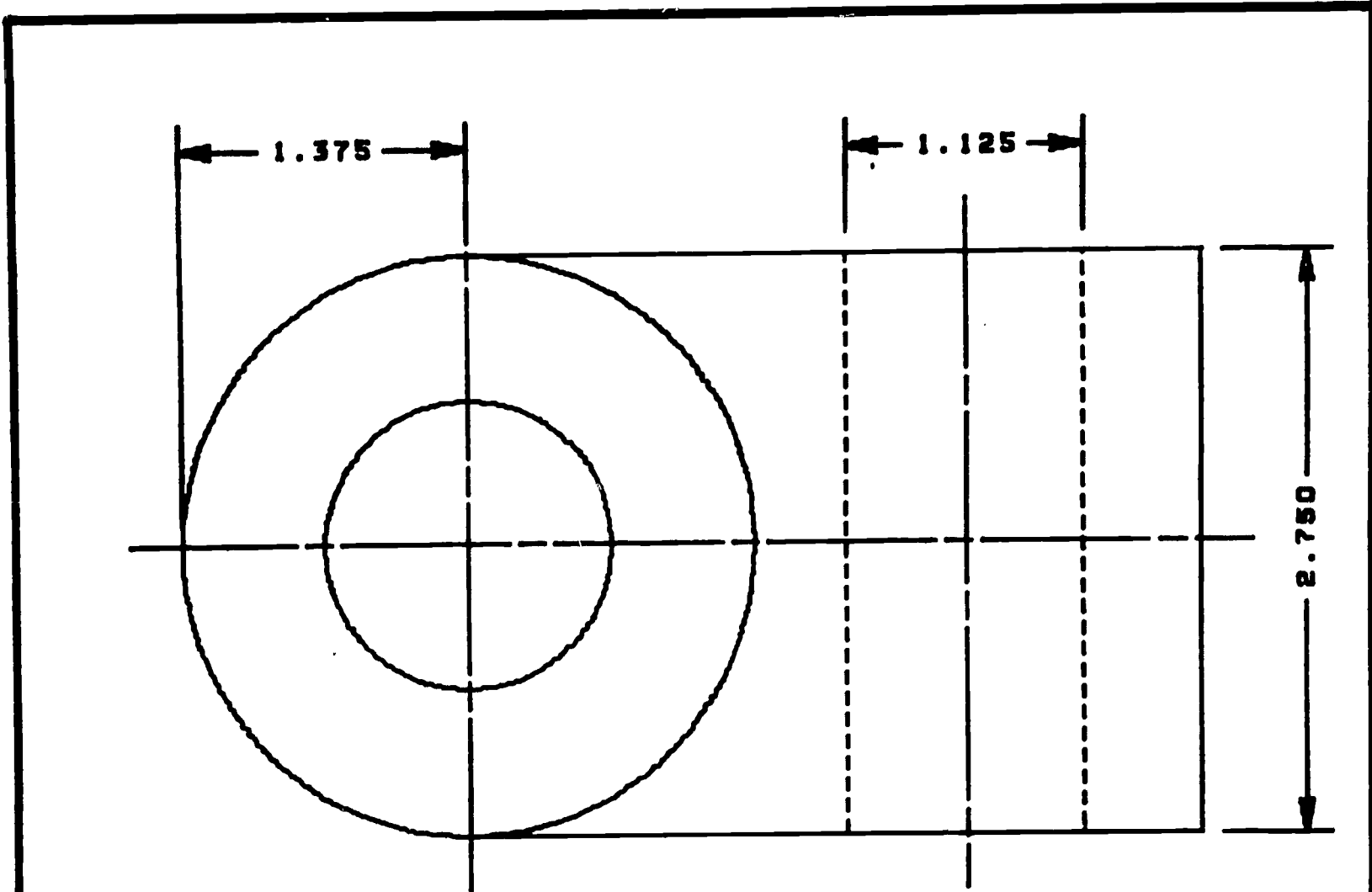

PLATE 13

1967 SUMMER INSTITUTE
MIAMI-DADE JUNIOR COLLEGE

***** 1967 SUMMER INSTITUTE

\$\$ PLATE 13

TWO VIEW DRAWING-CROSS LINK
 ALPHAP/(.2,.2,.2,0),(0,0,0,0)
 TITLE /6,1.5,@PLATE 13@

```

TOP      =      VIEW /
L1      =CTRLN ,LN    /-1.625,0,DX,1.625+2.375+1.125+.25
          CTRLN ,LN    /2.375,1.625,DY,-1.625*2
          CTRLN ,LN    /0,-1.625,DY,1.625*2
          CR          /0,0,1.375/2
C1      =      CR          /0,0,2.75/2
          LN          /0,1.375,DX,3.5
P1      =      PT          /PPP
          LN          /DY,-2.75
P2      =      PT          /PPP
          LN          /PPP,LEFT,TANTO,C1
          DOTTED,LN    /2.375-1.125/2,1.375,DY,-2.75
          CONSTR,LN   /DX,1.125
          DOTTED,LN   /DY,2.75
P4      =      PT          /PPP
P3      =      PT          /2.375-1.125/2,1.375
P5      =      PT          /0,1.375
P6      =      PT          /XSMALL,INTOF,L1,C1
          END          /TOP
          ORIGIN/2.312+11/8,8.0
          DRAW        /TOP
          MASK        /@P,D3@
          DIMP        /.5,.1,1,1
          DIMST       /YLARGE,XCOMP,P3,P4
          DIM         /P3,P4
          INDEX       /-1
          DIM         /P6,P5
          DIMP        /.5,.1,1,1
          DIMST       /XLARGE,YCOMP,P1,P2
          DIM         /P1,P2
BOTTOM  =      VIEW /
          CTRLN ,LN    /0,1.375,DY,-(1.125*2+.5)
          CTRLN ,LN    /1.375,0,DX,-(1.125+2.375+2.75/2+.5)
          CTRLN ,LN    /-2.375,1.75,DY,-3.5
          LN          /-(2.375-2.75/2),1.125,DY,1.5-1.125
          LN          /DX,-2.75
P7      =      PT          /PPP
          LN          /DY,-3
P8      =      PT          /PPP
          LN          /DX,2.75
          LN          /DY,1.5-1.125
          CONSTR,LN   /DX,-(2.75/2)
          LN          /DX,2.375
          ARC         /0,0,1.125,270,180
          LN          /DX,-2.375
          CR          /0,0,1.125/2
          DOTTED,LN   /-(2.375+1.375/2),1.5,DY,-3
P9      =      PT          /PPP
          CONSTR,LN   /DX,1.375
  
```

P10

```
      PT      /PPP
      DOTTED, LN /DY,3
      END      /BOTTOM
      ORIGIN/4.687+11/8,4.125
      DRAW     /BOTTOM
      MASK     /@P,D3@
      DIMP     /.5,.1,1,1
      DIMST    /XSMALL,YCOMP,P8,P7
      DIM      /P8,P7
      DIMST    /YSMALL,XCOMP,P9,P10
      DIM      /P9,P10
      FINI     /
```

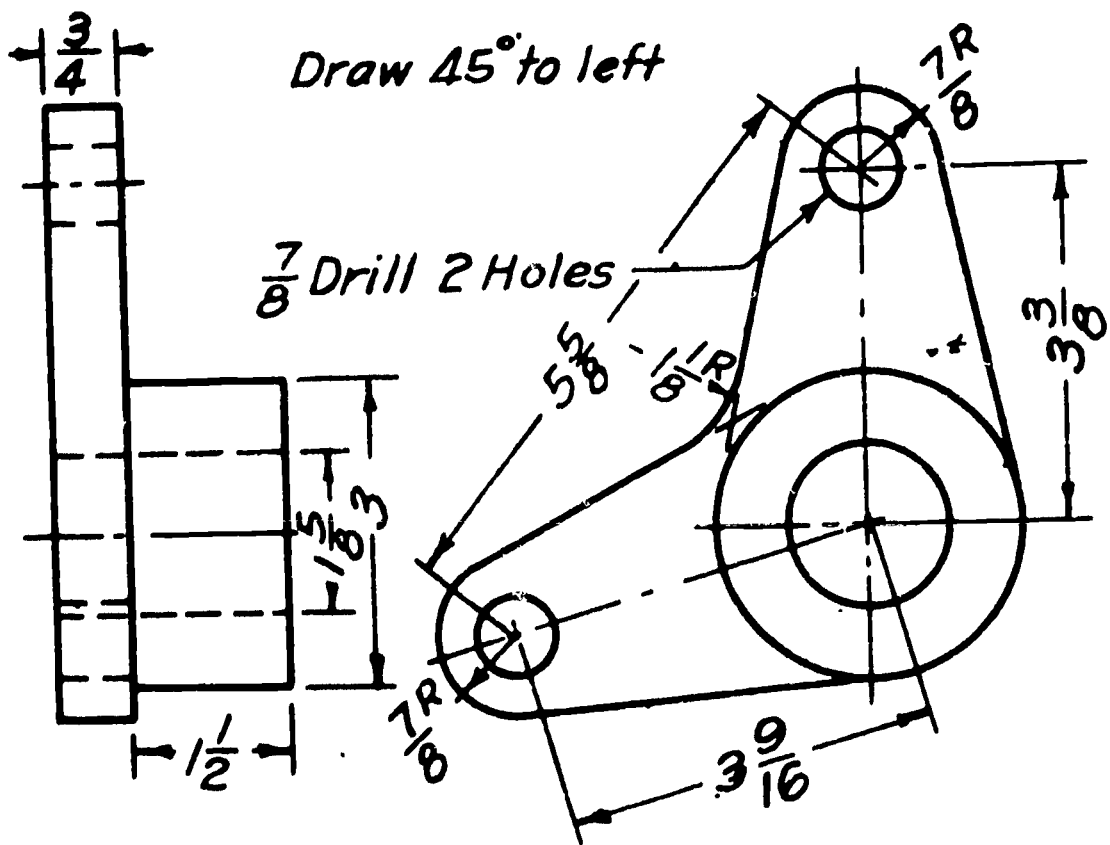

SKETCH 14

1967 SUMMER INSTITUTE

***** 1967 SUMMER INSTITUTE

\$\$ PLATE 14

TWO VIEW DRAWING-BELL CRANK
 ALPHAP/(.2,.2,.2,0),(0,0,0,0)
 TITLE /6,1.5,@PLATE 14@
 SCALE /.5

```

CRANK = VIEW /
      CIRCLE/0,0,1.625/2
C1 = CIRCLE/0,0,1.5
C2 =CONSTR,CR /0,0,3.562
C3 =CONSTR,CR /0,3.375,5.625
    CONSTR,LN /0,0,DY,4.25
L7 =CONSTR,LN /PPP,DX,-.1
    CONSTR,LN /PPP,DY,-(.875-.875/2)
L6 =CONSTR,LN /PPP,DX,-.1
P1 = PT /XSMALL,INTOF,C2,C3
C4 =CONSTR,CR /P1,.875
C5 =CONSTR,CR /0,3.375,.875
L1 =CONSTR,LN /LEFT,TANTO,C1,LEFT,TANTO,C5
L2 =CONSTR,LN /RIGHT,TANTO,C1,RIGHT,TANTO,C4
P2 = PT /INTOF,L1,L2
P3 = LN /RIGHT,TANTO,C1,RIGHT,TANTO,C5
P4 =CONSTR,LN /P2,LEFT,TANTO,C5
    ARC /(PT/P3),(PT/P4),YSMALL,RADIUS,.875
    LN /PPP,P2
    ARC /1.125
P5 = LN /P2,RIGHT,TANTO,C4
P6 =CONSTR,LN /LEFT,TANTO,C1,LEFT,TANTO,C4
    ARC /(PT/P5),(PT/P6),XLARGE,RADIUS,.875
    LN /(PT/P6),RIGHT,TANTO,C1
L3 =CONSTR,LN /0,0,P1
    CTRLN ,LN /ANGOF(L3),LENGTH,4.687
    CTRLN ,LN /-1.75,0,DX,3.5
    CTRLN ,LN /0,-1.75,DY,6.25
    CTRLN ,LN /-1.125,3.375,DX,2.25
    CR /0,3.375,.875/2
P7 =CONSTR,LN /ANGOF(L3),LENGTH,3.562
A1 = ATAND(L3)
    CONSTR,LN /PPP,ATANGL,A1-90,LENGTH,1.125
    CTRLN ,LN /PPP,ATANGL,A1+90,LENGTH,2.25
    CR /(PT/P7),.875/2
L4 =CONSTR,LN /0,0,0,3.375
L5 =CONSTR,LN /P1,(PT/L4)
P8 = PT /INTOF,P6,C4
L8 =CONSTR,LN /P8,DX,-4.25
    LN /PPP,DX,.75
P99 = PT /PPP
L10 =CONSTR,LN /PPP,DY,.1
P9 = PT /INTOF,L7,L10
L9 = LN /P99,P9
    LN /PPP,DX,-.75
P1212 = PT /PPP
L12 =CONSTR,LN /PPP,DY,-.1
P12 = PT /INTOF,L12,L8
  
```

```

P10      =          LN      /P1212,P12
          =          PT      /INTOF,P6,C1
L11      =CONSTR,LN      /PPP,DX,-.1
P11      =          PT      /INTOF,L9,L11
          LN      /P11,DX,1.5
P15      =          PT      /PPP
          LN      /PPP,DY,3
P16      =          PT      /PPP
          LN      /PPP,DX,-1.5
          CONSTR,LN      /PPP,DX,-.75
          CONSTR,LN      /PPP,DY,-.6875
          DOTTED,LN      /PPP,DX,2.25
          CONSTR,LN      /PPP,DY,-1.625
          DOTTED,LN      /PPP,DX,-2.25
          CONSTR,LN      /PPP,DY,1.625/2
          CONSTR,LN      /PPP,DX,-.125
          CTRLN ,LN      /PPP,DX,2.5
          CONSTR,LN      /P1,DY,.875/2
L13      =CONSTR,LN      /PPP,DX,-.1
P13      =          PT      /INTOF,L13,L10
          DOTTED,LN      /P13,DX,-.75
          CONSTR,LN      /PPP,DY,-.875
          DOTTED,LN      /PPP,DX,.75
P14      =          PT      /INTOF,L6,L10
          DOTTED,LN      /P14,DX,-.75
          CONSTR,LN      /PPP,DY,-.875
          DOTTED,LN      /PPP,DX,.75
          CONSTR,LN      /PPP,DY,.875/2
          CONSTR,LN      /PPP,DX,.125
          CTRLN ,LN      /PPP,DX,-1
          END      /CRANK
          ORIGIN/6.25,5.5
          DRAW      /CRANK
          MASK      /@P F32 TN@
          DIMP      /.5,.1,1,1
          DIMST      /XSMALL,YCOMP,P12,P1212,.25
          DIM      /P12,P1212
          DIMST      /XLARGE,YCOMP,P15,P16,.25
          DIM      /P15,P16
          DIMST      /YLARGE,TRUE,L5,.75/2
          DIM      /L5
          DIMST      /YSMALL,TRUE,L3,.75
          DIM      /L3
          DIMP      /2.2,.1,2,2
          DIMST      /YSMALL,XCOMP,P12,P99,.25
          DIM      /P12,P99
          FINI      /

```

ARCS IN THIS SLOT
ARE $\frac{3}{8}$ AND DISTANCES
FROM ARC CENTERS IS 1.5

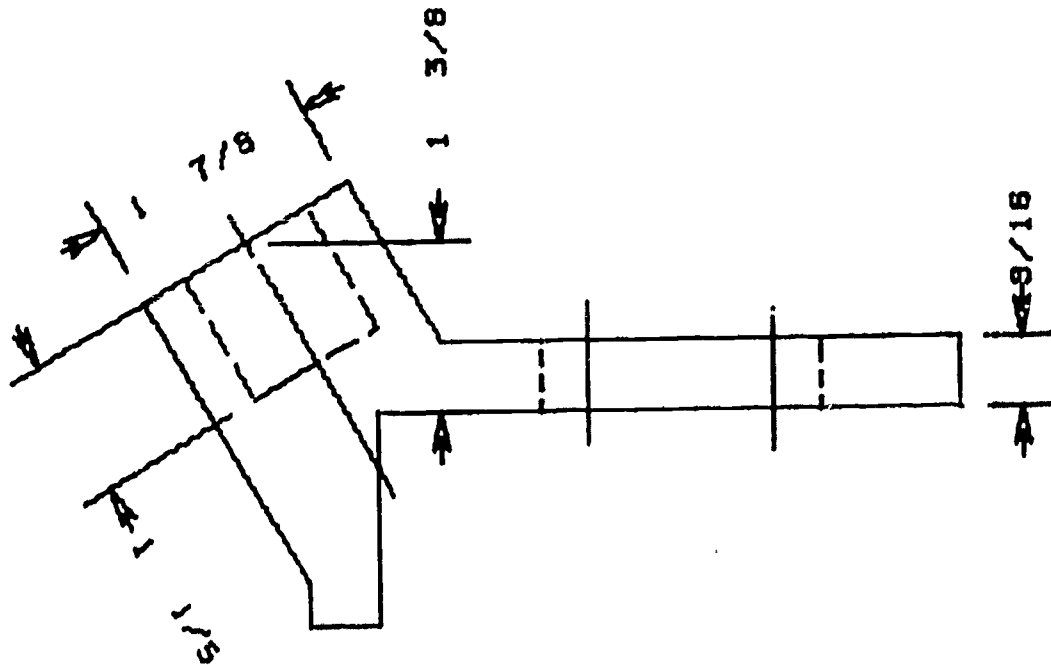
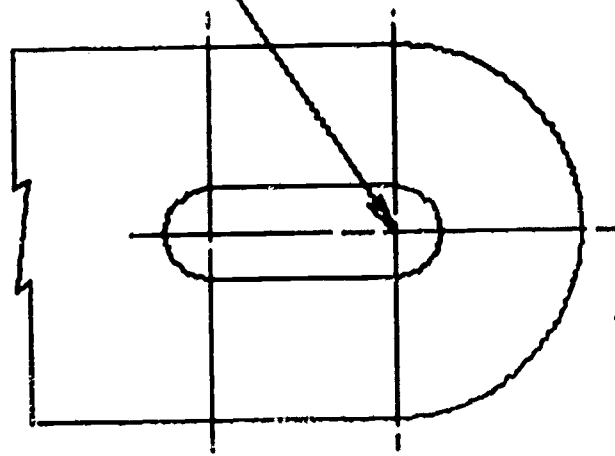
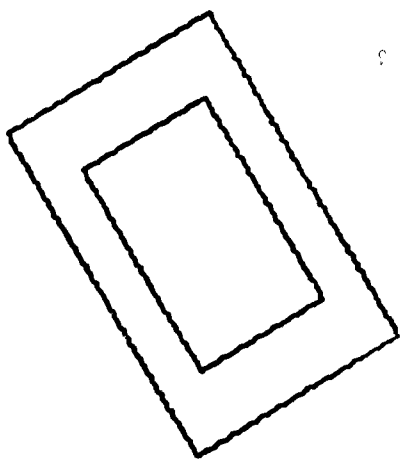

PLATE 15

1967 SUMMER INSTITUTE
MIAMI-DADE JUNIOR COLLEGE

***** 1967 SUMMER INSTITUTE

```

$$ PLATE 15          DRAWING AN AUXILIARY VIEW-STRUT ANCHOR
                    ALPHAP/(.2,.2,.2,0),(0,0,0,0)
                    TITLE /6,1.5,@PLATE 15@
                    SCALE /1/2
FRONT              =   VIEW /
                    ORIGIN/4.5,2+1+11/16
                    LN      /DX,9/16
LXX                =   LN      /DY,1+11/16
PX5                =   PT      /PPP
P1                 =   POINT  /9/16,1+11/16-7/16
                    CONSTR,LN  /P1,ATANGL,120,TILLY,1+11/16+1+3/8
P2                 =   PT      /PPP
                    CONSTR,LN  /(POINT/P2),ATANGL,30,LENGTH,1.875/2
P3                 =   PT      /PPP
                    LN      /.562,1.687,DX,1.687+1.5+1.5
PX1                =   PT      /PPP
P4                 =   LN      /DY,.562
P5                 =CONSTR,LN  /(POINT/P3),ATANGL,300,TILLY,2.25
                    LN      /(POINT/P4),(POINT/P5)
                    LN      /(POINT/P5),(POINT/P3)
                    LN      /(POINT/P3),ATANGL,210,LENGTH,1.875
PX                 =   PT      /PPP
                    CONSTR,LN  /PX,ATANGL,120,LENGTH,3
P11                =   PT      /PPP
                    CONSTR,LN  /P11,ATANGL,300,LENGTH,3
                    LN      /PPP,ATANGL,300,TILLX,0
                    LN      /PPP,ATANGL,270,TILLY,0
                    CONSTR,LN  /(PT/P2),ATANGL,210,LENGTH,.562
PY                 =   PT      /PPP
                    DASHED,LN  /PPP,ATANGL,300,LENGTH,1.125
PX2                =   PT      /PPP
                    DASHED,LN  /PPP,ATANGL,30,LENGTH,1.125
                    DASHED,LN  /PPP,ATANGL,120,LENGTH,1.125
P6                 =CONSTR,LN  /(PT/P2),ATANGL,120,LENGTH,.25
P7                 =CONSTR,LN  /(PT/P1),ATANGL,300,LENGTH,.25
                    CTRLN ,LN  /(PT/P7),(PT/P6)
                    CTRLN ,LN  /2.25,1.687-.25,DY,1.125
                    CTRLN ,LN  /3.75,2.5,DY,-1.125
PX3                =   PT      /1.875,1.687
                    DOTTED,LN  /1.875,1.687,DY,.562
                    CONSTR,LN  /DX,2.25
                    DOTTED,LN  /DY,-.562
PX4                =   PT      /PPP
                    END      /FRONT
                    DRAW     /FRONT
                    MASK     /@P,F16@
                    DIMP     /2,.1,2,2
                    DIMST    /XLARGE,YCOMP,PX1,(PT/P4),.25
                    DIM      /PX1,(PT/P4)
                    DIMST    /XLARGE,YCOMP,LXX
                    DIMNE    ,PX5,P2
                    DIMP     /.5,.1,2,2

```

```

DIMST /YLARGE,TRUE,PX,P3,.25
DIM /PX,P3
DIMP /2,.1,2,2
DIMST /YSMALL,TRUE,PY,PX2,.50
DIM /PY,PX2
TOP = VIEW /
DIST1 = DIST((PT/P4),(PT/P5))
P8 = PT /-(DIST1+.25),-1.5
LN /P8,DX,DIST1+.25-1.5
ARC /-1.5,0,1.5,270,180
P9 = LN /PPP,DX,-(DIST1+.375-1.5)
LN /(PT/P9),DY,-1.125
P10 = LN /PPP,ATANGL,30,LENGTH,.125
LN /P8,DY,1.125
LN /PPP,ATANGL,210,LENGTH,.125
LN /PPP,(PT/P10)
L1 =CTRLN ,LN /-3.625,0,DX,3.875
CTRLN ,LN /-3,-1.75,DY,3.5
L2 =CTRLN ,LN /-1.5,1.75,DY,-3.5
LN /-1.5,-.375,DX,-1.5
ARC /-3,0,.375,270,-180
LN /DX,1.5
ARC /-1.5,0,.375,90,-180
PX6 = PT /XLARGE,INTOF,L1,L2
END /TOP
ORIGIN/7.125,5.5+1+11/16
DRAW /TOP
ALPHAP/(.1,.1,.1,0),(0,.1,0,-5)
NOTER /PX6,-1,1.5,@FROM ARC CENTERS IS 1.5@,$
@ARE 3/8, AND DISTANCES@,@ ARCS IN THIS SLOT@
SIDE = VIEW /
REFSYS/P11,ATANGL,30
LN /0,0,DX,1+7/8
LN /PPP,DY,3
LN /PPP,DX,-1-7/8
LN /PPP,DY,-3
LN /6/16,9/16,DX,1+1/8
LN /PPP,DY,1+7/8
LN /PPP,DX,-1-1/8
LN /PPP,DY,-1-7/8
END /SIDE
ORIGIN/4.5,2+1+11/16
DRAW /SIDE

```

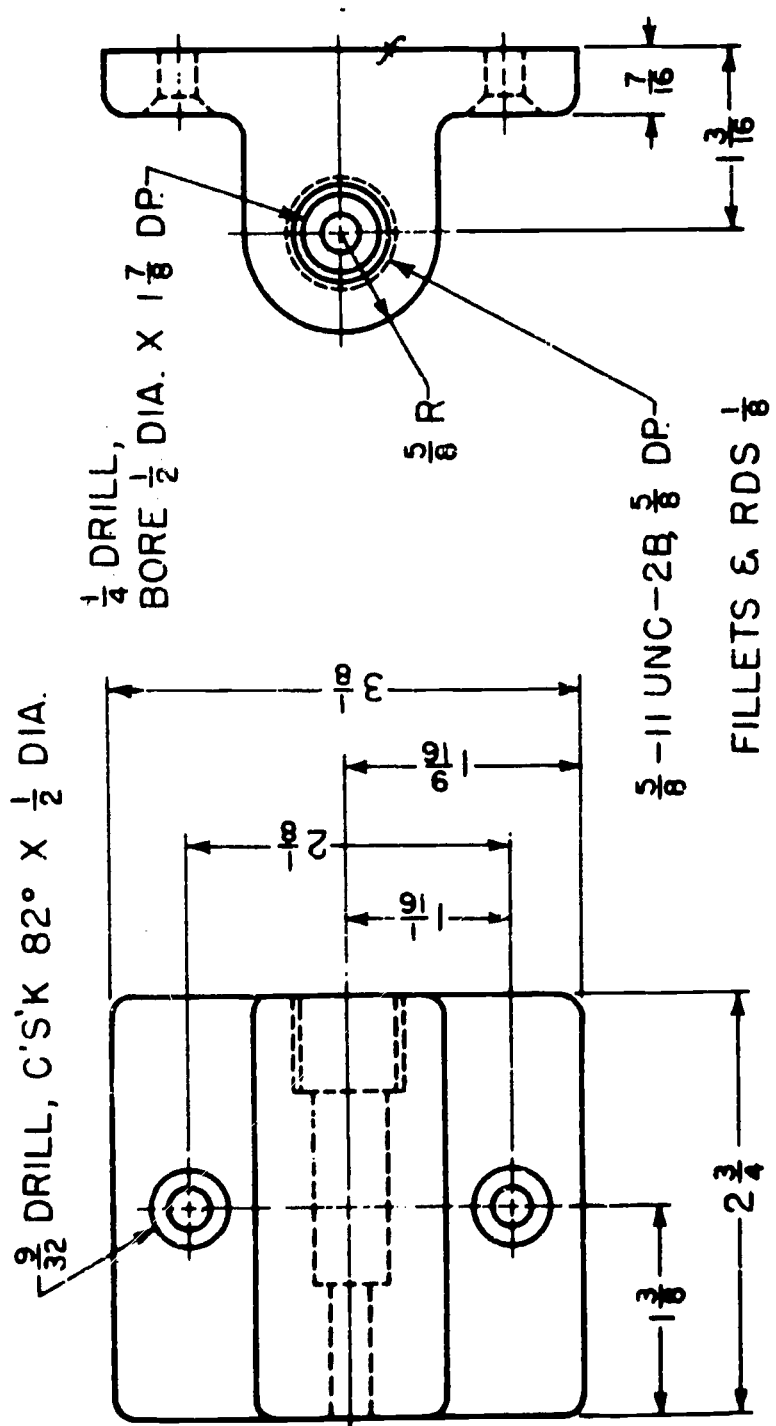

SKETCH 16

1967 SUMMER INSTITUTE

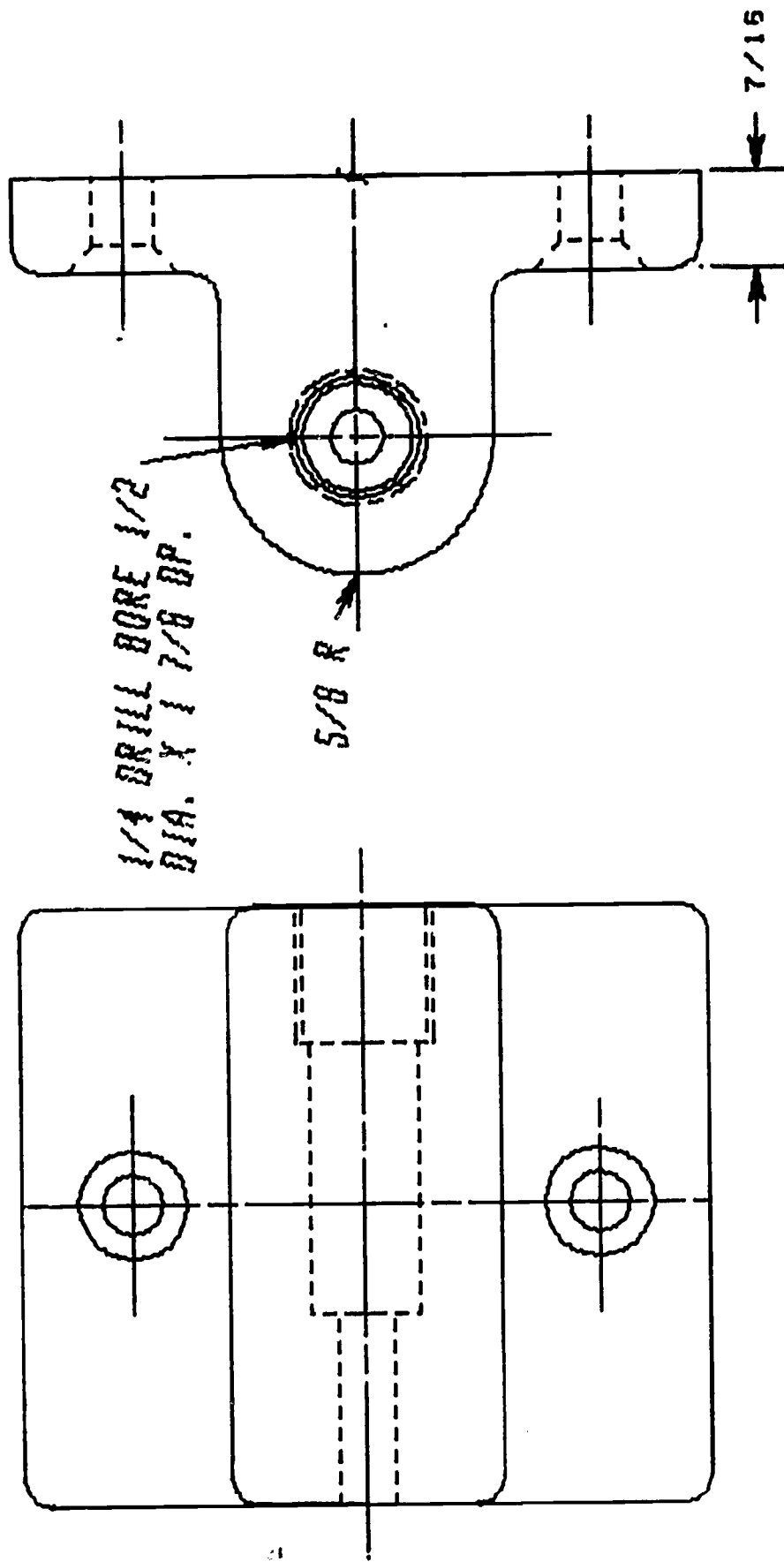

PLATE 16

1967 SUMMER INSTITUTE
MIAMI-DADE JUNIOR COLLEGE

*** 1967 SUMMER INSTITUTE

```

$$ PLATE 16      TWO VIEW DRAWING USING FILLETS  (LONG -X-)
TOP      =      VIEW /
          LN      /0,3,DY,-3
          ARC     /.125
          LN      /DX,2.75
          ARC     /.125
          LN      /DY,3.125
          ARC     /.125
          LN      /DX,-2.75
          ARC     /.125
          LN      /DY,-.125
          LN      /0,1.562,DY,.625
          ARC     /.125
          LN      /DX,2.75
          ARC     /.125
          LN      /DY,-1.25
          ARC     /.125
          LN      /DX,-2.75
          ARC     /.125
          LN      /DY,.125
          CTRLN ,LN /-.25,1.562,DX,2.75+.5
L1      =CTRLN ,LN /1.375,2.625+.5,DY,-3.125
L2      =CTRLN ,LN /1.375-.5,.5,DX,1
L3      =CTRLN ,LN /1.375-.5,2.625,DX,1
P1      =      PT   /INTOF,L1,L2,,P2=PT/INTOF,L1,L3
          CR     /P1,9/64
          CR     /P1,.25
          CR     /P2,9/64
CO      =      CR     /P2,.25
PW      =      PT   /YLARGE,INTOF,L1,CO
          END    /TOP
          ORIGIN/3,2.188
          DRAW   /TOP
          ALPHAP/(.1,.2,.1,0),(0,-.2,0,-15)
          @ 82$DG$ X 1/2 DIA.@
HOLE    =DOTTED,VIEW /
          LN      /0,.125,DX,2.75-1.875
          LN      /2.75-1.875,0,DY,.25
          LN      /DX,1.875-.625
          LN      /2.75-.625,0,DY,5/16
          LN      /DX,.625
          CONSTR,LN /DY,-1/32
          LN      /DX,-.625
          END    /HOLE
          ORIGIN/3,3.75
          DRAW   /HOLE
          DRAW   /MIRY(HOLE)
SIDE    =      VIEW /
L4      =CTRLN ,LN /-(.625+.25),0,DX,.625+1.187+.5
L5      =CTRLN ,LN /0,.625+.25,DY,-(.625*2+.5)
P3      =      PT   /INTOF,L4,L5
          CR     /P3,.125

```

```

C1      =      CR      /P3,.25
          =      CR      /P3,.312-1/32
          =      DOTTED, CR      /P3,.312
          =      ARC      /P3,.625,90,180
          =      LN      /DX,1.187-.437
          =      ARC      /.125
          =      LN      /DY,-(1.562-.625)
P6      =      PT      /PPP
          =      ARC      /.125
          =      LN      /DX,.437
P7      =      PT      /PPP
          =      LN      /DY,3.125/2
PFN     =      PT      /PPP,,PX=PT/YLARGE,INTOF,L5,C1
          =      LN      /PFN,DY,3.125/2
          =      LN      /DX,-.437
          =      ARC      /.125
          =      LN      /DY,-(1.562-.625)
          =      ARC      /.125
          =      LN      /DX,-(1.187-.437)
          =      END      /SIDE
          =      ORIGIN/7.875,3.75
          =      DRAW      /SIDE
          =      NOTER /PX,-.125,.75,@1/4 DRILL BORE 1/2@,$
          =      @DIA. X 1 7/8 DP.@
          =      NOTER /-5/8,0,-.25,.125,@5/8 R@
          =      NOTE  /PFN,@$FN$@
          =      MASK  /@P,F16@
          =      DIMP  /2,.1,2,2
          =      DIMST /YSMALL,XCOMP,P6,P7,.25
          =      DIM   /P6,P7
CSINK   =DOTTED,VIEW /
          =      CTRLN ,LN /1.187-(.437+.25),1.062,DX,.437+.5
P5      =      LN      /1.187-.437,1.062+.25,ATANGL,139,$
          =      TILLY,1.062+9/64
          =      LN      /PPP,ATANGL,0,TILLX,1.187
          =      LN      /1.187-.437,1.062-.25,ATANGL,221,$
          =      TILLY,1.062-9/64
          =      LN      /PPP,ATANGL,0,TILLX,1.187
          =      LN      /(POINT/P5),DY,-9/32
          =      END      /CSINK
          =      ORIGIN/7.875,3.75
          =      DRAW      /CSINK
          =      DRAW      /MIRY(CSINK)
          =      FINI     /

```

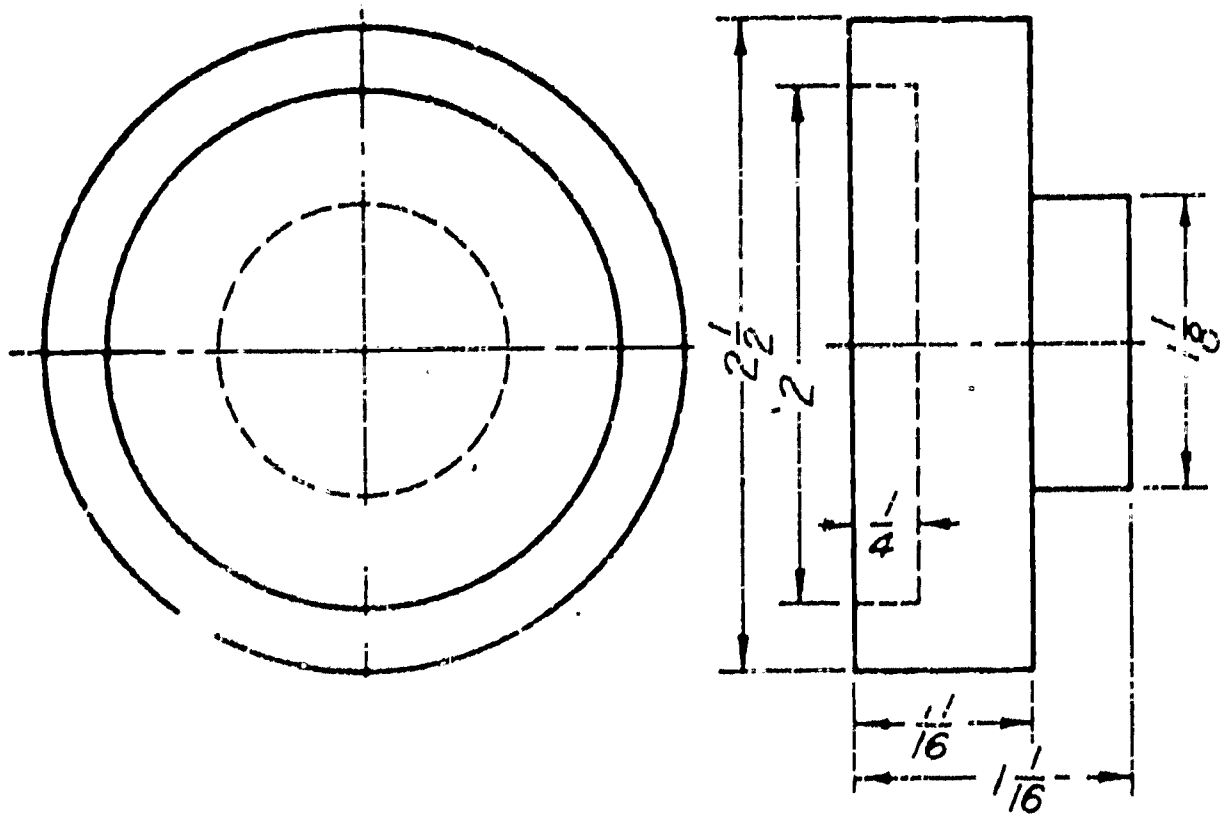

SKETCH 17
1967 SUMMER INSTITUTE

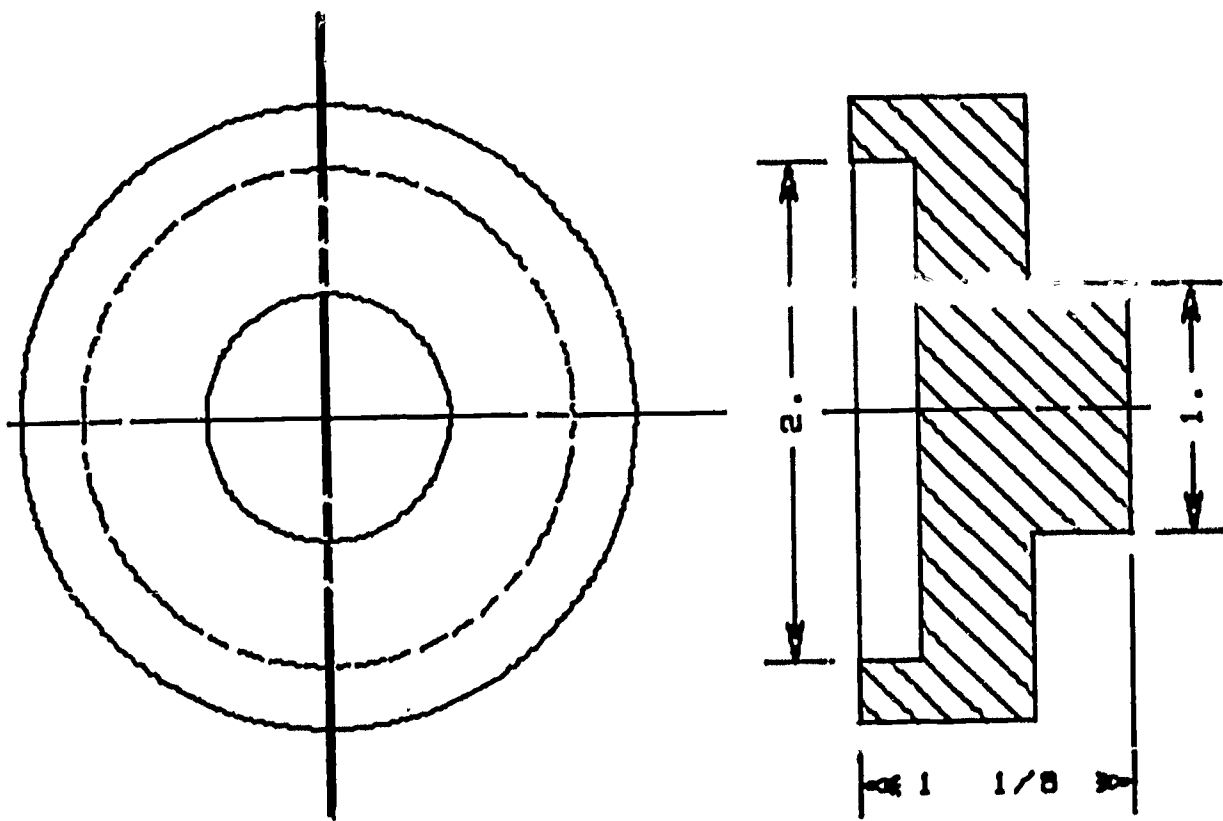

PLATE 17

1967 SUMMER INSTITUTE
MIAMI-DADE JUNIOR COLLEGE

***** 1967 SUMMER INSTITUTE

```

$$ PLATE 17          INTRODUCTION TO CROSS HATCHING
VITOP =             VIEW /
                   ORIGIN/3.75,5.875
CUTPL ,LINE /0,-1.6,DY,3.2
CTRLN ,LINE /0,0,DX,-1.3
CTRLN ,LINE /0,0,DX,1.6
CTRLN ,LINE /2,0,DX,1.3
                   CIRCLE/0,0,.5
DOTTED,CIRCLE/0,0,1
                   CIRCLE/0,0,1.25
                   END /VITOP
                   DRAW /VITOP

VISEC =             VIEW /
P1 =               PT /2.125,1
                   LINE /P1 ,DY,.25
P2 =               PT /PPP
                   LINE /PPP,DX,.7
P3 =               PT /PPP
                   LINE /PPP,DY,-.75
                   LINE /PPP,DX,.4
P4 =               PT /PPP
L1 =               LINE /PPP,DY,-1
P5 =               PT /PPP
                   LINE /PPP,DX,-.4
                   LINE /PPP,DY,-.75
P6 =               PT /PPP
L3 =               LINE /PPP,DX,-.7
P7 =               PT /PPP
                   LINE /PPP,DY,.25
P8 =               PT /PPP
                   LINE /PPP,DX,.25
P9 =               PT /PPP
                   LINE /PPP,DY,2
P10 =              PT /PPP
L4 =               LINE /PPP,P1
                   END /VISEC
                   DRAW /VISEC
                   HATCHP/135,.1,0,0
                   HATCH /VISEC
                   MASK /@PF08TN@
                   DIMST /XLARGE,YCOMP,L1,.25
                   DIMP /.5,.1,1,1
                   DIM /P5,P4
                   MASK /@PF00TN@
                   DIMST /XSMALL,YCOMP,P1,P8,.25
                   DIM /P1,P8
                   MASK /@PF16TN@
                   DIMST /YSMALL,XCOMP,L3,.25
                   DIMP /L3
                   DIMP /.5,.1,1,1
                   DIM /P7,P5

V =               VIEW /

```

LINE /P1,DY,-2
END /V
DRAW /V
FINI /

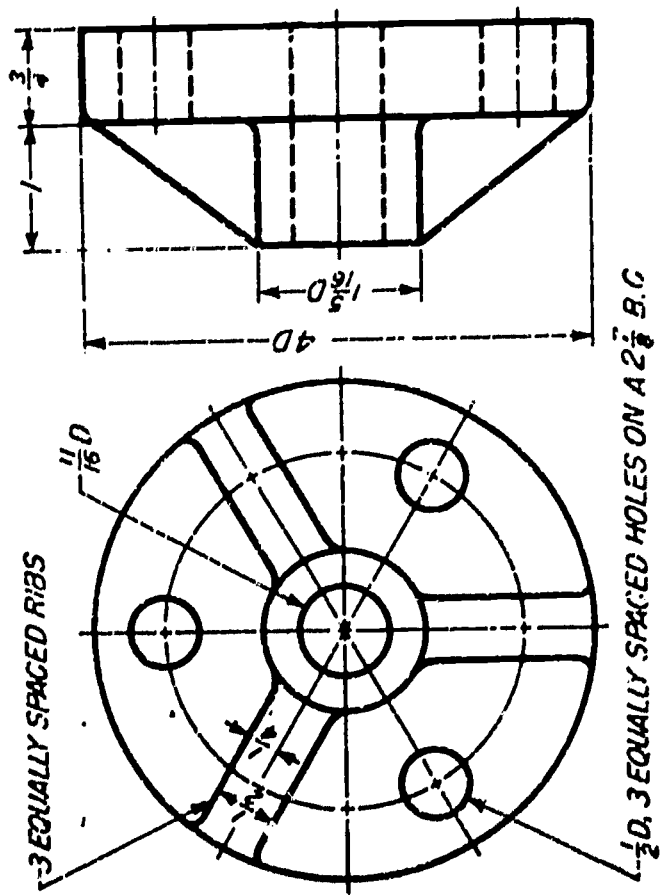

SKETCH 18
1967 SUMMER INSTITUTE

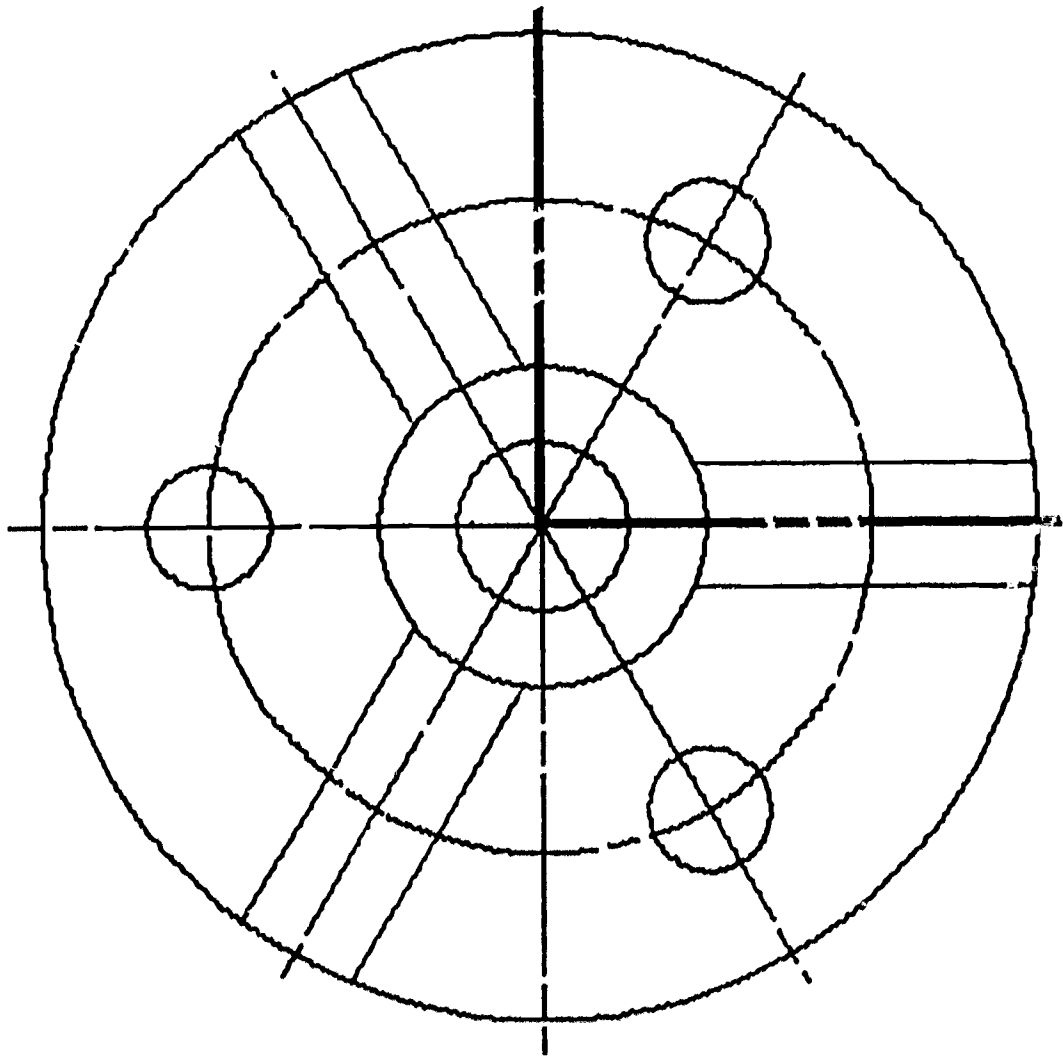
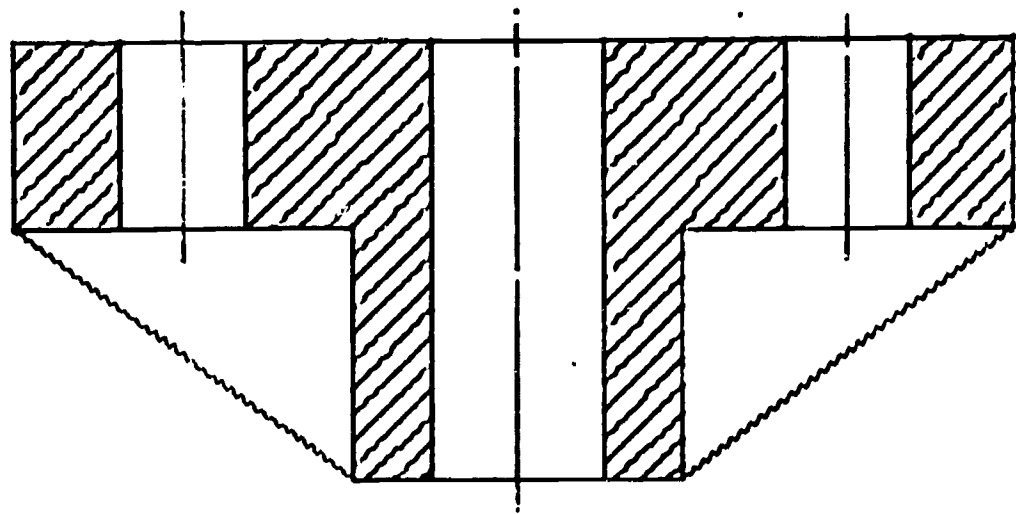

PLATE 18

1967 SUMMER INSTITUTE
MIAMI-DADE JUNIOR COLLEGE

***** 1967 SUMMER INSTITUTE

\$\$ PLATE 18

HATCHING A SHAFT GUIDE

(LONG -X-)

```

ALPHAP/(.2,.2,0,-.2),(0,0,0,270)
TITLE /1.5,2.5,@PLATE 18@
SHAFT = VIEW /
ORIGIN/4.25,3.75
C1 = CR /0,0,11/32
C2 = CR /0,0,21/32
C3 = CR /0,0,2
C4 =CTRLN ,CR /0,0,1+21/64
CNTERY =CUTPL ,LN /0,0,ATANGL,270,LENGTH,2.125
LNR =CONSTR,LN /XLARGE,PARLEL,CNTERY,.25
LNL =CONSTR,LN /XSMALL,PARLEL,CNTERY,.25
PRR1 = PT /YSMALL,INTOF,LNR,C2
PRR2 = PT /YSMALL,INTOF,LNR,C3
PRL1 = PT /YSMALL,INTOF,LNL,C2
PRL2 = PT /YSMALL,INTOF,LNL,C3
LN /PRR1,PRR2
LN /PRL2,PRL1
LOOPST/

N=30
1)CNTER1 =CTRLN ,LN /0,0,ATANGL,N,LENGTH,2.125
LNRIGT =CONSTR,LN /XLARGE,PARLEL,CNTER1,.25
PRGT1 = PT /YLARGE,INTOF,LNRIGT,C2
PRGT2 = PT /YLARGE,INTOF,LNRIGT,C3
LN /PRGT1,PRGT2

N=N+120
IF(N-150)1,1,2
2) LOOPND/
LOOPST/

N=30
1)CNTERX =CONSTR,LN /0,0,ATANGL,N,LENGTH,2.125
LNLEFT =CONSTR,LN /XSMALL,PARLEL,CNTERX,.25
PLFT1 = PT /YLARGE,INTOF,LNLEFT,C2
PLFT2 = PT /YLARGE,INTOF,LNLEFT,C3
LN /PLFT1,PLFT2

N=N+120
IF(N-150)1,1,2
2) LOOPND/
LOOPST/

N=210
1)L3 =CTRLN ,LN /0,0,ATANGL,N,LENGTH,2.125
P5 = PT /YSMALL,INTOF,L3,C4
CR /P5,.25

N=N+120
IF(N-330)1,1,2
2) LOOPND/
LX4 =CTRLN ,LN /0,0,ATANGL,90,LENGTH,2.125
PX6 = PT /YLARGE,INTOF,LX4,C4
CR /PX6,.25
CTRLN ,LN /0,0,DX,-2.125
CUTPL ,LN /0,0,DX,2.125
END /SHAFT

```

```

SHAFT1 = DRAW /SHAFT
VIEW /
LN /3.5,21/32,DY,-21/16
P1 = PT /PPP
LN /PPP,DX,1
P2 = PT /PPP
LN /PPP,DY,-(2-21/32)
P3 = PT /PPP
LN /PPP,DX,3/4
P4 = PT /PPP
LN /PPP,DY,4
P5 = PT /PPP
LN /PPP,DX,-3/4
P6 = PT /PPP
LN /PPP,DY,-(2-21/32)
P7 = PT /PPP
LN /PPP,DX,-1
P8 = PT /PPP
P9 = PT /3.5,11/32
LN /P9,DX,1.75
P10 = PT /PPP
CONSTR,LN /PPP,DY,-11/16
P11 = PT /PPP
LN /P11,DX,-1.75
P12 = PT /PPP
LN /P1,P3
P13 = PT /4.5,-(1.75-43/64)
LN /P13,DX,.75
P14 = PT /PPP
CONSTR,LN /P14,DY,-.5
P15 = PT /PPP
LN /P15,DX,-.75
P16 = PT /PPP
P17 = PT /4.5,(1.75-43/64)
LN /P17,DX,.75
P18 = PT /PPP
CONSTR,LN /P18,DY,.5
P19 = PT /PPP
LN /P19,DX,-.75
P20 = PT /PPP
LN /P6,P8
CTRLN ,LN /3.375,0,DX,2.0
CTRLN ,LN /4.375,-(2-43/64),DX,1.0
CTRLN ,LN /4.375,(2-43/64),DX,1.0
END /SHAFT1
DRAW /SHAFT1
SHAFT2 = VIEW /
CONSTR,LN /P15,P16
CONSTR,LN /P16,P3
CONSTR,LN /P3,P4
CONSTR,LN /P4,P15
CONSTR,LN /P10,P18
CONSTR,LN /P18,P17
CONSTR,LN /P17,P7
CONSTR,LN /P7,P8

```

```
CONSTR, LN    /P8, P9
CONSTR, LN    /P9, P10
              END    /SHAFT2
              DRAW   /SHAFT2
              HATCHP /135, .075, 0, 0
              HATCH  /SHAFT2
SHAFT3 =      VIEW  /
              CONSTR, LN    /P20, P19
              CONSTR, LN    /P19, P5
              CONSTR, LN    /P5, P6
              CONSTR, LN    /P6, P20
              CONSTR, LN    /P12, P11
              CONSTR, LN    /P11, P14
              CONSTR, LN    /P14, P13
              CONSTR, LN    /P13, P2
              CONSTR, LN    /P2, P1
              CONSTR, LN    /P1, P12
              END    /SHAFT3
              DRAW   /SHAFT3
              HATCHP /135, .075, 0, 0
              HATCH  /SHAFT3
              FINI  /
```

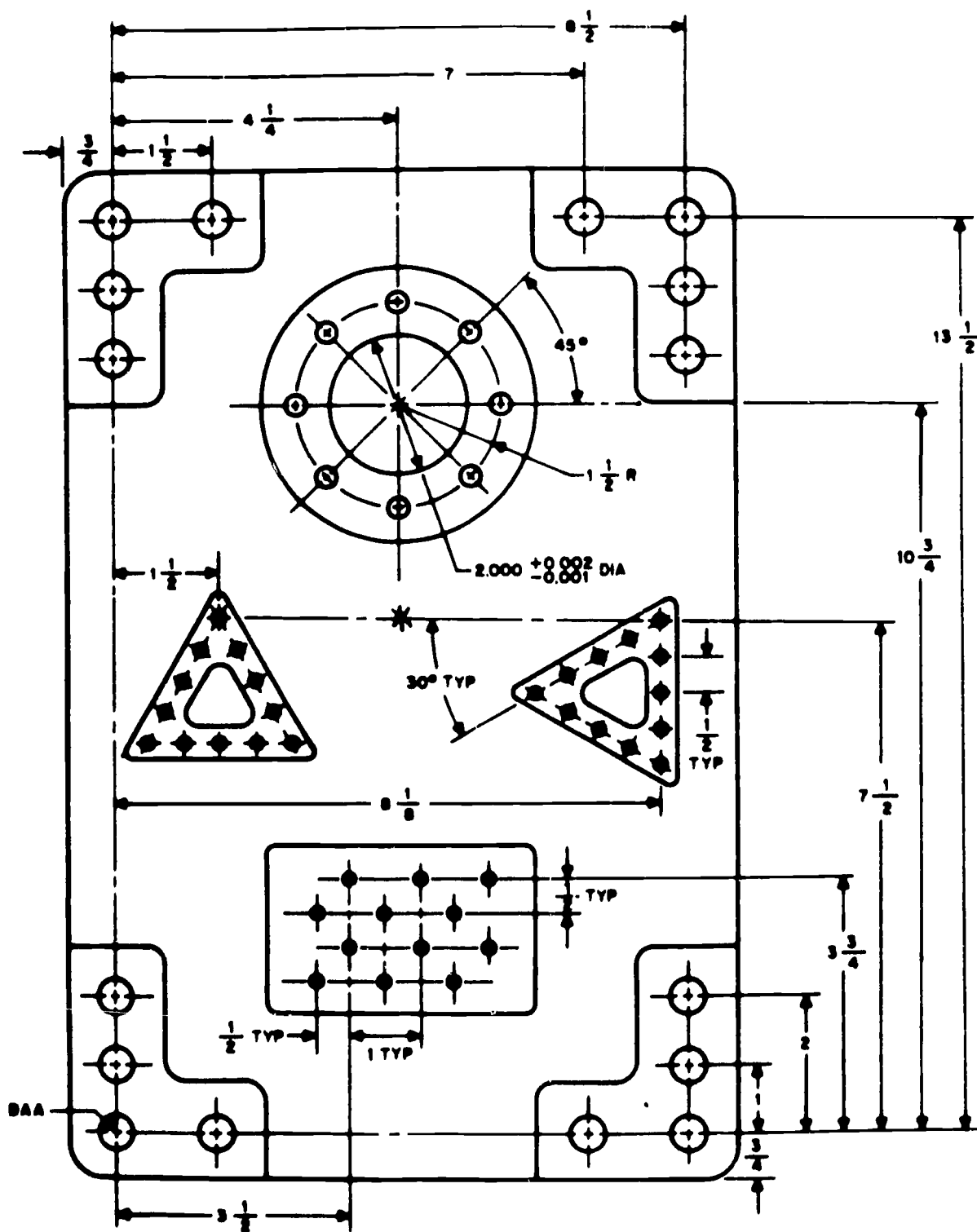

SKETCH 19

1967 SUMMER INSTITUTE

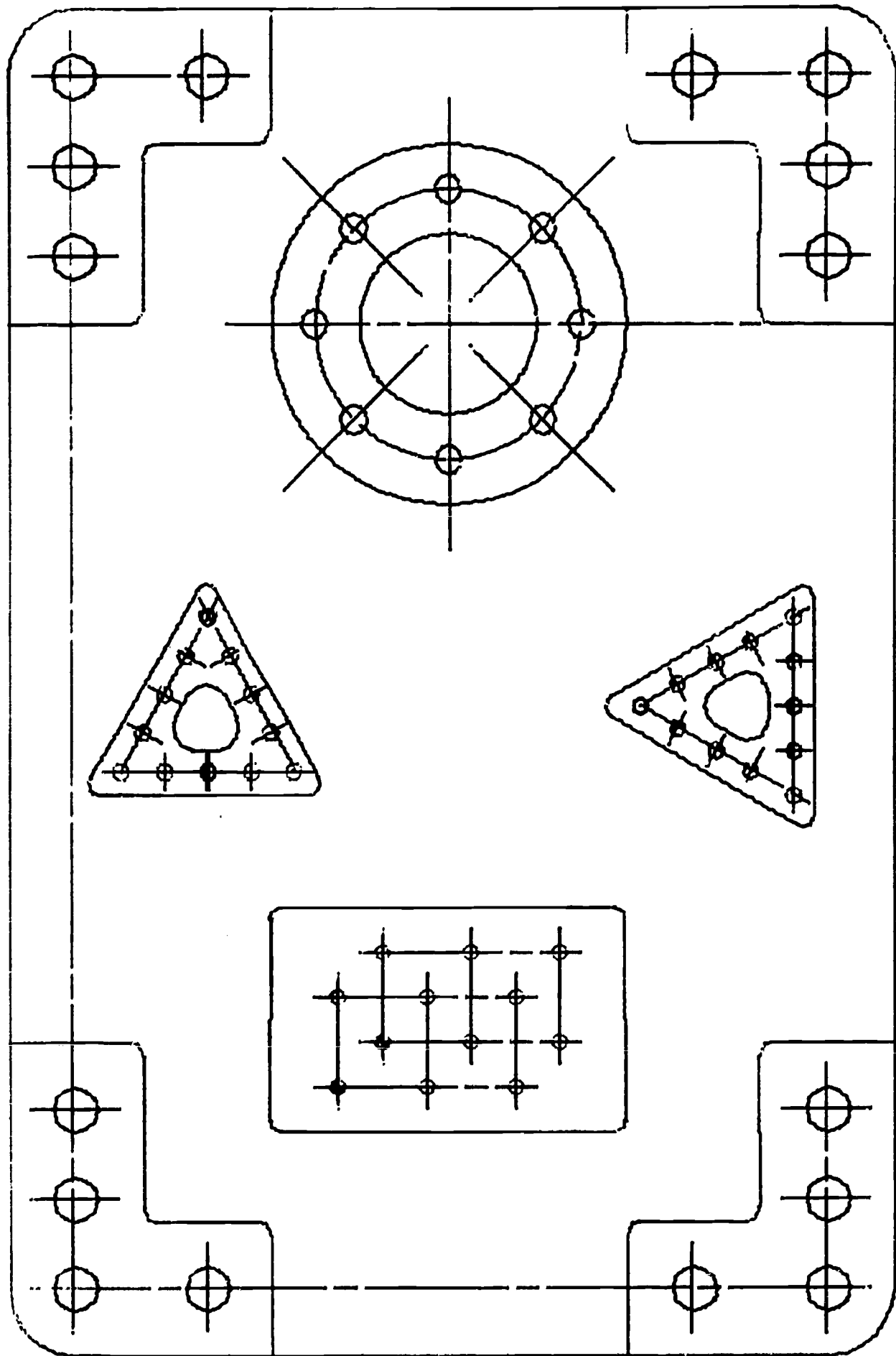

PLATE 19

1967 SUMMER INSTITUTE
MIAMI-DADE JUNIOR COLLEGE

***** 1967 SUMMER INSTITUTE

\$\$ PLATE 19

MOUNTING PLATE

FRAMEX =

ALPHAP/(.2,.2,.2,0),(0,0,0,0)
TITLE /6,1.5,@PLATE 19@
SCALE /.5
VIEW /
LINE /01,0,DX,9
ARC /0.75
LINE /DY,15
ARC /0.75
LINE /DX,-10
ARC /0.75
LINE /DY,-15
ARC /0.75
LINE /DX,1
END /FRAMEX
ORIGIN/2.25,2.125
DRAW /FRAMEX

CORNER =

VIEW /
LINE /2,7.5,DY,-1.50
ARC /5/32
LINE /DX,1.5
ARC /5/32
LINE /DY,-2
ARC /5/32
LINE /DX,1.5
END /CORNER
ORIGIN/4.75,5.875
DRAW /CORNER
DRAW /MIRX(CORNER)
DRAW /MIRY(CORNER)
DRAW /MIRXY(CORNER)

CHOLE =CTRLN ,

VIEW /
LINE /0,-.5,DY,14.5
LINE /-5,13.5,DX,2.5
LINE /7-1/2,13.5,DX,2.5
LINE /9,12.5,DX,-1
LN /1/2,12.5,DX,-1
LN /-1/2,11.5,DX,1
LN /8,11.5,DX,1
LN /9,2,DX,-1
LN /1/2,2,DX,-1
LN /-1/2,1,DX,1
LN /8,1,DX,1
LN /9,0,DX,-9.5
LN /1.5,-1/2,DY,1
LN /7,1/2,DY,-1
LN /8.5,-1/2,DY,3
LN /8.5,11,DY,3
LN /7,14,DY,-1
LN /1.5,13,DY,1
END /CHOLE
ORIGIN/2.615,2.5

```

SMLCIR =      DRAW /CHOLE
              VIEW /
              ORIGIN/4.75,5.875
              CIRCLE/4.25,6.75,.25
              CIRCLE/4.25,5.75,.25
              CIRCLE/4.25,4.75,.25
              CIRCLE/2.75,6.75,.25
              END /SMLCIR
              DRAW /SMLCIR
              DRAW /MIRX(SMLCIR)
              DRAW /MIRY(SMLCIR)
              DRAW /MIRXY(SMLCIR)
LGCIR =      VIEW /
              ORIGIN/4.75,7.875
              CIRCLE/0,0,1.
              CIRCLE/0,0,2.
C1 =CTRLN ,CIRCLE/0,0,1.5
          CTRLN ,LN /0,-2.5,DY,5.
          CTRLN ,LN /-2.5,0,DX,6.
              END /LGCIR
              DRAW /LGCIR
LGCIRL =     VIEW /
              ORIGIN/4.75,7.875
L1 =CTRLN ,LN /.25,.25,ATANGL,45,LENGTH,2.25
              END /LGCIRL
              DRAW /LGCIRL
              DRAW /MIRX(LGCIRL)
              DRAW /MIRY(LGCIRL)
              DRAW /MIRXY(LGCIRL)
CIRMIR =    VIEW /
              ORIGIN/4.75,7.875
              CIRCLE/(POINT/XLARGE,INTOF,L1,C1),.3125/2
              END /CIRMIR
              DRAW /CIRMIR
              DRAW /MIRX(CIRMIR)
              DRAW /MIRY(CIRMIR)
              DRAW /MIRXY(CIRMIR)
CIRTOP =   VIEW /
              ORIGIN/3.75,7.875
              CIRCLE/2,1.5,.3125/2
              END /CIRTOP
              DRAW /CIRTOP
              DRAW /MIRY(CIRTOP)
CIRSID =   VIEW /
              ORIGIN/4.75,6.875
              CIRCLE/1.5,2,.3125/2
              END /CIRSID
              DRAW /CIRSID
              DRAW /MIRX(CIRSID)
BOX =      VIEW /
              ORIGIN/2.615,2.5
              LN /2.375,1.750,DX,3.875
              ARC /.125
              LN /DY,2.5
              ARC /.125

```

```

LN      /DX,-4.
ARC     /.125
LN      /DY,-2.5
ARC     /.125
LN      /DX,.125
CTRLN ,LN /2.75,2.25,DX,2.5
CTRLN ,LN /2.75,3.25,DX,2.5
CTRLN ,LN /3.25,2.75,DX,2.5
CTRLN ,LN /3.25,3.75,DX,2.5
END     /BOX
DRAW    /BOX
BOXCIR= VIEW /
        ORIGIN/3.75,4.125
        CIRCLE/1.25,.5,.152/2
        CIRCLE/2.25,.5,.152/2
        CIRCLE/3.25,.5,.152/2
        LN      /1.25,.75,DY,-.75
        LN      /2.25,.75,DY,-.75
        LN      /3.25,.75,DY,-.75
        END     /BOXCIR
        DRAW    /BOXCIR
        DRAW    /MIRY(BOXCIR)
BIXSIR= VIEW /
        ORIGIN/3.75,3.875
        CIRCLE/.75,.5,.152/2
        CIRCLE/1.75,.5,.152/2
        CIRCLE/2.75,.5,.152/2
        LN      /.75,.75,DY,-.75
        LN      /1.75,.75,DY,-.75
        LN      /2.75,.75,DY,-.75
        END     /BIXSIR
        DRAW    /BIXSIR
        DRAW    /MIRY(BIXSIR)
LFTRI = VIEW /
        ORIGIN/3.375,5.3845
L2      =CTRLN ,LN /0,0,DX,1.2
L3      =CTRLN ,LN /1,0,ATANGL,120,TILLX,-.173
        CONSTR,LN /1,0,ATANGL,320,TILLY,-.1
        LN      /0,-.2,DY,.4
        LN      /.5,-.2,DY,.4
        CR      /0,0,.164/2
        CR      /.5,0,.164/2
        CR      /1,0,.164/2
L4      =CONSTR,LN /-.5,0,ATANGL,60,TILLY,7.5
L5      =CONSTR,LN /0,0,ATANGL,60,TILLY,7.5
L6      =CONSTR,LN /.5,0,ATANGL,60,TILLY,7.5
        CR      /(POINT/XLARGE,INTOF,L3,L4),.164/2
        CR      /(POINT/XLARGE,INTOF,L3,L5),.164/2
        CR      /(POINT/XLARGE,INTOF,L3,L6),.164/2
        CR      /0,SQRT(3),.164/2
        CONSTR,LN /(POINT/XLARGE,INTOF,L3,L4),ATANGL,$
        30,TILLX,.423
        LN      /PPP,ATANGL,210,TILLX,.047
        CONSTR,LN /(POINT/XLARGE,INTOF,L3,L5),ATANGL,$
        30,TILLX,.673

```



```

          LN      /PPP,ATANGL,210,TILLX,.327
CONSTR, LN      /(POINT/XLARGE,INTOF,L3,L6),ATANGL,$
              30,TILLX,.923
          LN      /PPP,ATANGL,210,TILLX,.547
          END      /LFTRI
          DRAW     /LFTRI
          DRAW     /MIRX(LFTRI)
LFFIN=        VIEW /
              ORIGIN/2.615,2.5
          LN      /.5,5.517,DX,2.4325
          ARC      /.125
          LN      /PPP,ATANGL,120,TILLX,1.5
          ARC      /.125
          LN      /PPP,ATANGL,240,TILLY,5.517
          ARC      /.125
          LN      /DX,.55
          LN      /1.333,6.017,DX,.7345
          ARC      /.25
          LN      /PPP,ATANGL,120,TILLX,1.5
          ARC      /.25
          LN      /PPP,ATANGL,240,TILLY,6.017
          ARC      /.25
          LN      /DX,.4005
          END      /LFFIN
          DRAW     /LFFIN
          VIEW     /
RGTRI =      ORIGIN/5.82135,5.75
L7 =CTRLN   ,LN      /0,0,ATANGL,30,TILLY,1.1
L8 =CTRLN   ,LN      /SQRT(3),1.2,DY,-1.2
              CR      /0,0,.082
L9 =         LN      /.3325,.423,ATANGL,300,TILLX,.5325
              CR      /(POINT/XLARGE,INTOF,L7,L9),.082
L10 =       LN      /.765,.673,ATANGL,300,TILLX,.965
              CR      /(POINT/XLARGE,INTOF,L7,L10),.082
L11 =       LN      /1.1975,.823,ATANGL,300,TILLX,1.3975
              CR      /(POINT/XLARGE,INTOF,L7,L11),.082
              CR      /(POINT/XLARGE,INTOF,L7,L8),.082
L12 =       LN      /SQRT(3)-.2,.5,DX,.4
              CR      /(POINT/XLARGE,INTOF,L8,L12),.082
L13 =       LN      /SQRT(3)-.2,0,DX,.4
              CR      /(POINT/XLARGE,INTOF,L8,L13),.082
          END      /RGTRI
          DRAW     /RGTRI
          DRAW     /MIRY(RGTRI)
          VIEW     /
RGFIN =      ORIGIN/2.615,2.5
          LN      /6.3927,6.5+.25/SIND(60),ATANGL,30,$
              TILLX,8.375
          ARC      /.125
          LN      /DY,-2.865
          ARC      /.125
          LN      /PPP,ATANGL,150,TILLY,6.5
          ARC      /.125
          LN      /PPP,ATANGL,30,TILLX,6.3927
          LN      /7.25,.3575*SIND(30)/COSD(30)+6.5,$

```

ATANGL,30,TILLX,7.875
ARC /.25
LN /PPP,ATANGL,270,TILLY,\$
.25*COSD(30)/SIND(30)+5.5
ARC /.25
LN /PPP,ATANGL,150,TILLX,6.8927
ARC /.25
LN /PPP,ATANGL,30,TILLX,7.2500
END /RGFIN
DRAW /RGFIN
FINI/

TOTAL BACHELOR DEGREES AND DEGREES IN SCIENCE AND ENGINEERING

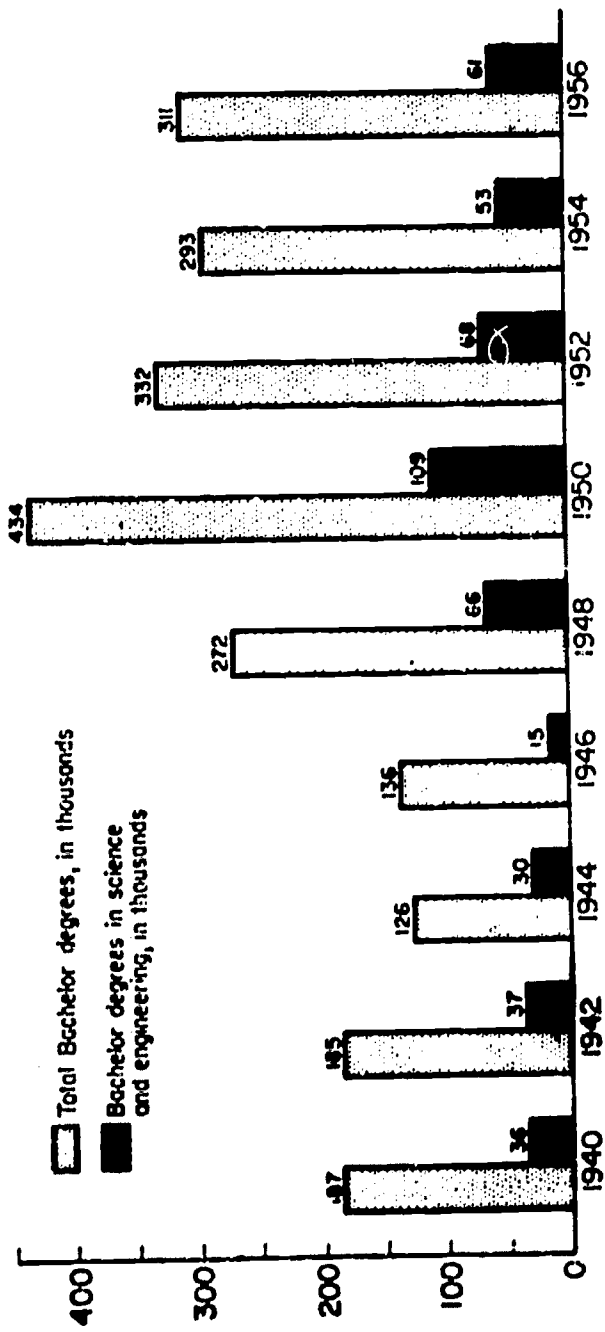

SKETCH 20

1967 SUMMER INSTITUTE

TOTAL BACHELOR DEGREES AND DEGREES IN SCIENCE AND ENGINEERING

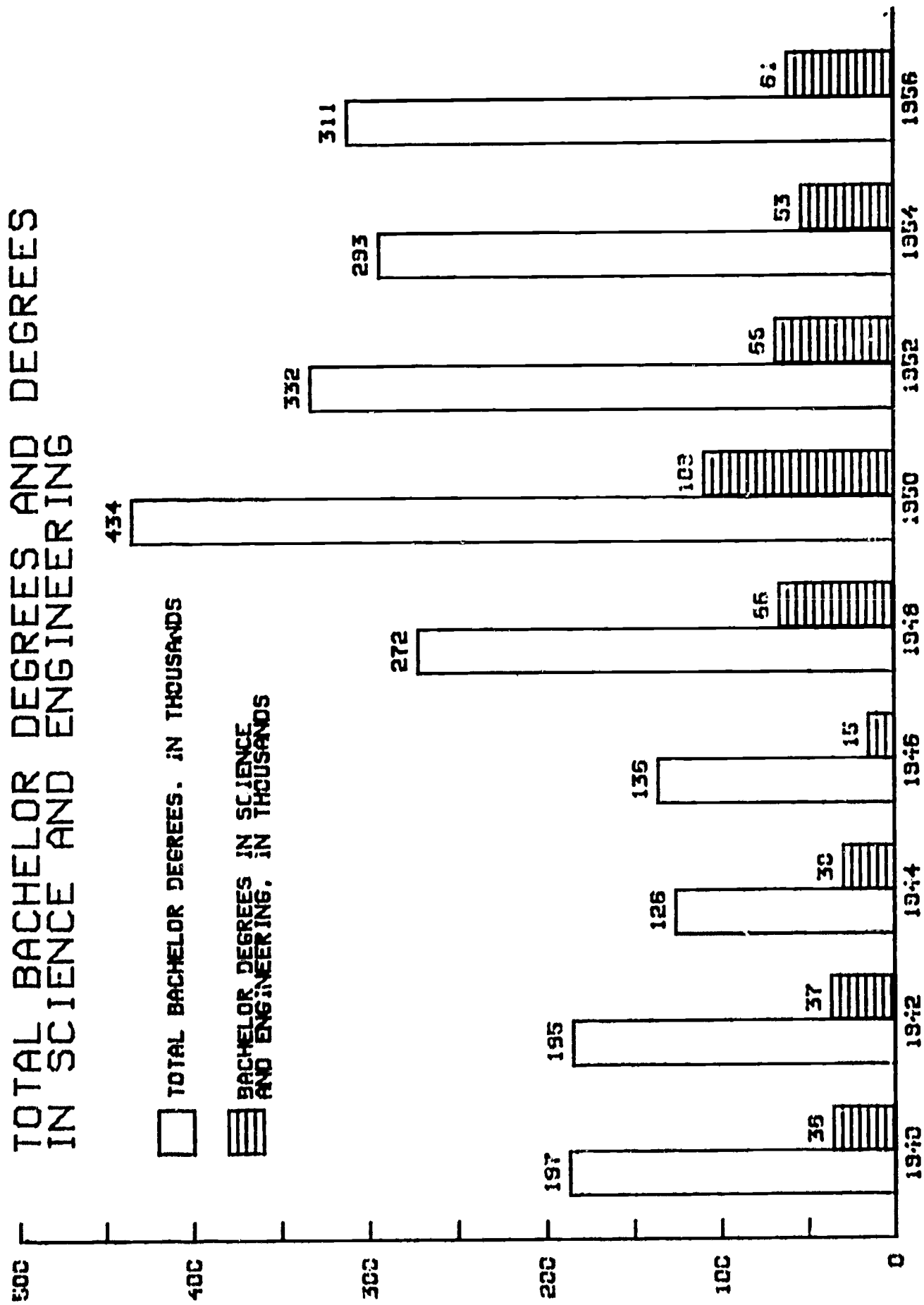

PLATE 20

1967 SUMMER INSTITUTE
 MIAMI-DADE JUNIOR COLLEGE

1967 SUMMER INSTITUTE

```

$$PLATE 20          BAR GRAPH USING TWO MACROS
CALL/REFAX,,XLEN=7,,YLEN=5,,XUN=0,,YUN=.5,,OR=PT/2.5,1.5
ALPHAP/ (.2,.2,.16,0), (0,-.2,0,0)
NOTE/.55,4.95,@TOTAL BACHELOR DEGREES AND DEGREES@,$
@IN SCIENCE AND ENGINEERING@
CALL/RECT,,X=.25,,Y=1.87,,ORX=.375,,OPT=0,,F=.1,,N=3,,LIT=@187@
CALL/RECT,,Y=1.85,,ORX=1.125,,LIT=@185@
CALL/RECT,,Y=1.26,,ORX=1.875,,LIT=@126@
CALL/RECT,,Y=1.36,,ORX=2.625,,LIT=@136@
CALL/RECT,,Y=2.72,,ORX=3.375,,LIT=@272@
CALL/RECT,,Y=4.34,,ORX=4.125,,LIT=@434@
CALL/RECT,,Y=3.32,,ORX=4.875,,LIT=@332@
CALL/RECT,,Y=2.93,,ORX=5.625,,LIT=@293@
CALL/RECT,,Y=3.11,,ORX=6.375,,LIT=@311@
CALL/RECT,,Y=.61,,ORX=6.625,,OPT=1,,N=2,,LIT=@61@
CALL/RECT,,Y=.53,,ORX=5.875,,LIT=@53@
CALL/RECT,,Y=.68,,ORX=5.125,,LIT=@68@
CALL/RECT,,Y=1.09,,ORX=4.375,,N=3,,LIT=@109@
CALL/RECT,,Y=.66,,ORX=3.625,,N=2,,LIT=@66@
CALL/RECT,,Y=.15,,ORX=2.875,,LIT=@15@
CALL/RECT,,Y=.3,,ORX=2.125,,LIT=@30@
CALL/RECT,,Y=.37,,ORX=1.375,,LIT=@37@
CALL/RECT,,Y=.36,,ORX=.625,,LIT=@36@
ALPHAP/ (.1,.1,.08,0), (0,0,0,0)
NOTE/-.3,0,@ 0@
NOTE/-.3,1,@100@
NOTE/-.3,2,@200@
NOTE/-.3,3,@300@
NOTE/-.3,4,@400@
NOTE/-.3,5,@500@
NOTE/.35,-.1,@1940@
NOTE/1.1,-.1,@1942@
NOTE/1.85,-.1,@1944@
NOTE/2.6,-.1,@1946@
NOTE/3.35,-.1,@1948@
NOTE/4.1,-.1,@1950@
NOTE/4.85,-.1,@1952@
NOTE/5.6,-.1,@1954@
NOTE/6.35,-.1,@1956@
ORIGIN/2.5,5.1
CALL/RECT,,Y=.2,,ORX=.625,,N=0
ALPHAP/ (.1,.1,.08,0), (0,-.1,0,0)
NOTE/.85,.1,@BACHELOR DEGREES IN SCIENCE@,$
@AND ENGINEERING, IN THOUSANDS@
ORIGIN/2.5,5.5
CALL/RECT,,OPT=0
NOTE/.85,.1,@TOTAL BACHELOR DEGREES, IN THOUSANDS@
FINI/

```

1967 SUMMER INSTITUTE

```
REFAX=MACRO/XLEN,YLEN,XUN,YUN
DEFPT/OR
XYZ=VIEW/
ORIGIN/OR
XNOTCH=0
YNOTCH=0
LN/DY,YLEN
LN/DY,-YLEN
LN/DX,XLEN
LN/DX,-XLEN
LOOPST/
IF(YUN)2,2,1
1) YNOTCH=YNOTCH+YUN
LN/0,YNOTCH,DX,YUN/5
IF(YNOTCH-YLEN)1,2,2
2) IF(XUN)4,4,3
3) XNOTCH=XNOTCH+XUN
LN/XNOTCH,0,DY,-XUN/5
IF(XNOTCH-XLEN)3,4,4
4) LOOPND
END/XYZ
DRAW/XYZ
TERMAC/
```

1967 SUMMER INSTITUTE

```
RECT=MACRO/ORX,X,Y,OPT,N,F
DEFLT/LIT
ABC=VIEW/
REFSYS/ORX-X/2,0
LN/DY,Y
LN/,DX,X
LN/DY,-Y
LN/DX,-X
END/ABC
DRAW/ABC
ALPHAP/(F,F,.8*F,0),(0,0,0,0)
LOOPST/
IF(N)9,9,0
0) NOTE/X/2-.8*F*(N-1)/2,Y+F,LIT
9) IF(OPT)4,4,1
1) IF(OPT-1)4,2,3
2) HATCHP/0,.05,0,0
HATCH/ABC
JUMPTO/4
3) IF(OPT-2) 4,5,6
5) HATCHP/45,.05,0,0
HATCH/ABC
JUMPTO/4
6) IF(OPT-3)4,7,4
7) HATCHP/90,.05,0,0
HATCH/ABC
4) LOOPND
REFSYS/NOMORE
TERMAC/
```

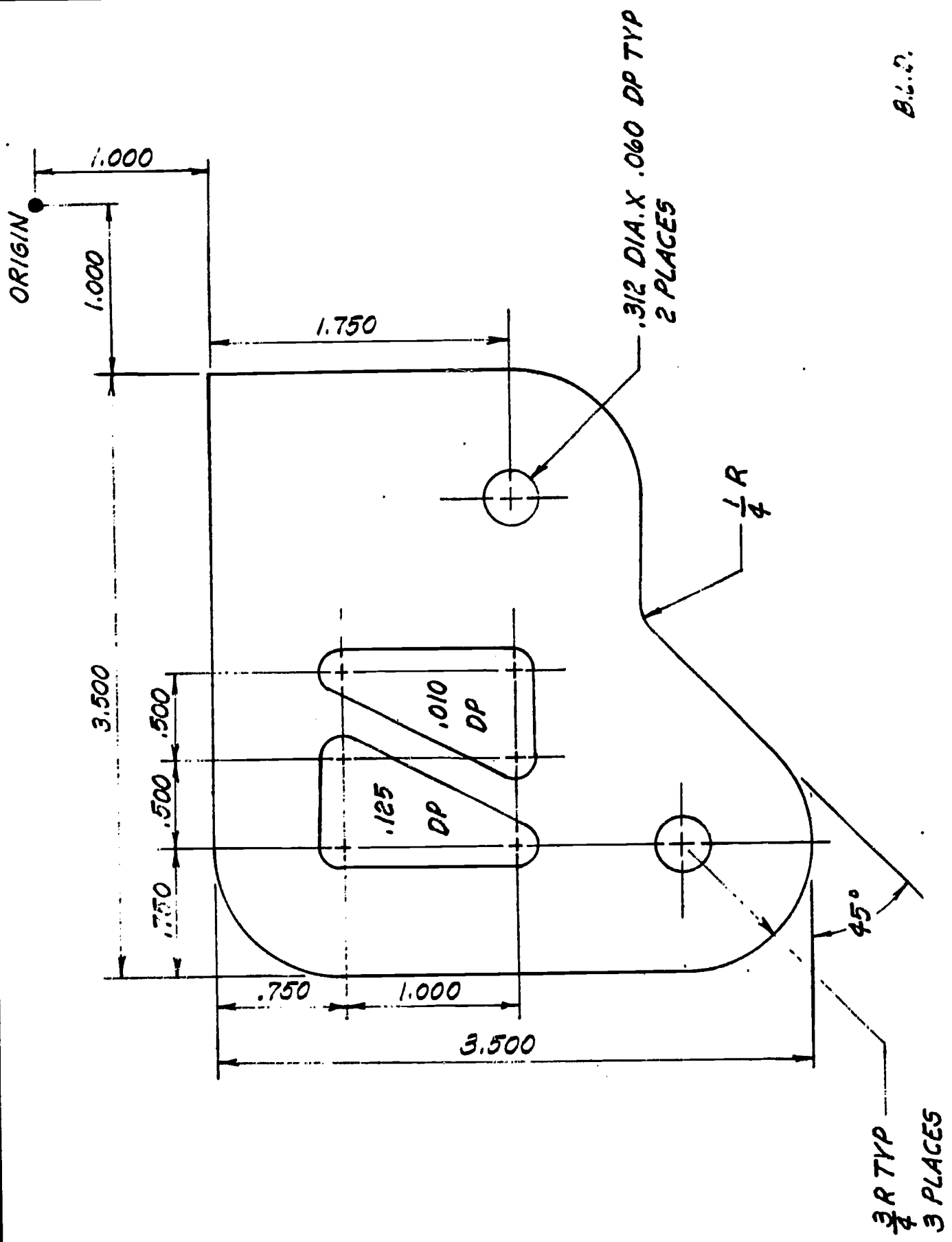

B.L.D.

SKETCH 21
1967 SUMMER INSTITUTE

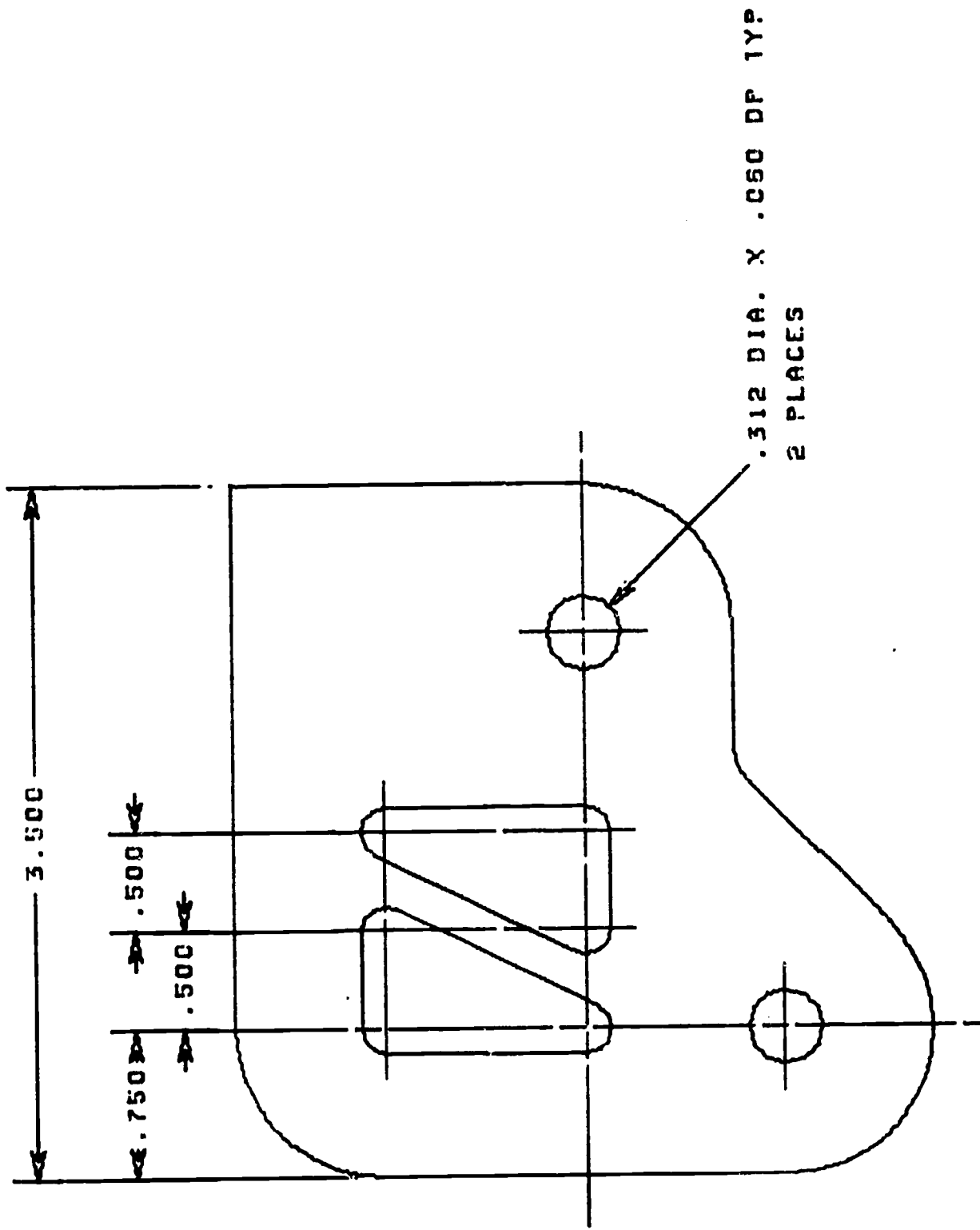

PLATE 21

1967 SUMMER INSTITUTE
MIAMI-DADE JUNIOR COLLEGE

*** 1967 SUMMER INSTITUTE

```

$$ PLATE 21          CONTINUOUS PATH MILLING
BOX      =          VIEW /
CALL/FRAME1,,X=10,,Y=6.5,,ORX=.5,,ORY=.5
          END /BOX
          DRAW /BOX
          ALPHAP/(.2,.2,0,-.2),(0,0,0,270)
          TITLE /1.5,2.5,@PLATE 21@
          ORIGIN/8.69,6.5

FRAME1   =          VIEW /
P17      =          PT /-4.5,-1.69
P18      =          PT /-3.75,-1
P19      =          PT /-3.25,-1.625
P20      =          PT /-2.75,-1.625
P0       =          PT /-1,-1
L3       =          LN /P0,DX,-3.5
          ARC / .75
          LN /DY,-2.75
          ARC /-3.75,-3.75,.75,180,135
P1       =          PT /PPP
          LN /P0,DY,-1.75
P4       =          PT /PPP
          ARC /-1.75,-2.75,.75,0,-90
P2       =          PT /PPP
L1       =CONSTR,LN /P2,DX,-1
L2       =CONSTR,LN /P1,ATANGL,45,LENGTH,2
P3       =          PT /INTOF,L1,L2
          LN /P1,P3
          ARC / .25
          LN /P3,P2
          END /FRAME1
          DRAW /FRAME1
          ORIGIN/8.69,6.5

CONCIR   =          VIEW /
C5       =CONSTR,CIRCLE/-3.75,-1.75,.125
C6       =CONSTR,CIRCLE/-3.75,-2.75,.125
C7       =CONSTR,CIRCLE/-3.25,-1.75,.125
C8       =CONSTR,CIRCLE/-3.25,-2.75,.125
C9       =CONSTR,CIRCLE/-2.75,-2.75,.125
C10      =CONSTR,CIRCLE/-2.75,-1.75,.125
P5       =          PT /-3.875,-2.25
P6       =          PT /-2.625,-2.25
          LN /P5,RIGHT,TANTO,C6
          ARC / .125
          LN /RIGHT,TANTO,C6,RIGHT,TANTO,C7
          ARC / .125
          LN /RIGHT,TANTO,C7,RIGHT,TANTO,C5
          ARC / .125
          LN /-3.875,-1.75,P5
          LN /P6,LEFT,TANTO,C9
          ARC / .125
          LN /LEFT,TANTO,C9,LEFT,TANTO,C8
          ARC / .125

```

```

LN      /LEFT,TANTO,C8,LEFT,TANTO,C10
ARC     /.125
LN      /-2.625,-1.75,P6
CIRCLE /-1.75,-2.75,.187
CIRCLE /-3.75,-3.75,.187
P11     =      PT      /-4.75,-2.75
          CTRLN ,LN     /P11,DX,4
P12     =      PT      /-4.062,-3.75
          CTRLN ,LN     /P12,DX,.624
P13     =      PT      /-4,-1.75
          CTRLN ,LN     /P13,DX,1.5
P14     =      PT      /-3.75,-.75
          CTRLN ,LN     /P14,DY,-4
P15     =      PT      /-2.75,-1.5
          CTRLN ,LN     /P15,DY,-1.5
P16     =      PT      /-1.75,-2.438
          CTRLN ,LN     /P16,DY,-.624
          CTRLN,LN     /-3.25,-1.5,DY,-1.5
END      /CONCIR
DRAW     /CONCIR
DIMST   /YLARGE,XCOMP,L3,.5
DIMP    /.5,.1,1,1
MASK    /@PD3TN@
DIM      /P17,P18
DIMST   /YLARGE,XCOMP,L3,.5
DIMP    /.5,.1,2,2
DIM      /P19,P20
DIMST   /YLARGE,XCOMP,L3,.25
DIMNN   /P18,P19
DIMST   /YLARGE,XCOMP,L3,1
DIMP    /.5,.1,1,1
DIM      /L3
ALPHAP  /(.1,.1,.1,0),(0,-.2,0,0)
NOTE    /-1.75+(SQRT(2)/2)*.187,-2.75-(SQRT(2)/2)*.187,
.75,-.75,@.312 DIA. X .060 DP TYP@,@2 PLACES@
FINI    /

```

NUMERICAL CONTROL

Coordinate System

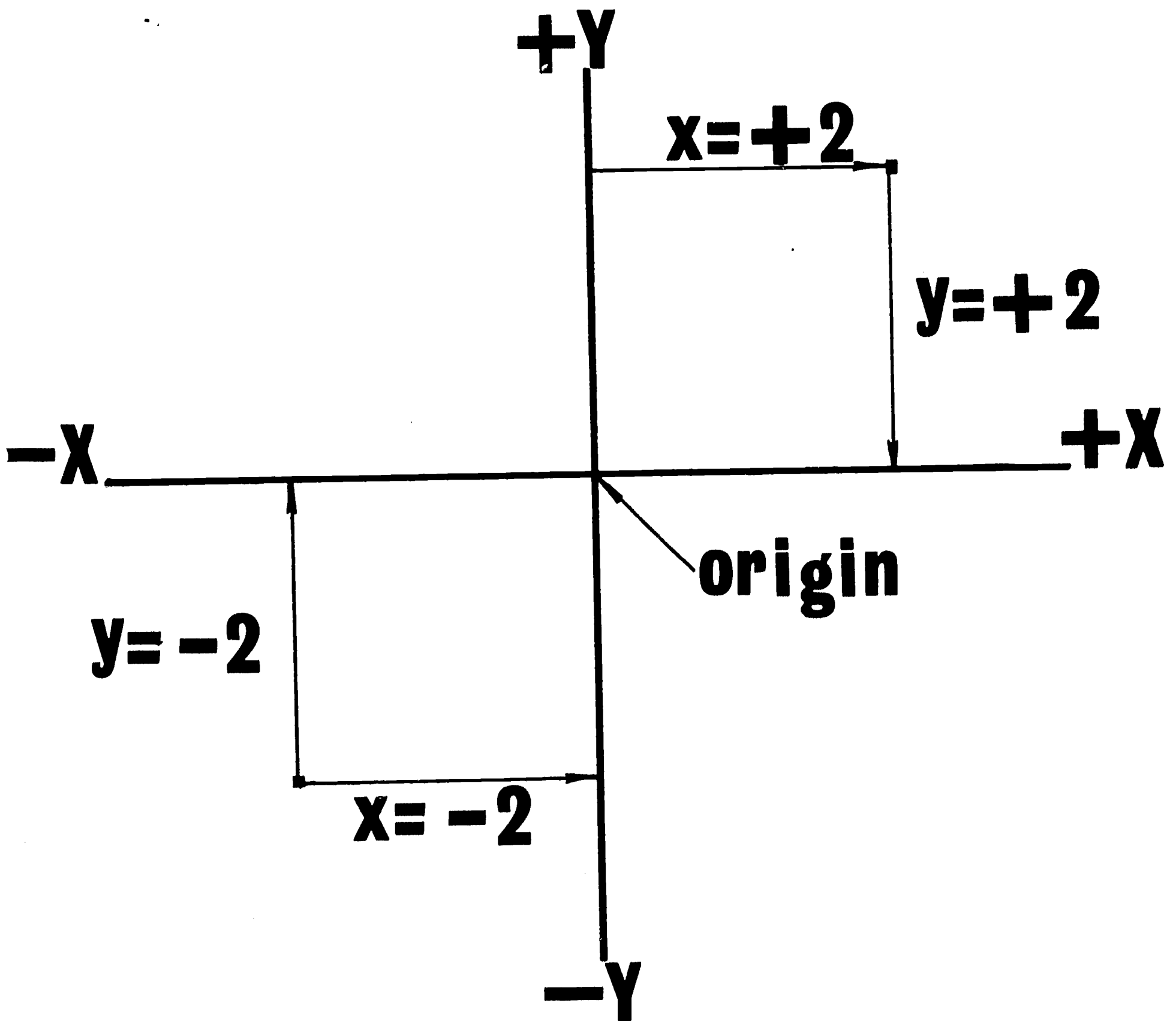

Coordinates of N.C. Machines

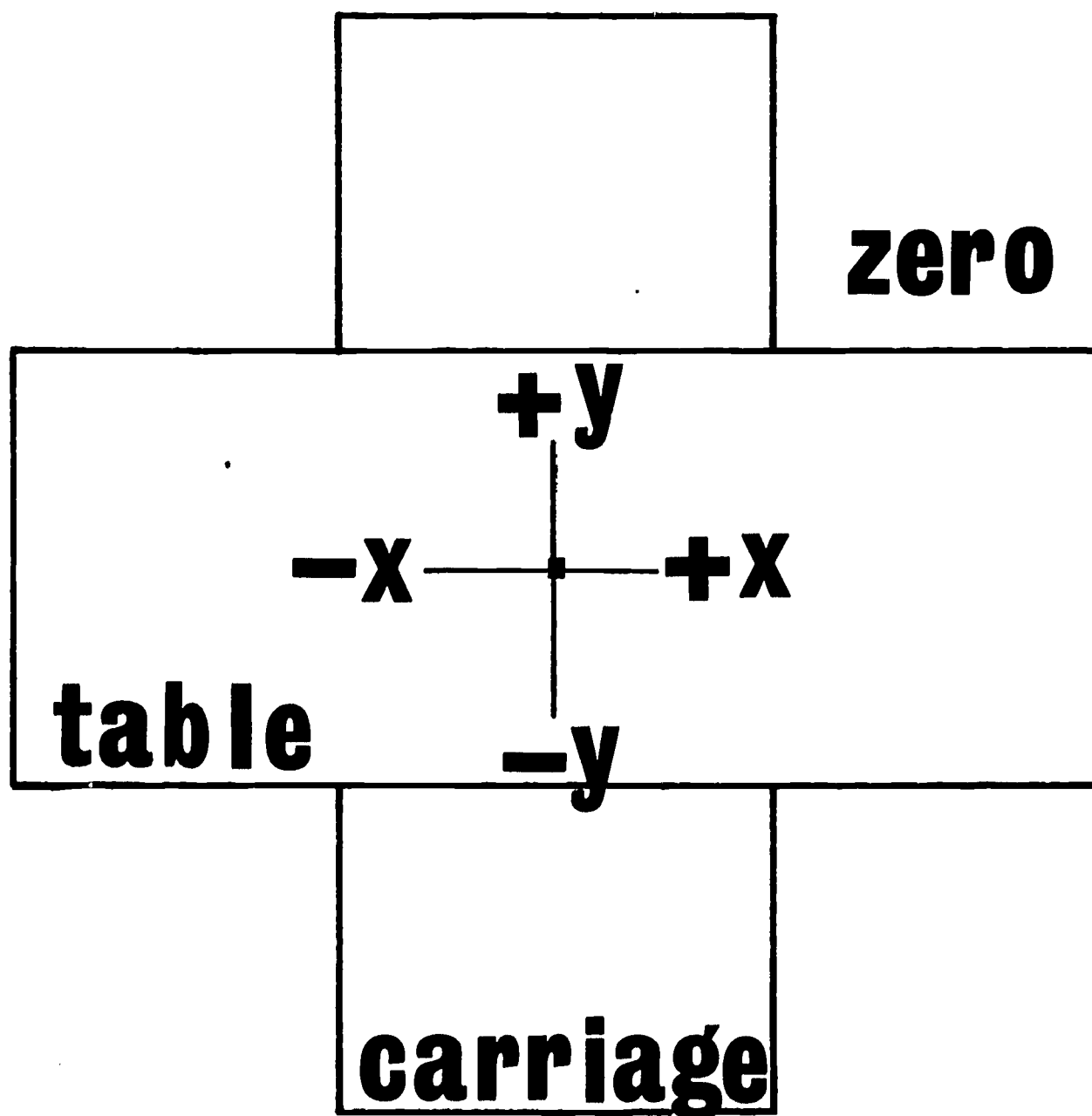

Conventional Drawing

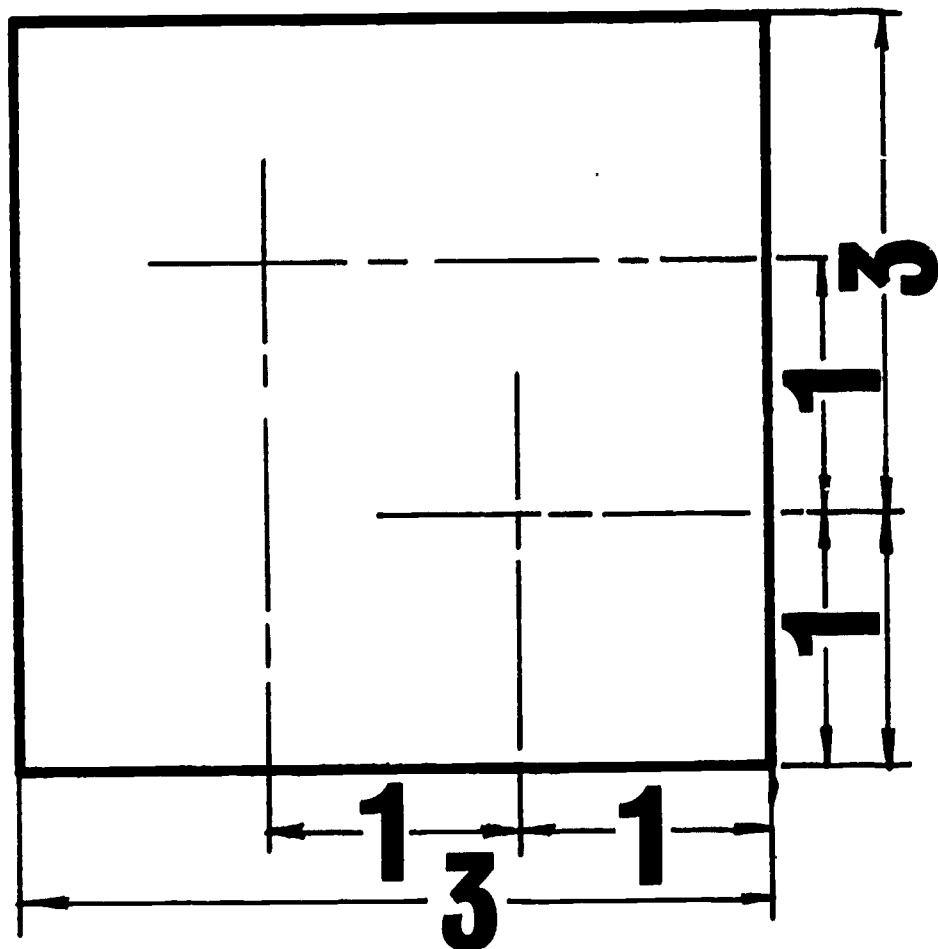

N.C. Dimensioning

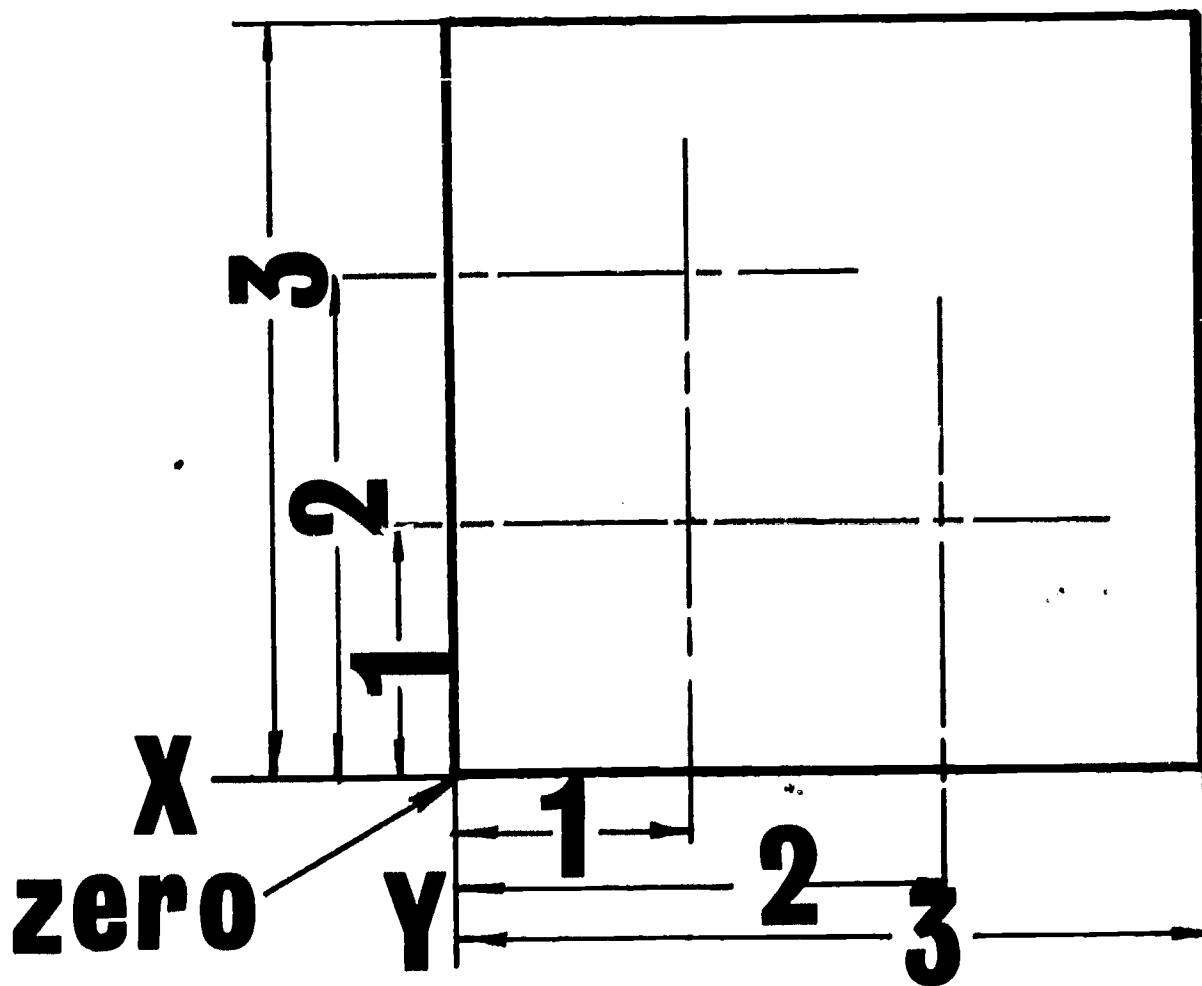

N.C. Code

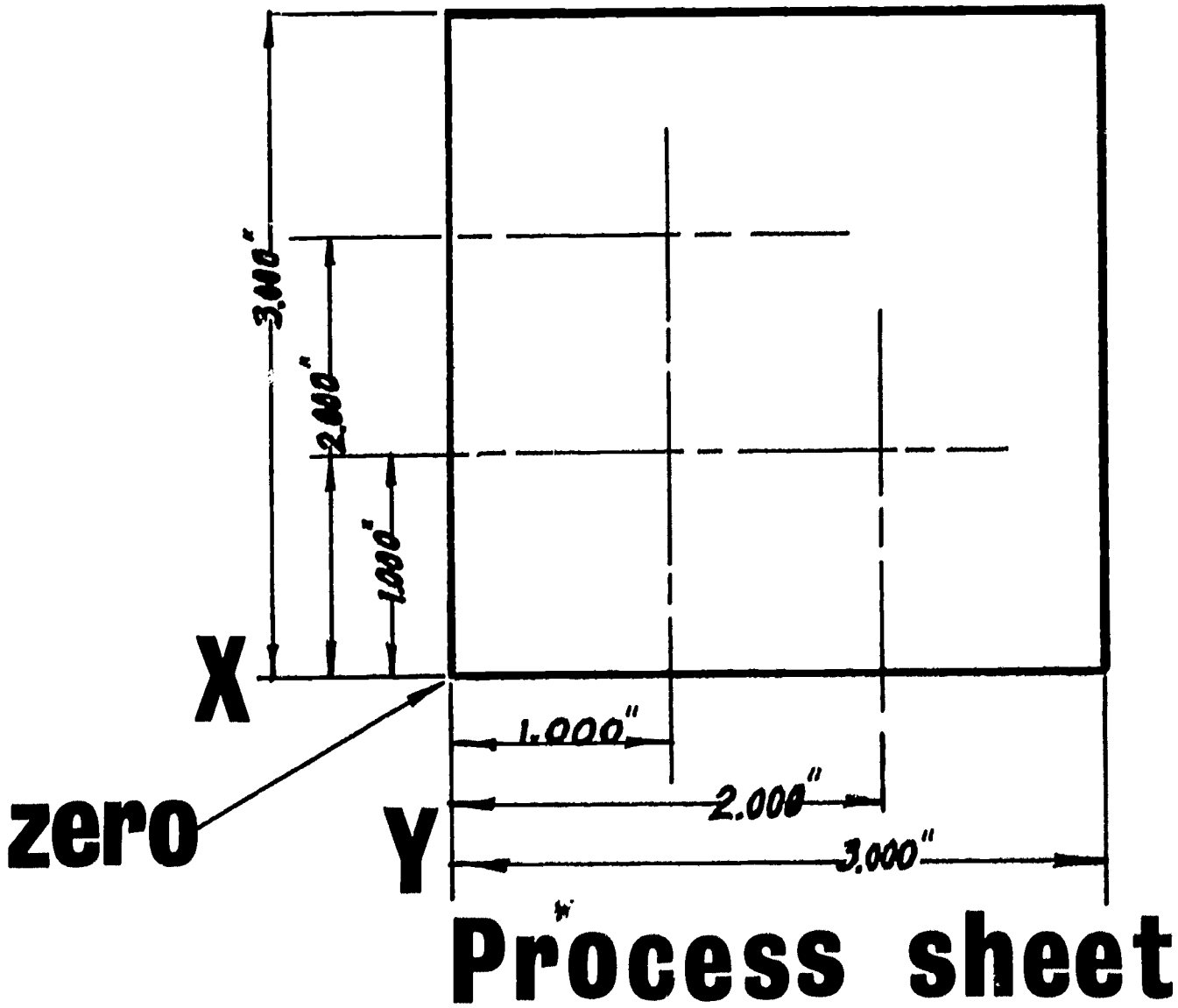
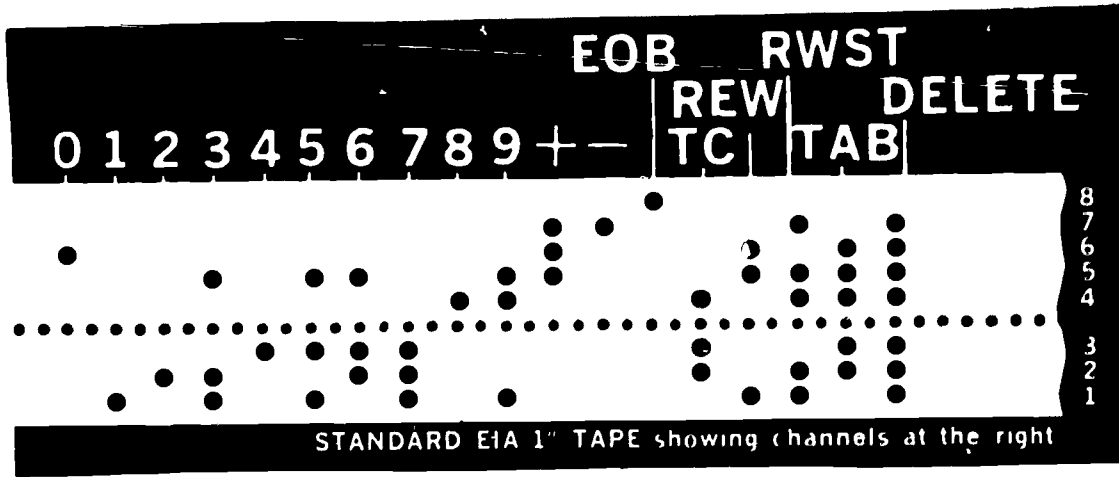

INC. NO.	SEQ. NO.	TAB OR EOB	+ OR -	"X" COORDINATE	TAB OR EOB	+ OR -	"Y" COORDINATE	TAB OR EOB	INSTRUCTIONS	EOB
	000	T		0	T		0	E	Set up Zero from lower left corner	
NS	001	T	+	1.000	T	+	2.000	E	Bore hole # 1	

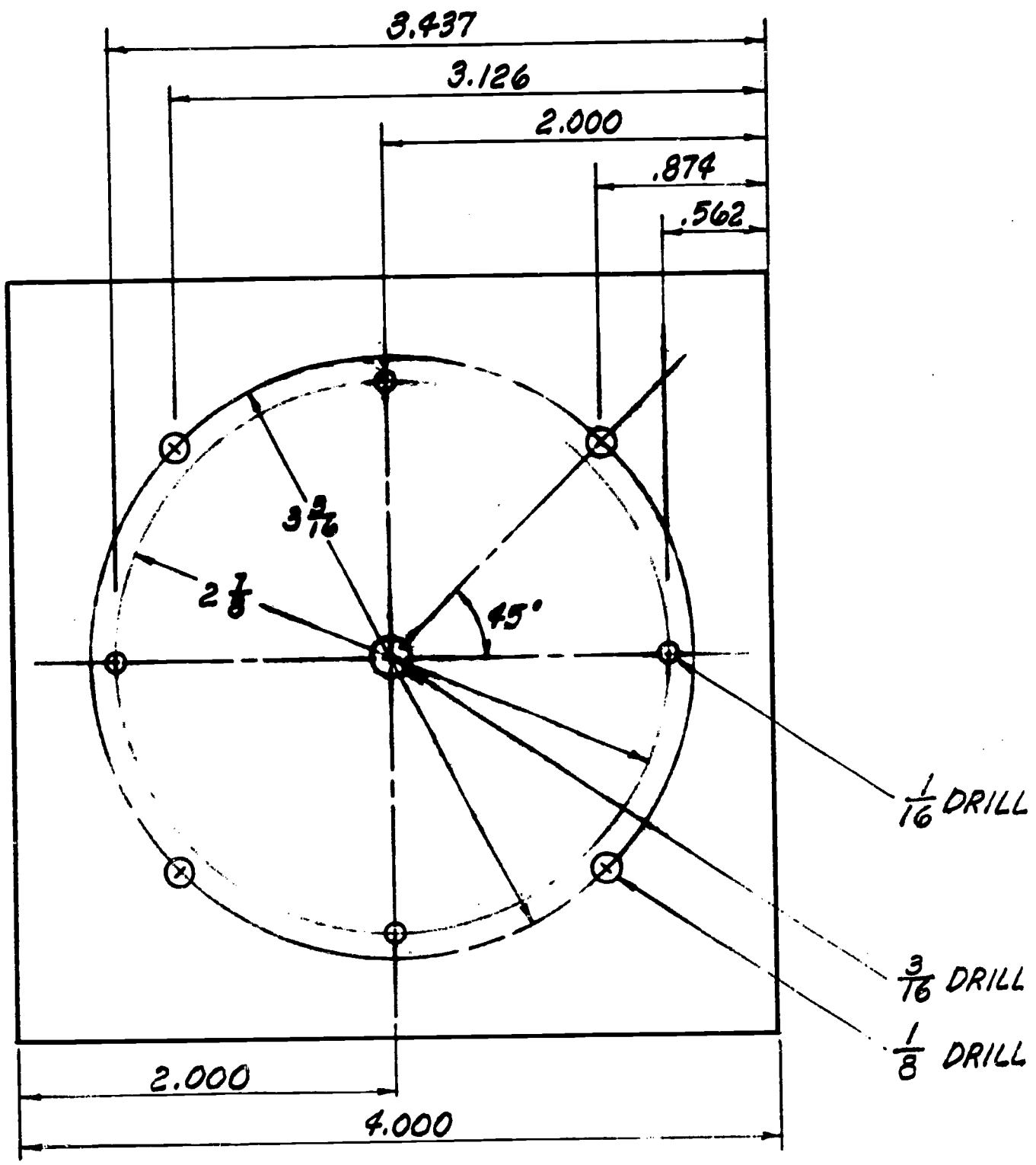

B.L.F.

AUTOSPOT SKETCH

MIAMI-DADE JUNIOR COLLEGE

AUTOSPOT II PRELIST

PAGE 1

1 REMARK/FLANGE PLATE \$ MIAMI-DADE JUNIOR COLLEGE 1967 SUMMER INSTITUTE
2 REMARK/TP(4.575,-5.077) \$ MAXIMUM TABLE POSITION REFERRED TO SET UP POINT
3 DASH A (0.575,-1.077) \$ DATUM SURFACE OR HOLE (REFERENCE SYSTEM) ID - A
4 START \$ GENERATES A SEQUENCE NO. AND A REWIND STOP CODE
5 DRILL,0625/DAA,AT(2.0,-2.0)R(1.4375)SA(00.0)IA(90.0)NH(4)/DP(0.5)FR(5.0)\$
6 DRILL,1250/DAA,AT(2.0,-2.0)R(1.5938)SA(45.0)IA(90.0)NH(4)/DP(0.5)FR(5.0)\$
7 DRILL,1875/DAA (2.0,-2.0) \$ /DP(0.5)FR(5.0)\$
8 FINI \$ GENERATES A TOOL CHANGE AND AN AUTO REWIND CODE

END PREPROCESSOR
SPECIFICATION SECTION

MACHINE SECTION
END PHASE 1
PHASE2 SECTION

END PHASE2

AUTOSPOT-TAPE-O-MATIC POST PROCESSOR

PART NUMBER-	NAME		
FLANGE PLATE	\$ MIAMI-DADE JUNIO		
TP(4.575,-5.077)	\$ MAXIMUM TABLE PO		
001X-00575X+01077		SET POINT	0001
X002	START		0002
	FEED RATE 05.0 IN/MIN		
	DRILL CHANGE TOOL,TOOL NO. 0625		
004X+03437X-02000		DEPTH 0.5000	0004
005X+02000X-00562			0005
006X+00562X-02000			0006
007X+02000X-03437			0007
	FEED RATE 05.0 IN/MIN		
X008	DRILL CHANGE TOOL,TOOL NO. 1250		
009X+03126X-00873		DEPTH 0.5000	0009
010X+00873X-00873			0010
011X+00873X-03126			0011
012X+03126X-03126			0012
	FEED RATE 05.0 IN/MIN		
X013	DRILL CHANGE TOOL,TOOL NO. 1875		
014X+02000X-02000		DEPTH 0.5000	0014
X/015	STOP		0015

FINI POST PROCESSOR

TOTAL PRODUCTION TIME 001.2

001Ж000575Ж001077‡

002‡

004Ж003437Ж002000‡

005Ж002000Ж000562‡

006Ж000562Ж002000‡

007Ж002000Ж003437‡

Ж008‡

009Ж003126Ж000873‡

010Ж000873Ж000873‡

011Ж000873Ж003126‡

012Ж003126Ж003126‡

Ж013‡

014Ж002000Ж002000‡

Ж1015‡

TAPE OUTPUT FROM AUTOSPOT II ACCORDING TO 1620 CHARACTERS

001	-00575	&01077
%002		
004	&03437	-02000
005	&02000	-00562
006	&00562	-02000
007	&02000	-03437
008		
009	&03126	-00873
010	&00873	-00873
011	&00873	-03126
012	&03126	-03126
013		
014	&02000	-02000
/015		

FRIDEN FLEXOWRITER INTERPRETATION OF TAPE
 OUTPUT FROM AUTOSPOT II OUTPUT

COGO

1967 SUMMER INSTITUTE
MIAMI-DADE JUNIOR COLLEGE
COGO

Exercise 1

Write a COGO program using Sketch 21 to determine the following:

1. Find the coordinates, relative to the origin, of the centers of the arcs and circles,
2. Plot the centers found in '1'.

Exercise 2

Write a COGO program using the COGO Sketch to determine the following:

1. The distance from the nose of the median to the intersection of the center lines of Road A and Street 1,
2. The distance and offset measured along and from the center line of Road A of the PC, PRC and PT of the median,
3. The center coordinates of the reverse curve and the area of the median from the nose to the PT,
4. The coordinates of:
 - A. PC and PT of all R/W arcs,
 - B. The center of all R/W arcs.

Exercise 3

Write a COGO program using the COGO Sketch and any data from Exercise 2 to determine the following:

1. The distance from the NW corner of the traffic island in Street 1 to the intersection of the center lines of Street 1 and Road A,
2. Center coordinates of the arc of the traffic island,
3. The tangent and deflection angle of the curve that forms the S. R/N line of Road A,
4. Assume the P.C. of the median is at Station 9 + 00.00; find the Station at the PRC and PT of the median.

Exercise 4

Write a COGO program to plot the COGO sketch.

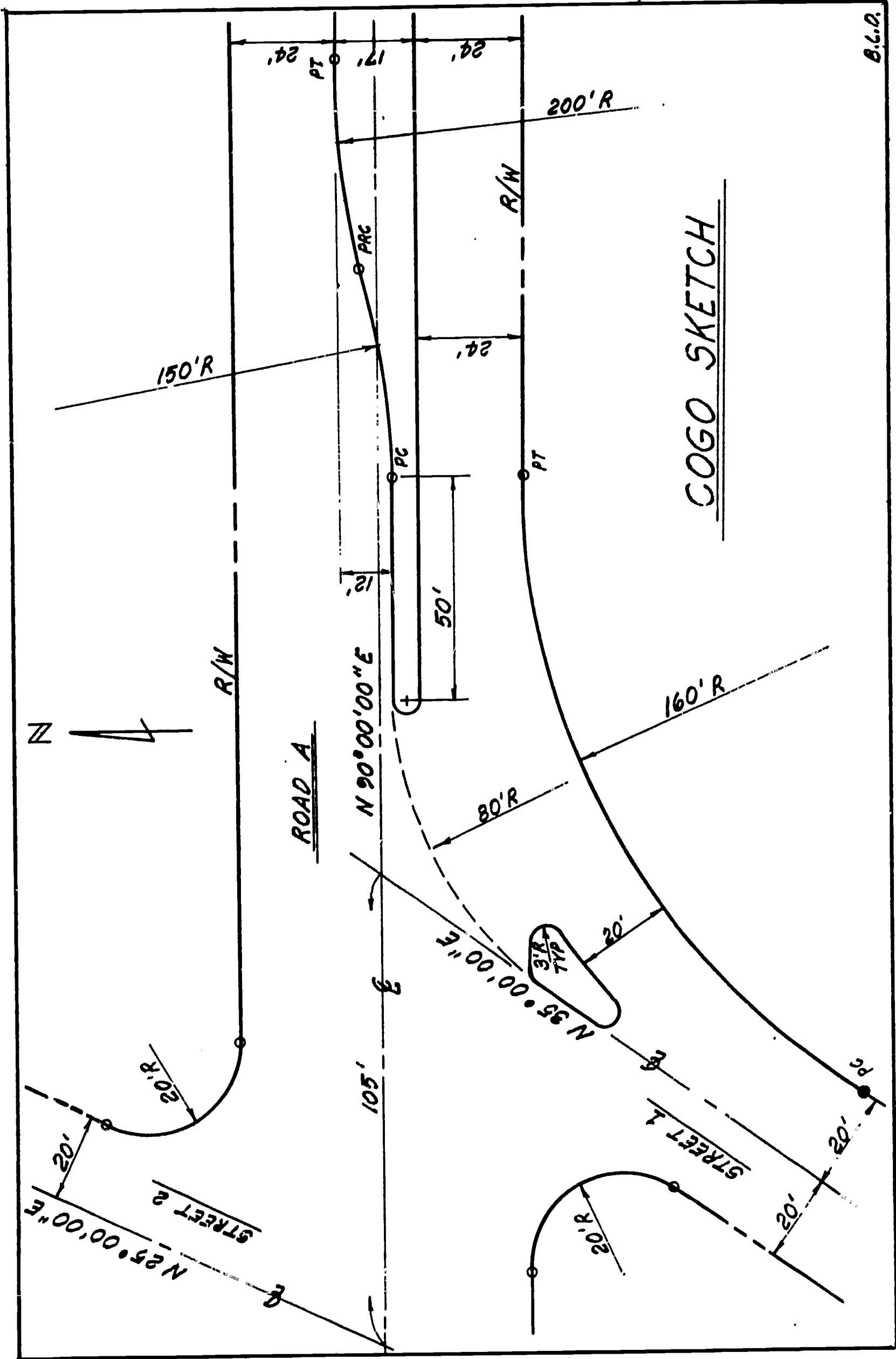

B.L.O.

COGO SKETCH